

ZONE	REV	ECN NUMBER	DESCRIPTION	BY	DATE	APPROVED
	F	BWAG-18101704	UPDATED NOTE 1. ADDED NOTE 12. REVISED BASE THICKNESS TOLERANCE 0.10 WAS 0.13. ADDED SURFACE GROUND PLANE.	HCL-UD	10/29/2018	B.WANG
SHT1, C3	G	HHUG-20010801	ADDED PLATING OPTION 'P' TO P/N TREE	HCL-SG	01/23/2020	H.HUANG
SHT9	H	HHUG-20090906	ADDED SE MODULE PCB DETAILS.	HCL-SH	10/06/2020	H.HUANG

XCede HD2 BACKPLANE MODULE MALE STANDARD LOAD

9 7 2 - 4 X 1 C - X 0 X

4 PAIR

6-POSITION

LETTER	PLATING
D	NI SULFAMATE, STANDARD GOLD, LEADFREE
E	NI SULFAMATE, HIGH GOLD, LEADFREE
H	NANO NI, STANDARD GOLD, LEADFREE
J	NANO NI, HIGH GOLD, LEADFREE
P	Pd-NI, STANDARD GOLD, LEADFREE

NOTE: ONLY THREE MOST RECENT RELEASED REVISIONS DISPLAYED.

NUMBER	SIGNAL & GROUND WIPE LENGTH, COMPLIANT PIN SIZE
G	2 mm WIPE SIGNAL, 3 mm WIPE GND, Ø.0157" DRILL
J	2 mm WIPE SIGNAL, 2 mm WIPE GND, Ø.0157" DRILL

NUMBER	WALL THICKNESS / SHIELD OPTION
1	THICK WALL, W/ EXTRA GROUND

	LETTER									
LEFT POLARIZING GUIDANCE (SEE SHEET 6)	J (NO KEY)	A	B	C	D	E	F	G	H	
RIGHT POLARIZING GUIDANCE (SEE SHEET 7)	Y (NO KEY)	P	Q	R	S	T	U	V	W	
OPEN (SEE SHEET 2)	O (ZERO)									
LEFT WALL (SEE SHEET 3)	L									
RIGHT WALL (SEE SHEET 4)	M									
TWO WALL (SEE SHEET 5)	1									

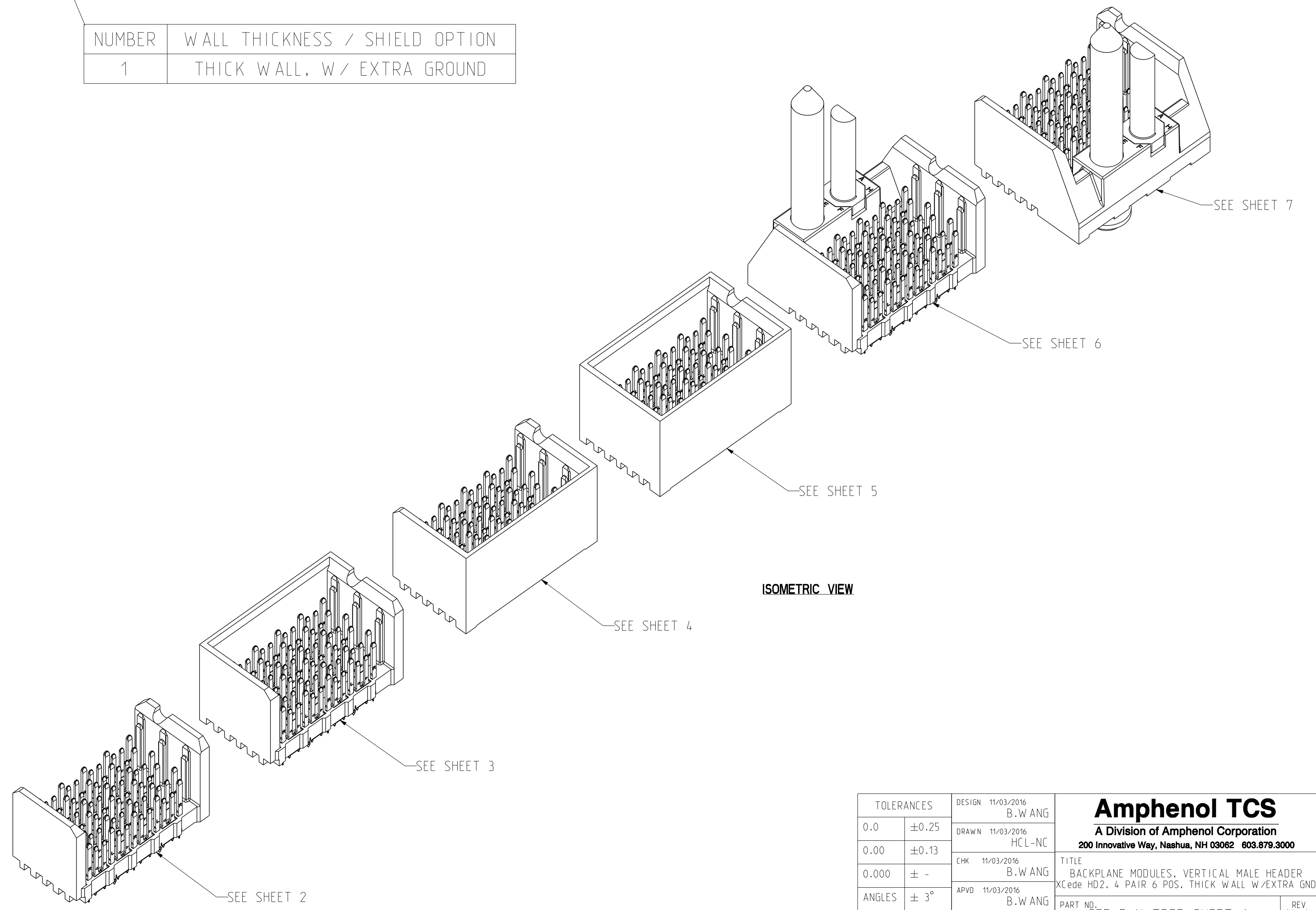

ISOMETRIC VIEW

- NOTES:
- REFER TO TB-2343 FOR XCede HD2 PRODUCT SPECIFICATIONS.
 - NOTCH DESIGNATES "ROW A" SIDE OF SHROUD. NOTCH FEATURE ON OPPOSITE SIDE FROM PART MARKING.
 - SEE TB-2325 FOR PART MARKING REQUIREMENTS.
 - PLATING THICKNESS OF SIGNAL CONTACT AND GROUND CONTACT IS DETERMINED BY PLATING CODE.
 - REPAIR PROCEDURE FOR MODULE, SEE TB-2245.
 - SEE TB-2237 (XCede HD2 ROUTING GUIDELINES) FOR BOARD SPECIFIC DETAILS ON ROUTING, PLATING THICKNESS, SECONDARY DIAMETERS, PAD, ANTIPAD LOCATIONS, BACK DRILLING AND SHADOW VIAS.
 - SEE DOC C-190-0009-000 FOR TOOLING KEEPOUT ZONES.
 - BACKPLANE DATUM REFERENCE.
 - OPTIONAL HOLE/MOUNTING SCREW LOCATION FOR GROUNDED PIN OR ADDITIONAL GUIDE PIN SUPPORT. SEE DRAWING C-914-4010-000 FOR OPTIONAL HOLE DETAILS. ONLY APPLIES FOR MACHINED GUIDE PIN APPLICATIONS.
 - SHADOW VIAS (GND VIA'S) DO NOT RECEIVE COMPLIANT PINS. THEY ARE ADDED FOR IMPROVED SIGNAL INTEGRITY PERFORMANCE AND CAN CHANGE IN SIZE AND LOCATION BASED UPON THE SPECIFIC DESIGN DETAILS.
 - SURFACE GROUND PLANE EQUAL TO COMPONENT OUTLINE REQUIRED, SURFACE GROUND PLANE TO BE FREE FROM SOLDERMASK.
 - ALL PLASTIC MATERIAL IS UL 94V-0 FLAMMABLE.

TOLERANCES	DESIGN	11/03/2016	B.WANG	Amphenol TCS A Division of Amphenol Corporation 200 Innovative Way, Nashua, NH 03062 603.879.3000	
0.0	±0.25	DRAWN	11/03/2016	HCL-NC	TITLE BACKPLANE MODULES, VERTICAL MALE HEADER XCede HD2, 4 PAIR 6 POS, THICK WALL W/EXTRA GND
0.00	±0.13	CHK	11/03/2016	B.WANG	
0.000	± -	APVD	11/03/2016	B.WANG	PART NO. SEE P/N TREE SHEET 1
ANGLES	± 3°	UNLESS OTHERWISE SPECIFIED DIMENSIONS ARE IN MM. DECIMAL MARKER IS A PERIOD.			REV N/A
DRAWING NO. C-972-401C-500					REV H
ASSEM C972-401C-500_XG-HD2					0.2
DRAWING C972-401C-500_XG-HD2					0.16
SIZE	D	SCALE	1/1	SHEET 1 OF 9	

INTERPRET PER ASME Y14.5M
CODE IDENT 314.13

CUSTOMER USE
DRAWING

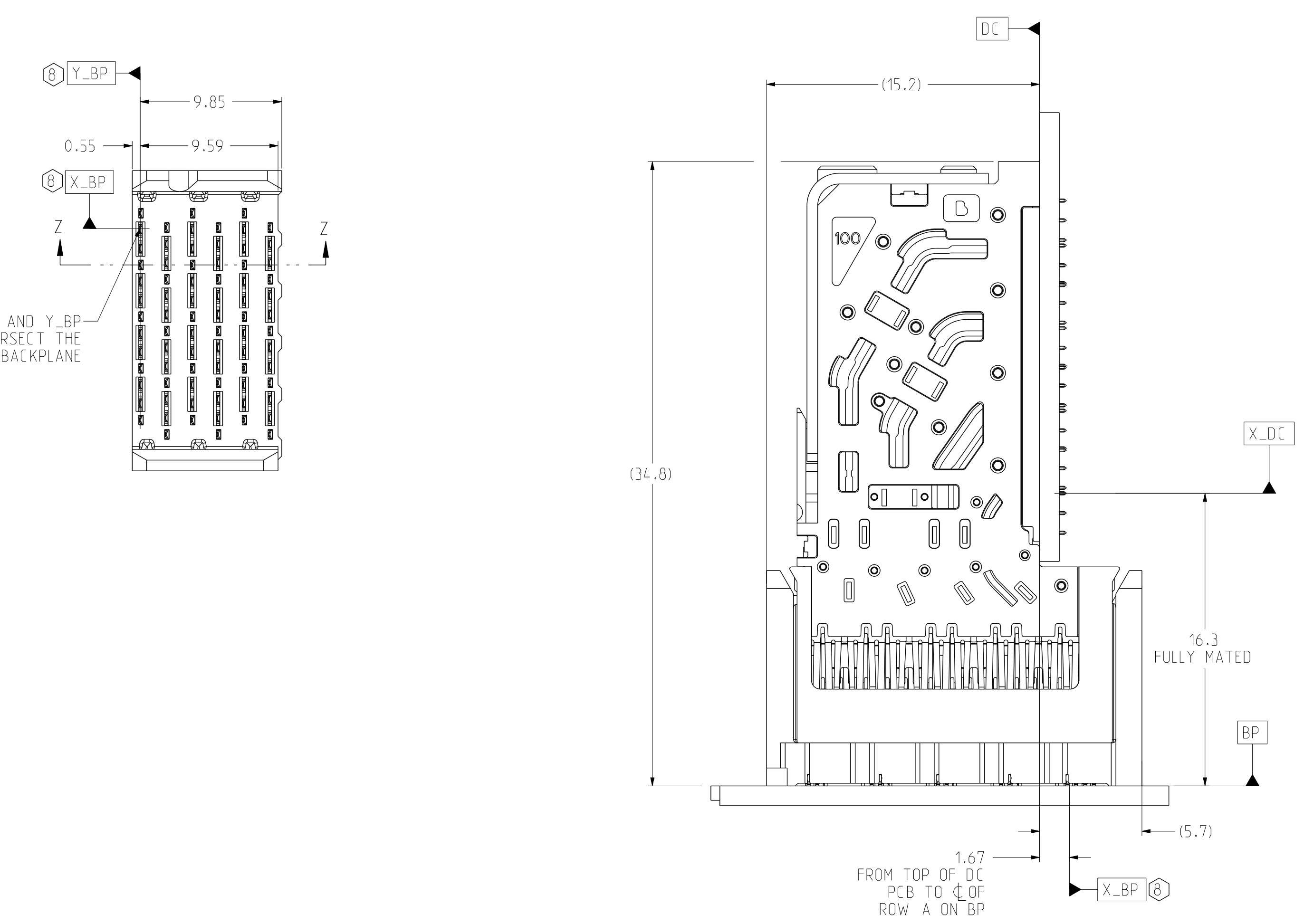

DATUMS X_BP AND Y_BP INTERSECT THE SIGNAL A1 VIA ON BACKPLANE

CONNECTOR REFERENCE
SCALE 5/1

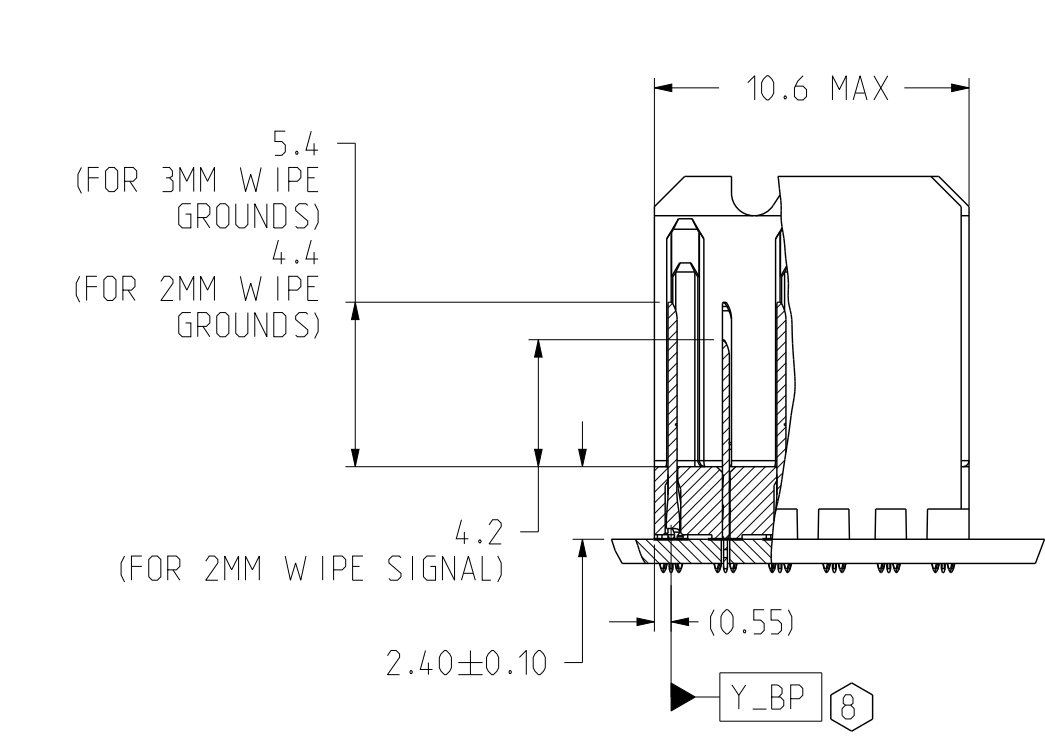

SECTION Z-Z

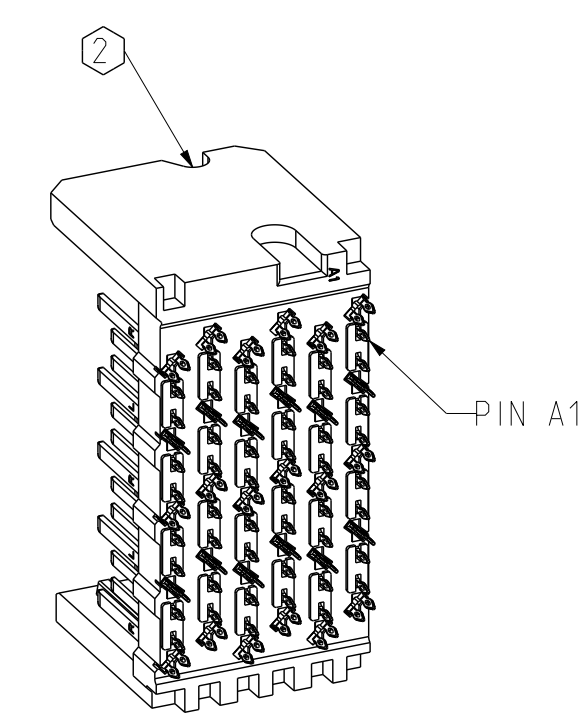
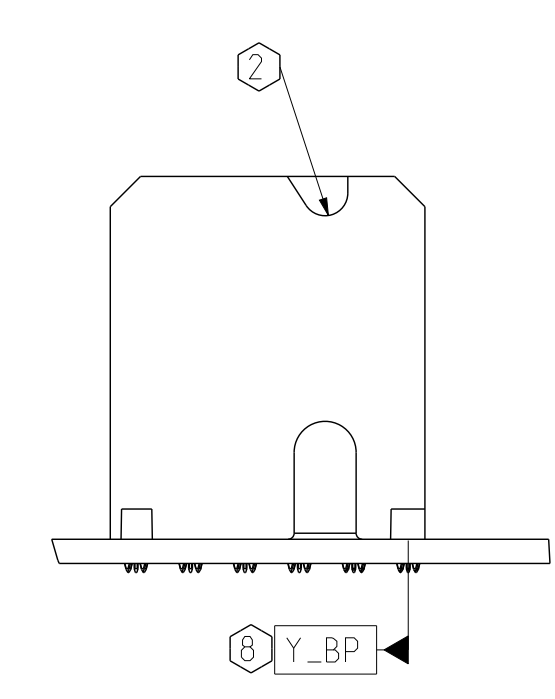
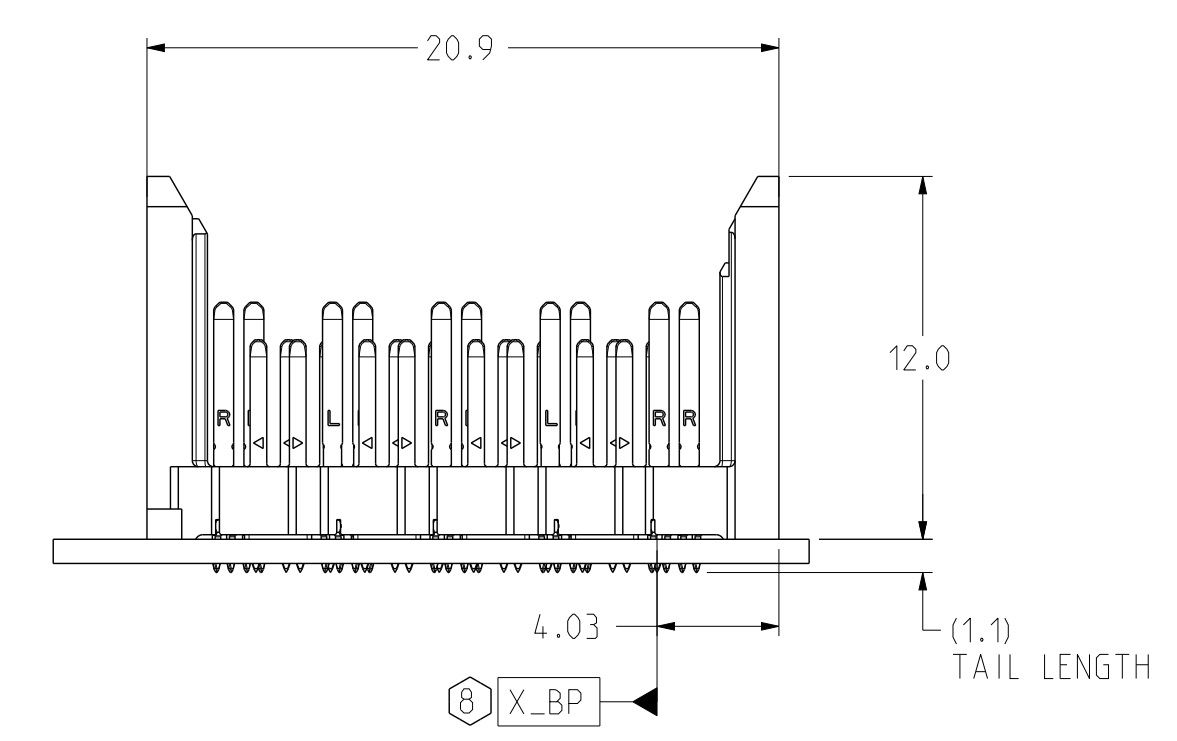

ISOMETRIC VIEW
SCALE 3/1

OPEN BACKPLANE MODULE DIMENSION

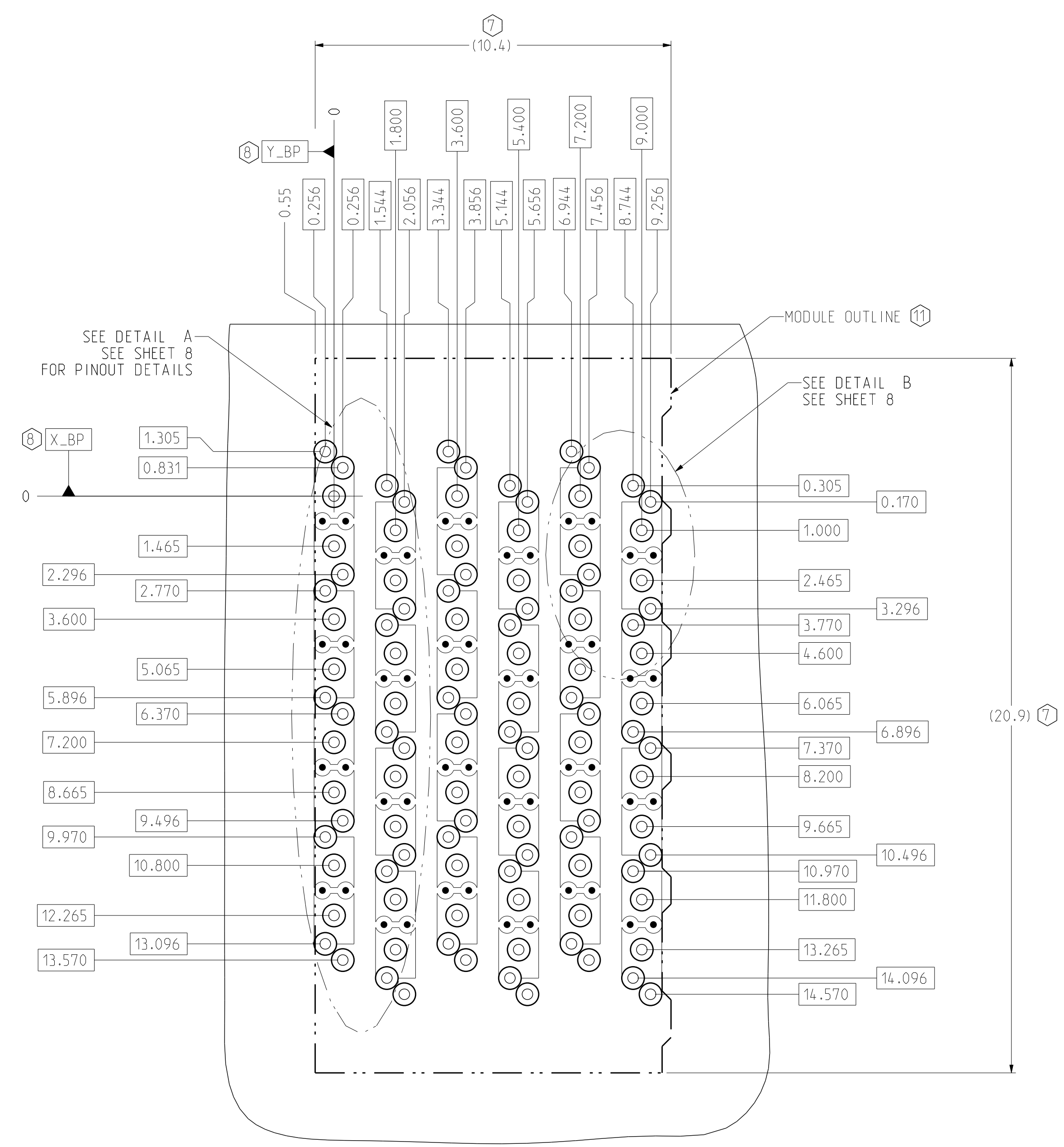

BP HOLE PATTERN
COMPONENT SIDE
SCALE 10/1

TOLERANCES	DESIGN 11/03/2016 B.W ANG	Amphenol TCS A Division of Amphenol Corporation 200 Innovative Way, Nashua, NH 03082 603.879.3000 TITLE BACKPLANE MODULES, VERTICAL MALE HEADER XCode HD2, 4 PAIR 6 POS, THICK WALL W/EXTRA GND PART NO. SEE P/N TREE SHEET 1 DRAWING NO. C-972-401C-500 ASSEM C972-401C-500_XG-HD2 DRAWING C972-401C-500_XG-HD2 SIZE D SCALE 1/1 SHEET 2 OF 9
0.0 ±0.25	DRAWN 11/03/2016 HCL-NC	
0.00 ±0.13	CHK 11/03/2016 B.W ANG	
0.000 ± -	APVD 11/03/2016 B.W ANG	
ANGLES ± 3°	UNLESS OTHERWISE SPECIFIED DIMENSIONS ARE IN MM. DECIMAL MARKER IS A PERIOD.	REV N/A REV H 0.2 0.16

INTERPRET PER ASME Y14.5M
CODE IDENT 31413

CUSTOMER USE
DRAWING

ZONE	REV	ECN NUMBER	DESCRIPTION	BY	DATE	APPROVED
			SEE SHEET 1			

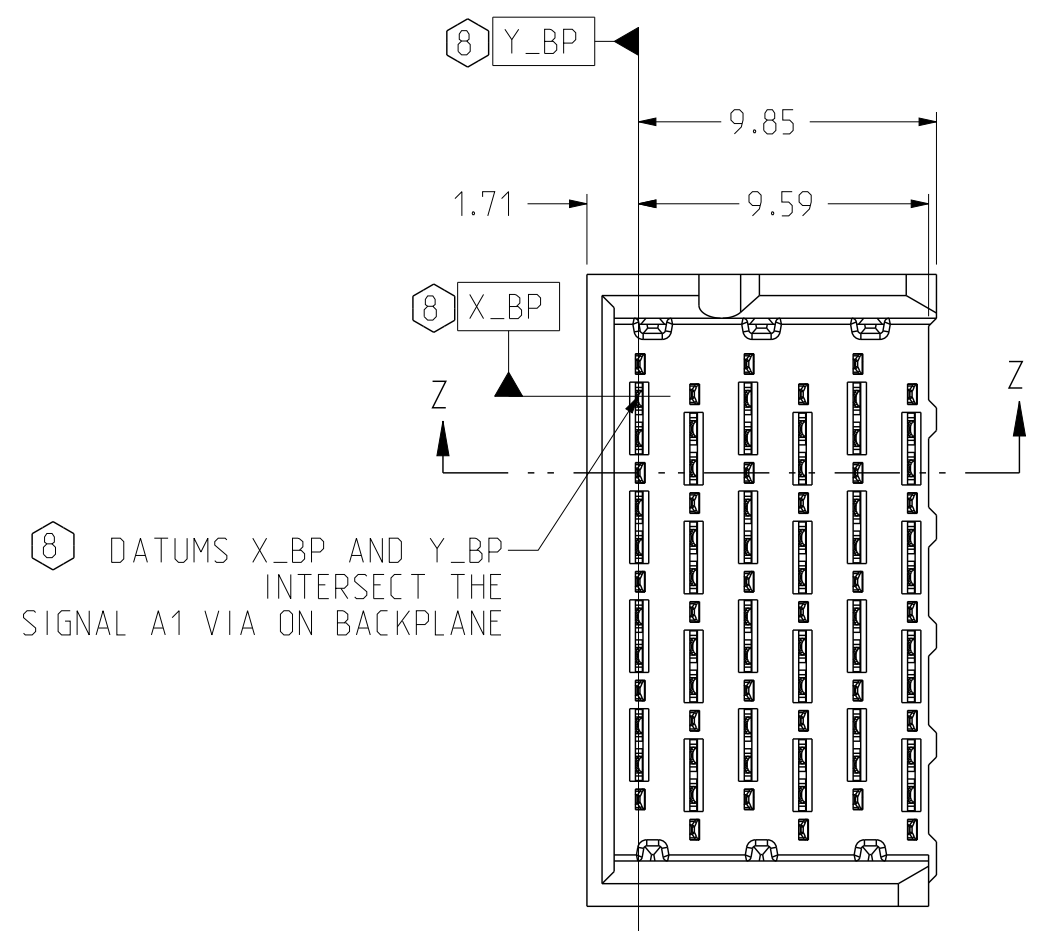

DATUMS X_BP AND Y_BP INTERSECT THE SIGNAL A1 VIA ON BACKPLANE

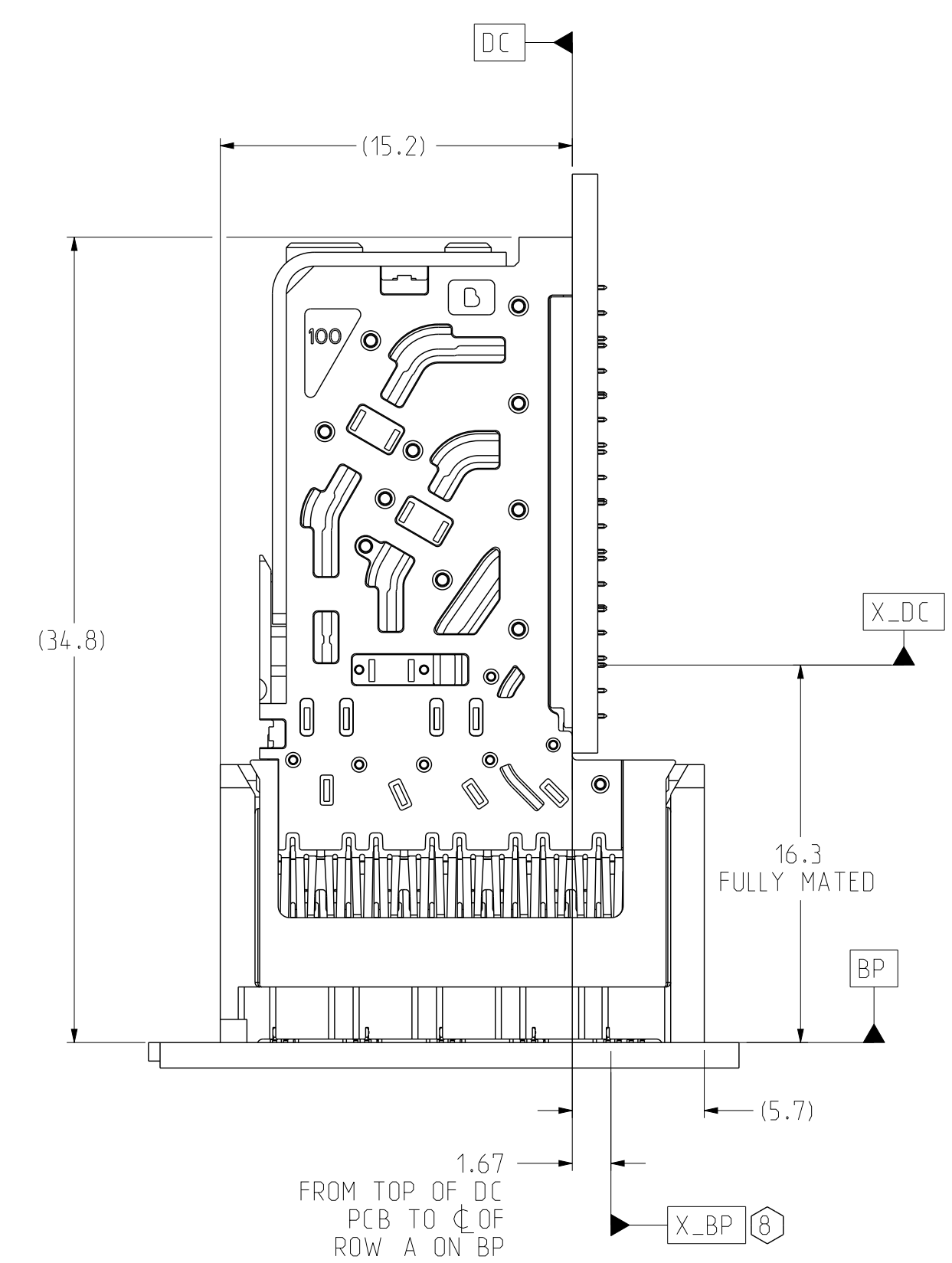

1.67 FROM TOP OF DC PCB TO ϕ OF ROW A ON BP

CONNECTOR REFERENCE SCALE 4/1

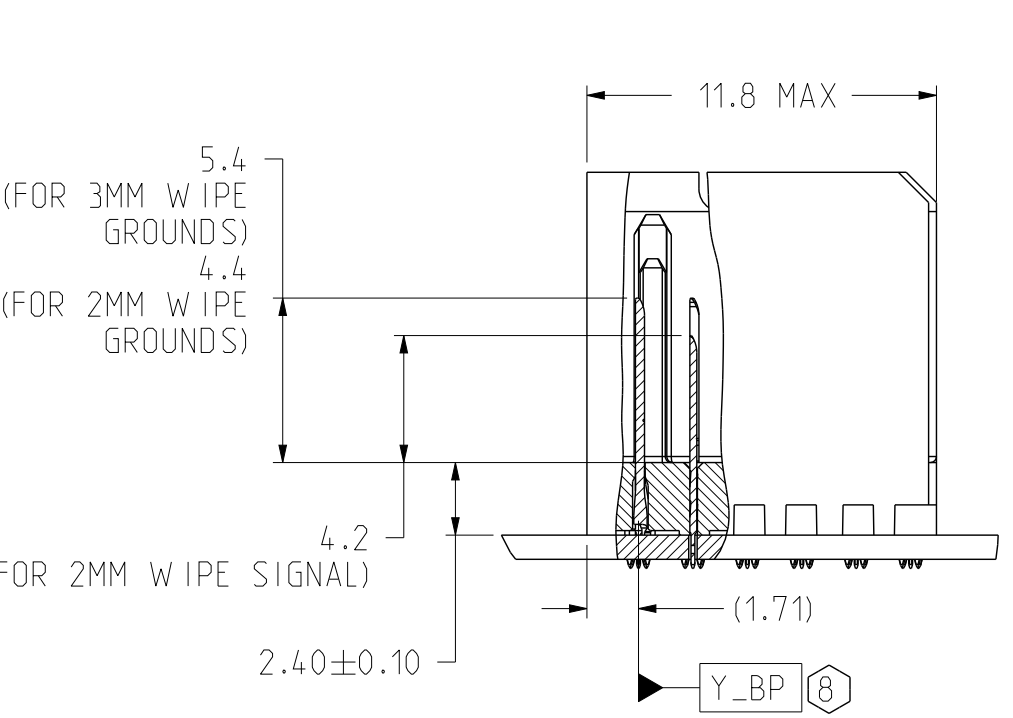

SECTION Z-Z

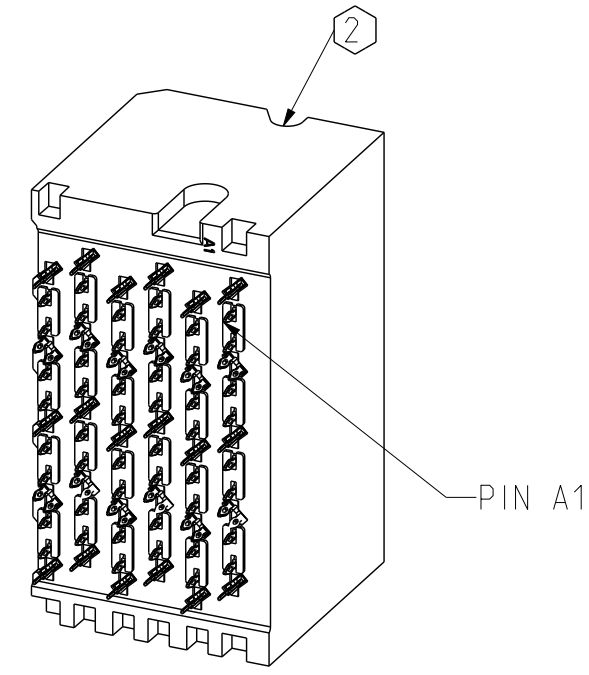
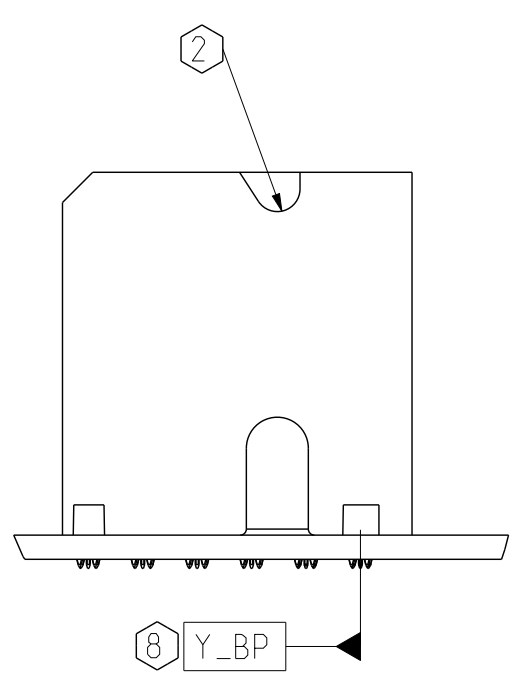
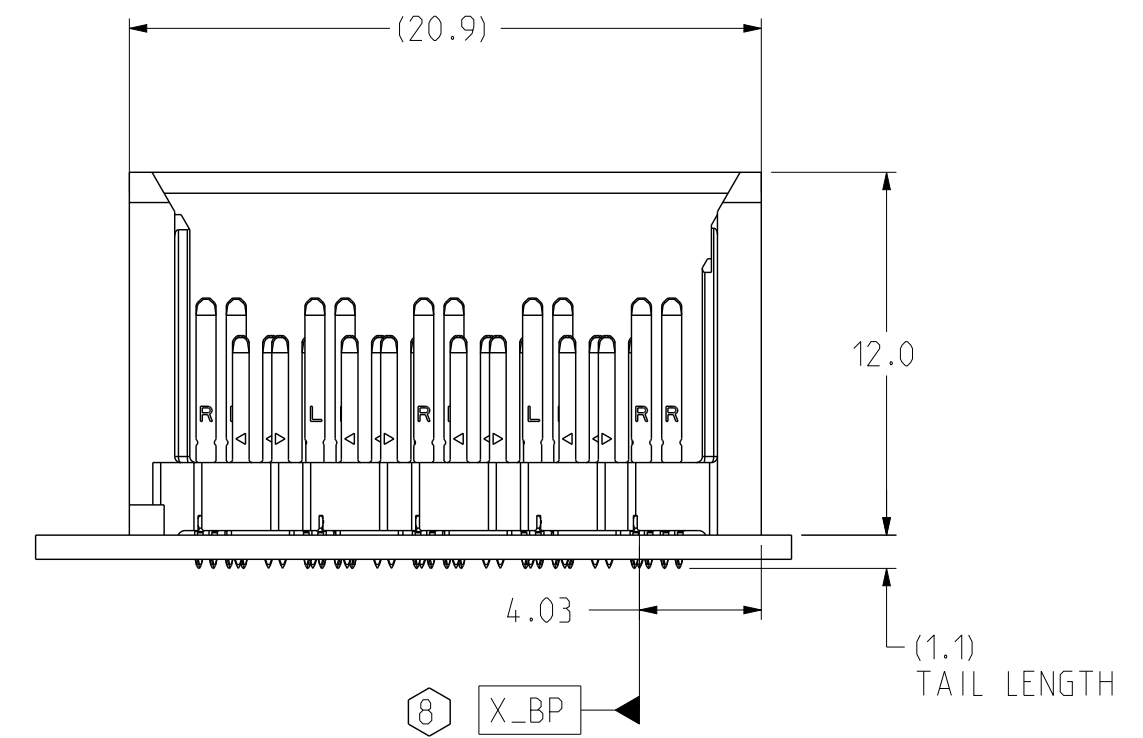

ISOMETRIC VIEW SCALE 3/1

LEFT WALL BACKPLANE MODULE DIMENSION

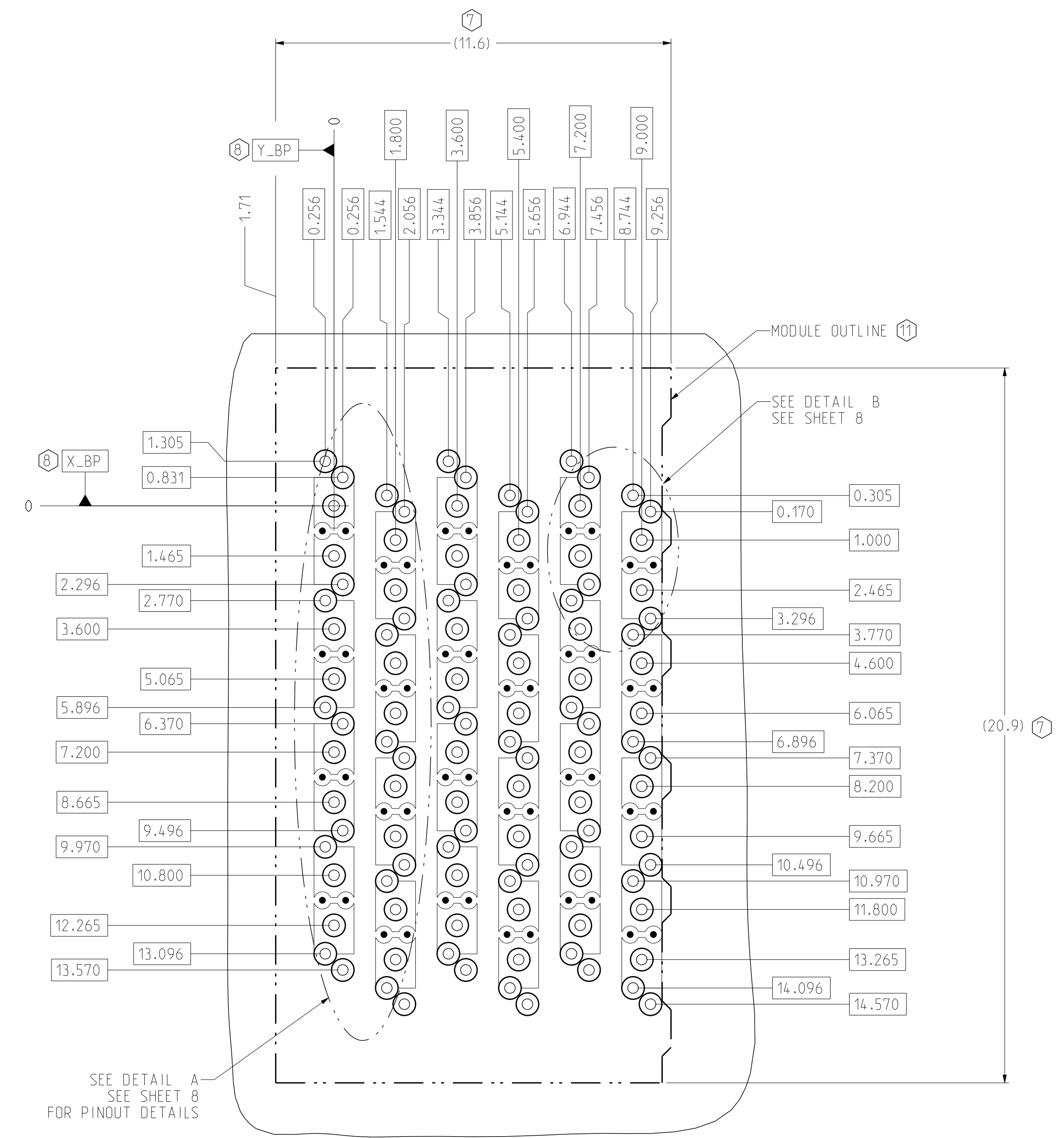

BP HOLE PATTERN COMPONENT SIDE SCALE 10/1

TOLERANCES	DESIGN	11/03/2016	B.W ANG	Amphenol TCS		
0.0	±0.25	DRAWN	11/03/2016	A Division of Amphenol Corporation		
0.00	±0.13	CHK	11/03/2016	200 Innovative Way, Nashua, NH 03082 603.879.3000		
0.000	± -	APVD	11/03/2016	TITLE BACKPLANE MODULES, VERTICAL MALE HEADER XCode HD2, 4 PAIR 6 POS, THICK WALL W/EXTRA GND		
ANGLES	± 3°	PART NO. SEE P/N TREE SHEET 1			REV	N/A
UNLESS OTHERWISE SPECIFIED DIMENSIONS ARE IN MM. DECIMAL MARKER IS A PERIOD				DRAWING NO. C-972-401C-500		
INTERPRET PER ASME Y14.5M				ASSEM C972-401C-500_XG-HD2 0.2		
CODE IDENT 31413				DRAWING C972-401C-500_XG-HD2 0.16		
CUSTOMER USE DRAWING				SIZE	D	SHEET 3 OF 9

DRW NO.	C-972-401C-500	SH	4	REV	H	
ZONE	REV	ECN NUMBER	DESCRIPTION	BY	DATE	APPROVED
			SEE SHEET 1			

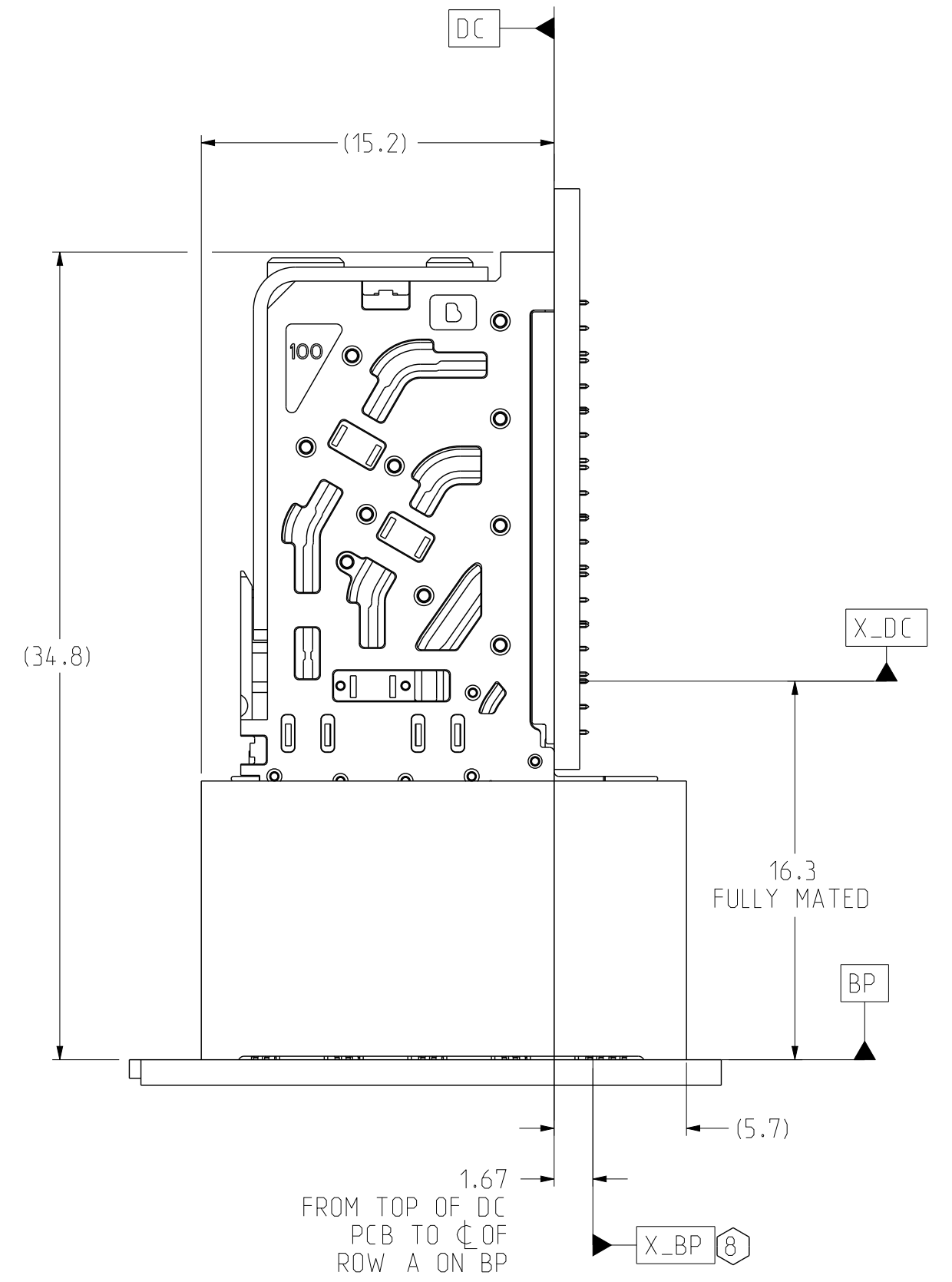
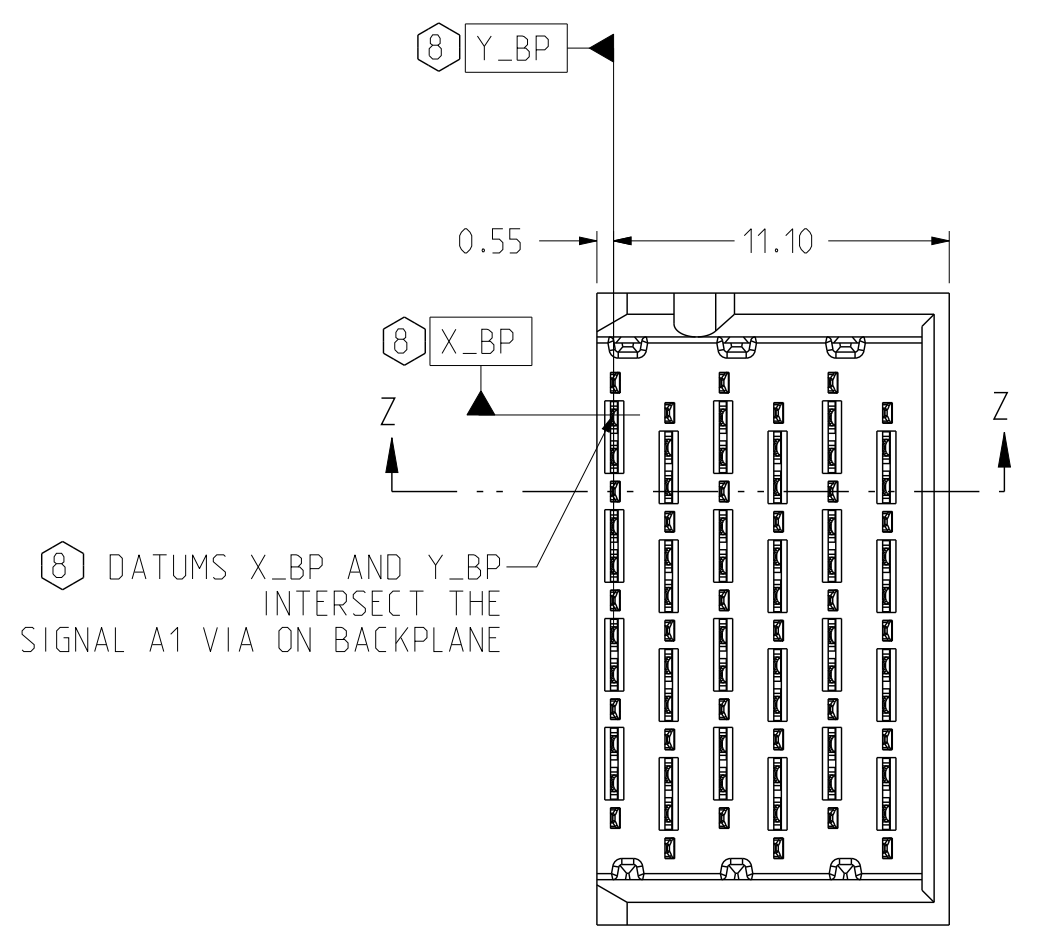

CONNECTOR REFERENCE
SCALE 4/1

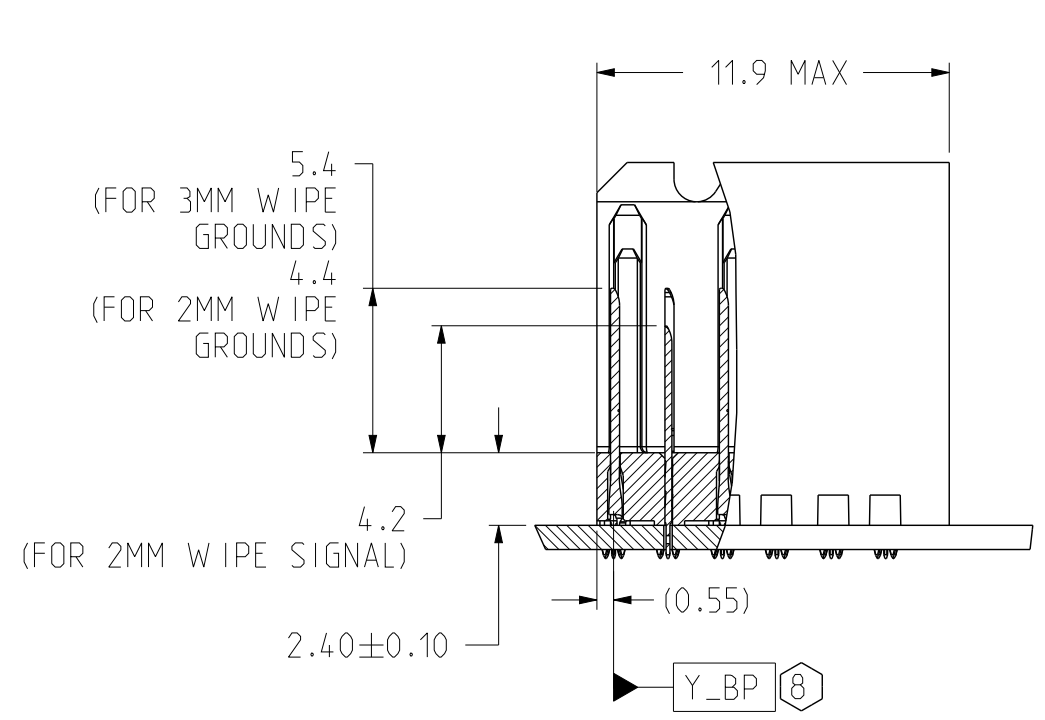

SECTION Z-Z

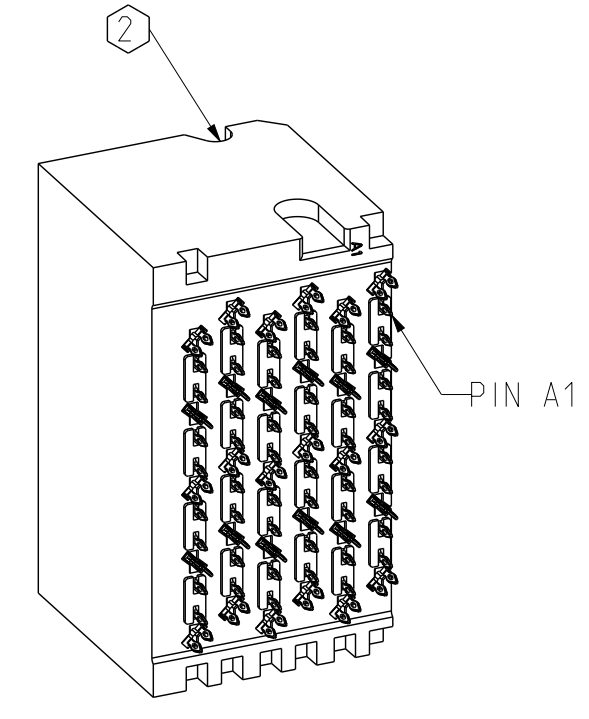
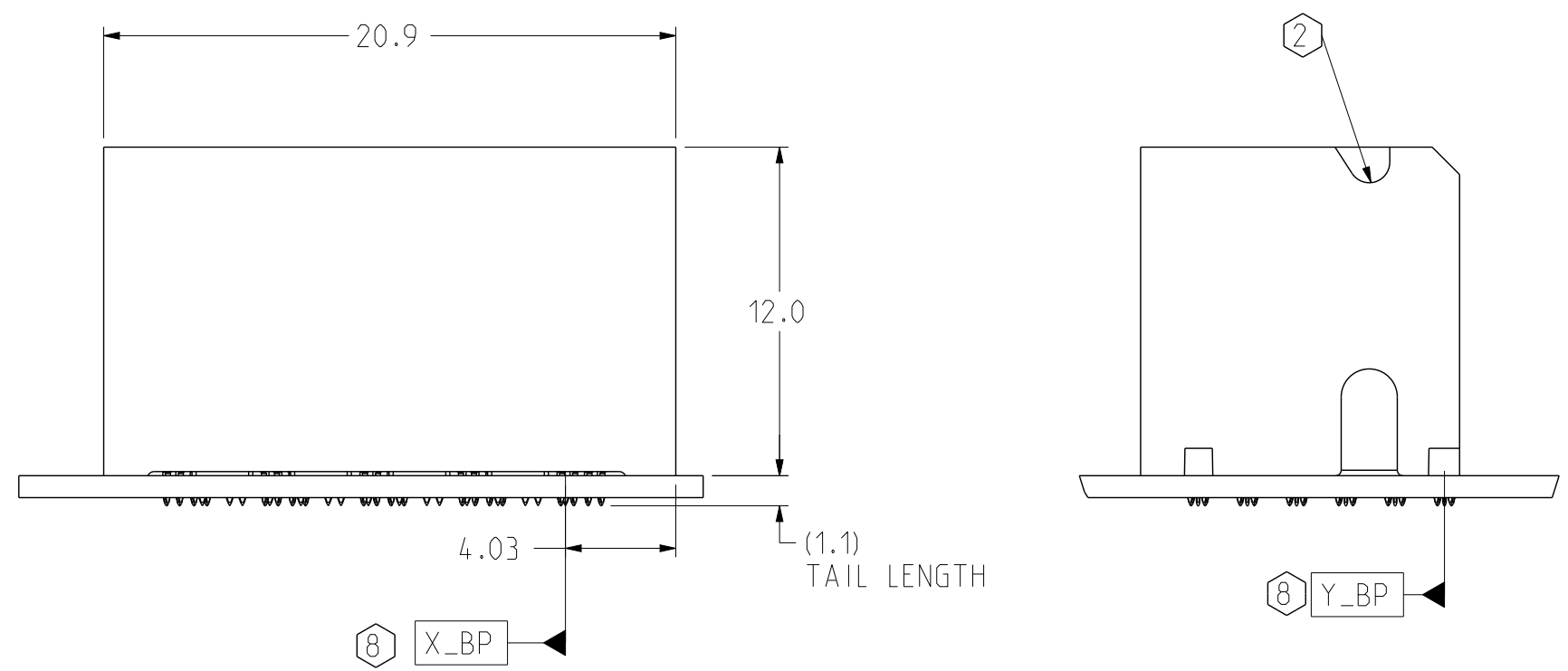

ISOMETRIC VIEW
SCALE 3/1

RIGHT WALL BACKPLANE MODULE DIMENSION

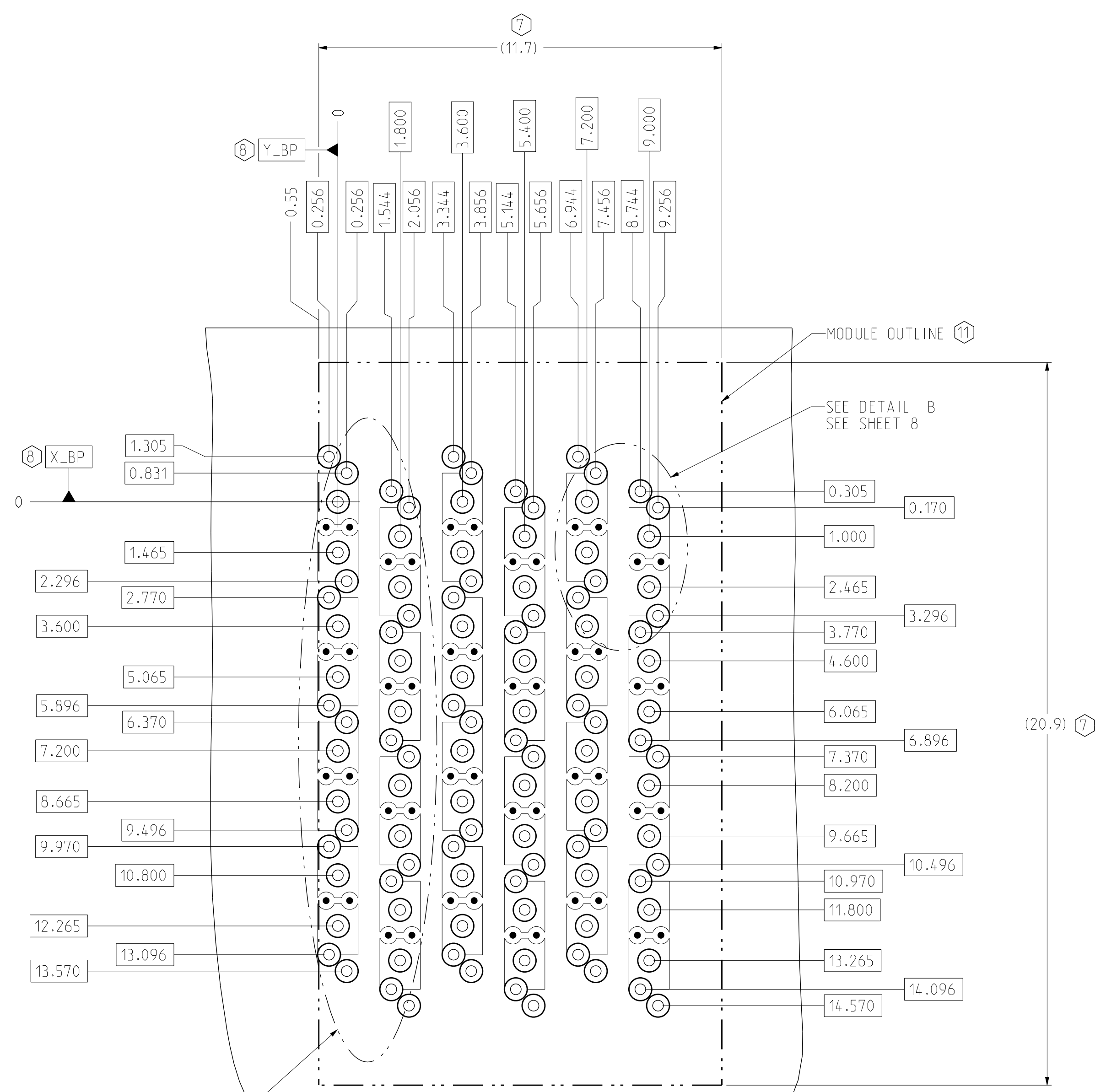

BP_HOLE_PATTERN
COMPONENT_SIDE
SCALE 10/1

TOLERANCES	DESIGN 11/03/2016 B.W ANG	Amphenol TCS A Division of Amphenol Corporation 200 Innovative Way, Nashua, NH 03062 603.879.3000	TITLE	BACKPLANE MODULES, VERTICAL MALE HEADER	
0.0 ±0.25	DRAWN 11/03/2016 HCL-NC		XCede HD2, 4 PAIR 6 POS, THICK WALL W/EXTRA GND	PART NO.	SEE P/N TREE SHEET 1
0.00 ±0.13	CHK 11/03/2016 B.W ANG		UNLESS OTHERWISE SPECIFIED DIMENSIONS ARE IN MM. DECIMAL MARKER IS A PERIOD.	DRAWING NO.	C-972-401C-500
0.000 ± -	APVD 11/03/2016 B.W ANG		ASSEM C972-401C-500_XG-HD2 0.2	REV	H
ANGLES ± 3°			DRAWING C972-401C-500_XG-HD2 0.16		
			SIZE D	SCALE 1/1	SHEET 4 OF 9

INTERPRET PER ASME Y14.5M
CODE IDENT 31413

CUSTOMER USE
DRAWING

ZONE	REV	ECN NUMBER	DESCRIPTION	BY	DATE	APPROVED
			SEE SHEET 1			

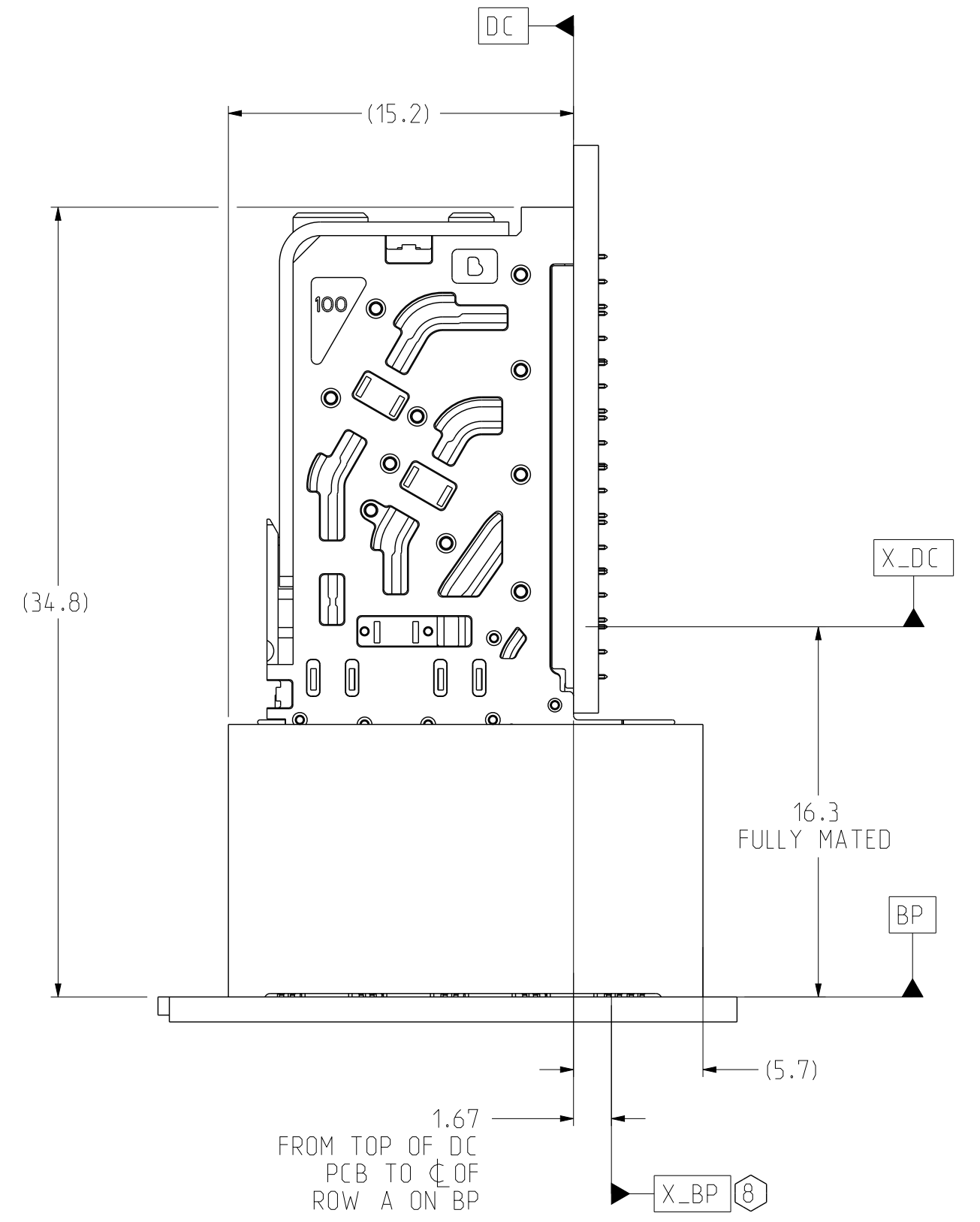
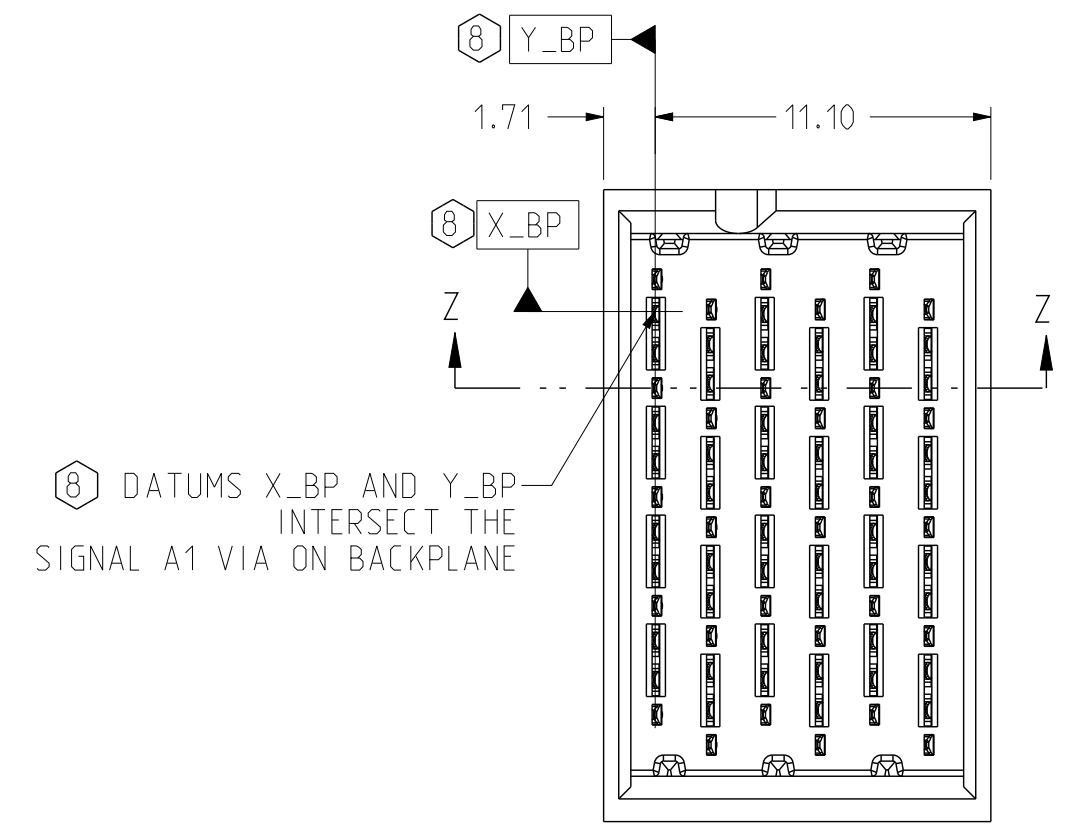

CONNECTOR REFERENCE
SCALE 4/1

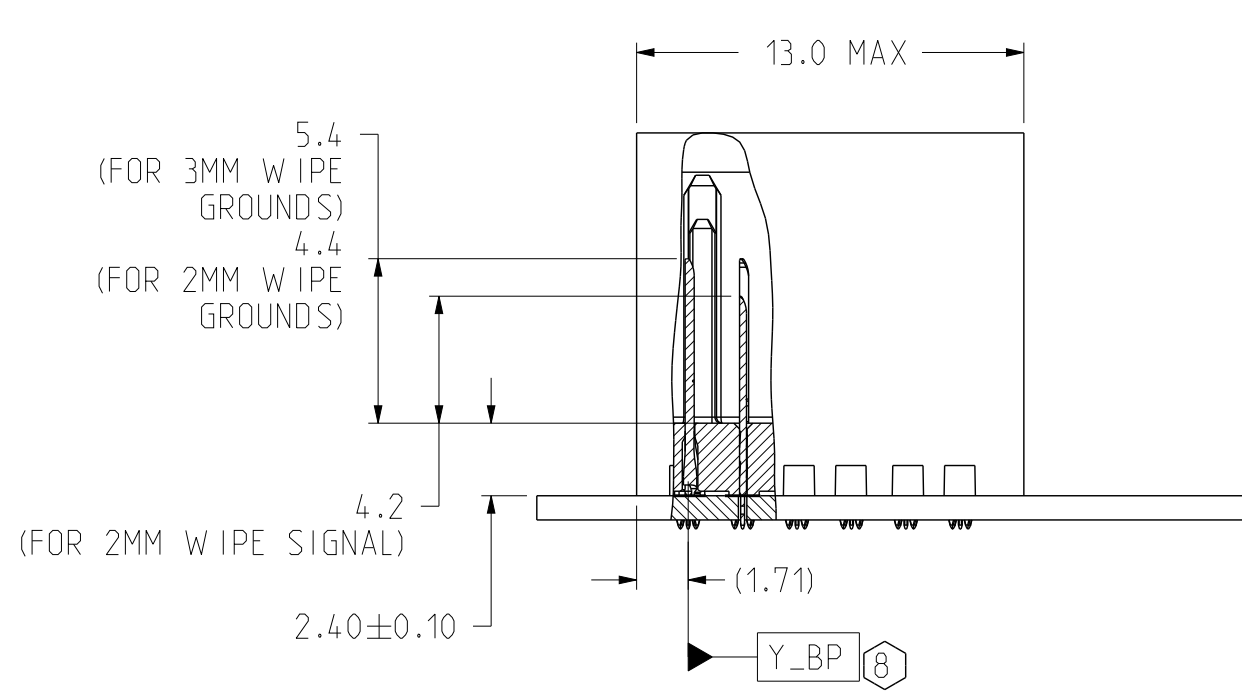

SECTION Z-Z

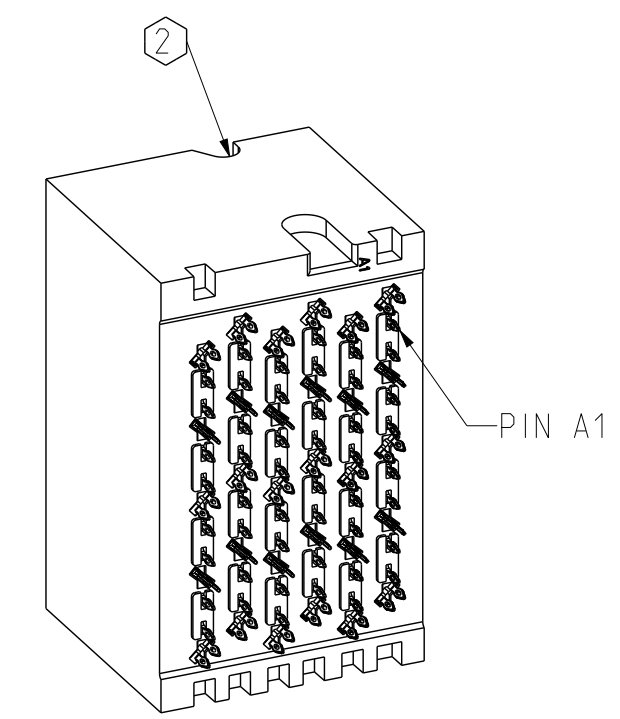
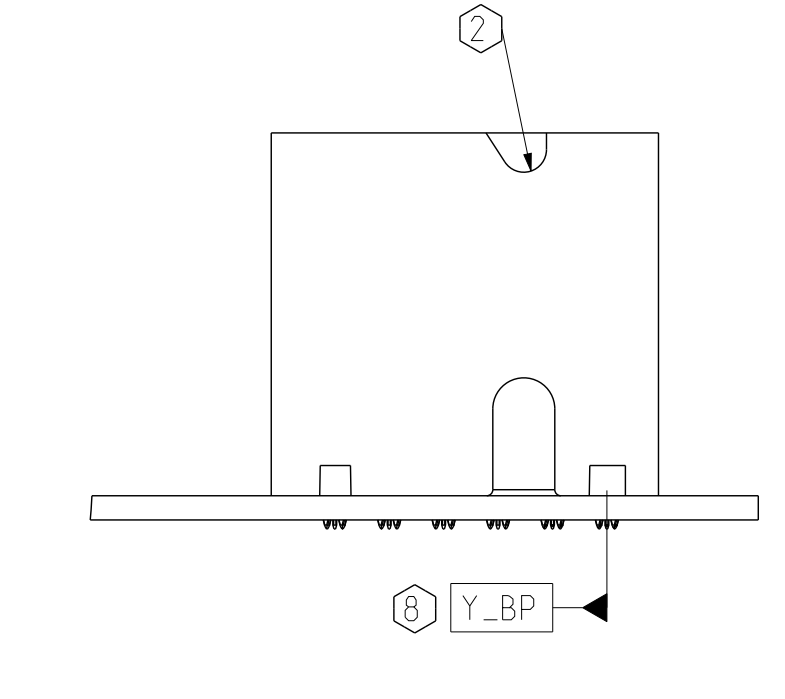
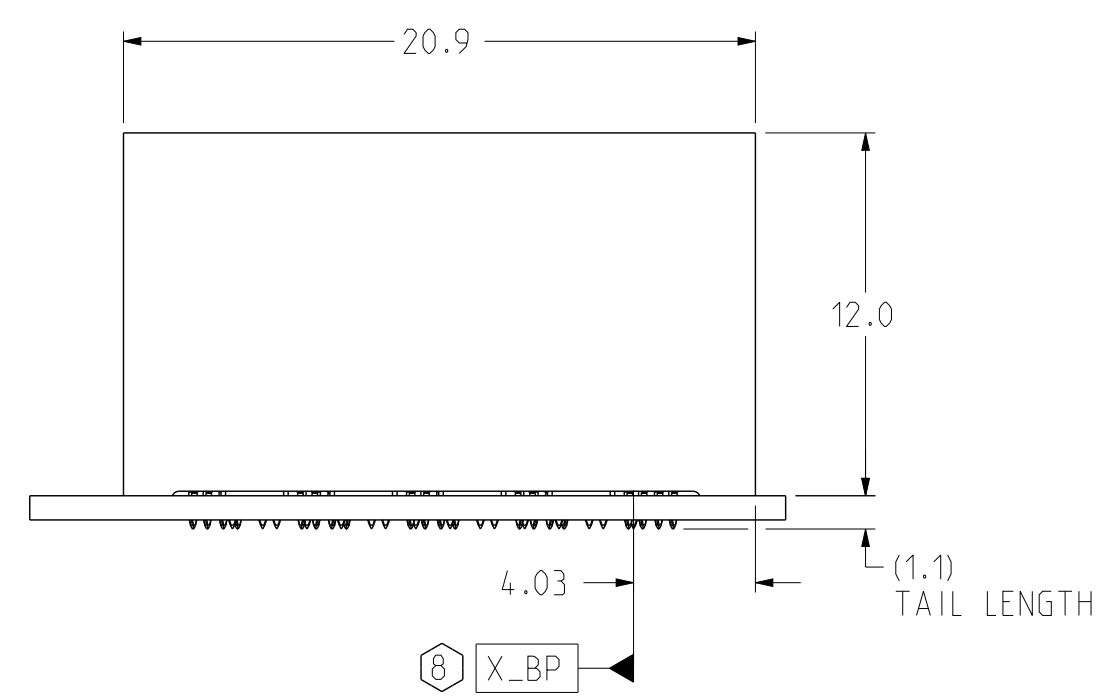

ISOMETRIC VIEW
SCALE 3/1

TWO WALL BACKPLANE MODULE DIMENSION

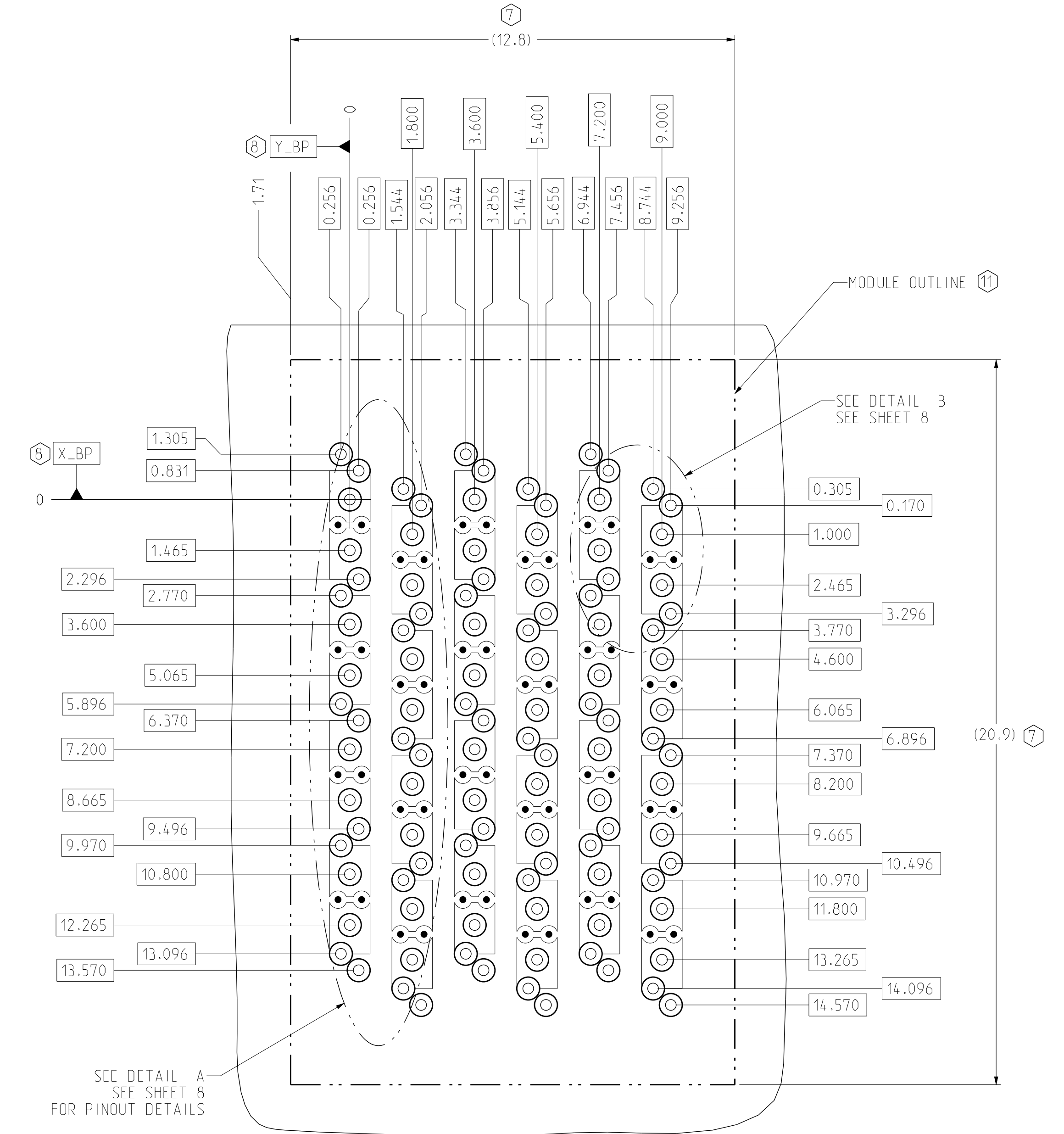

TWO WALL BACKPLANE FOOTPRINT

BP HOLE PATTERN
COMPONENT SIDE
SCALE 10/1

TOLERANCES	DESIGN	11/03/2016	B.W ANG	Amphenol TCS A Division of Amphenol Corporation 200 Innovative Way, Nashua, NH 03062 603.879.3000	
0.0	±0.25	DRAWN	11/03/2016		HCL-NC
0.00	±0.13	CHK	11/03/2016		B.W ANG
0.000	± -	APVD	11/03/2016		B.W ANG
ANGLES	± 3°			TITLE BACKPLANE MODULES, VERTICAL MALE HEADER Xcde HD2, 4 PAIR 6 POS, THICK WALL W/EXTRA GND	
UNLESS OTHERWISE SPECIFIED DIMENSIONS ARE IN MM. DECIMAL MARKER IS A PERIOD				PART NO. SEE P/N TREE SHEET 1	REV N/A
DRAWING NO. C-972-401C-500				ASSEM C972-401C-500_XG-HD2 DRAWING C972-401C-500_XG-HD2	0.2 0.16
SIZE D		SCALE 1/1		SHEET 5 OF 9	

INTERPRET PER ASME Y14.5M
CODE IDENT 31413

CUSTOMER USE
DRAWING

8

7

6

5

4

3

8

7

6

5

4

3

2

1

ZONE	REV	ECN NUMBER	DESCRIPTION	BY	DATE	APPROVED
			SEE SHEET 1			

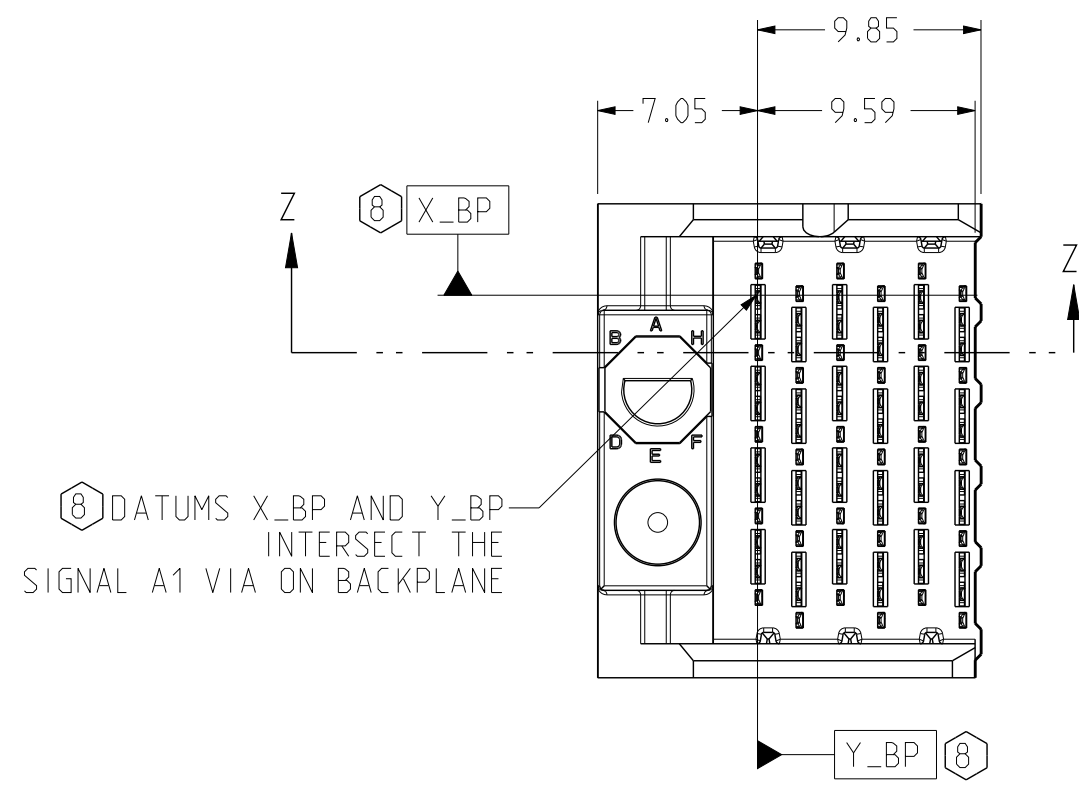
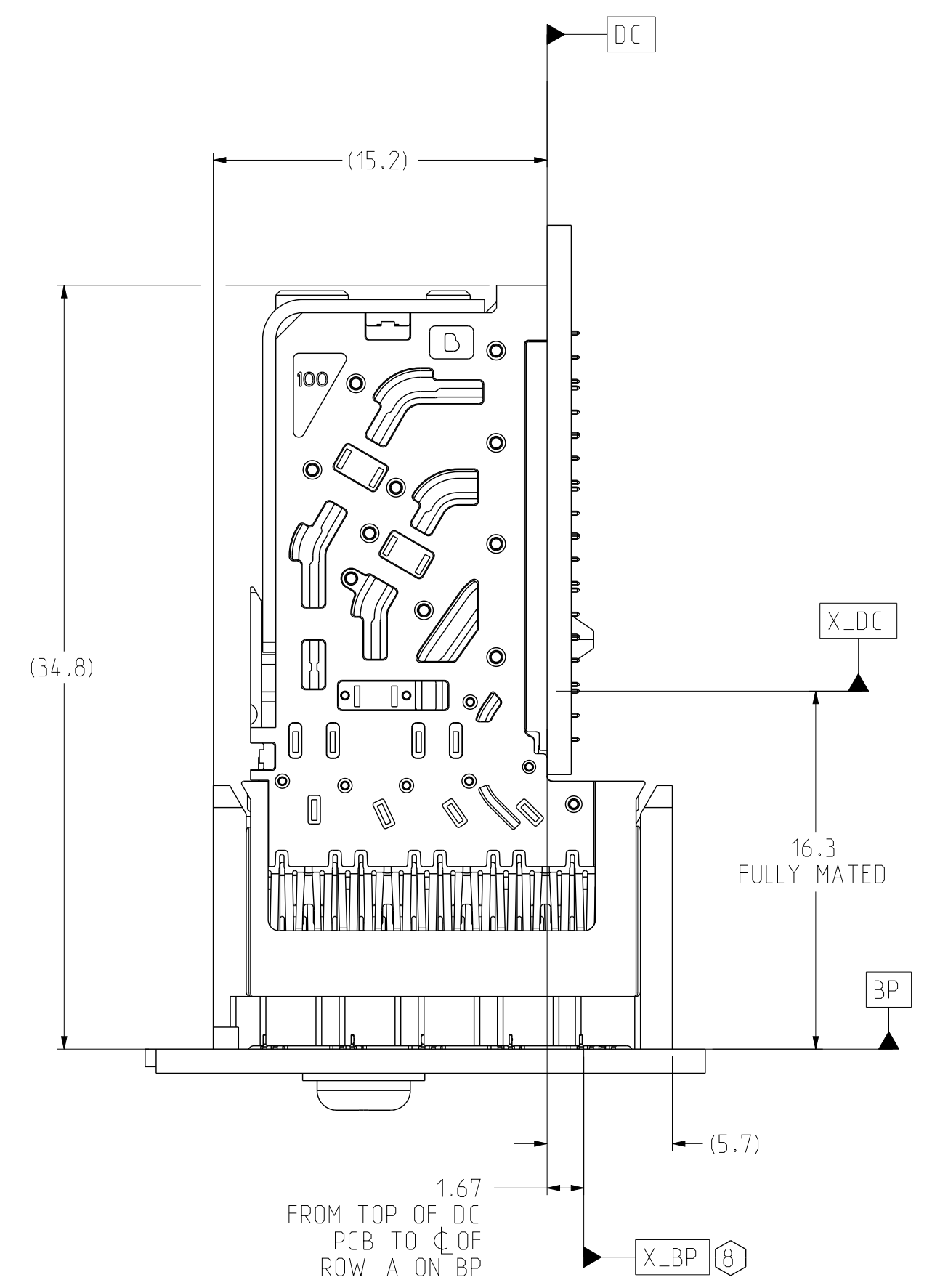

DATUMS X_BP AND Y_BP INTERSECT THE SIGNAL A1 VIA ON BACKPLANE

CONNECTOR REFERENCE SCALE 4/1

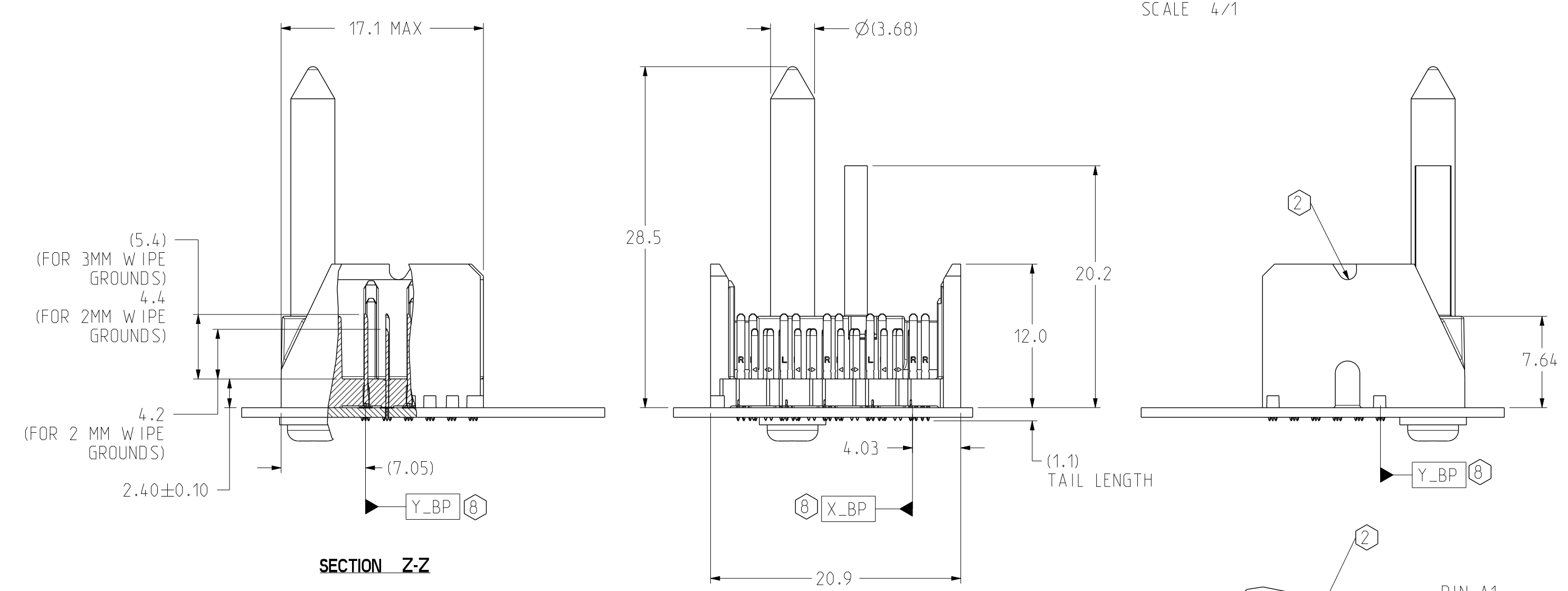

SECTION Z-Z

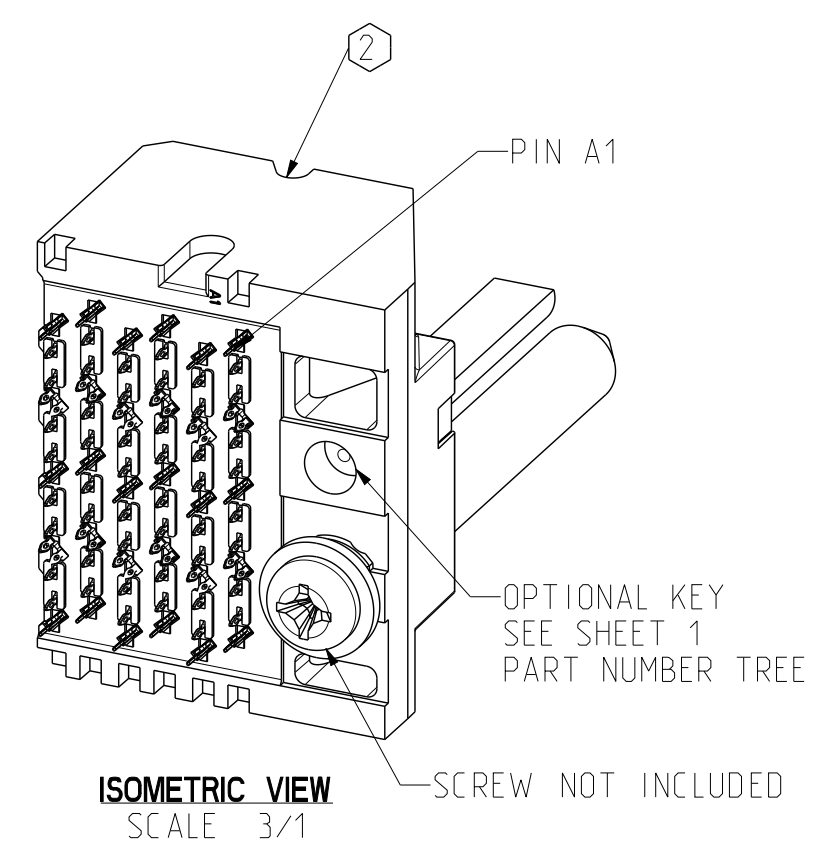

ISOMETRIC VIEW SCALE 3/1

LEFT POLARIZING/GUIDE BACKPLANE MODULE DIMENSION

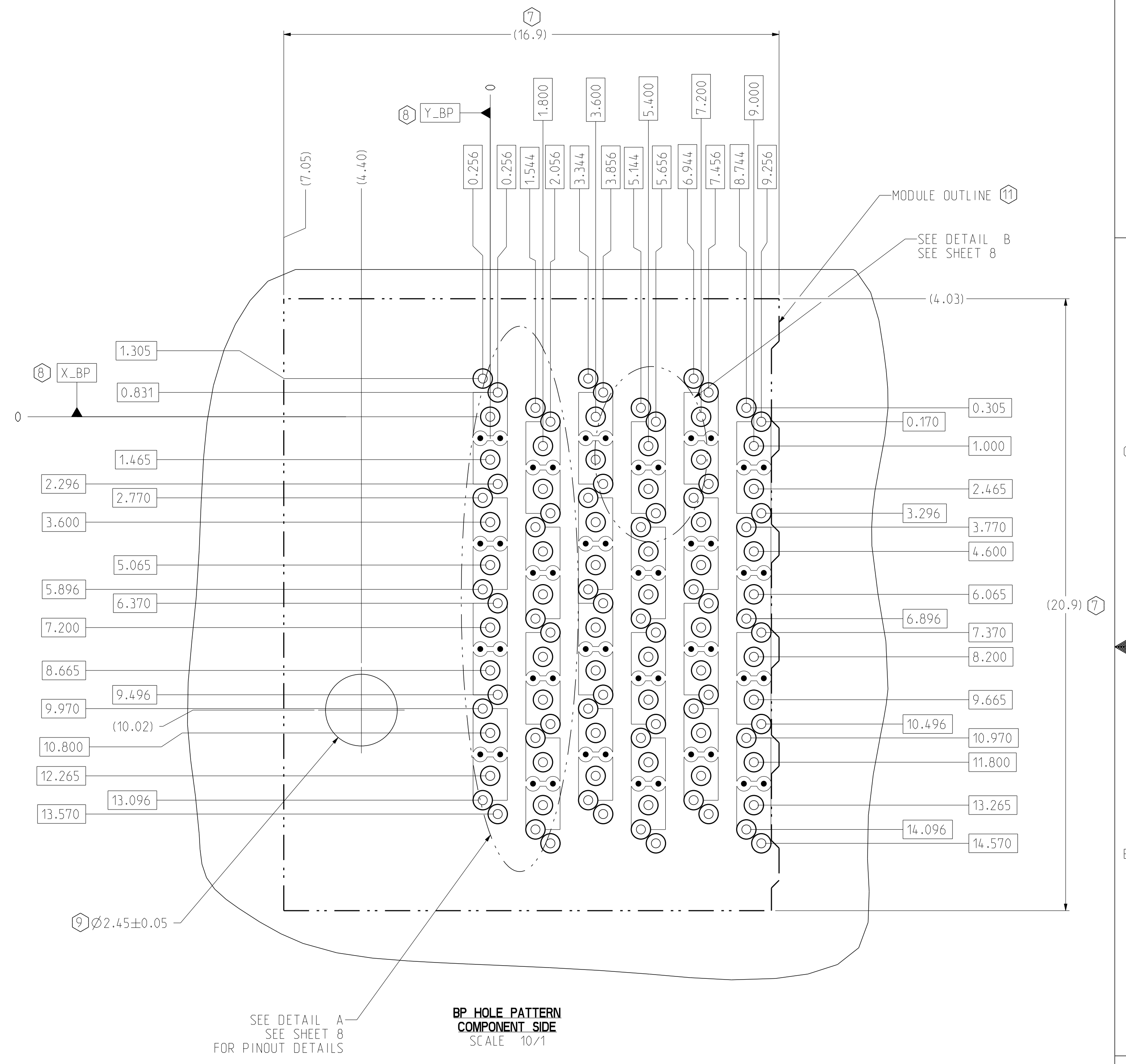

BP HOLE PATTERN COMPONENT SIDE SCALE 10/1

SEE DETAIL A SEE SHEET 8 FOR PINOUT DETAILS

TOLERANCES	DESIGN 11/03/2016 B.W ANG	Amphenol TCS A Division of Amphenol Corporation 200 Innovative Way, Nashua, NH 03062 603.879.3000 TITLE BACKPLANE MODULES, VERTICAL MALE HEADER XCode HD2, 4 PAIR 6 POS, THICK WALL W/EXTRA GND PART NO. SEE P/N TREE SHEET 1 DRAWING NO. C-972-401C-500 ASSEM C972-401C-500_XG-HD2 0.2 DRAWING C972-401C-500_XG-HD2 0.16 SIZE D SCALE 1/1 SHEET 6 OF 9
0.0 ±0.25	DRAWN 11/03/2016 HCL-NC	
0.00 ±0.13	CHK 11/03/2016 B.W ANG	
0.000 ± -	APVD 11/03/2016 B.W ANG	
ANGLES ± 3°		

INTERPRET PER ASME Y14.5M
CODE IDENT 31413

CUSTOMER USE DRAWING

ZONE	REV	ECN NUMBER	DESCRIPTION	BY	DATE	APPROVED
			SEE SHEET 1			

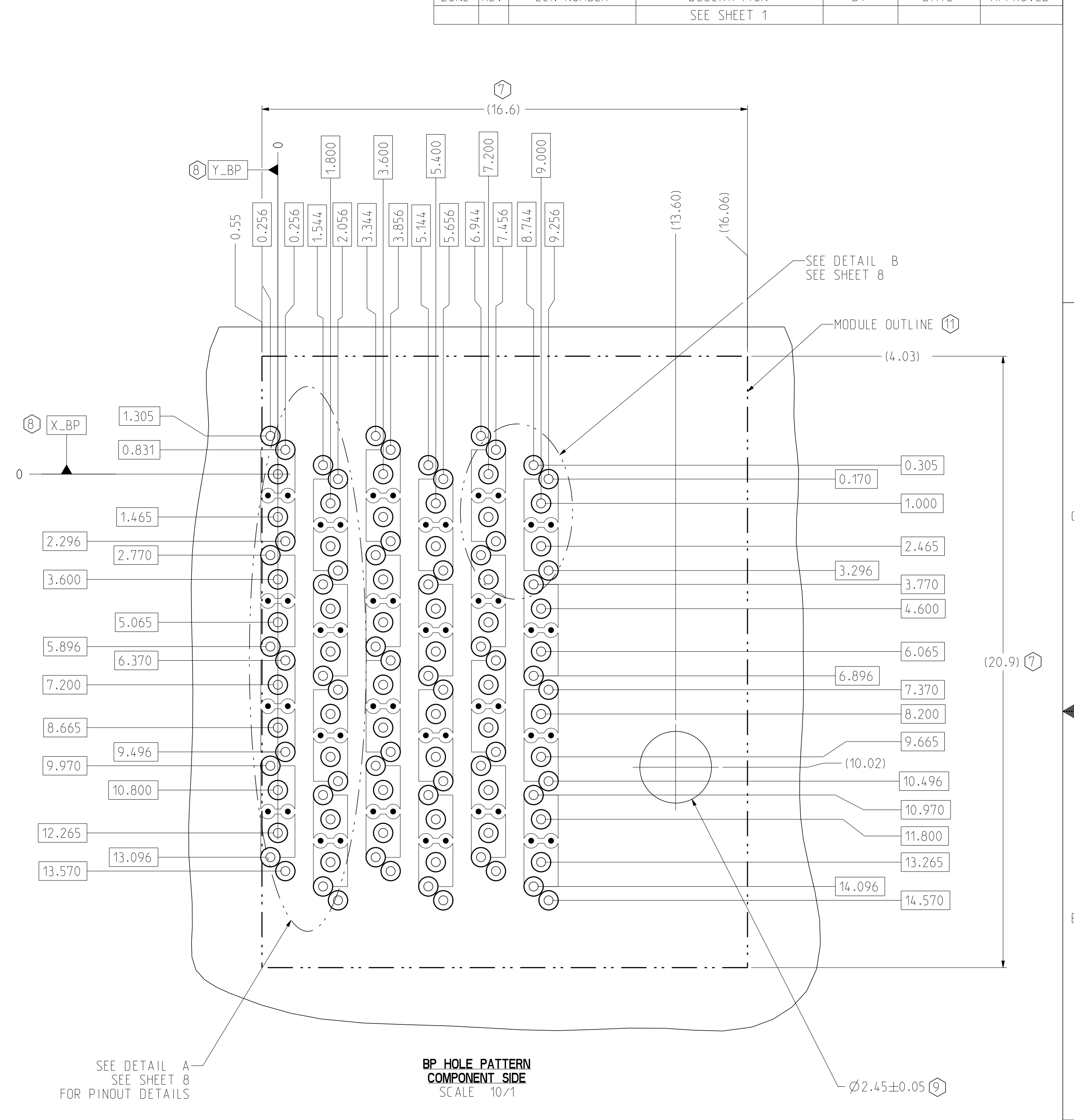
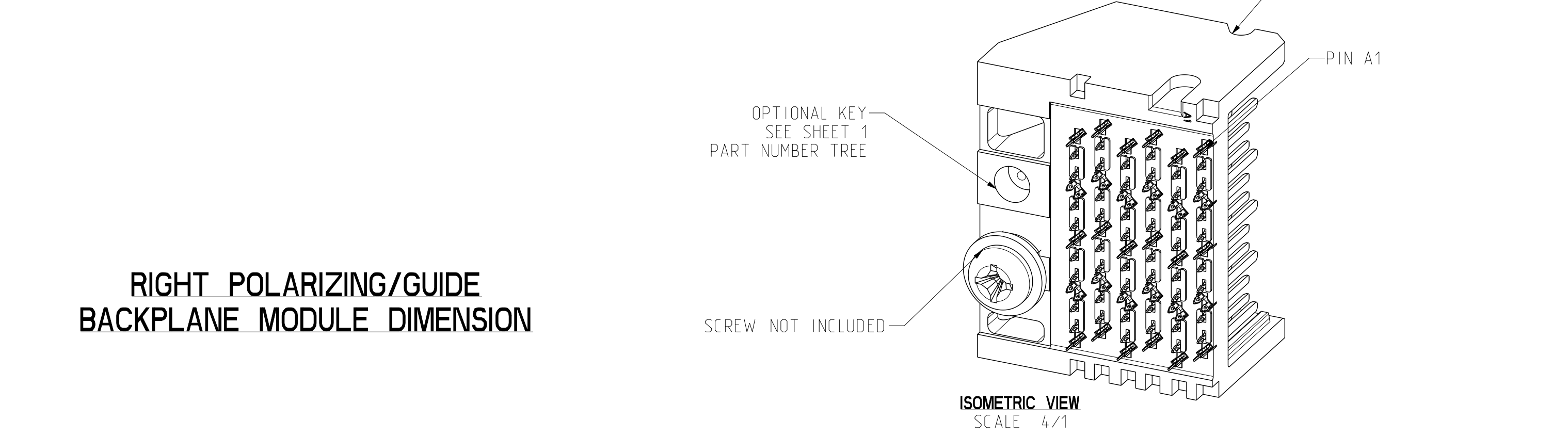
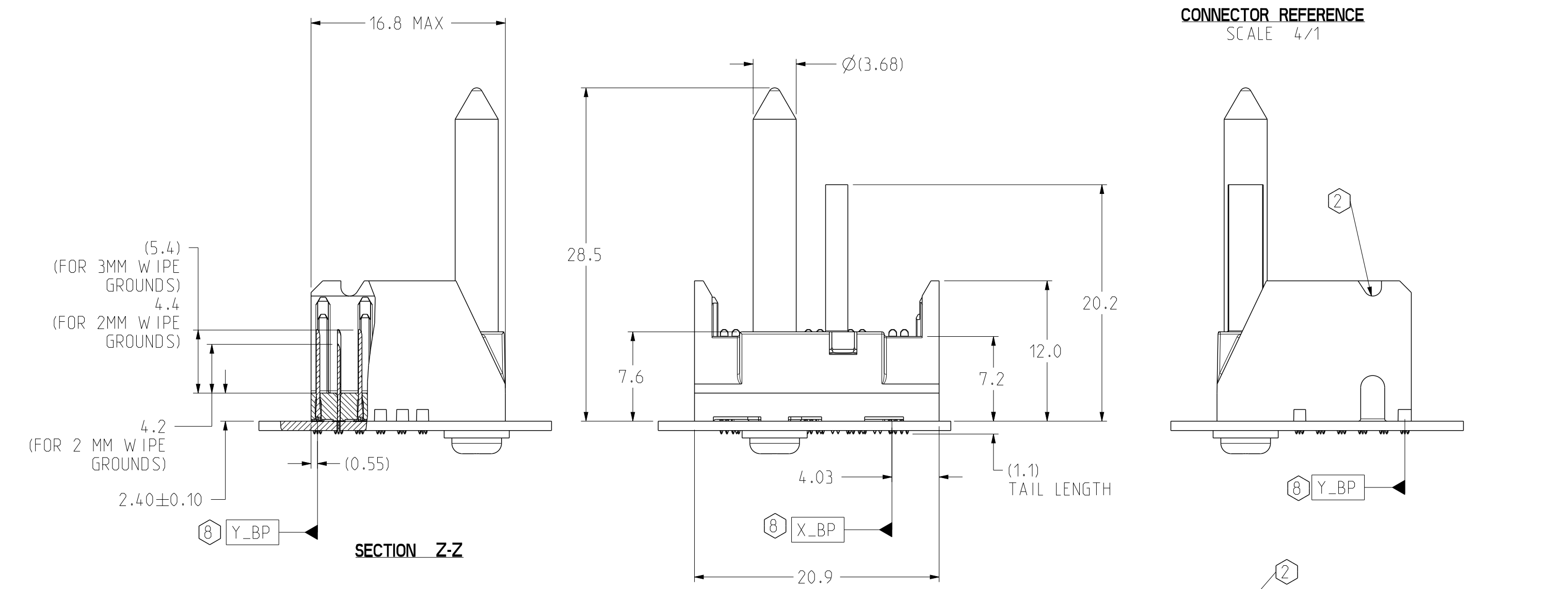
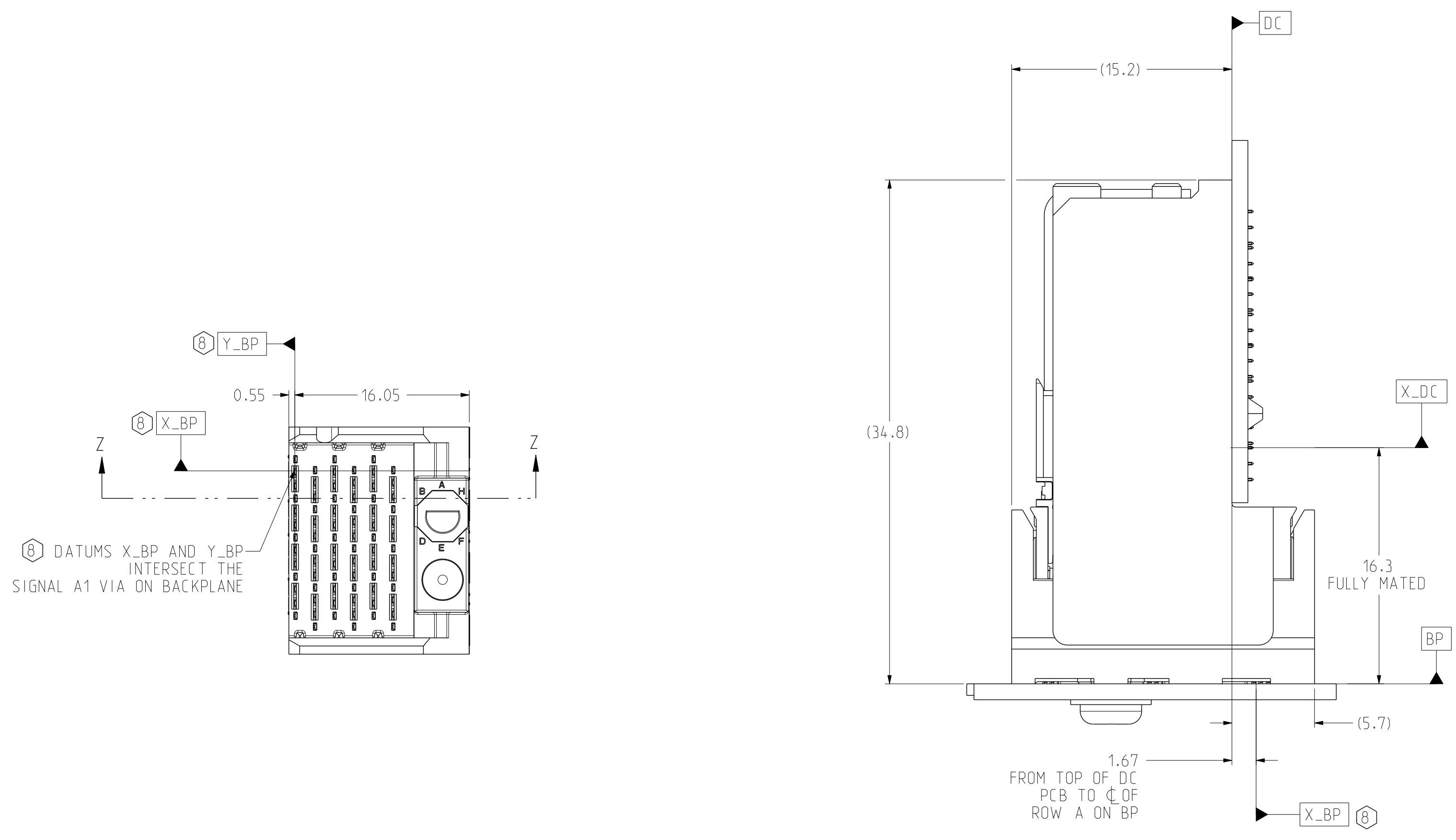

RIGHT POLARIZING/GUIDE BACKPLANE MODULE DIMENSION

TOLERANCES	DESIGN	11/03/2016	B.W ANG	Amphenol TCS A Division of Amphenol Corporation 200 Innovative Way, Nashua, NH 03062 603.879.3000 TITLE BACKPLANE MODULES, VERTICAL MALE HEADER XCode HD2, 4 PAIR 6 POS, THICK WALL W/EXTRA GND PART NO. SEE P/N TREE SHEET 1 DRAWING NO. C-972-401C-500 ASSEM C972-401C-500_XG-HD2 0.2 DRAWING C972-401C-500_XG-HD2 0.16 SIZE D SCALE 1/1 SHEET 7 OF 9	
0.0	±0.25	DRAWN	11/03/2016		REV N/A
0.00	±0.13	CHK	11/03/2016		REV H
0.000	± -	APVD	11/03/2016		

UNLESS OTHERWISE SPECIFIED DIMENSIONS ARE IN MM. DECIMAL MARKER IS A PERIOD.

INTERPRET PER ASME Y14.5M
 CODE IDENT 31413

CUSTOMER USE DRAWING

ZONE	REV	ECN NUMBER	DESCRIPTION	BY	DATE	APPROVED
			SEE SHEET 1			

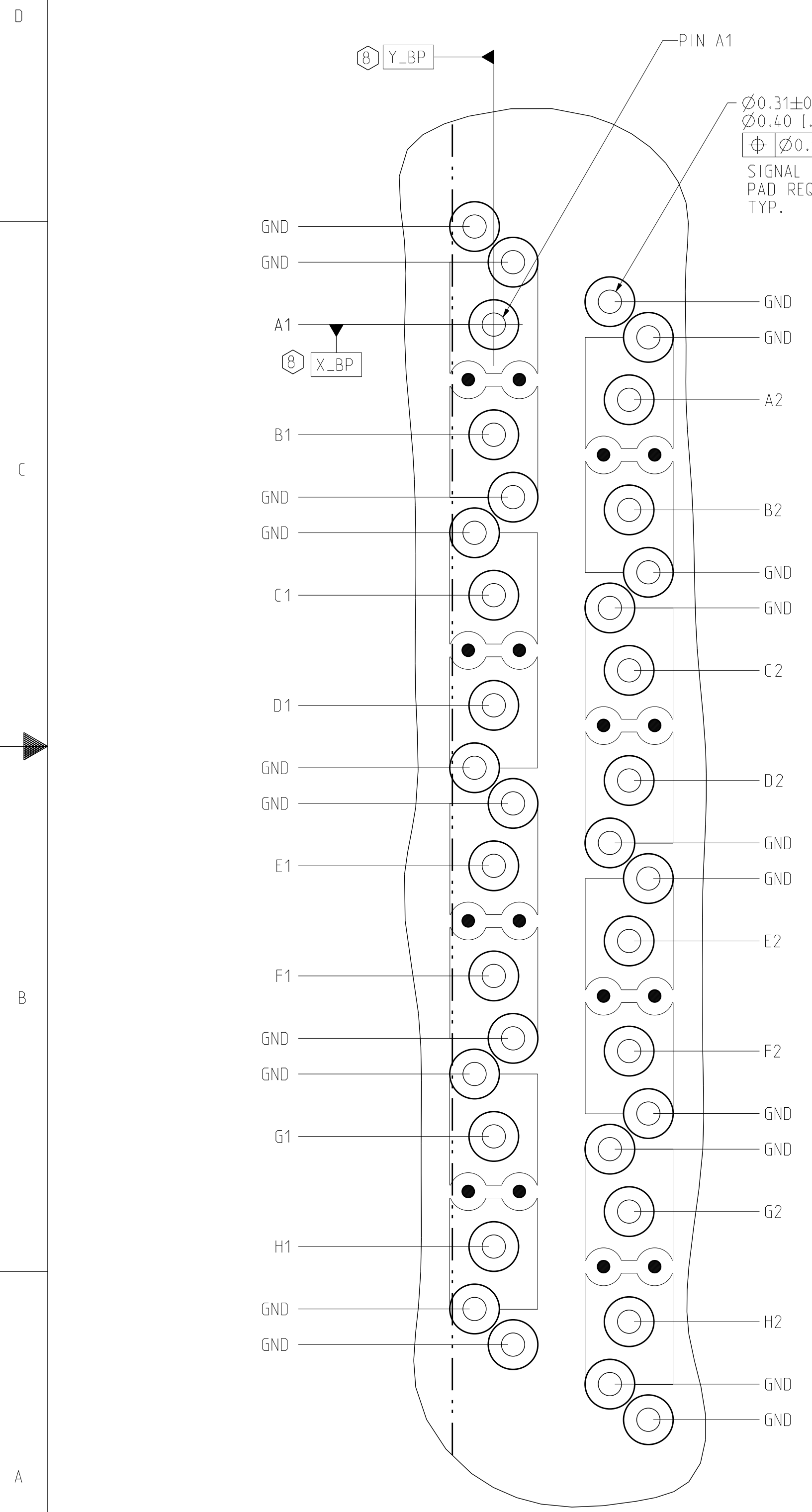

Ø0.31±0.05 PTH
Ø0.40 [1.0157"] DRILL
Ø0.10 X_BP Y_BP
SIGNAL AND GROUND PIN HOLES
PAD REQUIRED SEE NOTE
TYP.

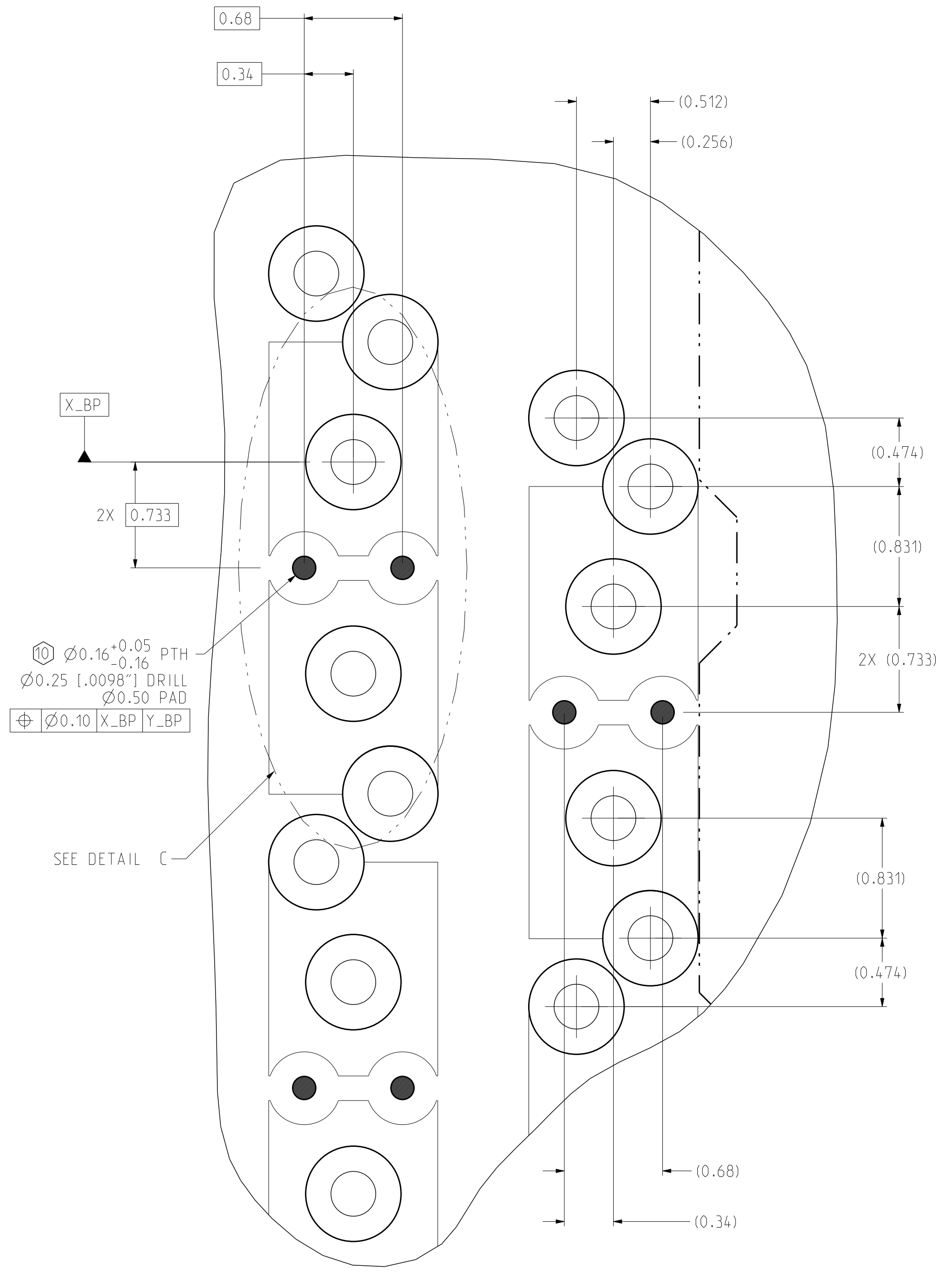

Ø0.16^{+0.05}_{-0.16} PTH
Ø0.25 [1.0098"] DRILL
Ø0.50 PAD
Ø0.10 X_BP Y_BP

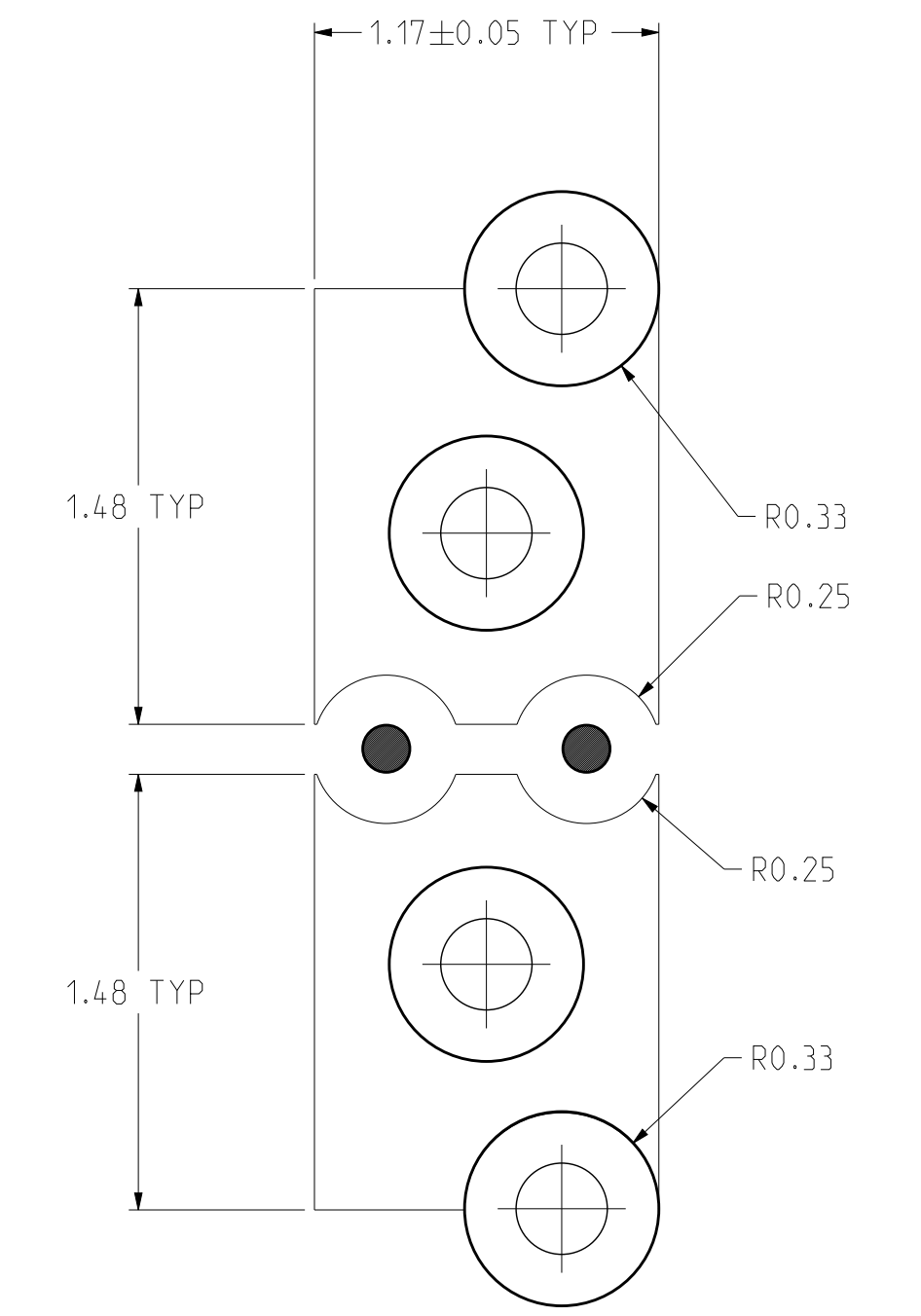

TOLERANCES	DESIGN	11/03/2016	B.W ANG	Amphenol TCS A Division of Amphenol Corporation 200 Innovative Way, Nashua, NH 03062 603.879.3000	
0.0	±0.25	DRAWN	11/03/2016		HCL-NC
0.00	±0.13	CHK	11/03/2016		B.W ANG
0.000	± -	APVD	11/03/2016		B.W ANG
UNLESS OTHERWISE SPECIFIED DIMENSIONS ARE IN MM. DECIMAL MARKER IS A PERIOD				TITLE BACKPLANE MODULES, VERTICAL MALE HEADER XCode HD2, 4 PAIR 6 POS, THICK WALL W/EXTRA GND	
INTERPRET PER ASME Y14.5M CODE IDENT 31413			PART NO. SEE P/N TREE SHEET 1		
CUSTOMER USE DRAWING			DRAWING NO. C-972-401C-500		
			ASSEM C972-401C-500_XG-HD2 0.2 DRAWING C972-401C-500_XG-HD2 0.16		
SIZE D		SCALE 1/1		SHEET 8 OF 9	

ZONE	REV	ECN NUMBER	DESCRIPTION	BY	DATE	APPROVED
			SEE SHEET 1			

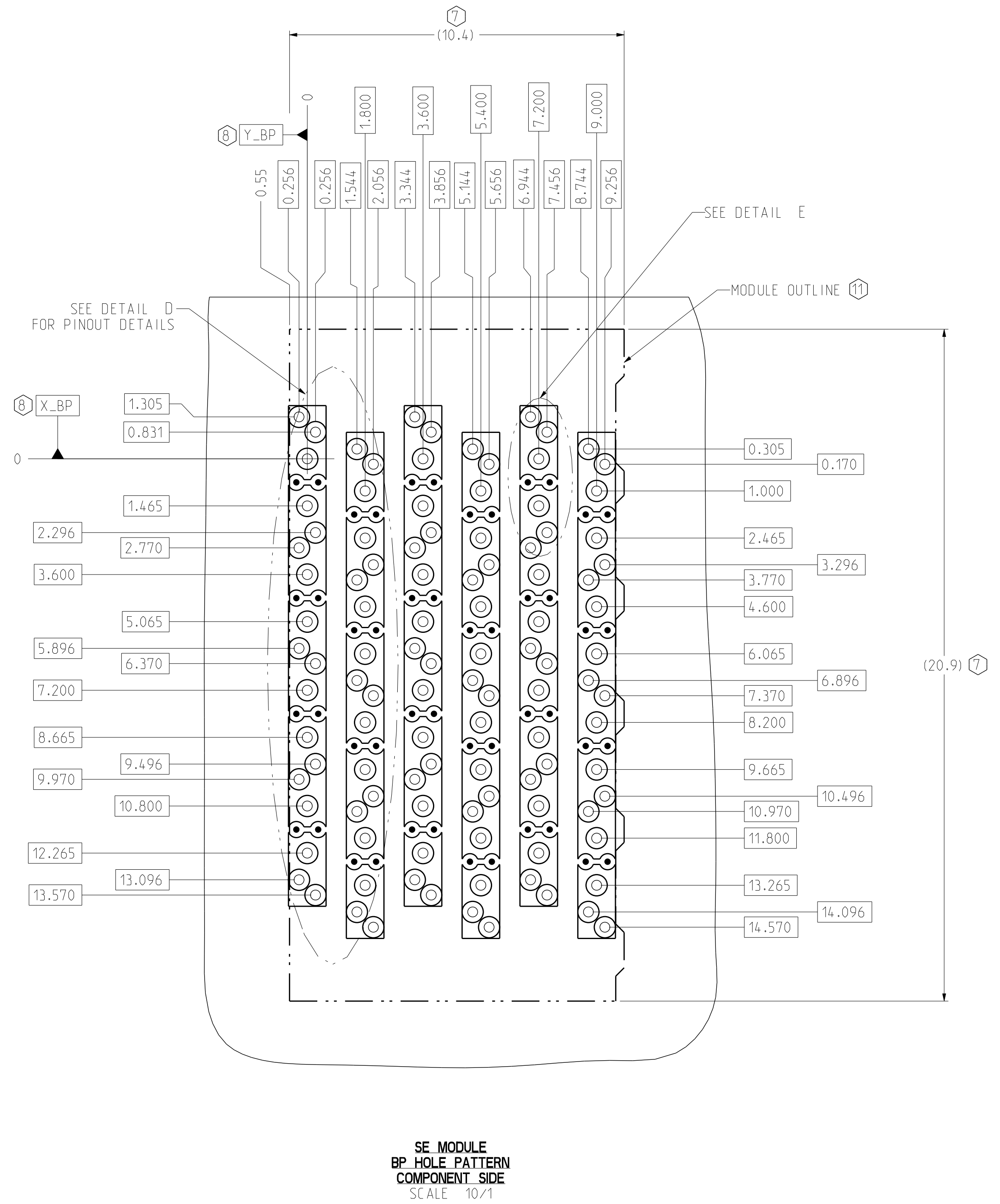

SE MODULE
BP_HOLE PATTERN
COMPONENT SIDE
SCALE 10/1

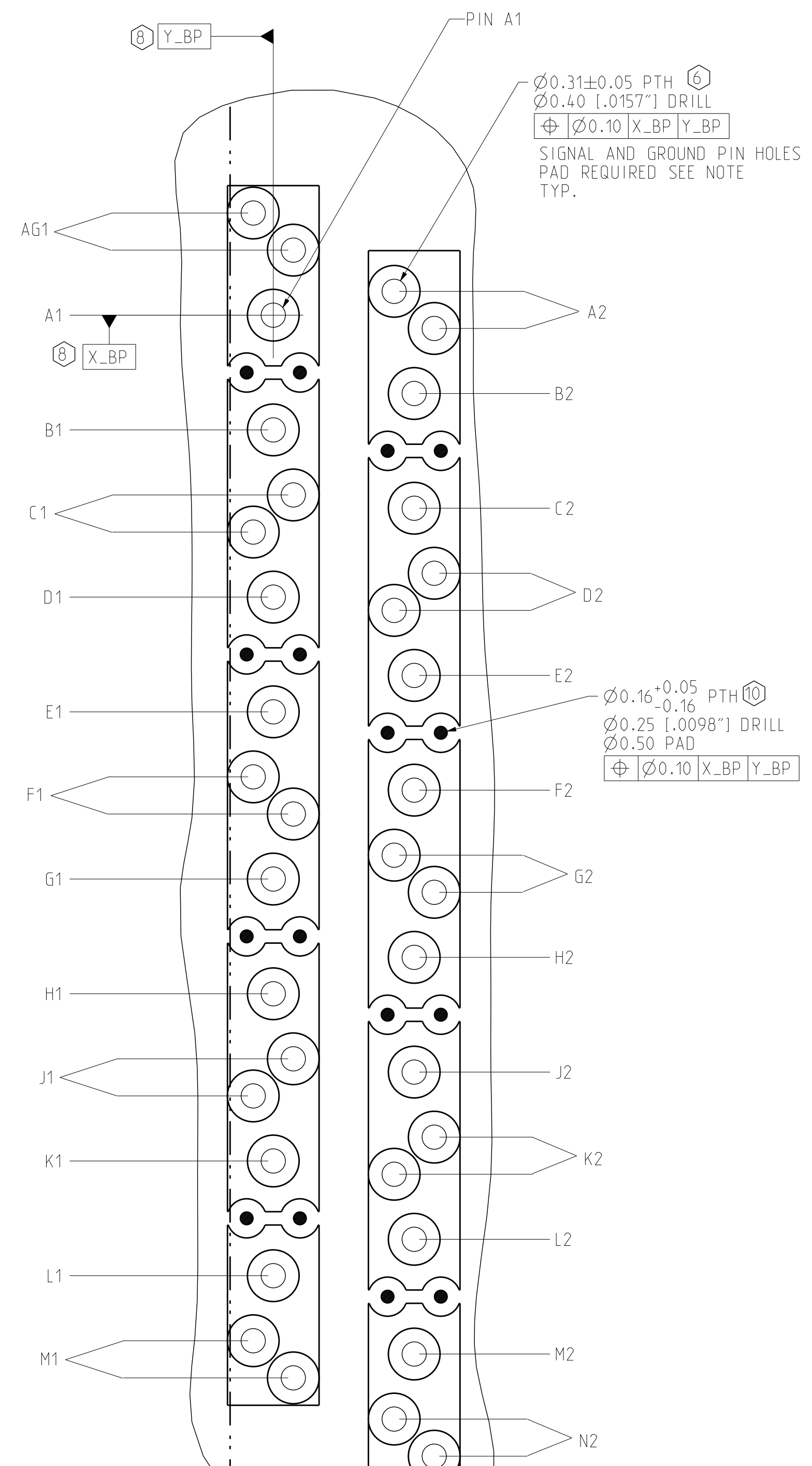

DETAIL D
SE PINOUT DETAILS
SCALE 20/1

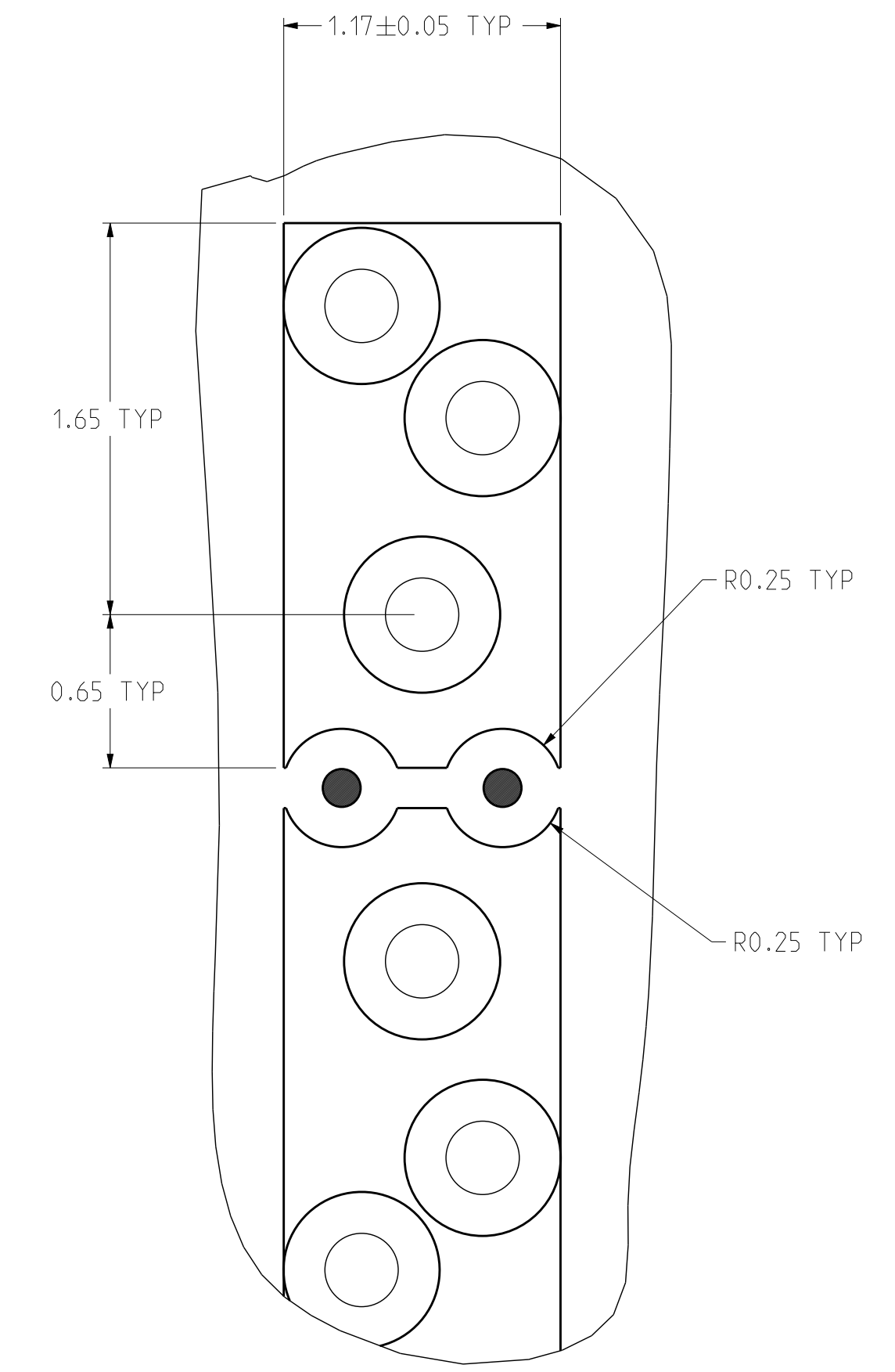

DETAIL E
SE ANTIPAD DETAILS
GROUND AND SHADOW VIAS CAN BE CONNECTED AS
ONE CONTINUOUS SURFACE PAD
SCALE 40/1

TOLERANCES	DESIGN 11/03/2016 B.W ANG	Amphenol TCS A Division of Amphenol Corporation 200 Innovative Way, Nashua, NH 03082 603.879.3000 TITLE BACKPLANE MODULES, VERTICAL MALE HEADER Xcde HD2, 4 PAIR 6 POS, THICK WALL W/EXTRA GND PART NO. SEE P/N TREE SHEET 1 REV N/A
0.0	±0.25 DRAWN 11/03/2016 HCL-NC	
0.00	±0.13 CHK 11/03/2016 B.W ANG	
0.000	± - APVD 11/03/2016 B.W ANG	
ANGLES	± 3°	
UNLESS OTHERWISE SPECIFIED DIMENSIONS ARE IN MM. DECIMAL MARKER IS A PERIOD		DRAWING NO. C-972-401C-500 ASSEM C972-401C-500_XG-HD2 0.2 DRAWING C972-401C-500_XG-HD2 0.16 SIZE D SCALE 1/1 SHEET 9 OF 9

INTERPRET PER ASME Y14.5M
CODE IDENT 31413

CUSTOMER USE
DRAWING