

# Battery Indicator Multi-Color

multicomp **PRO**

RoHS  
Compliant

## Features

### 1. Display

- Battery level display mode: 10 LED segment, 1red, 2yellow and 7green.

### 2. Battery level testing function

- When the key switch is connected, it will display the remaining the battery capacity automatically.
- Delay function (can customize): Decline one LED by one LED per 155s when discharging.
- Rise one LED by LED per 200s when charging.
- Can customize different battery types.

### 3. Output function (can customize)

- Battery capacity  $\geq 10\%$ , relay will be NC; Battery capacity  $< 10\%$ , relay will be NO.



## Specification

Operating voltage	: DC 12V / 24V / 36V / 48V
Working voltage	: DC 9-60V
Working temperature	: -20°C to +65°C
Display screen	: 10 Segment LED Bar Graph
Operation current	: $\leq 100\text{mA}$ nominal
Pin material	: Copper
Pin type	: Positive, Negative, C, Output
Voltage accuracy	: $\pm 0.5\%$
Charging delay time	: 200s
Delay time of every bar	: 155s
Screen size	: 25.5mm $\times$ 7.6mm
Product dimension	: 48mm $\times$ 24mm $\times$ 34.1mm
Applicable type of battery	: Lead-acid Battery (Depending on model)
Housing material	: ABS

## Diagram

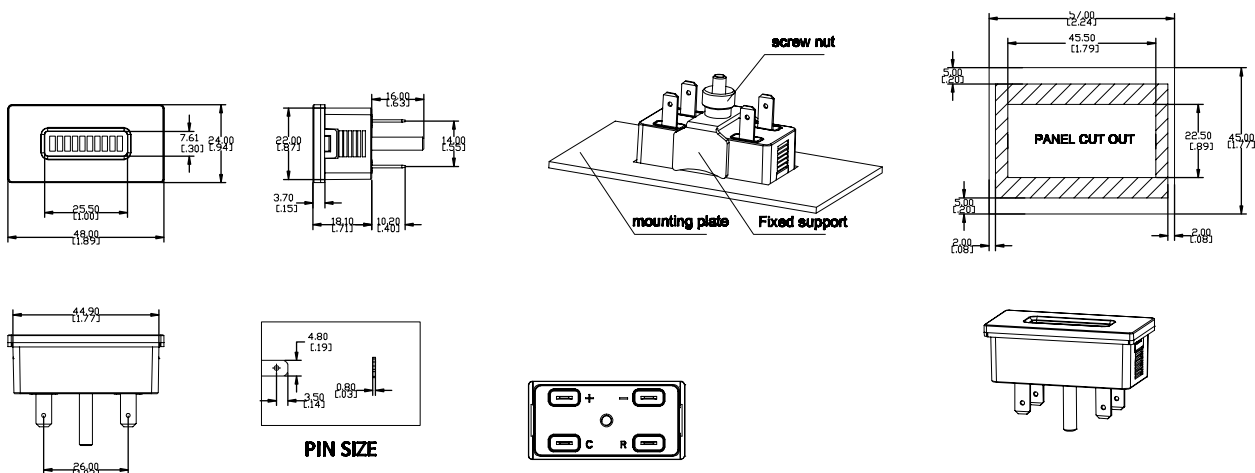

Newark.com/multicomp-pro  
Farnell.com/multicomp-pro  
sg.element14.com/b/multicomp-pro

multicomp **PRO**

# Battery Indicator

## Multi-Color

**multicomp** PRO

+	12-24V: Positive pole of battery input. connect to battery positive within DC 9-28V.
	36V: Positive pole of battery input, connect to battery positive within DC 25-45V.
	48V: Positive pole of battery input, connect to battery positive within DC 35-60V.
-	Negative pole of battery input, connect to the battery negative.
C	Key switch. Connect to battery positive.
R	Battery capacity <10%, relay out OV; Battery capacity ≥10%, relay out 5V (can customize)

Battery type (can Customize)		Battery level									
		1	2	3	4	5	6	7	8	9	10
Lead-acid	12V	10.38	10.59	10.8	11.01	11.22	11.43	11.64	11.85	12.3	>12.3
	24V	20.76	21.18	21.6	22.02	22.44	22.86	23.28	23.7	24.6	>24.6
	36V	31.14	31.77	32.4	33.03	33.66	34.29	34.92	35.55	36.9	>36.9
	48V	41.52	42.36	43.2	44.04	44.88	45.72	46.56	47.4	49.2	>49.2

### Part Number Table

Description	Part Number
Battery Indicator, 12-24V, Lead-Acid	MP011710
Battery Indicator, 36V, Lead-Acid	MP011711
Battery Indicator, 48V, Lead-Acid	MP011712

**Important Notice :** This data sheet and its contents (the "Information") belong to the members of the AVNET group of companies (the "Group") or are licensed to it. No licence is granted for the use of it other than for information purposes in connection with the products to which it relates. No licence of any intellectual property rights is granted. The Information is subject to change without notice and replaces all data sheets previously supplied. The Information supplied is believed to be accurate but the Group assumes no responsibility for its accuracy or completeness, any error in or omission from it or for any use made of it. Users of this data sheet should check for themselves the Information and the suitability of the products for their purpose and not make any assumptions based on information included or omitted. Liability for loss or damage resulting from any reliance on the Information or use of it (including liability resulting from negligence or where the Group was aware of the possibility of such loss or damage arising) is excluded. This will not operate to limit or restrict the Group's liability for death or personal injury resulting from its negligence. Multicomp Pro is the registered trademark of Premier Farnell Limited 2019.

Newark.com/multicomp-pro  
 Farnell.com/multicomp-pro  
 sg.element14.com/b/multicomp-pro

**multicomp** PRO