

# Manganese Lithium Coin Batteries (ML series): Individual Specifications

## ML2020

### ■ Dimensions(mm)

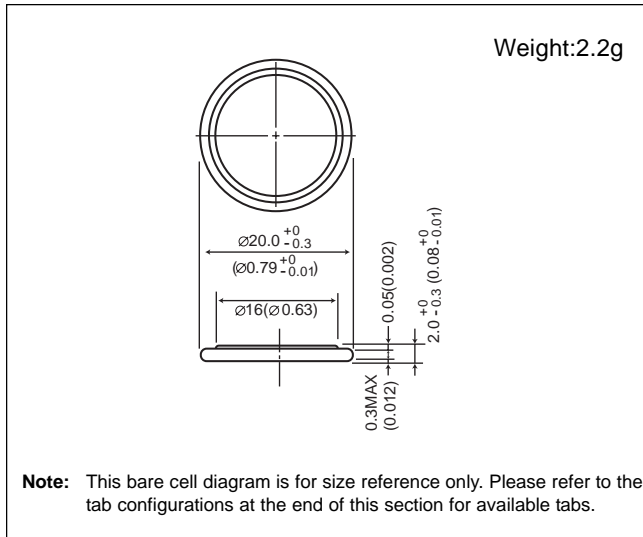

### ■ Specification

<b>Nominal voltage (V)</b>	3
<b>Nominal capacity (mAh)</b>	45
<b>Continuous standard load (mA)</b>	0.12
<b>Operating temperature (C)</b>	-20 ~ +60

### ■ Discharge characteristics

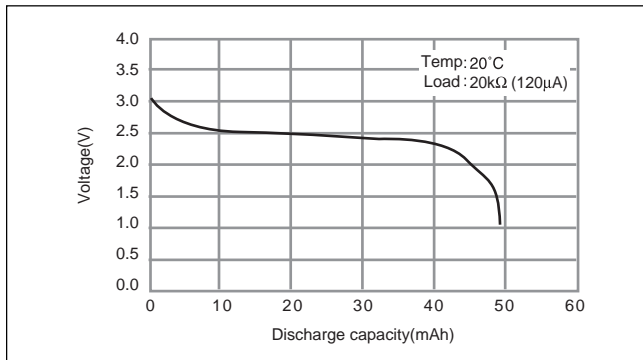

### ■ Consumption current vs. Duration time

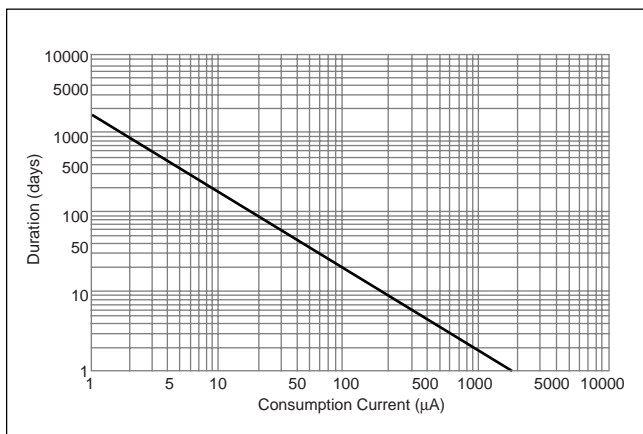

# Manganese Lithium Coin Batteries (ML series): Individual Specifications

## ML421

### □ Dimensions(mm)

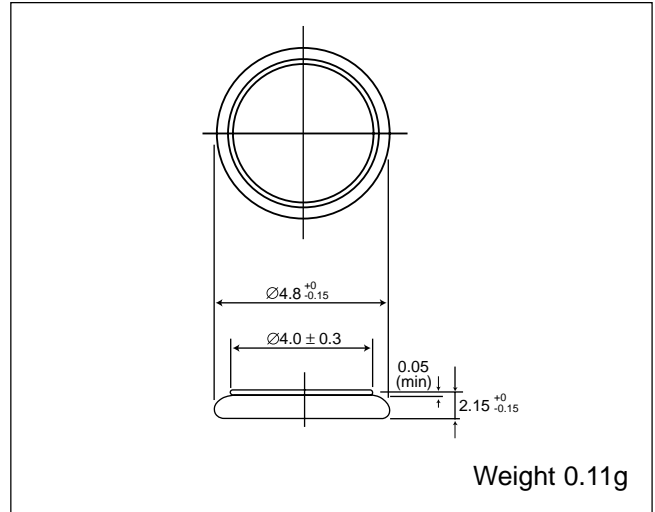

### □ Specification

<b>Nominal voltage (V)</b>	3
<b>Nominal capacity (mAh)</b>	2.3
<b>Continuous standard load (mA)</b>	0.003
<b>Operating temperature (C)</b>	-20 ~ +60

### □ Discharge characteristics

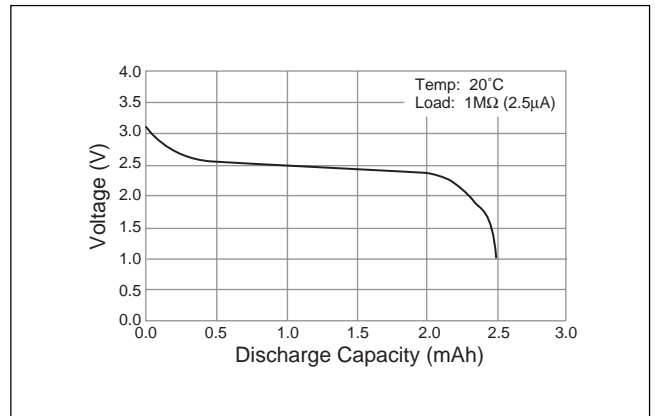

### □ Consumption current vs. Duration time

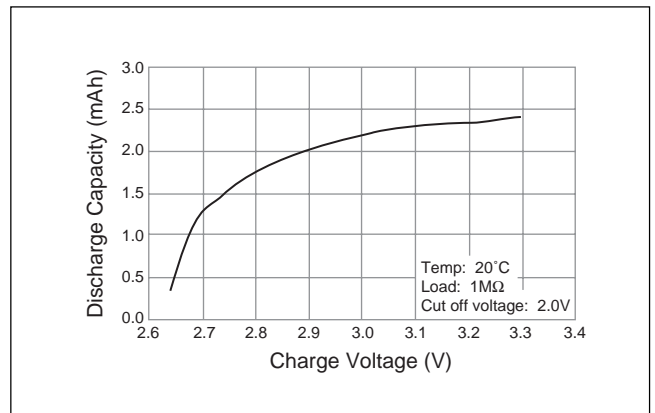

# Manganese Lithium Coin Batteries (ML series): Individual Specifications

## ML614

### □ Dimensions(mm)



### □ Specification

Nominal voltage (V)	3
Nominal capacity (mAh)	3.4
Continuous standard load (mA)	0.01
Operating temperature (C)	-20 ~ +60

### □ Discharge characteristics

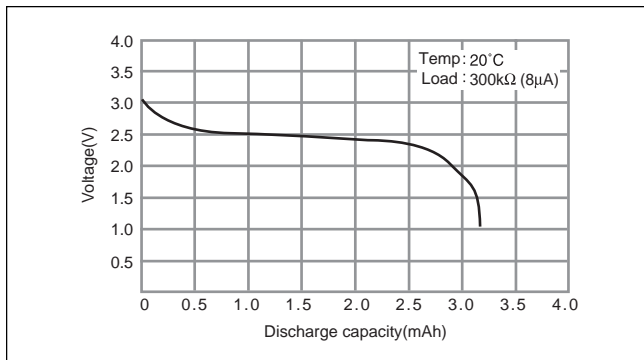

### □ Consumption current vs. Duration time

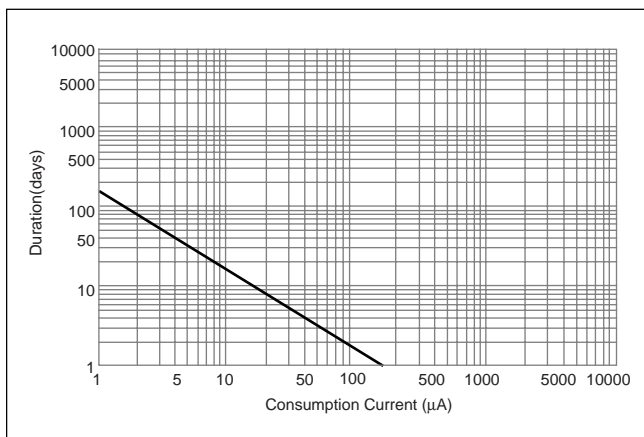

## ML621

### □ Dimensions(mm)

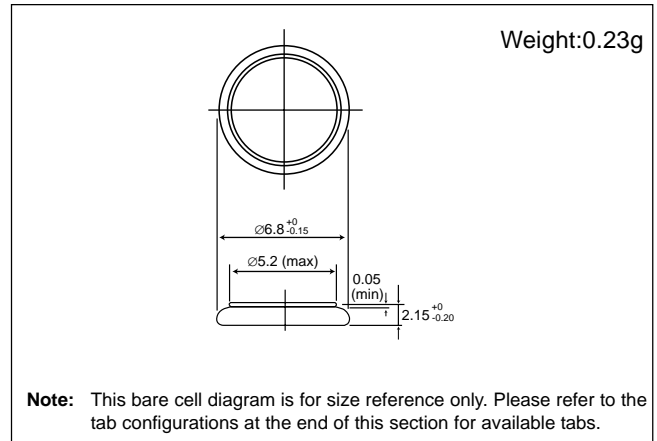

### □ Specification

Nominal voltage (V)	3
Nominal capacity (mAh)	5
Continuous standard load (mA)	0.01
Operating temperature (C)	-20 ~ +60

### □ Discharge characteristics

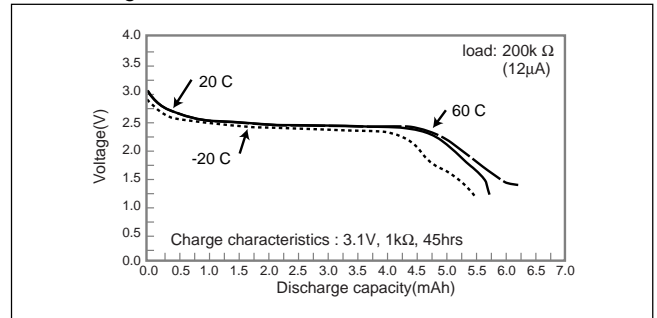

### □ Charge characteristics

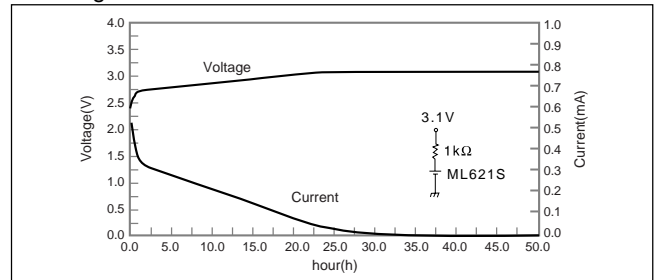

### □ Consumption current vs. Duration time

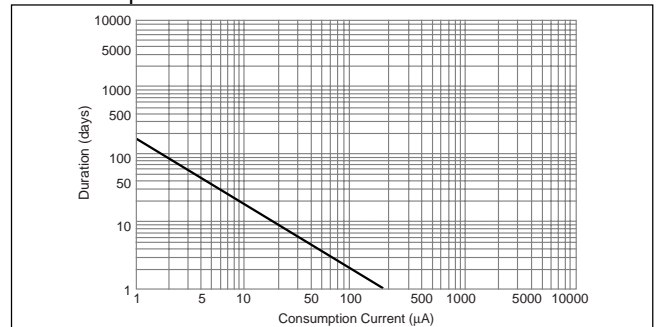

# Manganese Lithium Coin Batteries (ML series): Individual Specifications

## ML920

### □ Dimensions(mm)

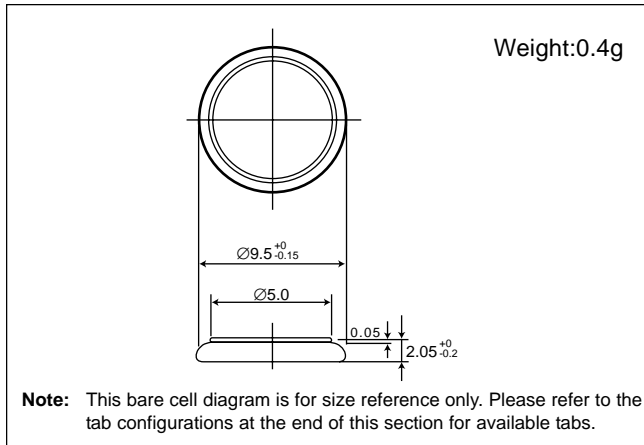

### □ Specification

Nominal voltage (V)	3
Nominal capacity (mAh)	11.0
Continuous standard load (mA)	0.03
Operating temperature (C)	-20 ~ +60

### □ Discharge characteristics

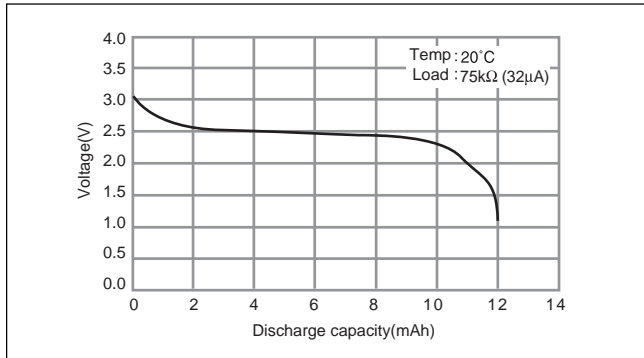

### □ Consumption current vs. Duration time

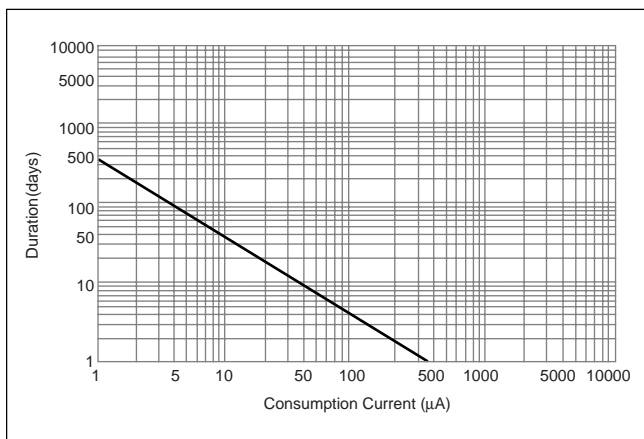

## ML1220

### □ Dimensions(mm)

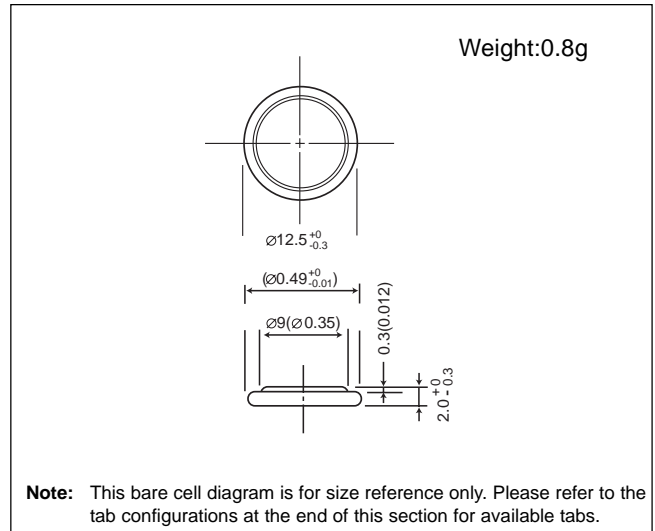

### □ Specification

Nominal voltage (V)	3
Nominal capacity (mAh)	17.0
Continuous standard load (mA)	0.03
Operating temperature (C)	-20 ~ +60

### □ Discharge characteristics

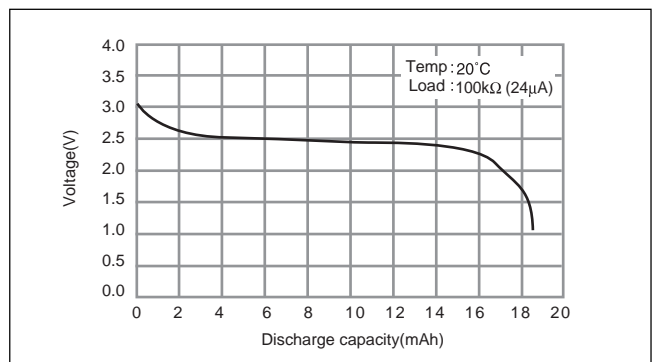

### □ Consumption current vs. Duration time

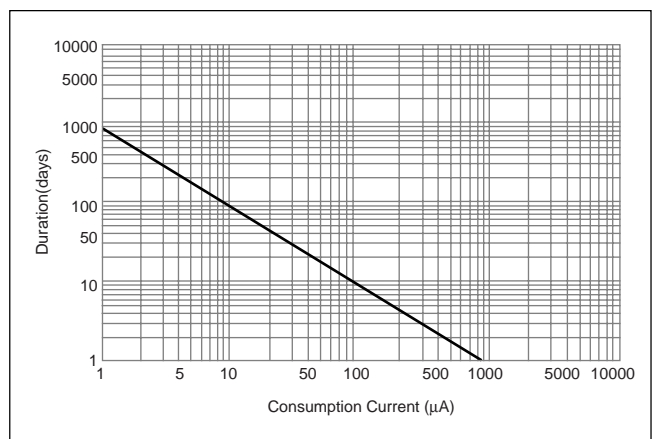

# Product Information Sheet

## Panasonic Batteries

Panasonic Industrial Company  
A Division Panasonic Corporation of North America  
5201 Tollview Drive, 1F-3  
Rolling Meadows, IL 60008  
Toll Free: 877-726-2228  
Fax: 847-637-4660  
Internet: [www.panasonic.com/industrial/batteries.oem](http://www.panasonic.com/industrial/batteries.oem)  
e-mail: [ombatteries@panasonic.com](mailto:ombatteries@panasonic.com)

**Product:** Manganese Lithium (ML Type) Lithium Batteries  
**Applicable models/sizes:** All ML type

**Revision:** January 1, 2014

**The batteries referenced herein are exempt articles and are not subject to the OSHA Hazard Communication Standard requirement. This sheet is provided as a service to our customers.**

## MSDS

Material Safety Data Sheets (MSDS) are a sub-requirement of the Occupational Safety and Health Administration (OSHA) Hazard Communication Standard, 29 CFR Subpart 1910.1200. This Hazard Communication Standard does not apply to various subcategories including anything defined by OSHA as an "article". OSHA has defined "article" as a manufactured item other than a fluid or particle; (i) which is formed to a specific shape or design during manufacture; (ii) which has end use function(s) dependent in whole or in part upon its shape or design during end use; and (iii) which under normal conditions of use does not release more than very small quantities, e.g. minute or trace amounts of a hazardous chemical, and does not pose a physical hazard or health risk to employees.

*Because all of our batteries are defined as "articles", they are exempt from the requirements of the Hazard Communication Standard; hence a MSDS is not required.*

## DISPOSAL

These batteries contain so little lithium that they are never defined by the federal government as a reactive hazardous waste and are safe for disposal in the normal municipal waste stream..

## TRANSPORTATION

All Panasonic lithium batteries are not subject to the requirements of the Department of Transportation (DOT) Subchapter C, Hazardous Materials Regulations if shipped in compliance with 49 CFR 173.185 and Special Provision 188.

Effective January 1, 2014 all Panasonic lithium batteries can be shipped by air in accordance with International Civil Aviation Organization (ICAO), 2013-2014 edition, Section II or Section 1B, International Air Transport Association (IATA) 55th edition, Section II or Section 1B Packing Instructions (PI) 968 (Batteries), PI 969 (Batteries, packed with equipment) and PI 970 (Batteries, contained in equipment) as appropriate

All Panasonic lithium batteries are regulated by the International Maritime Organization (IMO), 2012 edition, 36<sup>th</sup> amendment, under Special Provisions 188 and 230.

All Panasonic lithium cells are tested and comply with the UN Model Regulations, Manual of Test and Criteria, Part III, subsection 38.3.

If you build any of our lithium cells into a battery pack, you must also assure that they are tested in accordance with the UN Model Regulations, Manual of Test and Criteria. Part III, subsection 38.3, 5<sup>th</sup> revised edition, Amendment 1.

The DOT requires that the outside of each package that contains lithium metal batteries, regardless of size or number of batteries, be labeled with the following statement: "**LITHIUM METAL BATTERIES- FORBIDDEN FOR TRANSPORT ABOARD PASSENGER AIRCRAFT**". The labeling requirement covers shipments via highway, rail, vessel or cargo-only aircraft and covers all shipments inside, into or out of the US. The label must be in contrasting color and the letters must be 12 mm (0.5 in) in height for packages weighing more than 30 Kg and 6 mm (0.25 in) in height for packages weighing less than 30 Kg.

---

**Notice:** The information and recommendations set forth are made in good faith and are believed to be accurate at the date of preparation. Panasonic Industrial Company makes no warranty expressed or implied.

---

## **First Aid**

If you get electrolyte in your eyes, flush with water for 15 minutes without rubbing and immediately contact a physician. If you get electrolyte on your skin wash the area immediately with soap and water. If irritation continues, contact a physician. If a battery is ingested, call the National Capital Poison Center (NCPC) at 202-625-3333 (Collect) or your local poison center immediately. Lithium coin batteries lodged in the esophagus should be removed immediately. Leakage, chemical burns and perforation can occur within hours of ingestion.

## **General Recommendations**

CAUTION: Risk of fire, explosion and burns. Do not recharge, crush, heat above 212<sup>o</sup>F (100<sup>o</sup>C) or incinerate.

## **Fire Safety**

In case of fire, you can use a Class "D" fire extinguisher or other smothering agent such as Lith-X, copper powder or dry sand. If you use water, use enough to smother the fire. Using an insufficient amount of water will only make the fire worse. Cooling the exterior of the batteries will help prevent rupturing. Burning of these batteries will generate toxic and corrosive lithium hydroxide fumes. Fire fighters should use self-contained breathing apparatus. Detailed information on fighting a lithium metal battery fire can be found in Guide 138 (Substances – Water – Reactive) of the US DOT Emergency Response Guide.