

Description

The compact and flexible all-in-one solution REX consists of several perfectly matched components. It comprises the EM12D-T / EM12-T supply module for the plus and minus potential via a single or double channel REX12D-T electronic circuit protector which can be mounted side by side in any number and the PM12-T potential extension module for plus and minus multiplication.

The requirements regarding modern machinery and equipment are constantly growing. System transparency, remote maintenance and remote access are getting more and more important in international competition. Early notification in the event of any disturbances and a fast response to current problems will increase system availability, save costs and improve the overall stability of the production process.

E-T-A provides the ideal solution for machine and panel builders with the intelligent REX12D protection system and the EM12D interface module. The system combines the well-proven quality of DC 24 V overcurrent protection with the communication options of the IO link and Modbus RTU system. It allows complete transparency of the DC24V power supply and provides all necessary information for a reliable production process in this plant sector.

The 12.5 mm wide modules feature a modular design with push-in technology for wiring with press release buttons and allow no-tool time-saving and maintenance-free wiring.

Features

- Control, diagnosis and monitoring via IO link and Modbus RTU
- Combination of supply modules, overcurrent protection and power distribution
- Selective load protection by means of electronic trip curve
- No accessories required for connecting the components
- Width per channel only 6.25 mm (2-channel)
- Fixed and adjustable current ratings 1 A-10 A
- Integral fail-safe element, adjusted to max. current rating
- Switching capacitive loads up to 20,000 µF
- Manual ON/OFF/reset momentary switch
- Connection via push-in terminals including press release buttons

Approvals



Compliances



And what is more: no additional accessories are required when connecting the individual components electrically and mechanically. This helps save time and money!

US patent number: US 9,899,807 B2

Benefits

- Increases machine availability through high transparency and remote diagnosis
- Saves cost – no further accessories required
- Saves 50 % time through innovative and flexible mounting and connection technology
- Saves space – with a width of only 12.5 mm per channel
- Provides flexibility through ease of mounting, disassembly and modular design
- Reduces storage costs because only one product is required for all current ratings

Data sheet

The current data sheet is available on our website: www.e-t-a.de/e751

Technical data ($T_{amb} = +23\text{ }^{\circ}\text{C}$, $U_B = \text{DC } 24\text{ V}$)

REX12D-Txx-xxx circuit protectors

REX12D-TA1-100-DC24V-xA	1-channel
REX12D-TA2-100-DC24V-xA/xA	2-channel
REX12D-TE2-100-DC24V-xA-xA	2-channel

The REX12D-TAx is operated in the COM mode with EM12D-T. The REX12D-TE2 can be operated both with EM12D-T or EM12-T. The operating mode EM12D-T (COM mode) or EM12-T (standard) is recognised automatically. The following data exclusively refer to the COM mode.

Operating voltage U_B	DC 24 V (18...30 V)
Closed current I_0	
REX12D-TA1 1-channel	in ON condition: typically 7 mA
REX12D-TA2 2-channel	in ON condition: typically 10 mA
REX12D-TE2 1A-4A 2-channel	in ON condition: typically 9 mA
REX12D-TE2 1A-10A 2-channel	in ON condition: typically 12 mA
Reverse polarity protection	Yes
Power failure buffering time	up to 10 ms
Rated current I_N	ratings:
REX12D-TA1	8 A, 10 A
REX12D-TA2	1 A/1 A, 2 A/2 A, 3 A/3 A, 4 A/4 A, 6 A/6 A
REX12D-TE2	1 A-4 A, 1 A-10 A condition upon delivery: max. current rating
Visual status indication of operating condition by multicoloured LED:	green: - load circuit connected green/orange blinking: - load current warning limit reached 50 % - 100 % orange: - overload or short circuit until disconnection - circuit protector was switched off by the superordinate control unit LED is permanently orange red: - after disconnection due to overload or short circuit - after undervoltage release of operating voltage in ON condition with autoreset OFF Device was switched off via ON/OFF momentary switch, or due to lacking operating voltage or faulty initialisation of the circuit protector

Load circuit

Load output	power MOSFET switching output (plus switching)
Load current - warning limit (I_{WLimit})	typically $0.5 - 1.0 \times I_N$ (parameterisable)
hysteresis	typically 5 %
Overload current disconnection (I_{OL}) with trip times (t_{OL})	typically $I_{OL}: I_N \times 1.05$ $t_{OL}: 3s$ typically $I_{OL}: I_N \times 1.35$ $t_{OL}: 0.5, 5s$ typically $I_{OL}: I_N \times 2.00$ $t_{OL}: 0.1s$ typically $I_{OL}: I_N \times 2.50$ $t_{OL}: 0.012s$
short circuit trip time (t_{SC})	typically at short circuit (I_{SC}) $t_{SC}: 0.002s^2$ see time/current characteristic
Influence of ambient temperature on overload disconnection and load current - warning limit	see temperature factor table
Continuous Current IC	typically $0.8 \times I_N$ (Fail Safe Element is protected by REX12)

2) depending on power source

Technical data ($T_{amb} = +23\text{ }^{\circ}\text{C}$, $U_B = \text{DC } 24\text{ V}$)

Fail-safe element (integral blade fuse adjusted to related current rating I_N)	$I_N: 1\text{ A}/1\text{ A (CL2)}$ fail-safe $I_N: 1\text{ A} / 1\text{ A}$ $I_N: 2\text{ A}/2\text{ A (CL2)}$ fail-safe $I_N: 2\text{ A} / 2\text{ A}$ $I_N: 3\text{ A}/3\text{ A}$ fail-safe $I_N: 3.15\text{ A} / 3.15\text{ A}$ $I_N: 3A/3A-CL2$ fail-safe $I_N: 4\text{ A} / 4\text{ A}$ $I_N: 4\text{ A}/4\text{ A}$ fail-safe $I_N: 4\text{ A} / 4\text{ A}$ $I_N: 4A/4A-CL2$ fail-safe $I_N: 4\text{ A} / 4\text{ A}$ $I_N: 6\text{ A}/6\text{ A}$ fail-safe $I_N: 6.3\text{ A} / 6.3\text{ A}$ $I_N: 8\text{ A}$ fail-safe $I_N: 8\text{ A}$ $I_N: 10\text{ A}$ fail-safe $I_N: 10\text{ A}$ $I_N: 1\text{ A-}4\text{ A-CL2}$ fail-safe $I_N: 4\text{ A}$ $I_N: 1\text{ A-}10\text{ A}$ fail-safe $I_N: 16\text{ A}$
---	---

Voltage drop in load circuit at I_N and at I_N 70% REX12D-TAx between LINE+ and LOAD+

$I_N: 1\text{ A (CL2)}$	typically 180 mV	$I_N: 70\%$	typically 125 mV
$I_N: 2\text{ A (CL2)}$	typically 110 mV	$I_N: 70\%$	typically 80 mV
$I_N: 3\text{ A}$	typically 120 mV	$I_N: 70\%$	typically 85 mV
$I_N: 3\text{ A-CL2}$	typically 130 mV	$I_N: 70\%$	typically 90 mV
$I_N: 4\text{ A}$	typically 115 mV	$I_N: 70\%$	typically 80 mV
$I_N: 4\text{ A-CL2}$	typically 180 mV	$I_N: 70\%$	typically 120 mV
$I_N: 6\text{ A}$	typically 170 mV	$I_N: 70\%$	typically 110 mV
$I_N: 8\text{ A}$	typically 160 mV	$I_N: 70\%$	typically 105 mV
$I_N: 10\text{ A}$	typically 180 mV	$I_N: 70\%$	typically 120 mV

Voltage drop in load circuit at I_N and at I_N 70% REX12D-TEx between LINE+ and LOAD+

REX12D-TE2-100-DC24V-1A-4A-CL2

$I_N: 1A-CL2$	typically 50 mV	$I_N: 70\%$	typically 42 mV
$I_N: 2A-CL2$	typically 90 mV	$I_N: 70\%$	typically 70 mV
$I_N: 3A-CL2$	typically 135 mV	$I_N: 70\%$	typically 95 mV
$I_N: 4A-CL2$	typically 180 mV	$I_N: 70\%$	typically 120 mV

Voltage drop in load circuit at I_N and at I_N 70 % for REX12D-TEx between LINE+ and LOAD+

REX12D-TE2-100-DC24V-1A-10A

$I_N: 1\text{ A}$	typically 30 mV	$I_N: 70\%$	typically 28 mV
$I_N: 2\text{ A}$	typically 39 mV	$I_N: 70\%$	typically 34 mV
$I_N: 3\text{ A}$	typically 48 mV	$I_N: 70\%$	typically 40 mV
$I_N: 4\text{ A}$	typically 57 mV	$I_N: 70\%$	typically 46 mV
$I_N: 5\text{ A}$	typically 66 mV	$I_N: 70\%$	typically 52 mV
$I_N: 6\text{ A}$	typically 74 mV	$I_N: 70\%$	typically 59 mV
$I_N: 7\text{ A}$	typically 83 mV	$I_N: 70\%$	typically 65 mV
$I_N: 8\text{ A}$	typically 92 mV	$I_N: 70\%$	typically 71 mV
$I_N: 9\text{ A}$	typically 101 mV	$I_N: 70\%$	typically 77 mV
$I_N: 10\text{ A}$	typically 110 mV	$I_N: 70\%$	typically 83 mV

Operating voltage monitoring with regard to low voltage	OFF at typically $U_B < 16.0\text{ V}$ ON at typically $U_B > 19\text{ V}$ with automatic ON and OFF switching
---	--

ON delay - with power ON	channel 1: typically 100 ms (REX12D-TAx) channel 2: typically 200 ms (REX12D-TAx) channel 1: typically 1,500 ms (REX12D-TE2, depending on the slot) channel 2: typically 1,600 ms (REX12D-TE2, depending on the slot)
--------------------------	--

- when switching on by means ON/OFF button	channel 1: typically 5 ms channel 2: typically 100 ms
- after undervoltage	channel 1: typically 5 ms channel 2: typically 5 ms

Disconnection of load circuit	- manually on the device with the ON/OFF momentary switch - remote control via the superordinate control unit - after an overload / short circuit disconnection with storage (no automatic reset) - temporarily at undervoltage - at no operating voltage
-------------------------------	---

Technical data ($T_{amb} = +23\text{ °C}$, $U_B = \text{DC } 24\text{ V}$)

Switch on of load circuit	The circuit protector can be switched on by the superordinate control unit or otherwise directly on the device. These two options are linked with AND. Switch-on is only possible if switched on from both positions. If the circuit protector was switched off either by the control unit or by the momentary switch directly on the device, switch-on has to be effected also from the corresponding position.
- momentary switch ON/OFF	
- apply operating voltage	For switch-on the device has to be supplied with operating voltage. The device re-starts with the last stored condition.
Enquire adjusted current rating with REX12D-TE2	Enquiry of currently adjusted current rating is, independent of the operating mode (COM or standard), possible for each channel directly on the REX12D-TE2 Enquiry mode is started by pushing the button between ≥ 2 seconds and < 5 seconds. After releasing the button, the LED is RED for 333 ms to indicate start of enquiry. Afterwards, the LED flashes ORANGE in a puls/break ratio of 1/2 with a frequency of 1 Hz to indicate the adjusted current value. When the adjusted current rating is reached, signalling re-starts after the RED LED re-lights for 333 ms. The enquiry mode is left after the adjusted current rating was signalled 5 times or by pressing the button. Visual indication will now show again the current operating condition. The enquiry mode is possible in all operating conditions (ON, OFF, UNDERVOLTAGE and TRIPPED).

Adjustment of the current rating of the REX12D-TE2 is possible in the COM mode via the corresponding communication interface.

Go to video **Mounting and operation:**



Reset function	a blocked load output (blocked by overload / short circuit) can be reset by the ON/OFF momentary switch or by the superordinate control unit.
Leakage current in load circuit in OFF condition	typically $< 1\text{ mA}$
Capacitive loads	up to 20,000 μF : depending on: cable attenuation, power supply used, load current and current rating
Free-wheeling diode	external free-wheeling circuit at inductive load (rating according to load)
Parallel connection of several load outputs	not allowed
Terminals LOAD+	
Push-in terminal PT 2.5	0.14 mm ² ... 2.5 mm ² , flexible AWG24 – AWG14 rigid

Technical data ($T_{amb} = +23\text{ °C}$, $U_B = \text{DC } 24\text{ V}$)

Stripping length	8 mm...10 mm
Dimensions (w x h x d)	12.5 x 80 x 98.5 mm
Mass	REX12D-TA1-xxx 1-channel approx. 58 g REX12D-Tx2-xxx 2-channel approx. 62 g
General data REX / EM / PM	
Housing material	moulded
Mounting	symmetrical rail to EN 60715-35x7.5
Ambient temperature	-25 °C...+60 °C (without condensation, cf. EN 60204-1)
Storage temperature	-40 °C ... +70 °C
Mounting temperature	+5° ... +60 °C
Humidity	96 hrs / 95 % RH/40 °C to IEC 60068-2-78-Cab climate class 3K3 to EN 60721
Altitude	2,000 m above sea level 3,000 m above sea level up to +55 °C 4,000 m above sea level up to +50 °C
Operation pressure	4 bar above atmospheric pressure
Corrosion only PM and EM accessories	96 hrs. in 5 % salt mist to IEC 60068-2-11 test Ka
Vibration	5 g test to IEC 60068-2-6, test Fc
Degree of protection operating area REX12	IEC 60529, DIN VDE 0470 IP30
terminal area EM, PM:	IP20
EMC requirements (EMC directive, CE logo)	noise emission EN 61000-6-3 susceptibility EN 61000-6-2
Insulation co-ordination (IEC 60934)	0.5 kV / pollution degree 2
Dielectric strength	max. DC 30 V (load circuit)
Insulation resistance (OFF condition)	n/a, only electronic disconnection
Conformity	CE marking

Notes

- The intelligent EM12D-T supply module is only meant for use with extra-low voltage (DC 24 V).
- Connection to a higher or not reliably disconnected voltage can cause hazardous conditions or damages.
- Only the intended circuit protectors must be used.
- The technical data of the circuit protectors used have to be observed.
- The entire power distribution system must only be installed by qualified personnel.
- Only after expert installation must the device be supplied with power.
- After tripping of the circuit protector and before reset, the cause of the failure (short circuit or overload) must be remedied..
- The national standards (e.g. for Germany DIN VDE 0100) have to be observed for installation and selection of feed and return cables.
- For convenient adjustment and configuration by means of projecting software a master data file (GSDML file) will be made available for downloading on the E-T-A homepage. Please observe separate user manual of the EM12D-T.

Approvals and standards

Approval authority	Standard	UL file no.	Voltage rating	Current rating range
UL	UL 2367, UL 1310 NEC Class2	E306740	DC 24 V	1...10 A, 1 A, 2 A, 3 A, 4 A, 1 A...4 A
UL	UL 508 listed, CSA C22.2 No. 14	E492388	DC 24 V	1 A...10 A

PM and EM – accessories approvals see technical data of accessories

Ordering number code

Type		REX12D intelligent electronic circuit protector with PT connection technology	
Mounting method		T rail mounting	
Design		A 1 load output terminal per channel, fixed current ratings xA or xA/xA	
Design		E 1 load output terminal per channel, variable current ratings xA/xA, adjustable standard and COM mode	
Number of channels		1 1 channel	
Number of channels		2 2 channels	
Version		1 without physical isolation	
Signal input		0 without signal input	
Signal output		0 without signal output	
Operating voltage		DC 24 V voltage rating DC 24 V	
Current rating		8 A (only 1 channel)	
Current rating		10 A (only 1 channel)	
Current rating		1 A / 1 A (only 2 channels, Class2)	
Current rating		2 A / 2 A (only 2 channels, Class2)	
Current rating		3 A/3 A (only 2 channels)	
Current rating		4 A/4 A (only 2 channels)	
Current rating		6 A/6 A (only 2 channels)	
Current rating		1 A - 4 A (nonly 2 channels)	
Current rating		1 A - 10 A (only 2 channels)	
Approval		CL2 Class2 only 3 A, 4 A variants and 1 A - 4 A variants	
REX12D-T	A	1 - 1	0 0 - DC24V - 10A example 1 channel
REX12D-T	A	2 - 1	0 0 - DC24V - 4A/4A-CL2 example 2 channels
REX12D-T	E	2 - 1	0 0 - DC24V - 1 A-10 A example variable current ratings

Overview of ordering number codes

Supply module	EM12D-TIO-000-DC24V-40A EM12D-TMB-000-DC24V-40A
Circuit protectors: 1-channel	REX12D-TA1-100-DC24V-8A REX12D-TA1-100-DC24V-10A
Protection modules: 2-channel	REX12D-TA2-100-DC24V-1A/1A (Class2) REX12D-TA2-100-DC24V-2A/2A (Class2) REX12D-TA2-100-DC24V-3A/3A REX12D-TA2-100-DC24V-3A/3A-CL2 (Class2) REX12D-TA2-100-DC24V-4A/4A REX12D-TA2-100-DC24V-4A/4A-CL2 (Class2) REX12D-TA2-100-DC24V-6A/6A
Protection modules: 2-channel, adjustable	REX12D-TE2-100-DC24V-1A-4A-CL2 (Class2) REX12D-TE2-100-DC24V-1A-10A
Accessories	
Supply modules	EM12-T00-100-LINE-40A EM12-T00-200-LINE-40A EM12-T00-000-GND-40A EM12-T00-300-GND-40A
Potential modules	PM12-T01-00-LOAD-20A PM12-T02-00-LOAD-20A PM12-T03-00-GND-20A

Dimensions with connection diagram: REX12D-Txx-xxx circuit protectors

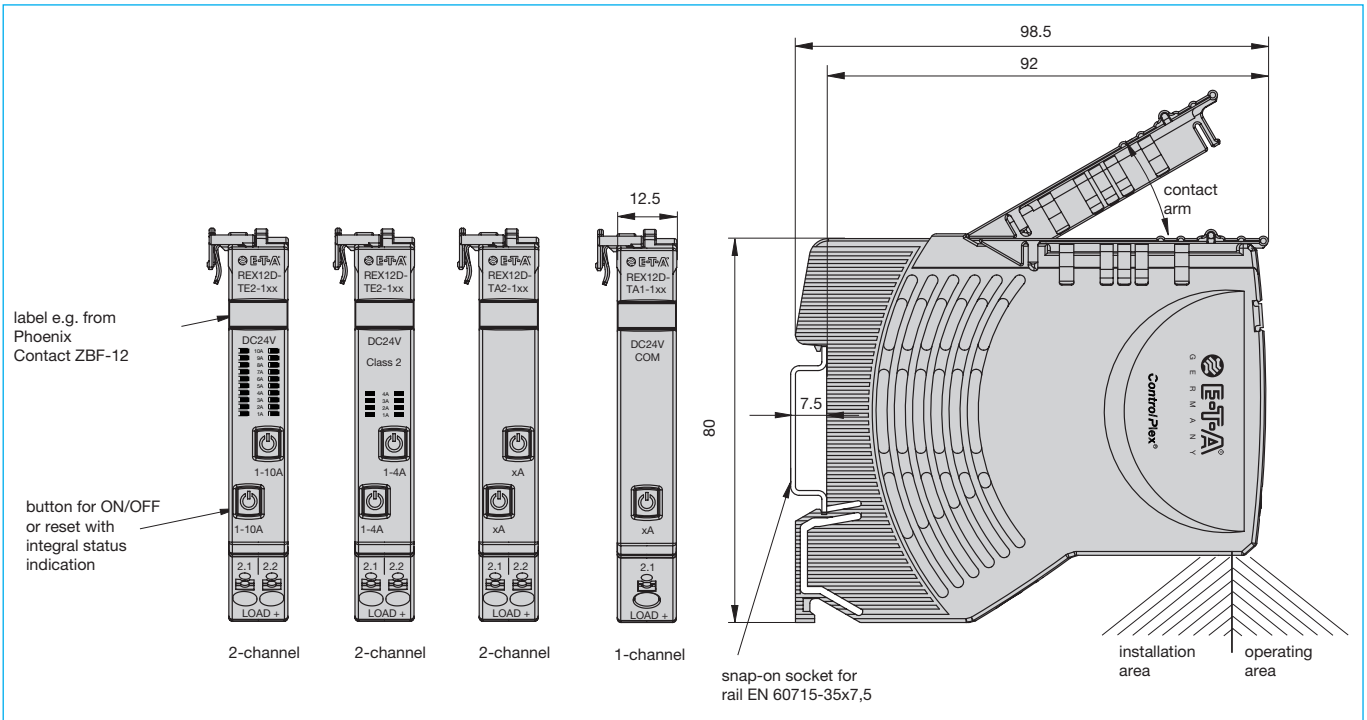

Time/current characteristic ($T_{amb} = +23\text{ °C}$, $U_B = DC - 24\text{ V}$)

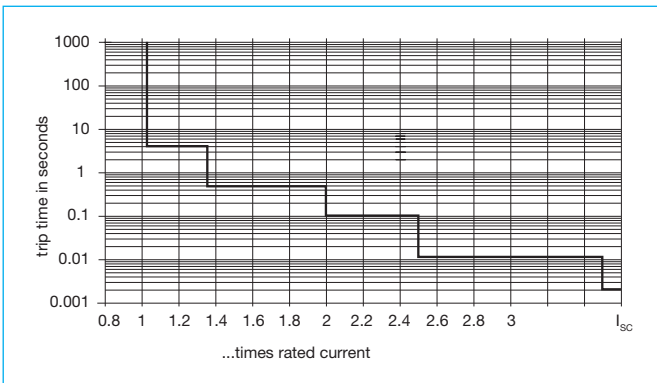

Basic trip curve and schematic diagram REX12

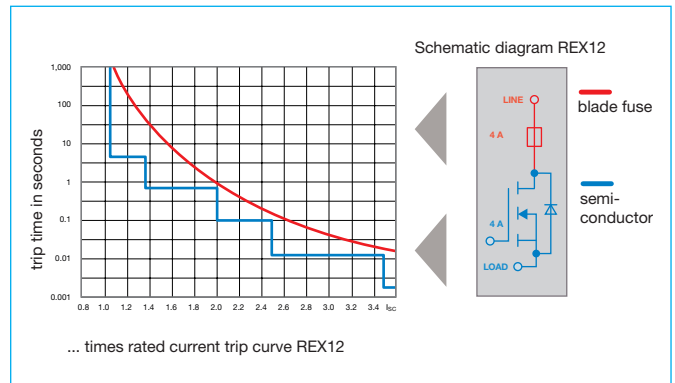

Temperature factor / continuous duty

The time/current characteristic depends on the ambient temperature. In order to determine the max. load current, please multiply the current rating with the temperature factor and consider the factor for side-by-side mounting.

Temperature factor table:

ambient temperature [°C]	0	10	23	40	50	60
temperature factor	1	1	1	0.95	0.90	0.85

Note:

When mounted side-by-side, the devices can carry max. 80 % of their rated load or a different rating has to be selected (see Technical Information on www.e-t-a.de/ti_d)

With high temperatures, the load current warning threshold "warn limit typically $0.5 \dots 1 \times I_N$ " will be reduced in accordance with the temperature factor.

Selection of current rating of the circuit protector \leq rating of power supply.

Mounting position REX... preferred mounting position horizontal

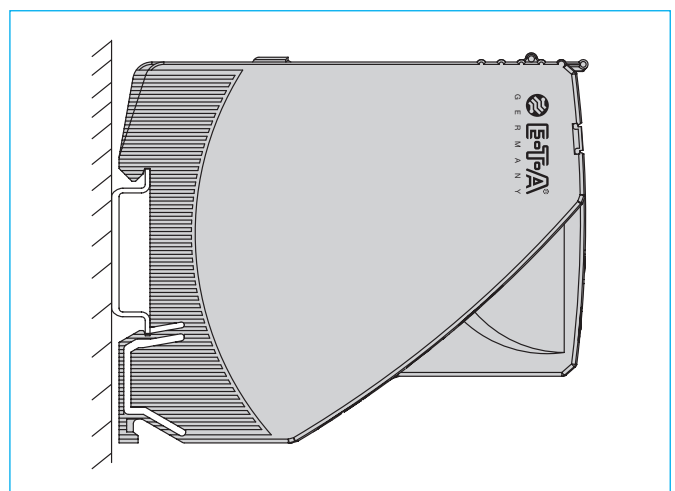

Description – EM12D-Txx supply module

The EM12D-T supply module receives the DC 24 V supply voltage, e.g. from a switched mode power supply, and distributes it to the installed intelligent circuit protectors via the integral connector arm of the REX12D-T. The communication interface of the EM12D-T, which is designed as an IO link/Modbus RTU device, allows a great number of diagnosis and control commands to a superordinate IO link/Modbus RTU master of the control level.

Technical data (T_{amb} = +23 °C, U_B = DC 24 V)

Operating voltage U _B	DC 24 V (18...30 V)
Operating current I _B	max. 40 A
Reverse polarity protection	yes
Quiescent current I ₀	typically 20 mA
Insulation co-ordination	0.5 kV / pollution degree 2
Power failure buffering time	up 10ms
Screw terminals	LINE+
Push-in terminal PT 10	0.5 mm ² ... 10 mm ² , flexible AWG24 – AWG8 rigid
stripping length	18 mm
Screw terminals	0 V
Push-in terminal PT 2.5	0.14 mm ² ... 2.5 mm ² , flexible AWG24 – AWG14 rigid
stripping length	8 mm ... 10 mm
Dimensions (w x h x d)	12.5 x 80 x 98 mm
Mass	approx. 56 g
Modules to be mounted side-by-side	
REX12D-TA1 1-channel	
REX12D-TA2 2-channel	
REX12D-TE2 2-channel	max.16 channels
Visual status indication of operating condition / via multicoloured LED:	green: faultless operation communication to IO link/ Modbus master available

green	faultless operation communication to IO link/ Modbus master available
blinking:	independent operation no communication to IO link/ Modbus master
red:	critical fault detected communication to IO link/ Modbus master not available
orange:	non-critical fault detected communication to IO link/ Modbus master available
orange blinking:	uncritical fault detected communication to IO link/ Modbus master not available
red blinking:	bootloader mode active no communication to IO link/ Modbus master

IO link connection	X81 COM interface to IO link master
terminal 1	IO link L+ DC +24V
connector 2:	IO link C/Q
connector 3:	IO link L-

When wiring and connecting to the point-to-point communication IO link, the installation and wiring regulations of the PROFIBUS-DP User Organisation (PNO) have to be observed.

Push-in terminals PT xx connector, 3-pole (plugged on) stripping length	0.25 – 0.5 mm ² 6 mm
---	------------------------------------

Technical data (T_{amb} = +23 °C, U_B = DC 24 V)

Modbus connection with Modbus Master/other devices (X81/ X82)	
X81 COM:	Connection with Modbus Master/ other Modbus devices connector 1: MB-A connector 2: MB-B connector 3: GND
X82 COM:	Connection with Modbus Master/ other Modbus devices connector 1: MB-A connector 2: MB-B connector 3: GND
terminals:	connectors, 3-pin (plugged on) cable cross section flexible with wire end ferrule (without plastic sleeve) 0.25 – 0.5 mm ² Stripping length 6 mm

IO link/Modbus – communication interface

Overview of commands:

Writing/reading of configuration (parameters)

- Current limit value (50 %...100 %)
- Current rating (1 A–10 A)

Reading of static product information

- Current rating
- Product type
- Serial number
- Hardware version
- Software version

Reading of dynamic product information / measuring values

- Error memory
- Trip counter
- Reason of last trip
- Status / event of device
- Supply voltage: ACTUAL / MIN / MAX / MEDIUM VALUE
- Load voltage ACTUAL / MIN / MAX / MEDIUM VALUE
- Load current

Control commands

- switch on/off or reset load output
- reset error memory
- reset trip counter
- set parameters to factory setting

Overview of ordering number codes

Supply module	EM12D-TIO-000-DC24V-40A (IO link) EM12D-TMB-000-DC24V-40A (Modbus-RTU)
---------------	---

Ordering number code – EM12D

Type	EM12D supply module for REX12D, with PT connection technology
Mounting method	T rail mounting
Version: Communication, interface	IO IO link MB Modbus
Additional functionality	0 without
Signal input	0 without signal input
Signal output	without signal output
Operating voltage	DC 24 V voltage rating DC 24 V
Current rating	40 A
EM12D - T IO - 0 0 0 - DC 24 V - 40 A	ordering example

7

Application example: REX assembly / disassembly on symmetrical rail

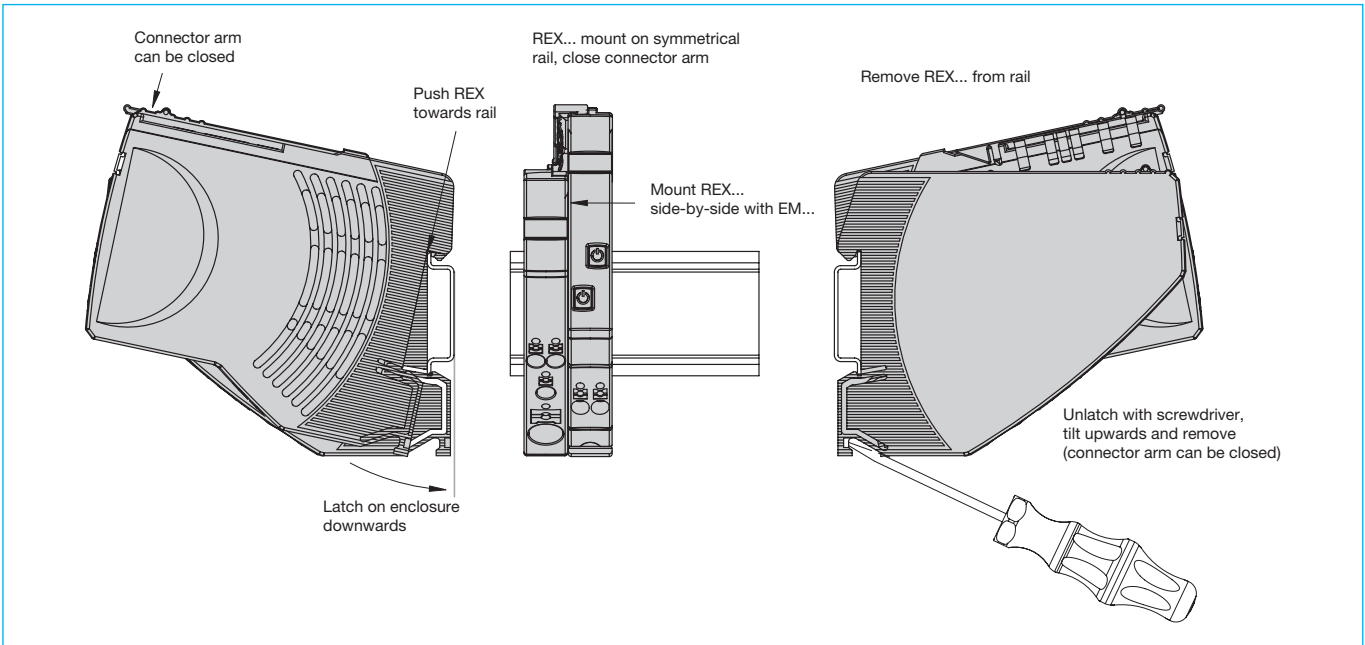

Application example: REX... Replacement or disassembly

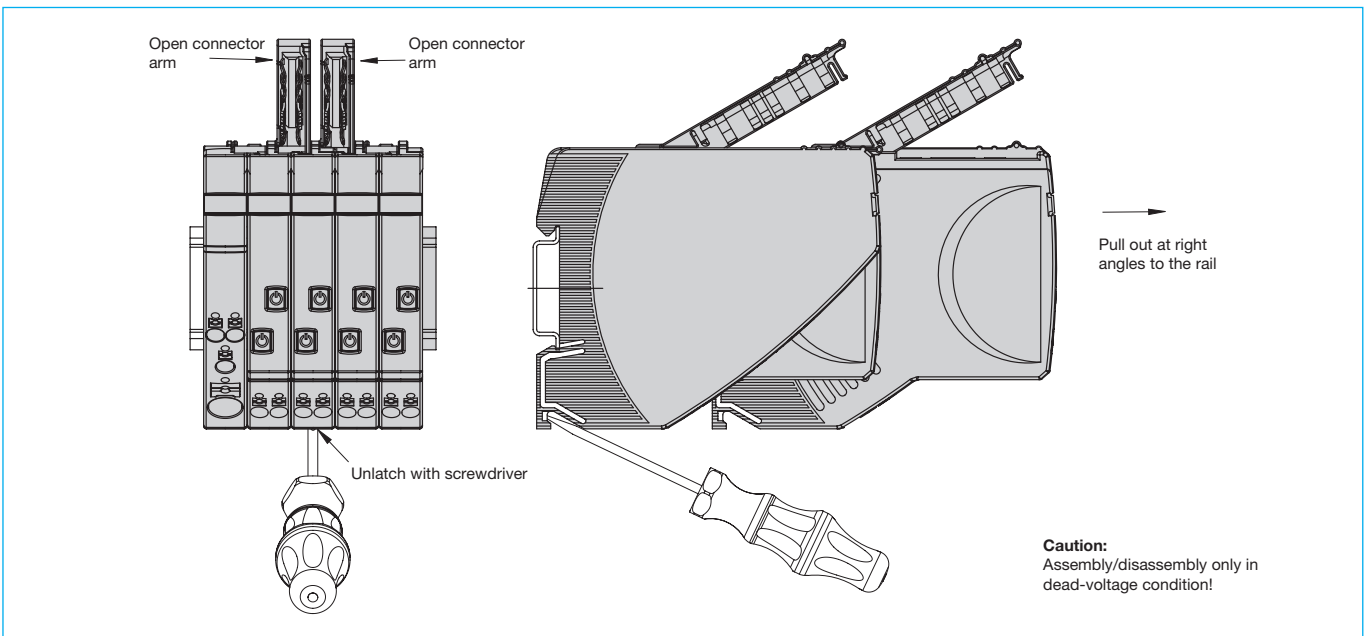

Instructions for installation

Mounting or actuation of the REX connector arm must only be effected at dead-voltage. For start-up the REX connector arm must be closed.

All information and data given on our products are accurate and reliable to the best of our knowledge, but E-T-A does not accept any responsibility for the use in applications which are not in accordance with the present specification. E-T-A reserves the right to change specifications at any time in the interest of improved design, performance and cost effectiveness. Dimensions are subject to change without notice. Please enquire for the latest dimensional drawing with tolerances if required. All dimensions, data, pictures and descriptions are for information only and are not binding. Amendments, errors and omissions excepted. Ordering codes of the products may differ from their marking.

Accessories

EM12-T00-000-GND-40A supply module left – 0V – GND

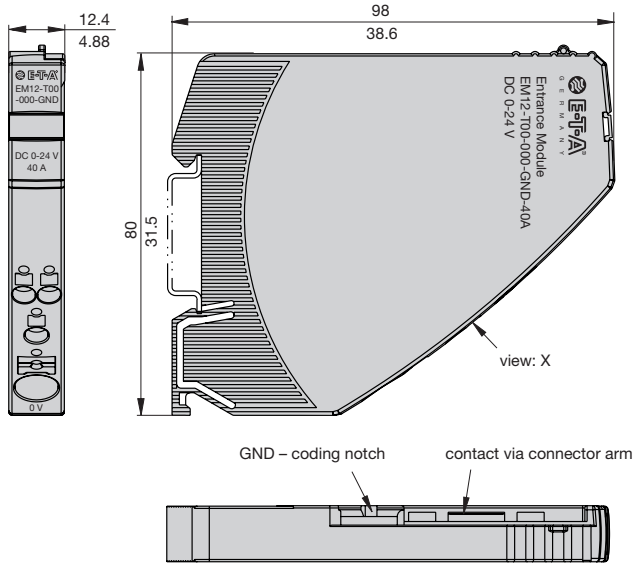

view: X

Technical data

Please observe general data of REX / EM / PM	
Operating voltage U_B	0 V – DC 24 V (0 ... 30 V)
Operating current I_B	max. load 40 A
line terminal	0 V – GND
Push-in terminal PT 10	0.5 mm ² ... 10 mm ² , flexible AWG24 – AWG8 rigid
stripping length	18 mm
Dimensions (w x h x d)	12.5 x 80 x 98 mm
Mass	approx. 40 g
Approvals	UL 1059, File # E335289

Schematic diagram

EM12-T00-000-GND-40A

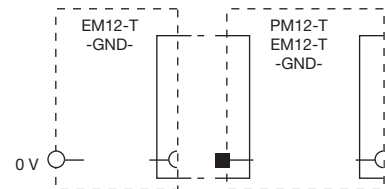

PM12-T03-00-GND-20A potential module – GND (10-way)

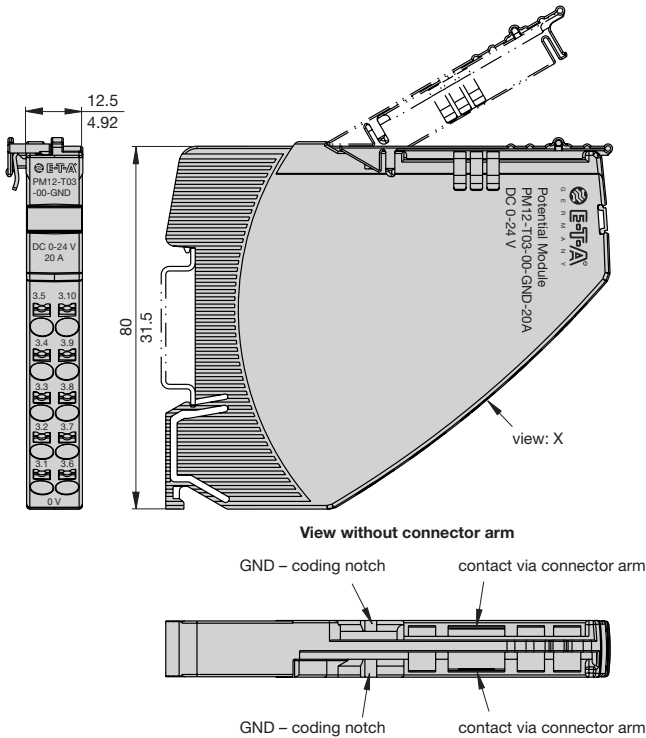

view: X

Technical data

Please observe general data of REX / EM / PM	
Operating voltage U_B	0 V – DC 24 V (0 ... 30 V)
Operating current I_B	max. load 20 A
line terminal	0 V – GND
Push-in terminal PT 2.5	0.14 mm ² ... 2.5 mm ² , flexible AWG24 – AWG14 rigid
stripping length	8 mm ... 10 mm
Dimensions (w x h x d)	12.5 x 80 x 98 mm
Mass	approx. 52 g
Approvals	UL 1059, File # E335289

Schematic diagram

PM12-T03-00-GND-20A

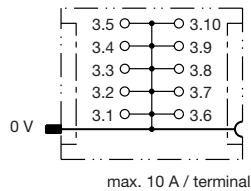

Accessories

EM12-T00-300-GND-40A supply module centre/right – 0V – GND

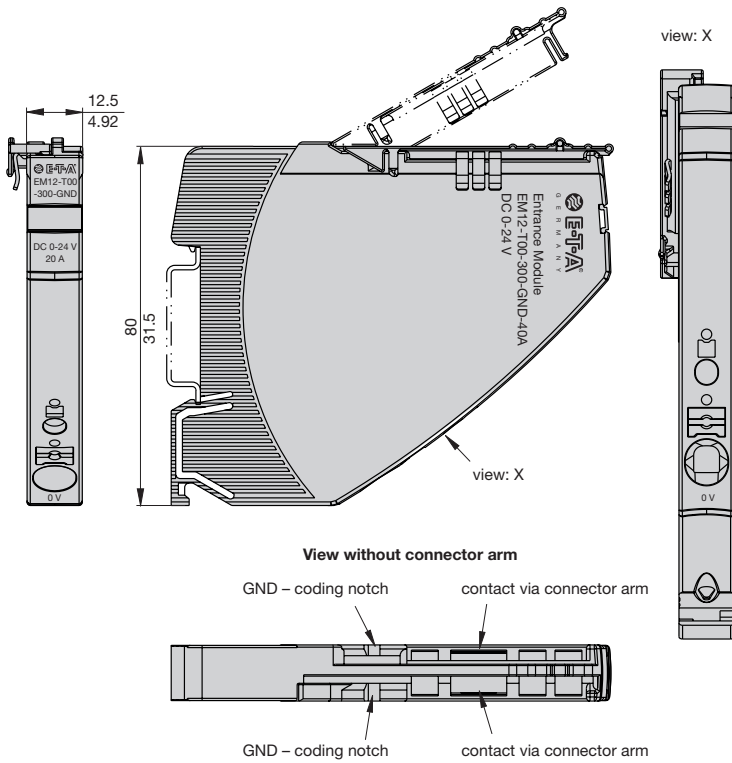

Technical data

Please observe general data of REX / EM / PM	
Operating voltage U_B	0 V – DC 24 V (0 ... 30 V)
Operating current I_B	max. load 40 A
line terminal	0 V – GND
Push-in terminal PT 10	0.5 mm ² ... 10 mm ² , flexible AWG24 – AWG8 rigid
stripping length	18 mm
Dimensions (w x h x d)	12.5 x 80 x 98 mm
Mass	approx. 45 g
Approvals	UL 1059, File # E335289

Schematic diagram

EM12-T00-300-GND-40A

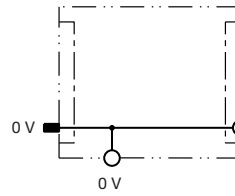

Accessories

PM12-T01-00-LOAD-20A potential module – LOAD
(10-way, 1 x supply, 9 x LOAD)

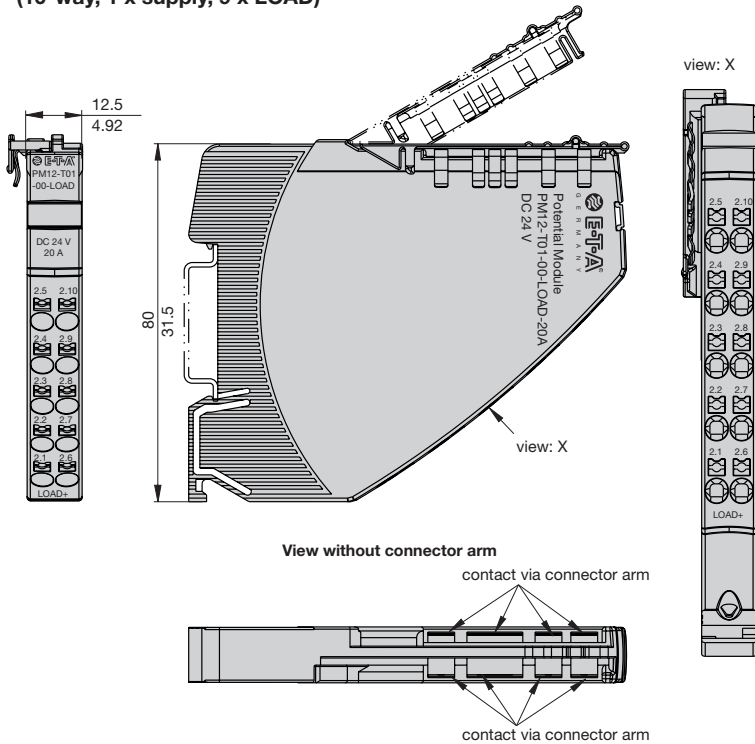

Technical data

Please observe general data of REX / EM / PM	
Operating voltage U_B	DC 24 V (18...30 V)
Operating current I_B	max. load 20 A
Insulation co-ordination	0.8 kV / pollution degree 2
Screw terminals	LOAD+
Push-in terminal PT 2.5	0.14 mm ² ... 2.5 mm ² , flexible AWG24 – AWG14 rigid
stripping length	8 mm ... 10 mm
Dimensions (w x h x d)	12.5 x 80 x 98 mm
Mass	approx. 52 g
Approvals	UL 1059, File # E335289

Schematic diagram

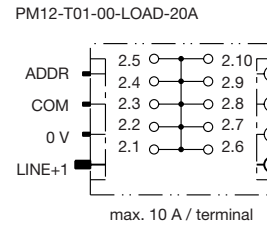

PM12-T02-00-LOAD-20A potential module – LOAD
(2 x 5-way, 1 x supply and 4 x LOAD each)

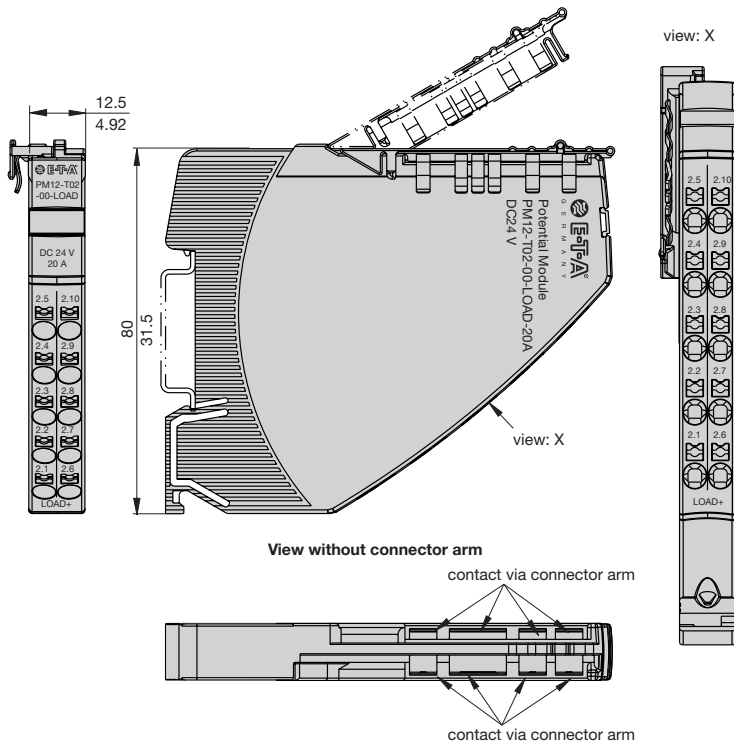

Technical data

Please observe general data of REX / EM / PM	
Operating voltage U_B	DC 24 V (18...30 V)
Operating current I_B	max. load 20 A
Insulation co-ordination	0.8 kV / pollution degree 2
Screw terminals	LOAD+
Push-in terminal PT 2.5	0.14 mm ² ... 2.5 mm ² , flexible AWG24 – AWG14 rigid
stripping length	8 mm ... 10 mm
Dimensions (w x h x d)	12.5 x 80 x 98 mm
Mass	approx. 52 g
Approvals	UL 1059, File # E335289

Schematic diagram

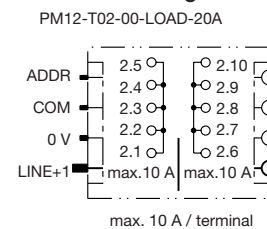

Accessories

EM12-T00-100-LINE-40A supply module centre/right – LINE, LINE connected

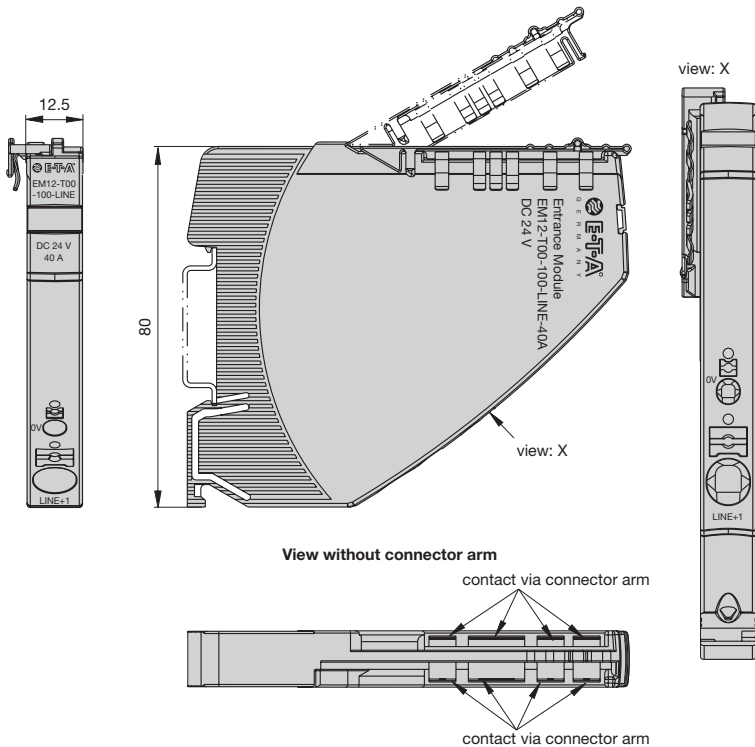

Technical data

Please observe general data of REX / EM / PM	
Operating voltage U_B	DC 24 V (18...30 V)
Operating current I_B	max. load 40 A
Insulation co-ordination	0.8 kV / pollution degree 2
Screw terminals	LINE+1
Push-in terminal PT 10	0.5 mm ² ... 10 mm ² , flexible AWG24 – AWG8 rigid
stripping length	18 mm
Screw terminals	0 V
Push-in terminal PT 2.5	0.14mm ² ... 2.5mm ² , flexible AWG24 – AWG14 rigid
stripping length	8 mm ... 10 mm
Dimensions (w x h x d)	12.5 x 80 x 98 mm
Mass	approx. 52 g
Approvals	UL 1059, File # E335289

Schematic diagram

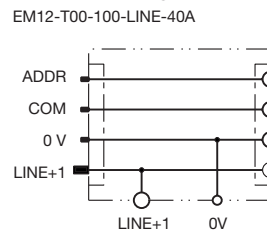

EM12-T00-200-LINE-40A supply module centre/LINE, LINE separated

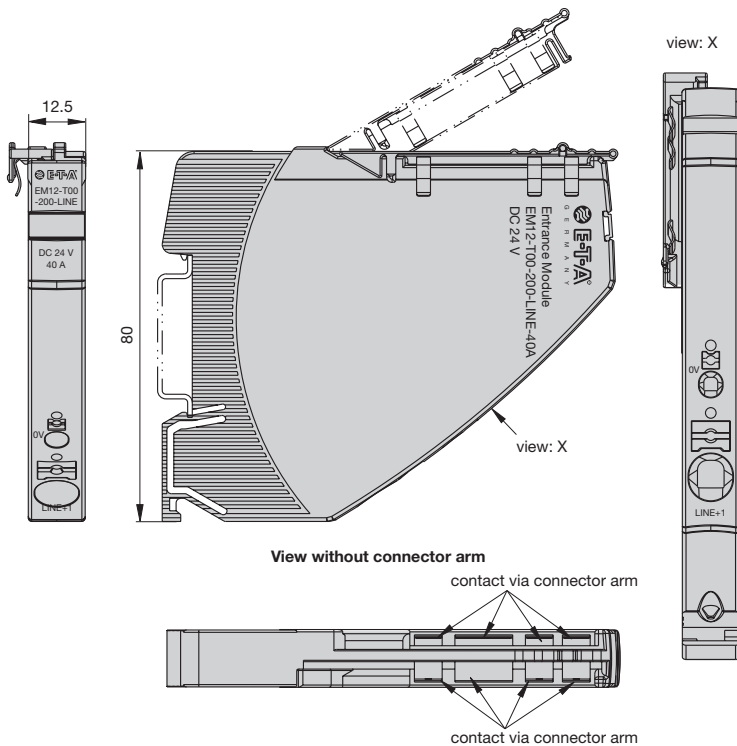

Technical data

Please observe general data of REX / EM / PM	
Operating voltage U_B	DC 24 V (18...30 V)
Operating current I_B	max. load 40 A
Insulation co-ordination	0.8 kV / pollution degree 2
Screw terminals	LINE+1
Push-in terminal PT 10	0.5 mm ² ... 10 mm ² , flexible AWG24 – AWG8 rigid
stripping length	18 mm
Screw terminals	0 V
Push-in terminal PT 2.5	0.14mm ² ... 2.5mm ² , flexible AWG24 – AWG14 rigid
stripping length	8 mm ... 10 mm
Dimensions (w x h x d)	12.5 x 80 x 98 mm
Mass	approx. 52 g
Approvals	UL 2367, File # E306740; cULus508listed, File # E492388; pending

Schematic diagram

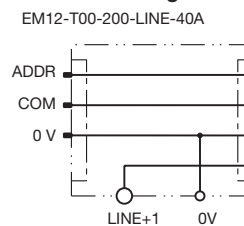

7

