

swissbit®

Product Data Sheet

Industrial SD / SDHC Memory Card

S-600 Series

UHS-I Interface, SLC

Standard and Extended
Temperature Grade

Date: August 18, 2022
Revision: 1.02



Contents

1.	PRODUCT SUMMARY	3
2.	PRODUCT FEATURES	4
3.	ORDERING INFORMATION	5
4.	PRODUCT DESCRIPTION	6
	4.1 PERFORMANCE SPECIFICATIONS	6
	4.2 ENVIRONMENTAL SPECIFICATIONS	7
	4.3 REGULATORY COMPLIANCE	8
	4.4 PHYSICAL DIMENSIONS	8
	4.5 RELIABILITY	8
	4.6 ENDURANCE	9
5.	USER DENSITY SPECIFICATION	9
6.	CARD PHYSICAL	10
7.	ELECTRICAL INTERFACE	11
	7.1 ELECTRICAL DESCRIPTION	11
	7.2 POWER UP / POWER DOWN BEHAVIOR AND RESET	12
	7.3 DC CHARACTERISTICS	12
	7.4 SIGNAL LOADING	13
	7.5 AC CHARACTERISTICS	13
8.	HOST ACCESS SPECIFICATION	14
	8.1 SD AND SPI BUS MODES	14
	8.2 CARD REGISTERS	15
9.	LIFE TIME MONITORING	20
10.	PART NUMBER DECODER	21
	10.1 MANUFACTURER	21
	10.2 MEMORY TYPE	21
	10.3 PRODUCT TYPE	21
	10.4 DENSITY	21
	10.5 PLATFORM	21
	10.6 PRODUCT GENERATION	21
	10.7 MEMORY ORGANIZATION	21
	10.8 TECHNOLOGY	21
	10.9 CHANNELS	21
	10.10 FLASH CODE	22
	10.11 TEMPERATURE OPTION	22
	10.12 DIE CLASSIFICATION	22
	10.13 PIN MODE	22
	10.14 CONFIGURATION XYZ	22
	10.15 OPTION	22
11.	MARKING SPECIFICATION	23
	11.1 FRONT SIDE	23
	11.2 BACK SIDE MARKING	23
12.	REVISION HISTORY	24

S-600 Series – Industrial SD/SDHC Memory Card, SLC

512 MBytes up to 32 GBytes

1. Product Summary

- **Capacities:** 512 MBytes, 1 GBytes, 2 GBytes, 4 GBytes, 8 GBytes, 16 GBytes, 32 GBytes
- **Form Factor:** Standard SD Memory Card 32.0mm x 24.0mm x 2.1mm and Write Protect slider
- **Compliance:** Fully compliant with SD Memory Card specification 5.0 (4-32GB) / 3.0 (512MB-2GB)
 - Up to speed class 10/U3/V30 according SD5.0 specification
 - Fully compatible with UHS-I/SDR104 hosts
 - SD2.0 SDHC backward compliant, default speed and high speed mode
 - FAT16 / FAT32
- **Environmental:** RoHS / REACH Compliant
- **Compatibility:** Support SD SPI mode
- **Performance (max. capacity):**
 - SD Default speed
 - SD High speed
 - SD UHS-I
 - Read performance: sequential read up to 95 MBytes/s
 - Write performance: sequential write up to 55 MBytes/s
- **Operating Temperature Range:**
 - Extended: -25 °C to 85 °C
 - Industrial: -40 °C to 85 °C
- **Storage Temperature Range:** -40 °C to 100 °C
- **Operating Voltage:** 2.7 ... 3.6V (Low-power CMOS technology)
- **Data Retention:** 10 Years @ Life Begin / 1 Year @ Life End
- **Reliability:**
 - Mean Time Between Failure (MTBF): > 3,000,000 hours
 - Number of insertions: up to 20,000
- **Shock/Vibration:** 1,500 *g* / 50 *g*
- **Electromagnetic Compatibility Test:** Radiated Emission; Radiated Immunity; Electrostatic Discharge

¹ The verification of host system and storage device compatibility is in customer's responsibility. Swissbit can provide guidance and support on request.

2. Product Features

- Optimized FW algorithms especially for read/write access, highest random write performance and best endurance with long data retention
 - Designed for usage in applications with highest requirements regarding reliability like data logging, POS/POI, Medical and other demanding use-cases
 - Especially suitable for intensive read/write operations
 - Advanced power-off reliability technology
 - Wear Leveling technology
 - Equal wear leveling of static and dynamic data. The wear leveling assures that dynamic data as well as static data is balanced evenly across the memory. With that the maximum write endurance of the device is guaranteed
 - The S-600 series is optimized for high read/write traffic for demanding industrial applications.
 - Read Disturb Management
 - The read commands are monitored and the content is refreshed when critical levels have occurred
 - Data Care Management
 - The interruptible background process maintain the user data for Read Disturb effects or Retention degradation due to high temperature effects
 - Near miss ECC technology
 - Minimize the risk of uncorrectable bit failure over the product life time. Each read command analyzes the ECC margin level and refresh data if necessary
 - Diagnostic features with Life Time Monitoring tool support
- High reliability
 - SLC Flash
 - The product is optimized for long life cycle that requires good data retention because of high temperature mission profile
 - Number of card insertions/removals 20,000
 - Industrial Temperature range -40° up to 85°C inclusive full cross temperature support²
 - SIP (System In Package) process for extreme dust, water and ESD proof
- Controlled "Locked" BOM & PCN process
- Manufactured in a TS 16949 certified factory
- Customized options like CID registers, CPRM keys, firmware incl. settings and marking on request
- In-field firmware update³
- Swissbit Device Manager (SBDM) Tool and SDK for SBDM (on request)



² Cross temp. stability of 125 Kelvin: Feasible temperature difference between write/read of same data, e.g. write @ -40°C , read @ 85°C .

³ The support of In-Field FW update capabilities on host systems is recommended.

3. Ordering Information

Table 1: Standard Product List

Capacity	Extended Temperature	Industrial Temperature
	Part Number	Part Number
512 MBytes	SFSD0512LgAS1T0-E-xx-2y1-STD	SFSD0512LgAS1T0-I-xx-2y1-STD
1 GBytes	SFSD1024LgAS1T0-E-xx-2y1-STD	SFSD1024LgAS1T0-I-xx-2y1-STD
2 GBytes	SFSD2048LgAS1T0-E-xx-2y1-STD	SFSD2048LgAS1T0-I-xx-2y1-STD
4 GBytes	SFSD4096LgAS1T0-E-xx-2y1-STD	SFSD4096LgAS1T0-I-xx-2y1-STD
8 GBytes	SFSD008GLgAS1T0-E-xx-2y1-STD	SFSD008GLgAS1T0-I-xx-2y1-STD
16 GBytes	SFSD016GLgAS1T0-E-xx-2y1-STD	SFSD016GLgAS1T0-I-xx-2y1-STD
32 GBytes	SFSD032GLgAS1T0-E-xx-2y1-STD	SFSD032GLgAS1T0-I-xx-2y1-STD

g = product generation; xx = flash configuration; y = firmware revision

Table 2: Available Part Numbers

Capacity	Extended Temperature	Industrial Temperature
	Part Number	Part Number
512 MBytes	SFSD0512L1AS1T0-E-ME-221-STD	SFSD0512L1AS1T0-I-ME-221-STD
1 GBytes	SFSD1024L1AS1T0-E-DF-221-STD	SFSD1024L1AS1T0-I-DF-221-STD
2 GBytes	SFSD2048L1AS1T0-E-QG-221-STD	SFSD2048L1AS1T0-I-QG-221-STD
4 GBytes	SFSD4096L1AS1T0-E-ME-221-STD	SFSD4096L1AS1T0-I-ME-221-STD
8 GBytes	SFSD008GL1AS1T0-E-DF-221-STD	SFSD008GL1AS1T0-I-DF-221-STD
16 GBytes	SFSD016GL1AS1T0-E-QG-221-STD	SFSD016GL1AS1T0-I-QG-221-STD
32 GBytes	SFSD032GL1AS1T0-E-NG-221-STD	SFSD032GL1AS1T0-I-NG-221-STD

4. Product Description

The SD Memory Card is a small form factor non-volatile memory card which provides high capacity data storage. Its aim is to capture, retain and transport data, audio and images, facilitating the transfer of all types of digital information between a large variety of digital systems.

The card operates in two basic modes:

- SD/SDHC and UHS-I card modes
- SPI mode

The SD Memory Card also supports SD Default and High Speed mode with up to 50MHz clock frequency as well as UHS-I modes.

The cards are compliant with

- SD Memory card Specification Part 1, Physical layer Specification V3.01 (5.00)
- SD Memory card Specification Part 2, File System Specification V3.00
- SD Memory card Specification Part 3, Security Specification V3.00
- SD Memory Card Addendum V4.00
- Standard Size SD Card Mechanical Addendum Ver7.00

Simplified specifications are available at <https://www.sdcard.org/>

The SD Card has an internal intelligent controller which manages interface protocols, data storage and retrieval as well as hardware BCH Error Correction Code (ECC), defect handling, diagnostics and clock control. The advanced wear leveling mechanism assures an equal usage of the Flash memory cells to extend the life time.

The hardware BCH-code ECC allows to detect and correct up to 24 defect bits per 1kByte.

The controller performs control read operations and checks the consistence of the data. If an error of some bits is detected, the card refreshes all data in the flash cells to prevent data retention problems.

The card has a power-loss management feature to prevent data corruption after power-down.

The cards are RoHS compliant and lead-free.

4.1 Performance Specifications

Table 3: Read/Write Performance

System Performance	typ							Unit
	512MB	1GB	2GB	4GB	8GB	16GB	32GB	
Sequential Read	33	35	35	95	95	95	95	MB/s
Sequential Write	16	20	21	45	55	55	55	
Random Read 4k	850	850	850	1200	1200	1200	1200	IOPS
Random Write 4k	1000	1100	1200	800	800	800	800	
Speed class	10/U1			10/U3/V30				-

The values are measured using Crystal Disk Mark 7.0.0 at 25°C. Performance depends on flash type and number, file/cluster size, and interface speed.

The cards use thermal management to ensure stability and reliability at high operating temperatures. Performance can be lower depending on ambient temperature and airflow.

4.2 Environmental Specifications

4.2.1 Recommended Operating Conditions

The recommended operating conditions for the S-600 SD Memory Card are provided in Table 4 below.

Table 4: SD Memory Card recommended operation conditions

Parameter	Value ⁴
Extended Operating Temperature	-25 °C to 85 °C
Industrial Operating Temperature	-40 °C to 85 °C

4.2.2 Recommended Storage Conditions

The recommended storage conditions are listed below in Table 5.

Table 5: SD Memory Card recommended Storage Conditions

Parameter	Value ⁵
Extended Storage Temperature	-25 °C to 100 °C
Industrial Storage Temperature	-40 °C to 100 °C

4.2.3 Humidity & EMC

The humidity and EMC conditions are listed below in Table 6.

Table 6: Humidity & EMC

Parameter	Value
Humidity (Non-Condensing)	85% RH @85°C 1000h
ESD	<p>up to ±4 kV (contact discharge), according to IEC61000-4-2 and SDA, Human Body Model 150pF/ 3300hm, on each contact pad, non-operating</p> <p>up to ±15 kV, (air discharge), according to IEC61000-4-2 and SDA, Human Body Model 150pF/ 3300hm, isolated contact pad area, non-operating</p>

4.2.4 Environmental Conditions

Table 7: Environmental Conditions

Parameter	Value
UV light exposure	UV: 254nm, 15Ws/cm ² according to ISO7816-1
X-Ray	0.1 Gy 70keV to 140KeV (ISO7816-1) according SDA
Durability	20,000 mating cycles
Drop Test	1.5m free fall
Bending / Torque	10N / 0.15Nm ±2.5° max
Mechanical Shock	1500G, 0.5ms, half sine wave ±xyz-axis, 4 pulses each non-operating, JESD22B110/B104 Condition B
Vibration	50G, p-p, 20..2000Hz, sweep xyz-axis, 4 pulses each, non-operating, MIL-STD-883 M2007.3 Condition B

⁴ High Temperature storage without operation reduces the data retention, in operation the data will be refreshed, if data error issues were detected.

⁵ High Temperature storage without operation reduces the data retention, in operation the data will be refreshed, if data error issues were detected.

4.3 Regulatory Compliance

The S-600 devices comply with the regulations / standards listed in Table 8.

Table 8: Regulatory Compliance

Abbreviation	Regulation/ Standard
EMC	CE – 2014/30/EU FCC – 47 CFR Part 15 UKCA – S.I. 2016 No. 1091 and S.I. 2012 No. 3032
RoHS	2011/65/EU with 2015/863/EU and 2017/2102/EU
REACH	1907/2006/EU and 207/2011/EU
WEEE	2012/19/EU

4.4 Physical Dimensions

The physical dimensions of the S-600 SD Memory Card are listed in the following table.

Table 9: Measured Physical Dimensions

Physical Dimensions		Unit
Length	32.00±0.1	mm
Width	24.00±0.1	
Thickness (Max)	2.10±0.15	
Weight (Typ)	2	g

4.5 Reliability

Table 10: Reliability

Parameter	Value ⁶
Data Retention at beginning @ 40°C	10 years
Data Retention at life end (100k PE cycles) @ 40°C	1 year

⁶ After every 50 power on cycle the card reads the whole flash and performs a data refresh if necessary. So, the data retention can be much longer in most use cases.

4.6 Endurance

Endurance represented as TeraBytes Written (TBW) is provided in the following Table 11:

Table 11: Endurance^{7, 8}

Capacity	TeraBytes Written (TBW) @ Seq. Write 1MB Operation	TeraBytes Written (TBW) @ Random Write 128kB Operation	TeraBytes Written (TBW) @ Random Write 4kB Operation
512 MBytes	53	21	4,3
1 GByte	106	31	7,1
2 GBytes	212	62	13,9
4 GBytes	425	128	27
8 GBytes	851	179	41
16 GBytes	1702	349	76
32 GBytes	3405	961	192

5. User density specification

The S-600 drive geometry is set to report industry standard LBA settings per the IDEMA standard (LBA1-03). The values for each capacity are shown below in Table 12.

Table 12: SD Memory Card capacity specification

Capacity	Total LBA	User Addressable Bytes
512 MBytes	967,680	495,452,160
1 GBytes	1,953,792	1,000,341,504
2 GBytes	3,938,304	2,016,411,648
4 GBytes	7,774,208	3,980,394,496
8 GBytes	15,802,368	8,090,812,416
16 GBytes	31,834,112	16,299,065,344
32 GBytes	62,333,952	31,914,983,424

⁷ The specified TBW is valid, if the amount of data is spread evenly over at least 24 months. Higher daily data volume or frequent writing below 0°C reduces the specified TBW. The drive endurance limit, also called EOL or 0% remaining life, is defined as TBW or DWPD over the product's limited lifetime warranty period. TBW calculations refer to the JEDEC JESD218A and JESD219A standard for SSD device life and endurance measurement techniques if not otherwise specified.

⁸ Sequential write 1MB simulates a continuous stream recording on a drive which has been preconditioned with a sequential write of the complete drive, Random Write 128KB or 4KB represent data logging applications with large or small block sizes.

6. Card physical

The SD Memory Card contains a single chip controller and Flash memory module(s). The controller interfaces with a host system allowing data to be written to and read from the Flash memory module(s).

Figure 1: Simplified mechanical dimensions SD Memory Card

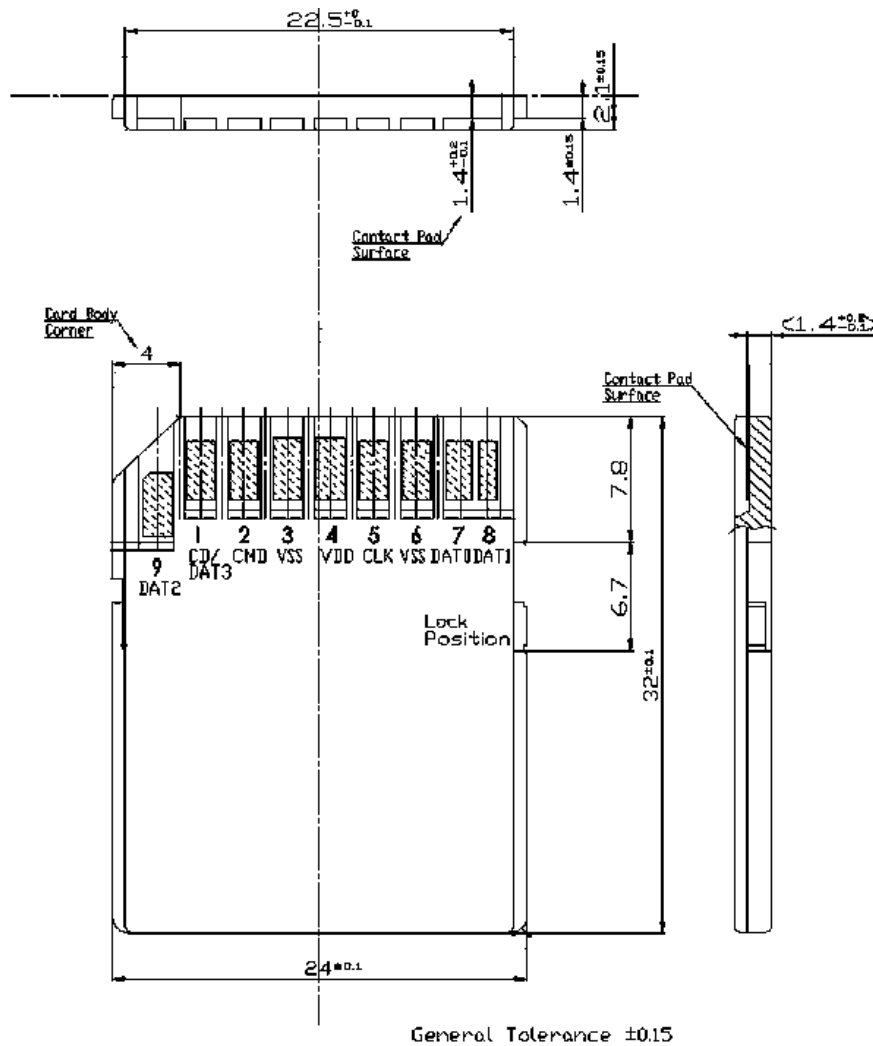

7. Electrical interface

7.1 Electrical description

Figure 2: SD Memory Card shape and interface (Bottom view)

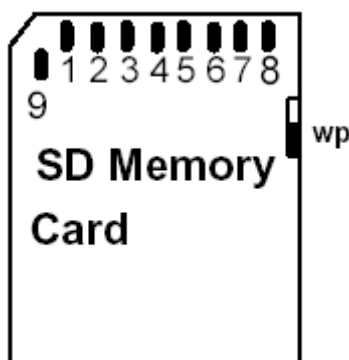

Table 13: Pad assignment – SD Mode

Pin	SD Mode		
	Name	Type ⁹	Description
1	CD/DAT3 ¹⁰	I/O/PP ¹¹	Card Detect/ Data Line [Bit 3]
2	CMD	PP	Command/Response
3	VSS1	S	Supply voltage ground
4	VDD	S	Supply voltage
5	CLK	I	Clock
6	VSS2	S	Supply voltage ground
7	DAT0	I/O/PP	Data Line [Bit 0]
8	DAT1 ¹²	I/O/PP	Data Line [Bit 1]
9	DAT2 ¹³	I/O/PP	Data Line [Bit 2]

Table 14: Pad assignment – SPI Mode

Pin	SPI Mode		
	Name	Type ⁹	Description
1	CS	I ¹¹	Chip Select (neg true)
2	DI	I	Data In
3	VSS	S	Supply voltage ground
4	VDD	S	Supply voltage
5	SCLK	I	Clock
6	VSS2	S	Supply voltage ground
7	DO	O/PP	Data Out
8	RSV		
9	RSV		

⁹ S: power supply; I: input; O: output using push-pull drivers; PP: I/O using push-pull drivers

¹⁰ The extended DAT lines (DAT1–DAT3) are input on power up. They start to operate as DAT lines after SET_BUS_WIDTH command. The Host shall keep its own DAT1–DAT3 lines in input mode, as well, while they are not used.

¹¹ At power up this line has a 50kOhm pull up enabled in the card. This resistor serves two functions Card detection and Mode Selection. For Mode Selection, the host can drive the line high or let it be pulled high to select SD mode. If the host wants to select SPI mode it should drive the line low. For Card detection, the host detects that the line is pulled high. This pull-up should be disconnected by the user, during regular data transfer, with SET_CLR_CARD_DETECT (ACMD42) command

¹² DAT1 line may be used as Interrupt Output (from the Card) in SDIO mode during all the times that it is not in use for data transfer operations (refer to "SDIO Card Specification" for further details).

¹³ DAT2 line may be used as Read Wait signal in SDIO mode (refer to "SDIO Card Specification" for further details).

7.2 Power up / Power down behavior and reset

7.2.1 Power up

The host can start with communication 1ms after 2.7V is reached according the SDA specification. That should perform 74 clock cycles and start with the sequence CMD0, CMD8, ACMD41 until card is ready as described in the SD specification 3.00.

7.2.2 Power down

When the power falls below 2.6V the controller stops the communication to the flash, but enables the flash to finish a started flash program operation (if voltage drop is not fast).

After next initialization the controller checks the last written data for consistency and refreshes the data. Either the new or the old data (if the write operation could not be finished) are available.

7.2.3 Power drop

If the voltage drops below 2.6V and rises again, the card performs a reset. The card must be initialized like after a power on.

7.2.4 Operation below minimum voltage

512MB-2GB

If the card is initialized from the host (ACMD41) below 2.7V the card may not be recognized.

4GB-32GB

If the card initialization is performed below the specified voltage of 2.7V, the card may be detected as 1MB card with no useful data. In this case the host should power off and on the card and start initialization above 2.7V.

7.3 DC characteristics

Measurements are at recommended Operating Conditions unless otherwise specified.

Table 15: DC Characteristics¹⁴

Symbol	Parameter	Density	Min	Typ	Max	Unit	Notes
I _{DD}	Operating Current Read (SDR50 max. 2GB SDR104 >2GB)	512MB		75	80	mA	@ 25°C
I _{DD}		1GB-2GB		80	85	mA	@ 25°C
I _{DD}		4GB-32GB		125	135	mA	@ 25°C
I _{DD}	Operating Current Write (SDR50 max. 2GB SDR104 >2GB)	512MB		75	80	mA	@ 25°C
I _{DD}		1GB-2GB		95	100	mA	@ 25°C
I _{DD}		4GB		100	105	mA	@ 25°C
I _{DD}		8GB-32GB		120	130	mA	@ 25°C
I _{DD}	Background read and refresh ¹⁵	512MB-2GB		80	100	mA	@ 25°C
I _{DD}		4GB-32GB		105	120	mA	@ 25°C
I _{DD}	Pre-initialization Standby Current			5	15	mA	@ 25°C
I _{DD}	Post-initialization Standby Current ¹⁶			10	12	mA	@ 25°C
I _{DD}	Post-initialization Standby Current ¹⁷			10	12	mA	@ 25°C
I _{LI}	Input Leakage Current		-2		2	µA	without pull up R
I _{LO}	Output Leakage Current		-2		2	µA	without pull up R

Table 16: SD Memory Card Recommended Operating Conditions

Symbol	Parameter	min	typ	max	unit
V _{DD}	Supply Voltage				
	Normal Operating Status	2.7	3.3	3.6	V
-	Power Up Time (from 0V to VDD min)			250	ms

¹⁴ Target values

¹⁵ The card can perform auto data read of the whole card to check for ECC errors and performs data refresh

¹⁶ Before auto read the idle current is larger than the typical idle current after auto read

7.4 Signal Loading

According to SD specification

7.5 AC characteristics

7.5.1 Default Speed mode (0–25MHz)

According to SD specification

7.5.2 High Speed mode (0–50MHz)

According to SD specification

7.5.3 UHS modes

UHS modes were driven with a signal level of 1.8V.
The cards support following UHS-I modes:

Table 17: Supported UHS-I modes for max. 2GB cards

Host request	Card Modes (to select by host)	Max. Burst MB/s	Max. Clock frequency MHz
SDR12	SDR12	up to 12.5	up to 25
SDR25	SDR12, SDR25	up to 25	up to 50
SDR50	SDR12, SDR25, SDR50	up to 50	up to 100
DDR50	SDR12, SDR25, SDR50, DDR50	up to 50	50 (rising and falling edge)
SDR104	SDR12, SDR25, SDR50, DDR50	up to 50	up to 100

Table 188: Supported UHS-I modes for >2GB cards

Host request	Card Modes (to select by host)	Max. Burst MB/s	Max. Clock frequency MHz
SDR12	SDR12	up to 12.5	up to 25
SDR25	SDR12, SDR25	up to 25	up to 50
SDR50	SDR12, SDR25, SDR50	up to 50	up to 100
DDR50	SDR12, SDR25, SDR50, DDR50	up to 50	50 (rising and falling edge)
SDR104	SDR12, SDR25, SDR50, DDR50, SDR104	up to 104	up to 208

According to SD specification

8. Host access specification

The following chapters summarize how the host accesses the card:

- Chapter 8.1 summarizes the SD and SPI buses.
- Chapter 8.2 summarizes the registers.

8.1 SD and SPI Bus Modes

The card supports SD and the SPI Bus modes. Application can chose either one of the modes. Mode selection is transparent to the host. The card automatically detects the mode of the reset command and will expect all further communication to be in the same communication mode. The SD mode uses a 4-bit high performance data transfer, and the SPI mode provides compatible interface to MMC host systems with little redesign, but with a lower performance.

8.1.1 SD Bus Mode Protocol

The SD Bus mode has a single master (host) and multiple slaves (cards) synchronous topology. Clock, power, and ground signals are common to all cards. After power up, the SD Bus mode uses DAT0 only; after initialization, the host can change the cards' bus width from 1 bit (DAT0) to 4 bits (DAT0-DAT3). In high speed mode, only one card can be connected to the bus.

Communication over the SD bus is based on command and data bit streams which are initiated by a start bit and terminated by a stop bit.

- **Command:** a command is a token which starts an operation. A command is sent from the host either to a single card (addressed command) or to all connected cards (broadcast command). A command is transferred serially on the CMD line.
- **Response:** a response is a token which is sent from an addressed card, or (synchronously) from all connected cards, to the host as an answer to a previously received command. A response is transferred serially on the CMD line.
- **Data:** data can be transferred from the card to the host or vice versa. Data is transferred via the data lines.

8.1.2 SPI Bus Mode Protocol

The Serial Peripheral Interface (SPI) Bus is a general purpose synchronous serial interface. The SPI mode consists of a secondary communication protocol. The interface is selected during the first reset command after power up (CMD0) and it cannot be changed once the card is powered on.

While the SD channel is based on command and data bit streams which are initiated by a start bit and terminated by a stop bit, the SPI channel is byte oriented. Every command or data block is built of 8-bit bytes and is byte aligned to the CS signal.

The card identification and addressing methods are replaced by a hardware Chip Select (CS) signal. There are no broadcast commands. For every command, a card (slave) is selected by asserting (active low) the CS signal.

The CS signal must be continuously active for the duration of the SPI transaction (command, response and data). The only exception occurs during card programming, when the host can de-assert the CS signal without affecting the programming process.

The bidirectional CMD and DAT lines are replaced by unidirectional dataIn and dataOut signals.

Table 19: SPI Bus Signals

Signal	Description
/CS	Host to card chip select
CLK	Host to card clock signal
Data In	Host to card data signal
Data Out	Card to host data signal
Vdd, Vss	Power and ground

8.1.3 Mode Selection

The SD Memory Card wakes up in the SD mode. It will enter SPI mode if the CS signal is asserted (negative) during the reception of the reset command (CMD0) and the card is in idle_state. If the card recognizes that the SD mode is required it will not respond to the command and remain in the SD mode.

If SPI mode is required the card will switch to SPI and respond with the SPI mode R1 response.

The only way to return to the SD mode is by entering the power cycle. In SPI mode the SD Memory Card protocol state machine is not observed. All the SD Memory Card commands supported in SPI mode are always available.

During the initialization sequence, if the host gets Illegal Command indication for ACMD41 sent to the card, it may assume that the card is Multimedia Card. In that case it should re-start the card as Multimedia Card using CMD0 and CMD1.

8.2 Card registers

The SD Memory Card has the following registers.

Table 20: SD Memory Card registers

Register name	Bit width	Description	Function
CID	128	Card Identification information	This register contains the card identification information used during the Card Identification phase.
OCR	32	Operation Conditions Registers	This register describes the operating voltage range and contains the status bit in the power supply.
CSD	128	Card specific information	This register provides information on how to access the card content. Some fields of this register are writeable by PROGRAM_CSD (CMD27).
SCR	64	SD Memory Card's Special features	This register provides information on special features.
RCA ¹⁷	16	Relative Card Address	This register carries the card address is SD Card mode.
SSR	512	SD Status	information about the card proprietary features and vendor specific life time information

Table 21: CID registers

Register name	Bit width	Description	Function
MID	8	Manufacture ID	0x5d
OID	16	OEM/Application ID	0x5342
PNM	40	Product Name	SB PNM Naming
PRV	8	Product Revision	0xgg
PSN	32	Product Serial Number	xxxxxxxx
—	4	Reserved	0x0
MDT	12	Manufacture Date	oxyym
CRC	7	Check sum of CID contents	chksum
—	1	Not used; always=1	1

¹⁷ RCA register is not available in SPI mode

Table 22: OCR register

OCR bit position	VDD voltage windows	Typ. value	OCR bit position	VDD voltage window	Typ. value
0-3	Reserved	0	15	2.7-2.8	1
4	1.6-1.7	0	16	2.8-2.9	1
5	1.7-1.8	0	17	2.9-3.0	1
6	1.8-1.9	0	18	3.0-3.1	1
7	1.9-2.0	0	19	3.1-3.2	1
8	2.0-2.1	0	20	3.2-3.3	1
9	2.1-2.2	0	21	3.3-3.4	1
10	2.2-2.3	0	22	3.4-3.5	1
11	2.3-2.4	0	23	3.5-3.6	1
12	2.4-2.5	0	24	Switching to 1.8V accepted	1
13	2.5-2.6	0	25-29	Reserved	
14	2.6-2.7	0	30	Card Capacity Status (CCS)	*18
			31	0=busy; 1=ready	*19

¹⁸ This bit is valid only when the card power up status bit is set

¹⁹ This bit is set to LOW if the card has not finished the power up routine

Table 23: CSD register

Register name	Bits	Bit width	Description	Typ. value (max. 2GB)	Typ. value (>2GB)
CSD_STRUCTURE	127:126	2	CSD structure	00	01
—	125:120	6	Reserved	00000	00000
TAAC	119:112	8	Data read access time 1	00101111	00001110
NSAC	111:104	8	Data read access time 2 (CLK cycle)	00000000	00000000
TRAN_SPEED	103:96	8	Data transfer rate	00110010 Default speed 00001011 SDR 50 or other values	00110010 Default speed 00001011 SDR 50 or other values
CCC	95:84	12	Card command classes	01011110101	01011010101
READ_BLK_LEN	83:80	4	Read data block length	1001	1001
READ_BLK_PARTIAL	79	1	Partial blocks for read allowed	1	0
WRITE_BLK_MISALIGN	78	1	Write block misalignment	0	0
READ_BLK_MISALIGN	77	1	Read block misalignment	0	0
DSR_IMP	76	1	DSR implemented	0	0
—	75:74	2	Reserved	00	—
C_SIZE	73:62	12	Device size	xxx ²⁰	—
VDD_R_CURR_MIN	61:59	3	VDD min read current	111	—
VDD_R_CURR_MAX	58:56	3	VDD max read current	111	—
VDD_W_CURR_MIN	55:53	3	VDD min write current	111	—
VDD_W_CURR_MAX	52:50	3	VDD max write current	111	—
C_SIZE_MULT	49:47	3	Device size multiplier	111 ²⁰	—
—	75:70	6	Reserved	—	000000
C_SIZE	69:48	22	Device size	—	xxx ²⁰
—	47	1	Reserved	—	0
ERASE_BLK_EN	46	1	Erase single block enable	1	1
SECTOR_SIZE	45:39	7	Erase sector size	1111111	1111111
WP_GRP_SIZE	38:32	7	Write protect group size	0000000	0000000
WP_GRP_ENABLE	31	1	Write protect group enable	1	0
—	30:29	2	Reserved	00	00
R2W_FACTOR	28:26	3	Write speed factor	010	010
WRITE_BLK_LEN	25:22	4	Write data block length	1001 ²⁰	1001 ²⁰
WRITE_BLK_PARTIAL	21	1	Partial blocks for write allowed	0	0

²⁰ Drive size and block sizes vary with card capacity

–	20:16	5	Reserved	00000	00000
FILE_FORMAT_GRP	15	1	File format group	0 W(1)	0 W(1)
COPY	14	1	Copy flag	0 W(1)	0 W(1)
PERM_WRITE_PROTECT	13	1	Permanent write protection	0 W(1)	0 W(1)
TMP_WRITE_PROTECT	12	1	Temporary write protection	0 W	0 W
FILE_FORMAT	11:10	2	File format	00 W(1)	00 W(1)
–	9:8	2	Reserved	00 W	00 W
CRC	7:1	7	Checksum of CSD contents	xxxxxxx W	xxxxxxx W
–	0	1	Always=1	1	1

≤2GB

memory capacity = BLOCKNR * BLOCK_LEN

Where

BLOCKNR = (C_SIZE+1) * MULT

MULT = $2^{C_SIZE_MULT+2}$ (C_SIZE_MULT < 8)

BLOCK_LEN = $2^{READ_BL_LEN}$, (READ_BL_LEN < 12)

>2GB

memory capacity = (C_SIZE+1) * 512kByte

W value can be changed with CMD27 (PROGRAM_CSD)

W(1) value can be changed ONCE with CMD27 (PROGRAM_CSD)

Table 24: SCR register

Field	Bits	Bit width	Typ. value	Remark
SCR_STRUCTURE	63:60	4	0000	SCR 1.01...2.00
SD_SPEC	59:56	4	0010	SD 2.0 or 3.0
DATA_STAT_AFTER_ERASE	55	1	1	data are 0xFF after erase
SD_SECURITY	54:52	3	010 011	1.01 (SDSC) 2.00 (SDHC)
SD_BUS_WIDTHS	51:48	4	0101	1 or 4 bit
SD_SPEC3	47	1	1	yes → ≥ SD3.0
EX_SECURITY	46:43	4	0000	no extended security
SD_SPEC4	42:42	1	0 / 1	no / yes
SD_SPECX	41:38	4	0 / 1	Version 3.xx / Version 5.x
Reserved	37:36	9	0	
CMD_SUPPORT	35:32	2	00 11	CMD23 CMD20 not supported CMD23 CMD20 supported

Table 25: RCA register

Field	Bits	Bit width
RCA	16	0x0000 ²¹

²¹ After initialization the card can change the RCA register

Table 26: SSR register

Field	Bits	Bit width	Typ. value	Remark
Data bus width	511:510	2	0x2 ²²	4 bit width
Secured mode	509:509	1	0x0	not secured
Reserved for security	508:502	7	0x00	-
Reserved	501:496	6	0x00	-
SD card type	495:480	16	0x0000	Regular SD
Size protected area	479:448	32	0x02800000 0x05000000	40MB 80MB
Speed class	447:440	8	0x04	Class 10
Move performance	439:432	8	0x05	5 MB/s sequential write
Allocation unit size	431:428	4	0x7 0x9	1 MiB 4 MiB
Reserved	427:424	4	0x0	
Erase unit size	423:408	16	0x0001	1 AU
Erase unit timeout	407:402	6	0x01	1 second
Erase unit offset	401:400	2	0x1	1 seconds
UHS mode Speed Grade	399:396	4	0x1 / 0x3	UHS Grade 1 / 3
Allocation unit size in UHS mode	395:392	4	0x7 0x9	1 MiB 4 MiB
Reserved	391:312	80		
Data structure version identifier, currently 1	311:304	8	0x01	version 1
Number of manufacturer marked defect blocks	303:288	16	0x0008	8 initial BB
Number of initial spare blocks (worst chip)	287:272	16	0x00bf	191 spare blocks
Number of initial spare blocks (sum over all chips)	271:256	16	0x017e	382 spare blocks
Percentage of remaining spare blocks (worst chip)	255:248	8	0x64 ²²	100%
Percentage of remaining spare blocks (all chips)	247:240	8	0x64 ²²	100%
Number of uncorrectable ECC errors (not including ECC errors during startup)	239:224	16	0x0000 ²²	0 uncorrectable errors
Number of correctable ECC errors (not including ECC errors during startup)	223:192	32	0x0045074b ²²	4523851 correctable ECC errors
Lowest wear level class	191:176	16	0x0000 ²²	0
Highest wear level class	175:160	16	0x0000 ²²	0
Wear level threshold	159:144	16	0x01ff	512 block erases per WL class
Total number of block erases	143:96	48	0x00...1ff0 ²²	8176 block erase commands
Number of flash blocks, in units of 256 blocks	95:80	16	0x0020	8192 flash blocks
Maximum flash block erase count target, in wear level class units	79:64	16	0x0075	Flash endurance 117 WL classes (59904 erases)
Power on count	63:32	32	0x00000003 ²²	3x power on
Firmware version	31:0	32	0xYYMMDDXX	Firmware version

Bit 311:0 are vendor specific, example values in the table

²² Value change in operation

9. Life Time Monitoring

The products support life time monitoring with a vendor specific SD command CMD56 with argument 0x53420001 (read transfer). CMD56 follows the SD protocol specification and returns 512 bytes of data. All multi-byte values are in big endian order (most significant byte first).

Table 27: Life Time Monitoring

Field	Bytes	Byte width	Remark
Unique ID	0:7	8	53 77 69 73 73 62 69 74 «Swissbit» in ASCII
Reserved	8:15	8	All 0x00
SD CID Register	16:31	16	See chapter 8.2
Firmware Revision	32:47	16	ASCII Null-Terminated
User Area Rated Cycles	48:51	4	
User Area Max. Cycle Coun	52:55	4	
User Area Total Cycle Count	56:59	4	
User Area Average Cycle Count	60:63	4	
Reserved	64:67	4	All 0x00
System Area Max. Cycle Count	68:71	4	
System Area Total Cycle Count	72:75	4	
System Area Average Cycle Count	76:79	4	
Remaining Card Lifetime Percent (user area)	80:80	1	
Reserved	81:85	5	All 0x00
Current SD Card Speed Mode	86:86	1	0x00: Default Speed 0x01: High Speed 0x10: SDR12 0x11: SDR25 0x12: SDR50 0x14: DDR50 0x18: SDR104
Current SD Card Bus Width	87:87	1	0x00: 1 bit width 0x10: 4 bit width
Current Spare Blocks User Area	88:91	4	
Current Spare Blocks System Area	92:95	4	
Runtime Bad Blocks User Area	96:99	4	
Runtime Bad Blocks System Area	100:103	4	
Refresh Count User Area	104:107	4	
Refresh Count System Area	108:111	4	
Host Interface CRC count	112:115	4	
Power Cycle Counter	116:119	4	
Reserved	120:511	392	

10. Part Number Decoder

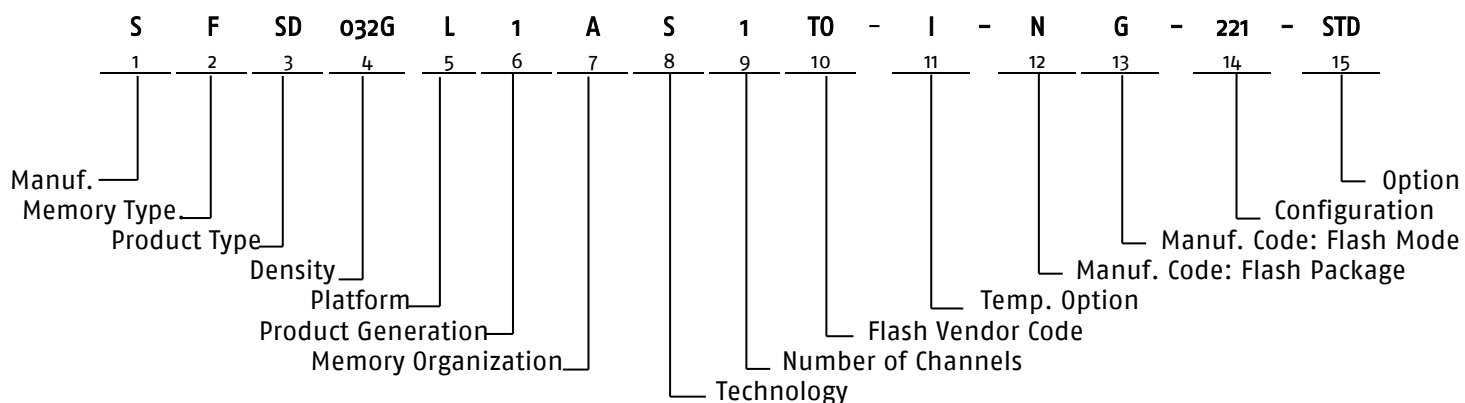

10.1 Manufacturer

Swissbit code	S
---------------	---

10.2 Memory Type

Flash	F
-------	---

10.3 Product Type

SD Memory Card	SD
----------------	----

10.4 Density

512 MByte	0512
1 GByte	1024
2 GByte	2048
4 GByte	4096
8 GByte	008G
16 GBytes	016G
32 GBytes	032G

10.5 Platform

SD Memory Card	L
----------------	---

10.6 Product Generation

10.7 Memory Organization

x8	A
----	---

10.8 Technology

SD Memory Card controller S-6xx platform	S
--	---

10.9 Channels

1 Flash channel	1
-----------------	---

10.10 Flash Code

Toshiba / Kioxia	TO
------------------	----

10.11 Temperature Option

Extended Temperature Range: -25 °C to 85 °C	E
Industrial Temperature Range: -40 °C to 85 °C	I

10.12 Die Classification

SLC MONO (single die package)	M
SLC DDP (dual die package)	D
SLC QDP (quad die package)	Q
SLC ODP (octal die package)	N

10.13 Pin Mode

Single nCE and Single R/nB	E
Dual nCE and Dual R/nB	F
Quad nCE and Quad R/nB	G

10.14 Configuration XYZ

X = Configuration

Configuration	X
UHS-I	2

Y = Firmware Revision

FW Revision	Y
Version 2	2

Z = Optional

Optional	Z
Optional	1

10.15 Option

Swissbit/Standard	STD
-------------------	-----

11. Marking specification

11.1 Front side



11.2 Back side marking



SWISSBIT
SFSDXXXLXAS1
TO-X-XX-XXX-STD
5021-6131210X
Made in Germany
CE WEEE

Part-
number
Calendar week and year – Lot code

Example of the back side laser marking

12. Revision History

Table 28: Document Revision History

Date	Revision	Description	Revision Details
13-April-2022	1.00	Initial release	Doc. req. no. 5366
22-April-2022	1.01	Adjusted Performance values of 512MB-2GB	Doc. req. no. 5380
15-August-2022	1.02	Updated to firmware "2"	Doc. req. no. 5678

Disclaimer:

No part of this document may be copied or reproduced in any form or by any means, or transferred to any third party, without the prior written consent of an authorized representative of Swissbit AG ("SWISSBIT"). The information in this document is subject to change without notice. SWISSBIT assumes no responsibility for any errors or omissions that may appear in this document, and disclaims responsibility for any consequences resulting from the use of the information set forth herein. SWISSBIT makes no commitments to update or to keep current information contained in this document. The products listed in this document are not suitable for use in applications such as, but not limited to, aircraft control systems, aerospace equipment, submarine cables, nuclear reactor control systems and life support systems. Moreover, SWISSBIT does not recommend or approve the use of any of its products in life support devices or systems or in any application where failure could result in injury or death. If a customer wishes to use SWISSBIT products in applications not intended by SWISSBIT, said customer must contact an authorized SWISSBIT representative to determine SWISSBIT willingness to support a given application. The information set forth in this document does not convey any license under the copyrights, patent rights, trademarks or other intellectual property rights claimed and owned by SWISSBIT. The information set forth in this document is considered to be "Proprietary" and "Confidential" property owned by SWISSBIT.

ALL PRODUCTS SOLD BY SWISSBIT ARE COVERED BY THE PROVISIONS APPEARING IN SWISSBIT'S TERMS AND CONDITIONS OF SALE ONLY, INCLUDING THE LIMITATIONS OF LIABILITY, WARRANTY AND INFRINGEMENT PROVISIONS. SWISSBIT MAKES NO WARRANTIES OF ANY KIND, EXPRESS, STATUTORY, IMPLIED OR OTHERWISE, REGARDING INFORMATION SET FORTH HEREIN OR REGARDING THE FREEDOM OF THE DESCRIBED PRODUCTS FROM INTELLECTUAL PROPERTY INFRINGEMENT, AND EXPRESSLY DISCLAIMS ANY SUCH WARRANTIES INCLUDING WITHOUT LIMITATION ANY EXPRESS, STATUTORY OR IMPLIED WARRANTIES OF MERCHANTABILITY OR FITNESS FOR A PARTICULAR PURPOSE.

©2022 SWISSBIT AG All rights reserved.