

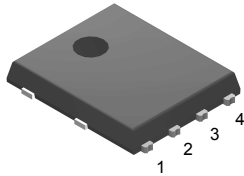
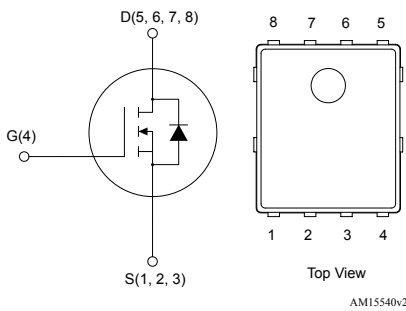

## Automotive N-channel enhancement mode logic level 40 V, 0.75 mΩ max., 373 A STripFET F8 Power MOSFET in a PowerFLAT 5x6

**PowerFLAT 5x6**

### Features

Order code	V <sub>DS</sub>	R <sub>DS(on)</sub> max.	I <sub>D</sub>
STL325N4LF8AG	40 V	0.75 mΩ	373 A

- AEC-Q101 qualified 
- MSL1 grade
- 175 °C operating temperature
- 100% avalanche tested
- Wettable flank package

### Applications

- Switching applications

### Description

This N-channel Power MOSFET utilizes STripFET F8 technology featuring an enhanced trench gate structure.

It ensures very low on-state resistance while reducing internal capacitances and gate charge for faster and more efficient switching.



#### Product status link

[STL325N4LF8AG](#)

#### Product summary

<b>Order code</b>	STL325N4LF8AG
<b>Marking</b>	325N4LF8
<b>Package</b>	PowerFLAT 5x6
<b>Packing</b>	Tape and reel

# 1 Electrical ratings

**Table 1. Absolute maximum ratings (at  $T_C = 25\text{ °C}$  unless otherwise specified)**

Symbol	Parameter	Value	Unit
$V_{DS}$	Drain-source voltage	40	V
$V_{GS}$	Gate-source voltage	$\pm 16$	V
$I_D^{(1)}$	Drain current (continuous) at $T_C = 25\text{ °C}$	373	A
	Drain current (continuous) at $T_C = 100\text{ °C}$	264	
$I_{DM}^{(1)(2)(3)}$	Drain current (pulsed), $t_p = 10\text{ }\mu\text{s}$	1492	A
$P_{TOT}$	Total power dissipation at $T_C = 25\text{ °C}$	188	W
$I_{AS}$	Single pulse avalanche current (pulse width limited by $T_J$ max.)	60	A
$E_{AS}$	Single pulse avalanche energy (starting $T_j = 25\text{ °C}$ , $I_D = 60\text{ A}$ , $R_{Gmin} = 25\text{ }\Omega$ )	590	mJ
$T_j$	Operating junction temperature range	-55 to 175	°C
$T_{stg}$	Storage temperature range		

1. The value is relevant to  $R_{thJC}$ . Current limitations will come from the operative conditions, such as temperature and thermal resistance of the PCB.
2. Specified by design and evaluated by characterization, not tested in production.
3. Pulse width is limited by safe operating area.

**Table 2. Thermal data**

Symbol	Parameter	Value	Unit
$R_{thJA}^{(1)}$	Thermal resistance, junction-to-ambient (on 2s2p FR-4 board vertical in still area)	20	°C/W
$R_{thJC}$	Thermal resistance, junction-to-case	0.8	°C/W

1. Defined according to JEDEC standards (JESD51-5, -7).

## 2 Electrical characteristics

$T_J = 25\text{ °C}$  unless otherwise specified.

**Table 3. On/off states**

Symbol	Parameter	Test conditions	Min.	Typ.	Max.	Unit
$V_{(BR)DSS}$	Drain-source breakdown voltage	$V_{GS} = 0\text{ V}, I_D = 1\text{ mA}$	40			V
$I_{DSS}$	Zero gate voltage drain current	$V_{DS} = 40\text{ V}, V_{GS} = 0\text{ V}$			1	$\mu\text{A}$
		$V_{DS} = 40\text{ V}, V_{GS} = 0\text{ V},$ $T_J = 125\text{ °C}$ <sup>(1)</sup>			100	
$I_{GSS}$	Gate-body leakage current	$V_{GS} = 20\text{ V}, V_{DS} = 0\text{ V}$			100	nA
$V_{GS(th)}$	Gate threshold voltage	$V_{DS} = V_{GS}, I_D = 250\text{ }\mu\text{A}$	1.2		2.0	V
$R_{DS(on)}$	Static drain-source on-resistance	$V_{GS} = 10\text{ V}, I_D = 60\text{ A}$		0.55	0.75	m $\Omega$
		$V_{GS} = 4.5\text{ V}, I_D = 60\text{ A}$		0.85	1.1	

1. Specified by design and evaluated by characterization, not tested in production.

**Table 4. Dynamic**

Symbol	Parameter	Test conditions	Min.	Typ.	Max.	Unit
$C_{iss}$ <sup>(1)</sup>	Input capacitance	$V_{DS} = 25\text{ V}, f = 1\text{ MHz}, V_{GS} = 0\text{ V}$	-	7657	-	pF
$C_{oss}$ <sup>(1)</sup>	Output capacitance		-	1968	-	pF
$C_{riss}$ <sup>(1)</sup>	Reverse transfer capacitance		-	50	-	pF
$Q_g$ <sup>(1)</sup>	Total gate charge	$V_{DD} = 20\text{ V}, I_D = 120\text{ A}, V_{GS} = 0\text{ to }4.5\text{ V}$	-	39	-	nC
		$V_{DD} = 20\text{ V}, I_D = 120\text{ A}, V_{GS} = 0\text{ to }10\text{ V}$	-	95	-	
$Q_{gs}$ <sup>(1)</sup>	Gate-source charge	$V_{DD} = 20\text{ V}, I_D = 120\text{ A}, V_{GS} = 0\text{ to }4.5\text{ V}$	-	23	-	nC
$Q_{gd}$ <sup>(1)</sup>	Gate-drain charge		-	6	-	nC

1. Specified by design and evaluated by characterization, not tested in production.

**Table 5. Switching times**

Symbol	Parameter	Test conditions	Min.	Typ.	Max.	Unit
$t_{d(on)}$ <sup>(1)</sup>	Turn-on delay time	$V_{DD} = 20\text{ V}, I_D = 60\text{ A},$ $R_G = 4.7\text{ }\Omega, V_{GS} = 10\text{ V}$	-	12.5	-	ns
$t_r$ <sup>(1)</sup>	Rise time		-	6.5	-	ns
$t_{d(off)}$ <sup>(1)</sup>	Turn-off delay time		-	89	-	ns
$t_f$ <sup>(1)</sup>	Fall time		-	21	-	ns

1. Specified by design and evaluated by characterization, not tested in production.

**Table 6. Source-drain diode**

Symbol	Parameter	Test conditions	Min.	Typ.	Max.	Unit
$I_{SD}^{(1) (2)}$	Forward on current (continuous)	$T_C = 25\text{ }^\circ\text{C}$	-		135	A
$V_{SD}$	Forward on voltage	$I_{SD} = 60\text{ A}, V_{GS} = 0\text{ V}$	-		1.1	V
$t_{rr}^{(1)}$	Reverse recovery time	$I_D = 60\text{ A}, di/dt = 100\text{ A}/\mu\text{s}, V_{DD} = 32\text{ V}$	-	60.1		ns
$Q_{rr}^{(1)}$	Reverse recovery charge		-	74.4		nC
$I_{RRM}^{(1)}$	Reverse recovery current		-	2.5		A

1. Specified by design and evaluated by characterization, not tested in production.
2. The value is relevant to  $R_{thJC}$ . Current limitations will come from the operating conditions, such as temperature and thermal resistance of the PCB.

## 2.1 Electrical characteristics (curves)

Figure 1. Total power dissipation

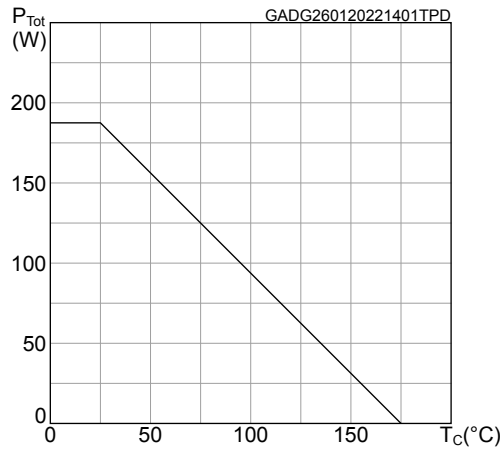

Figure 2. Drain current vs case temperature

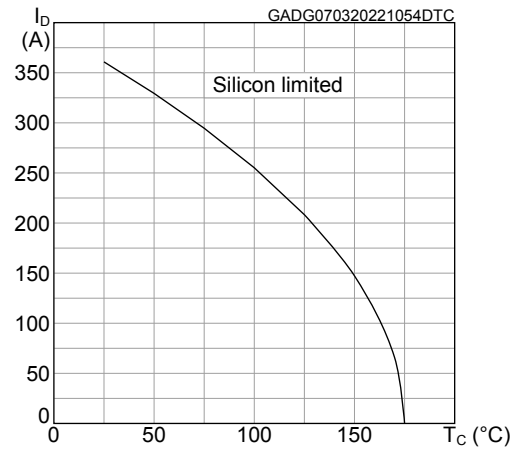

Figure 3. Safe operating area

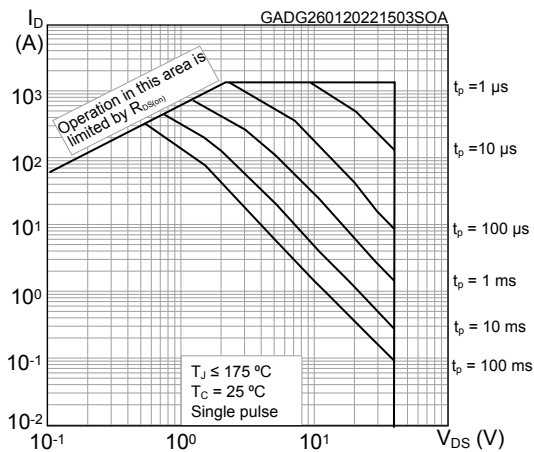

Figure 4. Normalized transient thermal impedance

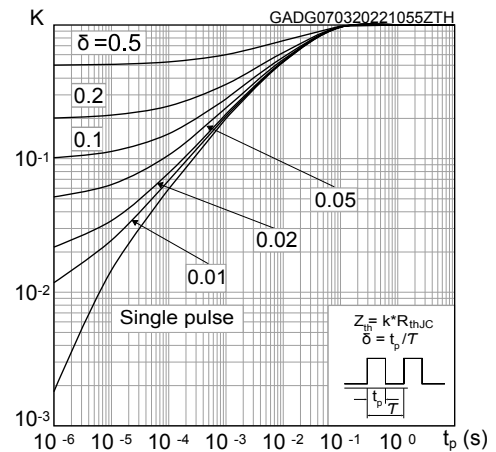

Figure 5. Typical output characteristics

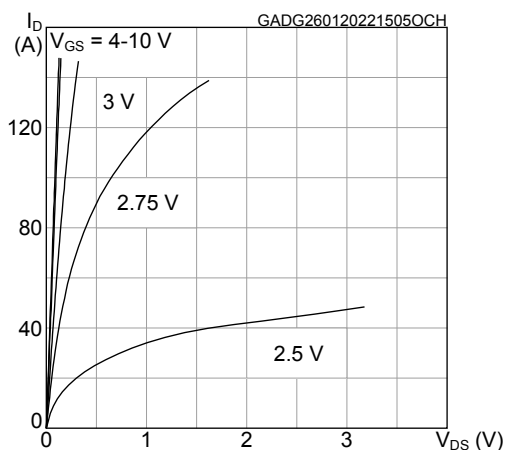
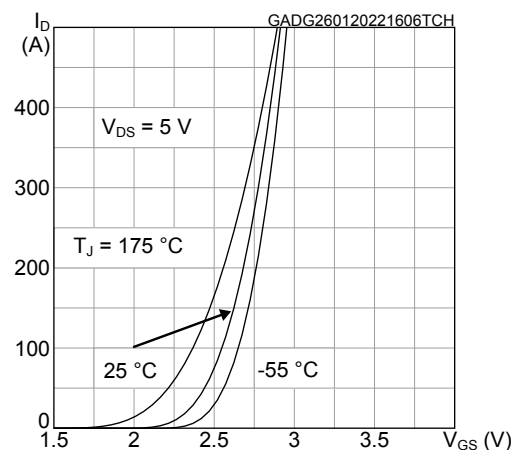
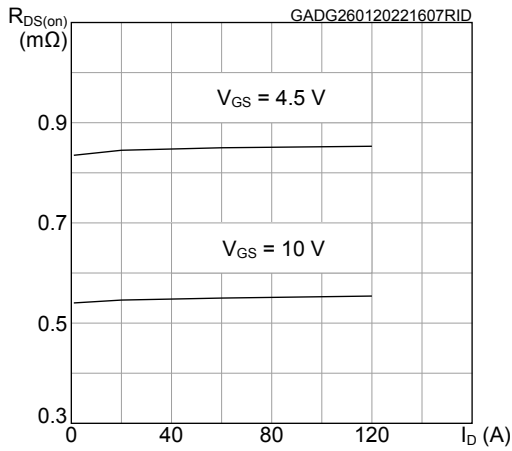

Figure 6. Typical transfer characteristics



**Figure 7. Typical drain-source on-resistance**



**Figure 8. Typical on-resistance vs gate-source voltage**

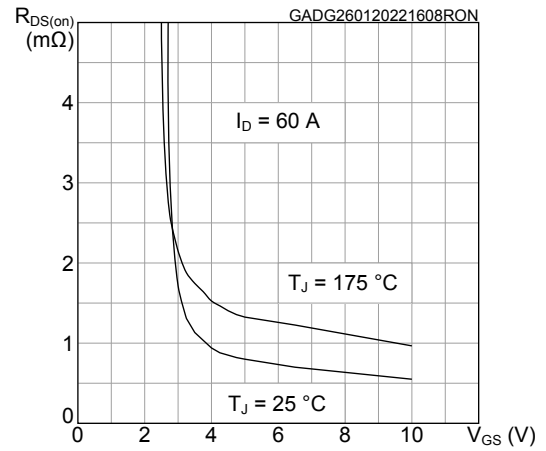

**Figure 9. Typical gate charge characteristics**

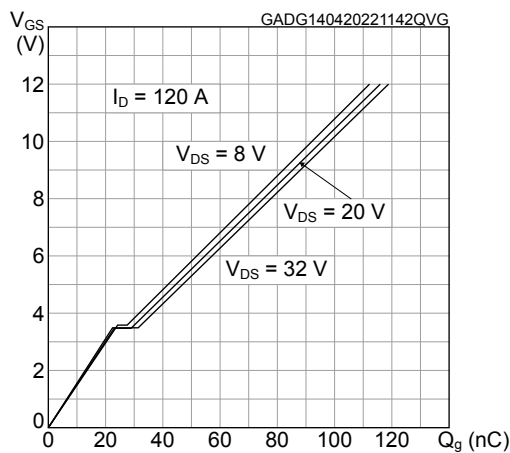

**Figure 10. Typical capacitance characteristics**

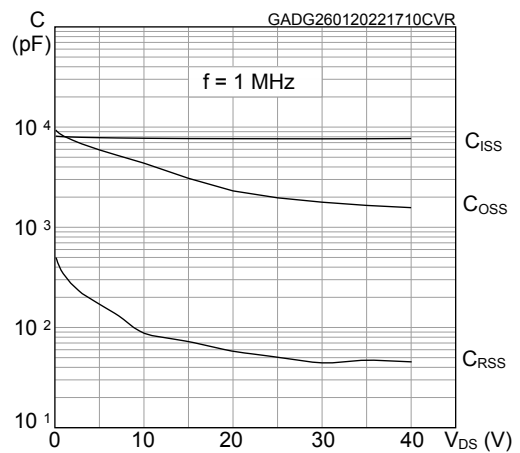

**Figure 11. Avalanche characteristics**

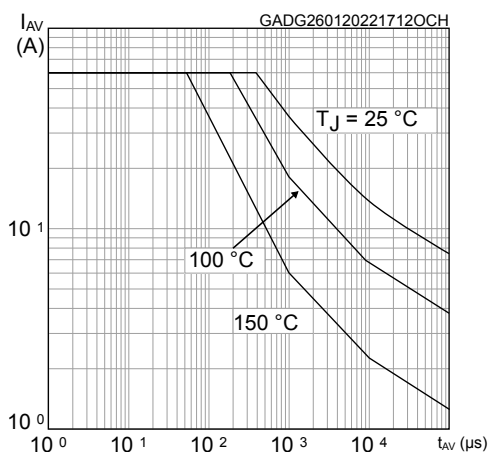

**Figure 12. Avalanche energy**

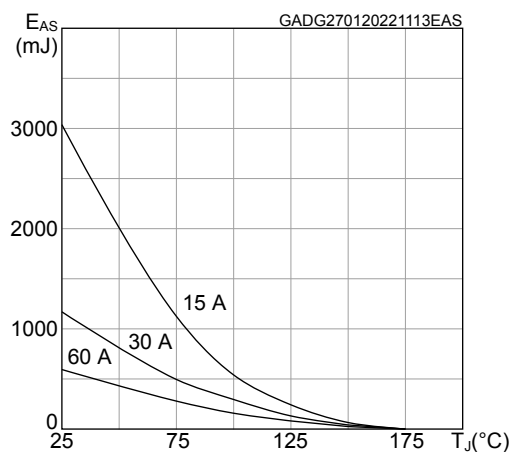

Figure 13. Typical reverse diode forward characteristics

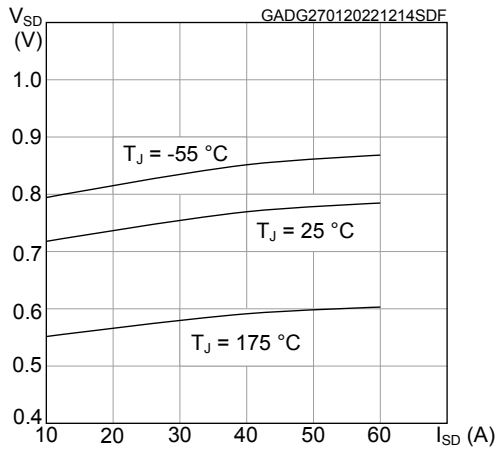

Figure 14. Normalized on-resistance vs temperature

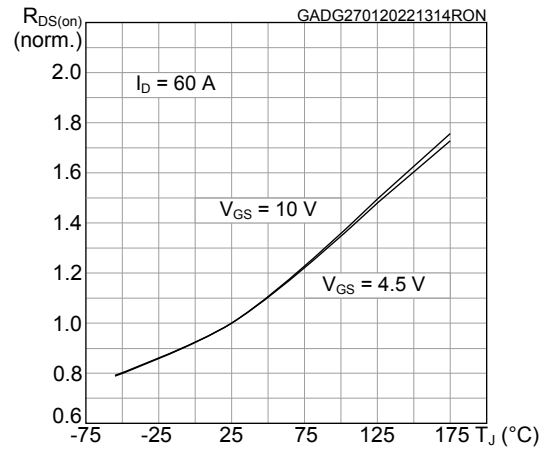

Figure 15. Normalized gate threshold voltage vs temperature

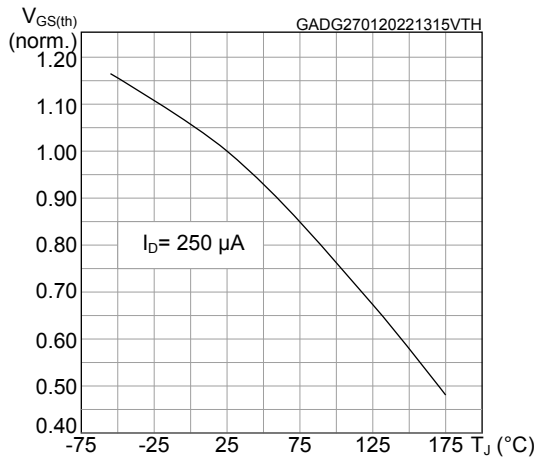
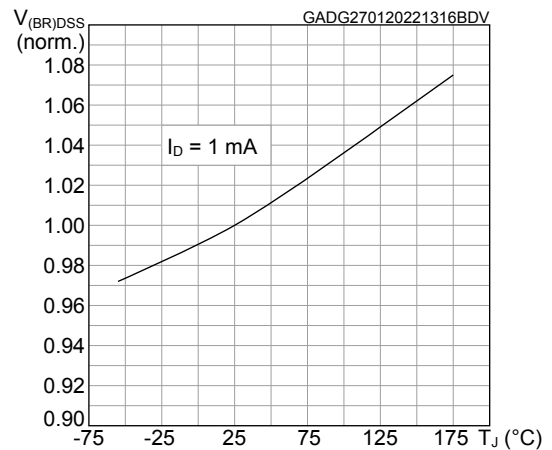

Figure 16. Normalized  $V_{(BR)DSS}$  vs temperature



### 3 Package information

In order to meet environmental requirements, ST offers these devices in different grades of **ECOPACK** packages, depending on their level of environmental compliance. ECOPACK specifications, grade definitions and product status are available at: [www.st.com](http://www.st.com). ECOPACK is an ST trademark.

#### 3.1 PowerFLAT 5x6 WF type C package information

Figure 17. PowerFLAT 5x6 WF type C package outline

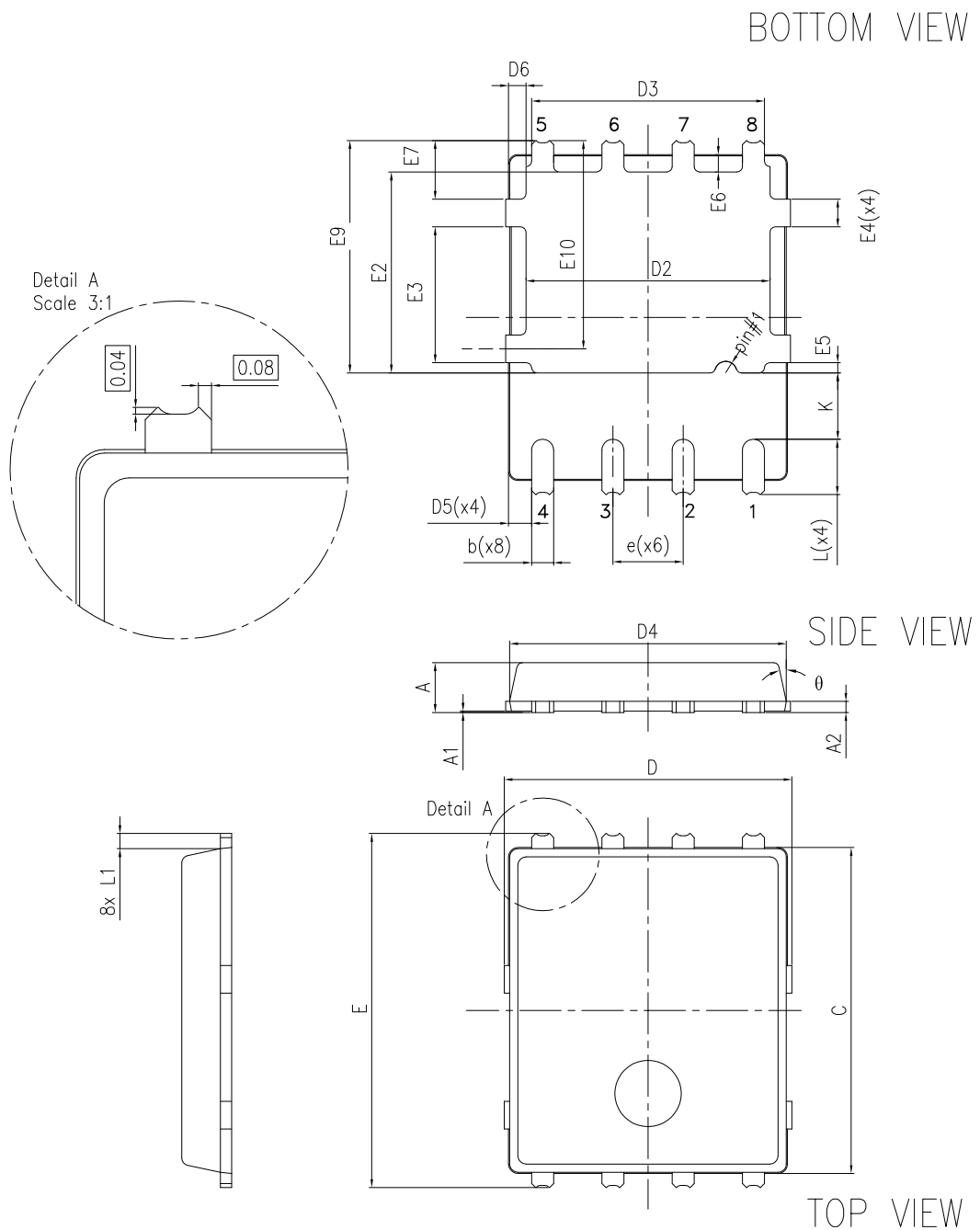

8231817\_WF\_typeC\_r20

**Table 7. PowerFLAT 5x6 WF type C mechanical data**

Dim.	mm		
	Min.	Typ.	Max.
A	0.80		1.00
A1	0.00		0.05
A2		0.25	
b	0.30		0.50
C	5.80	6.00	6.10
D	5.00	5.20	5.40
D2	4.15		4.45
D3	4.05	4.20	4.35
D4	4.80	5.00	5.10
D5	0.25	0.40	0.55
D6	0.15	0.30	0.45
e		1.27	
E	6.20	6.40	6.60
E2	3.50		3.70
E3	2.35		2.55
E4	0.40		0.60
E5	0.08		0.28
E6	0.20	0.325	0.45
E7	0.85	1.00	1.15
E9	4.00	4.20	4.40
E10	3.55	3.70	3.85
K	1.05		1.35
L	0.90	1.00	1.10
L1	0.175	0.275	0.375
θ	0°		12°

Figure 18. PowerFLAT 5x6 recommended footprint (dimensions are in mm)

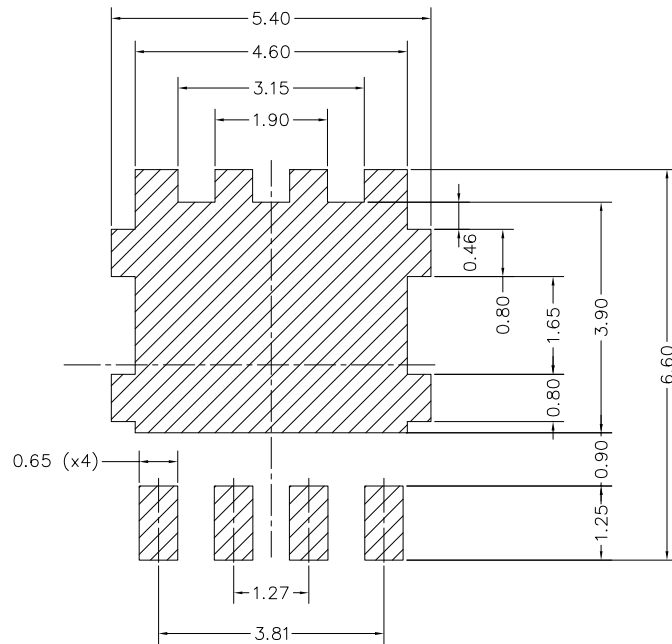

8231817\_FOOTPRINT\_rev20

### 3.2 PowerFLAT 5x6 packing information

Figure 19. PowerFLAT 5x6 tape (dimensions are in mm)

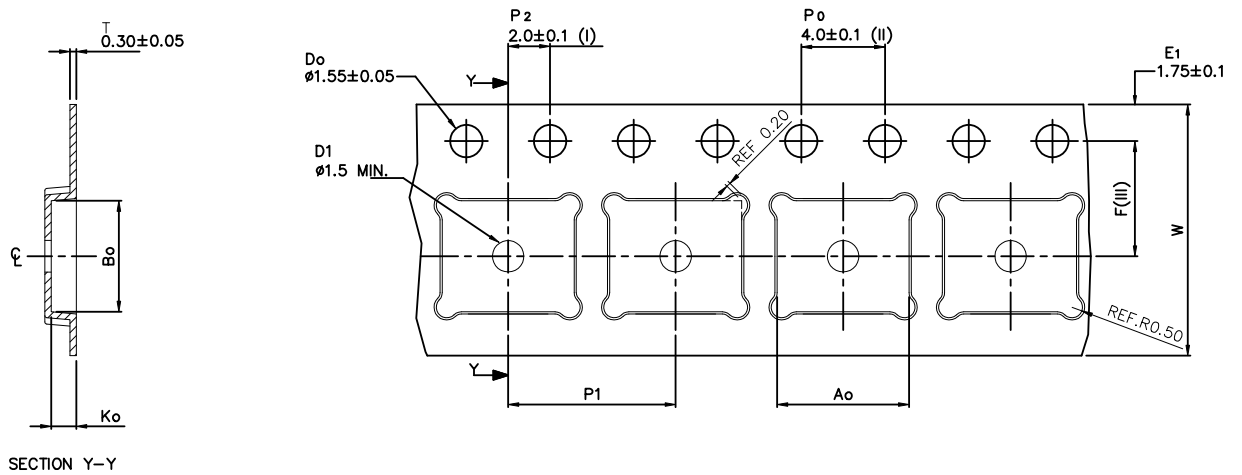

SECTION Y-Y

Ao	6.30	+/-	0.1
Bo	5.30	+/-	0.1
Ko	1.20	+/-	0.1
F	5.50	+/-	0.1
P1	8.00	+/-	0.1
W	12.00	+/-	0.3

- (I) Measured from centreline of sprocket hole to centreline of pocket.
- (II) Cumulative tolerance of 10 sprocket holes is  $\pm 0.20$ .
- (III) Measured from centreline of sprocket hole to centreline of pocket

Base and bulk quantity 3000 pcs  
All dimensions are in millimeters

8234350\_Tape\_rev\_C

**Figure 20. PowerFLAT 5x6 package orientation in carrier tape**

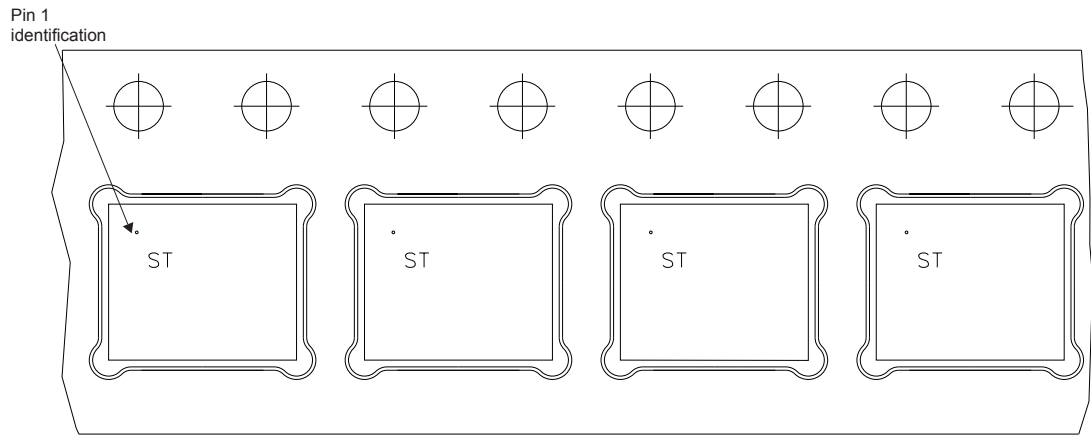

**Figure 21. PowerFLAT 5x6 reel**

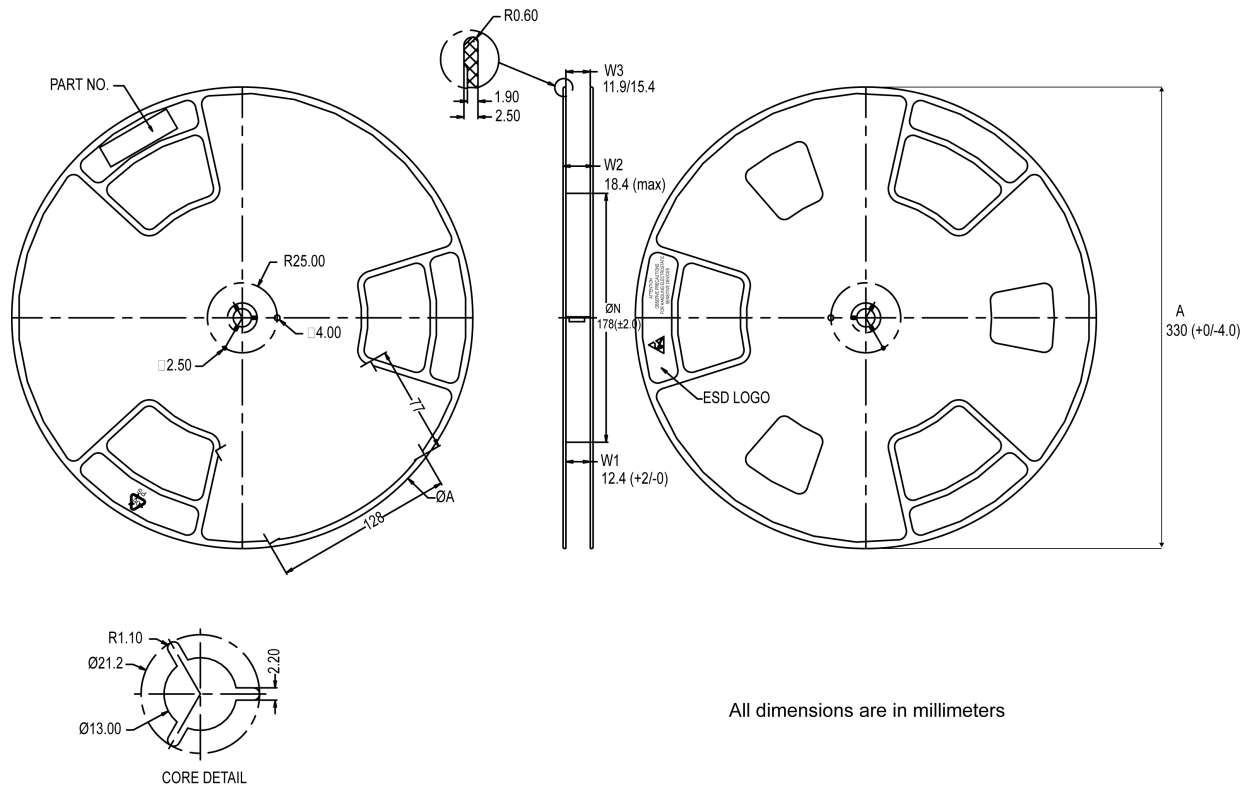

All dimensions are in millimeters

8234350\_Reel\_rev\_C

### 3.3 PowerFLAT 5x6 marking information

Figure 22. PowerFLAT 5x6 marking information

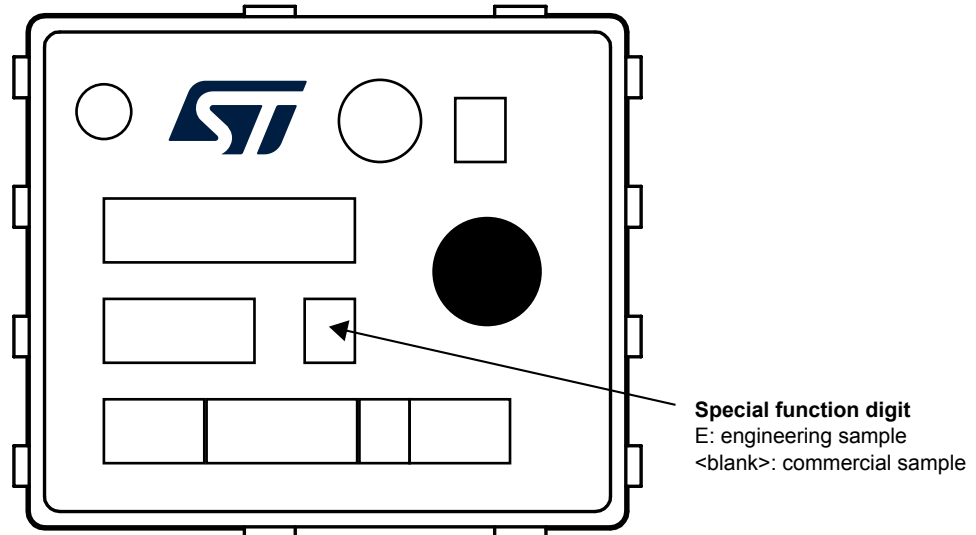

**Note:** *Engineering Samples: these samples can be clearly identified by a dedicated special symbol in the marking of each unit. These samples are intended to be used for electrical compatibility evaluation only; usage for any other purpose may be agreed only upon written authorization by ST. ST is not liable for any customer usage in production and/or in reliability qualification trials.*

Commercial Samples: fully qualified parts from ST standard production with no usage restrictions.

## Revision history

**Table 8. Document revision history**

Date	Revision	Changes
27-Apr-2022	1	Initial release.

---

## Contents

<b>1</b>	<b>Electrical ratings</b> .....	<b>2</b>
<b>2</b>	<b>Electrical characteristics</b> .....	<b>3</b>
<b>2.1</b>	Electrical characteristics (curves) .....	<b>5</b>
<b>3</b>	<b>Package information</b> .....	<b>8</b>
<b>3.1</b>	[Package name] package information .....	<b>8</b>
<b>3.2</b>	PowerFLAT 5x6 packing information .....	<b>10</b>
<b>3.3</b>	PowerFLAT 5x6 marking information .....	<b>12</b>
	<b>Revision history</b> .....	<b>13</b>
	<b>Contents</b> .....	<b>14</b>

**IMPORTANT NOTICE – READ CAREFULLY**

STMicroelectronics NV and its subsidiaries (“ST”) reserve the right to make changes, corrections, enhancements, modifications, and improvements to ST products and/or to this document at any time without notice. Purchasers should obtain the latest relevant information on ST products before placing orders. ST products are sold pursuant to ST’s terms and conditions of sale in place at the time of order acknowledgment.

Purchasers are solely responsible for the choice, selection, and use of ST products and ST assumes no liability for application assistance or the design of purchasers’ products.

No license, express or implied, to any intellectual property right is granted by ST herein.

Resale of ST products with provisions different from the information set forth herein shall void any warranty granted by ST for such product.

ST and the ST logo are trademarks of ST. For additional information about ST trademarks, refer to [www.st.com/trademarks](http://www.st.com/trademarks). All other product or service names are the property of their respective owners.

Information in this document supersedes and replaces information previously supplied in any prior versions of this document.

© 2022 STMicroelectronics – All rights reserved