

Ultralow noise, wide bandwidth, 3-axis accelerometer with TDM interface for automotive applications



LGA-14L
2.5 x 2.5 x 0.86 mm³

Product status link

[AIS25BA](#)

Product summary

Order code	AIS25BATR
Temp. range [°C]	-40 to +125
Package	LGA-14L 2.5 x 2.5 x 0.86 mm ³
Packaging	Tape and reel

Product resources

[TN0018](#) (Design and soldering)

Product label



Features

- AEC-Q100 qualified 
- 3-axis accelerometer with user-selectable full-scale: $\pm 3.85/\pm 7.7$ g
- Wide and flat frequency response: from dc up to 2.4 kHz (typ)
- Low latency (entire reading chain): 266 μ s @ 2 kHz (typ)
- Ultralow noise density (typ: 30 μ g/ $\sqrt{\text{Hz}}$ for X and Y axes; 50 μ g/ $\sqrt{\text{Hz}}$ for Z-axis)
- TDM (8/16/24 kHz) slave interface for sensor data and I²C interface for configuration
- Supply voltage: 1.71 V to 2.1 V
- Extended temperature range from -40 °C to +125 °C
- Embedded self-test
- Compact package: LGA 2.5 x 2.5 x 0.86 mm 14-lead
- 10000 g high shock survivability
- Lead-free, **ECOPACK** and RoHS compliant

Applications

- Wideband active noise control (ANC)
- Vibration monitoring

Description

The AIS25BA is an ultralow noise, low latency, wide bandwidth, 3-axis digital accelerometer with a dedicated TDM interface designed to address automotive non-safety applications, in particular, wideband active noise control (ANC) and vibration monitoring.

The AIS25BA has a user-selectable full-scale range of $\pm 3.85/\pm 7.7$ g, a time-division multiplexing (TDM) interface for the sensor data, and an I²C interface for device configuration.

The AIS25BA is available in a small thin plastic land grid array package (LGA) and is guaranteed to operate over an extended temperature range from -40 °C to +125 °C.

1 Pin description

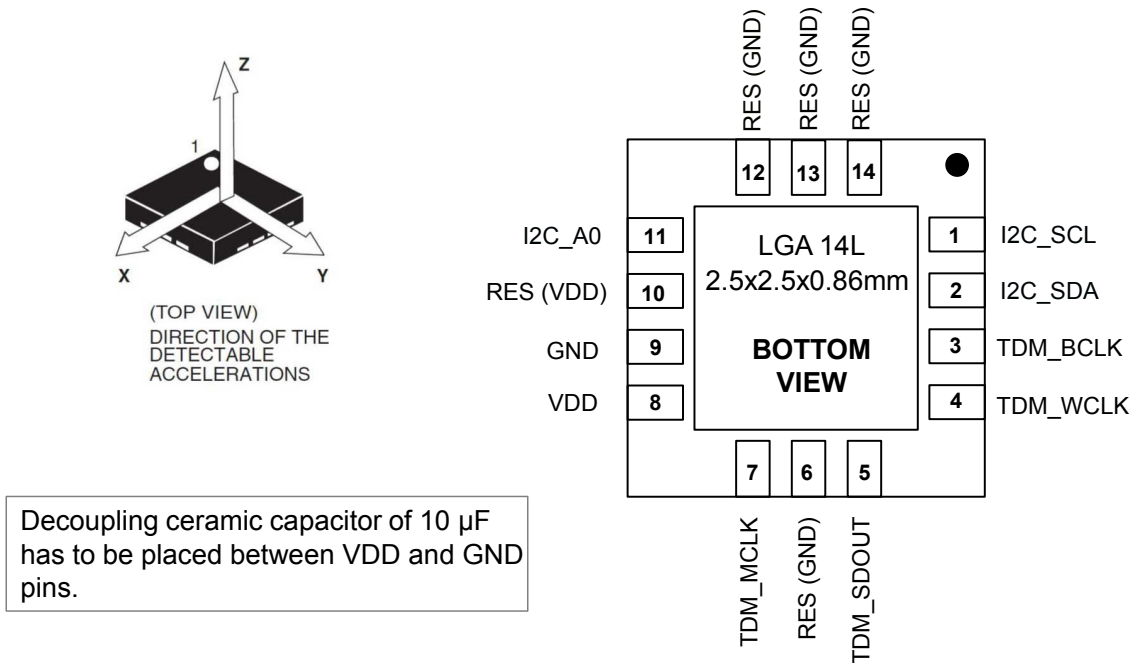
Figure 1. Pin connections

Table 1. Pin description

Pin#	Name	IN/OUT	Function
1	I2C_SCL	IN	I ² C serial clock - SCL
2	I2C_SDA	IN/OUT	I ² C serial data - SDA
3	TDM_BCLK	IN	TDM bit clock
4	TDM_WCLK	IN	TDM word clock
5	TDM_SDOOUT	OUT	TDM serial data output
6	RES (GND)	-	Reserved pin (connect to GND)
7	TDM_MCLK	IN	TDM master clock
8	VDD		Power supply
9	GND		0 V supply
10	RES (VDD)	-	Reserved pin (connect to VDD)
11	I2C_A0	IN	I ² C slave address selection
12	RES (GND)	-	Reserved pin (connect to GND)
13	RES (GND)	-	Reserved pin (connect to GND)
14	RES (GND)	-	Reserved pin (connect to GND)

2 Mechanical and electrical specifications

2.1 Mechanical characteristics

@ V_{dd} = 1.8 V, temperature from -40 °C to +125 °C unless otherwise noted.

The product is factory calibrated at 1.8 V. The operational power supply range is from 1.71 V to 2.1 V.

Table 2. Mechanical characteristics

Symbol	Parameter	Test conditions	Min.	Typ. ⁽¹⁾	Max.	Unit
FS	Measurement range			3.85		g
				7.7		
So	Nominal sensitivity ⁽²⁾	@ FS ±3.85 g @ 25 °C		0.122		mg/LSB
		@ FS ±3.85 g @ 25 °C		-11.71		dBFS/g
		@ FS ±7.7 g @ 25 °C		0.244		mg/LSB
		@ FS ±7.7 g @ 25 °C		-17.73		dBFS/g
So %	Sensitivity tolerance ⁽²⁾	@ T = 25 °C	-9		+9	%
	Sensitivity tolerance - long term	Long term includes post solder, drift in temperature in the range [-40°C to +125 °C] and over life	-15		+15	
TCS _o	Sensitivity change vs. temperature ⁽³⁾	From -40 to +125 °C, delta from 25 °C		±0.015		%/°C
TyOff	Zero-g level offset accuracy ⁽²⁾	@ T = 25 °C	-180		+180	mg
Off	Zero-g level offset accuracy - long term	Long term includes post solder, drift in temperature in the range [-40°C to +125 °C] and over life	-800		+800	mg
TCOff	Zero-g level change vs. temperature ⁽³⁾	From -40 to +125 °C, delta from 25 °C		4		mg/°C
An	Acceleration electrical noise	BW = 2.4 kHz @ T = 25 °C X, Y-axis			1.6	mg rms
		BW = 2.4 kHz @ T = 25 °C Z-axis			2.4	
An _{tot}	Acceleration noise density ⁽⁴⁾	@ T = 25 °C X, Y-axis		30		µg/√Hz
		@ T = 25 °C Z-axis		50		µg/√Hz
BW	Signal bandwidth	@ T = 25 °C	2200	2400		Hz
LAT	Latency ⁽⁵⁾	Including the full chain @ 2 kHz; TDM @ 16 kHz @ T = 25 °C		266		µs
NL	Non-linearity ⁽⁶⁾	@FS ±7.7 g; -7.4 g < input acceleration [g] < +7.4 g @ T = 25 °C	-0.5		+0.5	%FS
Cx	Cross-axis sensitivity ⁽⁶⁾	@ FS ±3.85 g, @ 25 °C		±1		%
RFm	Mechanical resonant frequency of the MEMS element ⁽⁵⁾	X-axis, @ T = 25 °C		5150		Hz
		Y-axis, @ T = 25 °C		5150		Hz
		Z-axis, @ T = 25 °C		4950		Hz
ST	Self-test deviation ⁽⁷⁾	X-axis, from -40 to +125 °C	300		1000	mg
		Y-axis, from -40 to +125 °C	300		1000	mg
		Z-axis, from -40 to +125 °C	500		2700	mg

1. Typical specifications are not guaranteed.

2. Values after factory calibration test and trimming at $T = 25\text{ }^{\circ}\text{C}$.
3. Based on characterization results on a limited number of samples, not tested in production and not guaranteed.
4. Includes Brownian noise. Based on characterization results at 3σ on a limited number of samples, not tested in production and not guaranteed.
5. Specified by design, not tested in production and not guaranteed.
6. Based on characterization results at 3σ on a limited number of samples, not tested in production and not guaranteed.
7. This is the difference between the output in self-test mode and the output in normal mode.

2.2 Electrical characteristics

@ $V_{dd} = 1.8\text{ V}$, temperature from $-40\text{ }^{\circ}\text{C}$ to $+125\text{ }^{\circ}\text{C}$ unless otherwise noted.

The product is factory calibrated at 1.8 V. The operational power supply range is from 1.71 V to 2.1 V.

Table 3. Electrical characteristics

Symbol	Parameter	Test conditions	Min.	Typ. ⁽¹⁾	Max.	Unit
Vdd	Supply voltage		1.71	1.8	2.1	V
Idd	Current consumption in normal mode	Three axes enabled			5.0	mA
Idd_PD	Current consumption in power-down mode	@ $T = 25\text{ }^{\circ}\text{C}$			1	μA
ODR	Output data rate	TDM @ 8 kHz		8		kHz
		TDM @ 16 kHz		16		kHz
		TDM @ 24 kHz		24		kHz
VIH	Digital high-level input voltage		$0.7 \cdot V_{dd}$			V
VIL	Digital low-level input voltage				$0.3 \cdot V_{dd}$	V
VOH	High-level output voltage	$I_{OH} = 2\text{ mA}^{(2)}$	$V_{dd} - 0.2$			V
VOL	Low-level output voltage	$I_{OL} = 2\text{ mA}^{(2)}$			0.2	V
Top	Operating temperature range		-40		+125	$^{\circ}\text{C}$

1. Typical specifications are not guaranteed.
2. 2 mA is the maximum driving capability, that is, the maximum DC current that can be sourced/sunk by the digital pad in order to guarantee the correct digital output voltage levels VOH and VOL.

2.3 Absolute maximum ratings

Stresses above those listed as “absolute maximum ratings” may cause permanent damage to the device. This is a stress rating only and functional operation of the device under these conditions is not implied. Exposure to maximum rating conditions for extended periods may affect device reliability.

Table 4. Absolute maximum ratings

Symbol	Ratings	Maximum value	Unit
V _{DD}	Supply voltage	-0.3 to 4.8	V
STR	Storage temperature range	-40 to +150	°C
A _{UNP}	Acceleration (any axis, unpowered)	10,000 g for 0.2 ms	g
		3000 g for 0.3 ms	
EDP	Electrostatic discharge protection (HBM)	2	kV
V _{MAX}	Maximum input voltage on all input pins	4.8	V
V _{MIN}	Minimum input voltage on all input pins	-0.3	V
I _{IN}	Input current on all I/O pins (does not cause SCR latch-up)	±10	mA

Note: Supply voltage on any pin should never exceed 4.8 V.



This device is sensitive to mechanical shock, improper handling can cause permanent damage to the part.



This device is sensitive to electrostatic discharge (ESD), improper handling can cause permanent damage to the part.

3 TDM interface characteristics

All setup times and hold times in Table 5 and in Figure 2 are valid for BCLK polarity set to “clock on rising”. If BCLK polarity is set to “clock on falling”, then all setup and hold times will refer to the falling edge of BCLK instead. Please refer to Section 4 TDM interface specifications for additional details.

Table 5. TDM interface characteristics

Symbol	Parameter	Test conditions	Min.	Typ.	Max.	Unit
MCLK	MCLK frequency nominal			12.288		MHz
MCLKA	MCLK frequency accuracy		-0.1		0.1	%
MCLKJ	MCLK jitter				1	ns (peak to peak)
BCLK	BCLK frequency (1/tp)	in disabled mode			MCLK	MHz
		WCLK = 8 kHz		1.024		MHz
		WCLK = 16 kHz		2.048		MHz
		WCLK = 24 kHz		3.072		MHz
WCLK8	8 kHz WCLK mode		8		kHz	
WCLK16	16 kHz WCLK mode		16			
WCLK24	24 kHz WCLK mode		24			
PDC	All clock pin duty cycle (except WCLK)		45		55	%
WT	WCLK setup time before BCLK rising/falling edge (tss1)		20			ns
SDOST	SDOUT setup time before BCLK rising/falling edge (tss2)		15			ns
SDOHTR	SDOUT hold time after BCLK rising/falling edge (ths1)		15			ns
SDOHTZ	SDOUT hold time of LSB after BCLK rising/falling edge (ths2)		15		50	ns
C _{MCLK}	MCLK pin capacitance				10	pF
C _{BCLK}	BCLK pin capacitance				10	
C _{WCLK}	WCLK pin capacitance				10	
C _{SDOUT}	SDOUT load capacitance				60	
FR _{REL}	Relative frequency response ⁽¹⁾	⁽²⁾	-0.5		0.4	dB

1. Data by simulation

2. All the DUT measurement points are normalized to the 294 Hz measurement. The deviation between each point and 294 Hz is calculated. The maximum deviation for points measured at frequencies below 2.0 kHz is given as FR_{REL}.

Figure 2. TDM interface characteristics

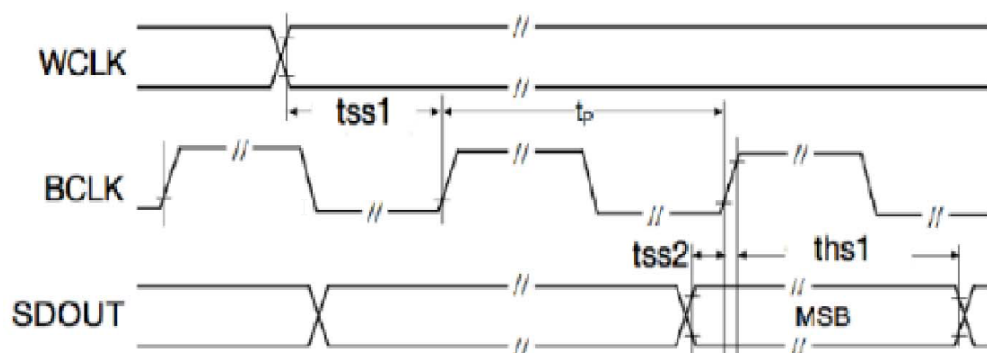

3.1 I²C interface characteristics

Refer to [Section 5 I²C- inter-IC control interface](#) for additional details.

The data in the following table are based on standard I²C protocol requirements. Values are not tested in production and are not guaranteed. The I²C interface can be used only to access the registers of the device for configuration purposes, but not for reading accelerometer data.

Table 6. Digital input/output voltage for I²C pins

Symbol	Parameter	Test conditions	Min.	Typ. ⁽¹⁾	Max.	Unit
V _{IH}	Digital high-level input voltage		0.7*V _{dd}			V
V _{IL}	Digital low-level input voltage				0.3*V _{dd}	V
V _{OL}	Low-level output voltage	I _{OL} = 2 mA ⁽²⁾	0.2			V

1. Typical specifications are not guaranteed.
2. 2 mA is the maximum driving capability, that is, the maximum DC current that can be sourced/sunk by the digital pad in order to guarantee the correct digital output voltage levels V_{OH} and V_{OL}.

Table 7. I²C interface characteristics

Symbol	Parameter	Test conditions	Min.	Typ. ⁽¹⁾	Max.	Unit
f _(SCL)	SCL		96		400	kHz
C _{SDA-N}	SDA/SCL bus capacitance normal mode	R _{SDA} = 2.5 kOhm			150	pF
C _{SDA-HS}	SDA/SCL bus capacitance high-speed mode	R _{SDA} = 2.5 kOhm			50	pF
R _{SDA}	SDA/SCL pull-up resistance		2500			Ohm
t _{w(SCLL)}	SCL clock low time		1.3			μs
t _{w(SCLH)}	SCL clock high time		0.6			
t _{su(SDA)}	SDA setup time		100			ns
t _{h(SDA)}	SDA data hold time		0		0.9	μs
t _{h(ST)}	Start condition hold time		0.6			
t _{su(SR)}	Repeated start condition setup time		0.6			
t _{su(SP)}	Stop condition setup time		0.6			
t _{w(SP:SR)}	Bus free time between stop and start condition		1.3			
I2C_HYST	SDA/SCL minimum pulse width hysteresis				50	ns

1. Typical specifications are not guaranteed.

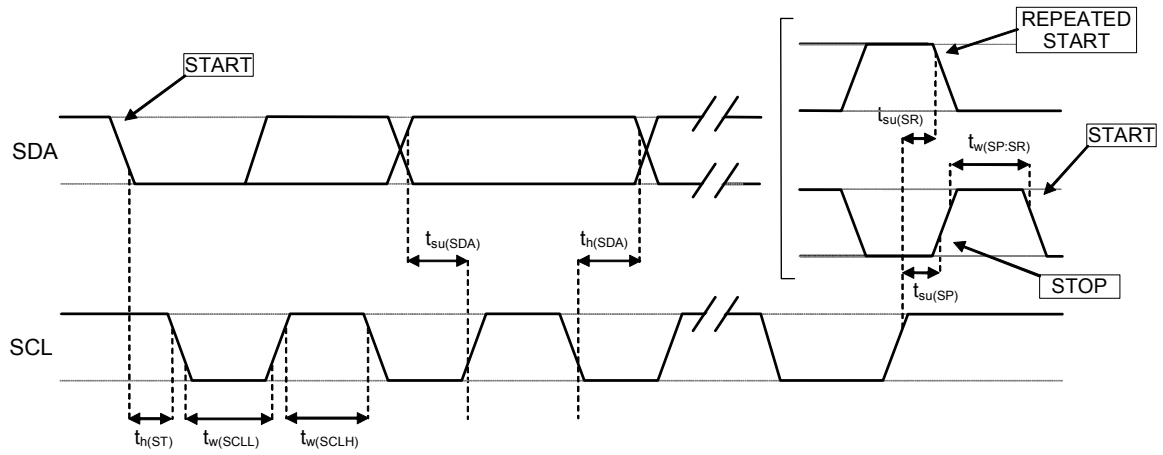
Figure 3. I²C slave timing diagram

Note: Measurement points are done at $0.3 \cdot V_{dd}$ and $0.7 \cdot V_{dd}$ for both ports.

Table 8. I²C high-speed mode specifications at 1 MHz

	Symbol	Parameter	Min	Max	Unit	
Fast mode plus ⁽¹⁾	f_{SCL}	SCL clock frequency	0	1	MHz	
	$t_{HD;STA}$	Hold time (repeated) START condition	260	-	ns	
	t_{LOW}	Low period of the SCL clock	500	-		
	t_{HIGH}	High period of the SCL clock	260	-		
	$t_{SU;STA}$	Setup time for a repeated start condition	260	-		
	$t_{HD;DAT}$	Data hold time	0	-		
	$t_{SU;DAT}$	Data setup time	50	-		
	t_{rDA}	Rise time of SDA signal	-	120		
	t_{fDA}	Fall time of SDA signal	-	120		
	t_{rCL}	Rise time of SCL signal	$20 \cdot V_{dd} / 5.5$	120		
	t_{fCL}	Fall time of SCL signal	$20 \cdot V_{dd} / 5.5$	120		
	$t_{SU;STO}$	Setup time for stop condition	260	-		
	C_b	Capacitive load for each bus line	-	550		pF
	$t_{VD;DAT}$	Data valid time	-	450		ns
	$t_{VD;ACK}$	Data valid acknowledge time	-	450		
	V_{nL}	Noise margin at low level	$0.1V_{dd}$	-	V	
	V_{nH}	Noise margin at high level	$0.2V_{dd}$	-		
t_{SP}	Pulse width of spikes that must be suppressed by the input filter	0	50	ns		

1. Data based on characterization, not tested in production

4 TDM interface specifications

Time-division multiplexing (TDM) is a method of putting multiple data streams in one data signal by separating the signal into many frames. There are many ways to accomplish this.

4.1 TDM interface overview

The block diagram of the TDM interface implemented in the AIS25BA device is illustrated in the following figure.

Figure 4. TDM block diagram

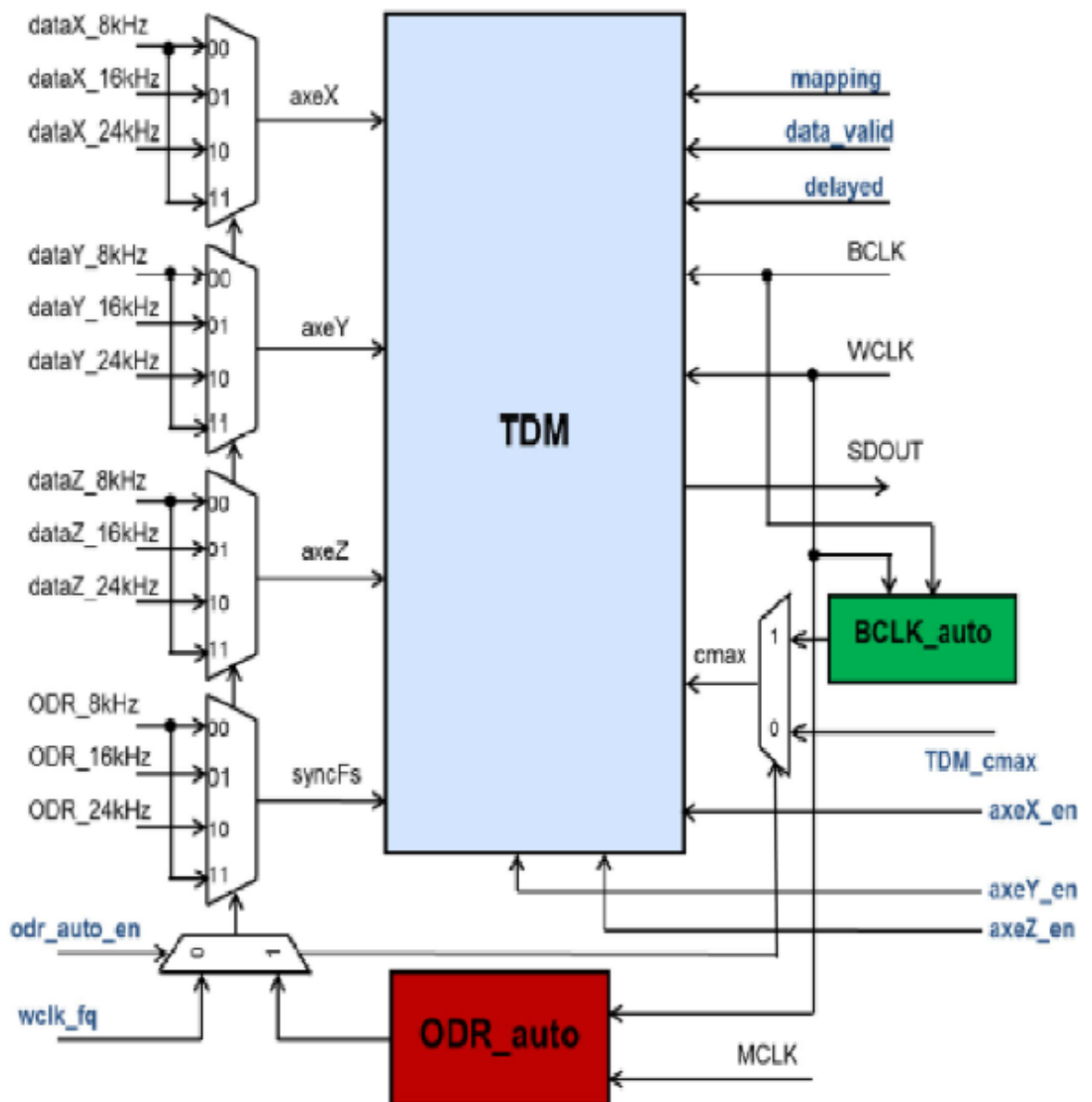

As depicted in the figure above, the TDM interface is comprised of two control clocks, a frame synchronization (WCLK) a serial clock (BCLK), and the serial data out (SDOUT).

4.2 Frame synchronization (WCLK)

The function of the WCLK is simply to identify the beginning of a frame. In particular the frame start at the rising edge of WCLK, and the WCLK widths supported are:

- 50% duty cycle
- One slot width (16 BCLK)
- One BCLK width

In TDM mode, AIS25BA shall output accelerometer data on the SDOUT pin at the following sampling rates:

- WCLK = 8 kHz
- WCLK = 16 kHz
- WCLK = 24 kHz

As depicted in [Figure 4. TDM block diagram](#), the TDM input sampling rate (ODR_8kHz, ODR_16kHz and ODR_24kHz), and the associated data inputs (dataX_8kHz, dataX_16kHz, dataX_24kHz, dataY_8kHz, dataY_16kHz, dataY_24kHz, dataZ_8kHz, dataZ_16kHz and dataZ_24kHz) can be selected in two different ways:

1. Using the I²C register `wclk_fq` ([TDM_CTRL_REG \(2Eh\)](#), bits 2 and 1). In this case the I²C register `ODR_AUTO_EN` ([CTRL_REG_2 \(2Fh\)](#), bit 0) is equal to zero, that means that the `ODR_auto` functionality is disabled.
2. Using the output of the `ODR_auto` block (`ODR_AUTO_EN` ([CTRL_REG_2 \(2Fh\)](#), bit 0) equal to one). This latter simply receives as inputs both the MCLK and the WCLK and it computes the current sampling frequency as a ratio between the MCLK and WCLK.

The possible outputs of the `ODR_auto` block are:

- 00: sampling rate equal to 8 kHz (MCLK/WCLK = 1536)
- 01: sampling rate equal to 16 kHz (MCLK/WCLK = 768)
- 10: sampling rate equal to 24 kHz (MCLK/WCLK = 512)

Observing [Figure 4](#), it is possible to see, that if a ratio between MCLK and WCLK differ from 1536, 768 and 512, the sampling rate equal to 8 kHz is selected.

4.3 Serial clock (BCLK)

The sole purpose of the serial clock BCLK is to shift the data out of the serial SDOUT port. To this purpose, the TDM interface uses an internal counter that is set to one when the rising edge of the WCLK is detected, and it is reset to zero when the maximum number of BCLK in a WCLK period is reached.

The maximum number of BCLK contained in a WCLK period (`cmax` input of the TDM in [Figure 4. TDM block diagram](#)) can be expressed as a function of both the BCLK and WCLK frequencies, and can be computed using the following equation:

$$cmax = \frac{BCLK}{WCLK} - 1$$

In order to support a serial clock BCLK variable in the range [1024 MHz, 12.288 MHz], and consequently to compute the correct maximum value of the internal TDM counter, two possible solutions can be selected:

- The `cmax` value at the input of the TDM interface can be computed on the fly employing the `BCLK_AUTO` block (see [Figure 4](#)), which is able to compute the `cmax` value using the above equation. This functionality by default is enabled, and can be disabled employing the I²C register `ODR_AUTO_EN` ([CTRL_REG_2 \(2Fh\)](#) bit 0).
- The TDM `cmax` can be programmed through the I²C registers [TDM_cmax \(24h-25h\)](#).

4.4 Mapping the TDM axes

Within one frame, the data signal (DOUT) is divided into multiple segments. We call each segment a slot hereafter in this document.

The data slot width is fixed and equal to 16 bits.

In each slot, data should be left-justified (MSB first).

The number of slots in a WCLK frame can be variable, and it depends on the ratio between BCLK and WCLK. However, as depicted in [Table 9](#) and [Table 10](#), only the slots 0, 1, 2 and 4, 5, 6 can be used to send accelerometer data, all the others slots are always set in high-impedance.

The mapping of the input data and the TDM output slots is flexible and can be configured through the I²C register mapping ([TDM_CTRL_REG \(2Eh\)](#) bit 4) in [Figure 4](#).

In particular two possible configurations can be selected:

- Axes data (X,Y,Z) mapped on TDM slots (0,1,2) (mapping = 0)
- Axes data (X,Y,Z) mapped on TDM slots (4,5,6) (mapping = 1)

Table 9. X, Y, Z axes mapped to SLOT0, SLOT1, SLOT2

SLOT0	SLOT1	SLOT2	SLOT3	SLOT4	SLOT5	SLOT6	SLOT7	...	SLOTN
X-axis	Y-axis	Z-axis	HiZ	HiZ	HiZ	HiZ	HiZ	...	HiZ

Table 10. X, Y, Z axes mapped to SLOT4, SLOT5, SLOT6

SLOT0	SLOT1	SLOT2	SLOT3	SLOT4	SLOT5	SLOT6	SLOT7	...	SLOTN
HiZ	HiZ	HiZ	HiZ	X-axis	Y-axis	Z-axis	HiZ	...	HiZ

4.5 TDM configurations

All the AIS25BA TDM configurations programmable over the I²C interface are explained in detail in the following subsections.

4.5.1 Configuration 1

- No delay: SLOT0 data MSB is sampled on the first rising edge of BCLK after rising edge of WCLK (delayed I²C register `TDM_CTRL_REG (2Eh)` bit 6 equal to zero)
- Data valid: data valid on the rising edge of BCLK (data_valid I²C register `TDM_CTRL_REG (2Eh)` bit 5 equal to zero)

Figure 5. WCLK, SDOUT change on the falling edge of BCLK and are valid on the rising edge of BCLK, no delay

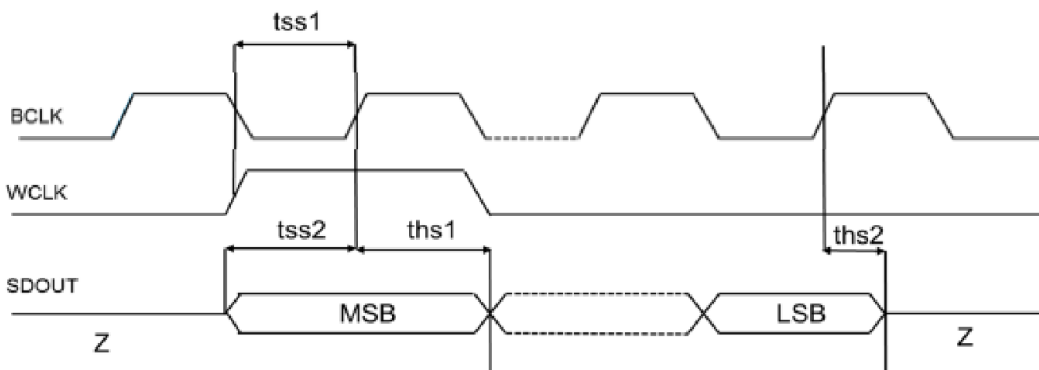

Note: Setup and hold times are defined in [Table 5. TDM interface characteristics](#).

4.5.2 Configuration 2

- No delay: SLOT0 data MSB is sampled on the first falling edge of BCLK after rising edge of WCLK (delayed I²C register `TDM_CTRL_REG (2Eh)` bit 6 equal to zero)
- Data valid: data valid on the falling edge of BCLK (data_valid I²C register `TDM_CTRL_REG (2Eh)` bit 5 equal to one)

Figure 6. WCLK, SDOUT change on the rising edge of BCLK and are valid on the falling edge of BCLK, no delay

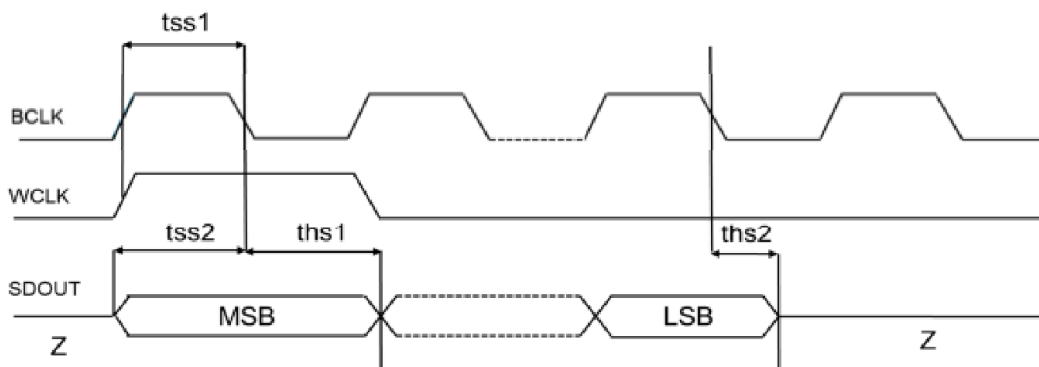

Note: Setup and hold times are defined in [Table 5. TDM interface characteristics](#).

4.5.3 Configuration 3

- Delayed: SLOT0 data MSB is sampled on the second rising edge of BCLK after rising edge of WCLK (delayed I²C register **TDM_CTRL_REG (2Eh)** bit 6 equal to one)
- Data valid: data valid on the rising edge of BCLK (data_valid I²C register **TDM_CTRL_REG (2Eh)** bit 5 equal to zero)

Figure 7. WCLK, SDOUT change on the falling edge of BCLK and are valid on the rising edge of BCLK, delayed

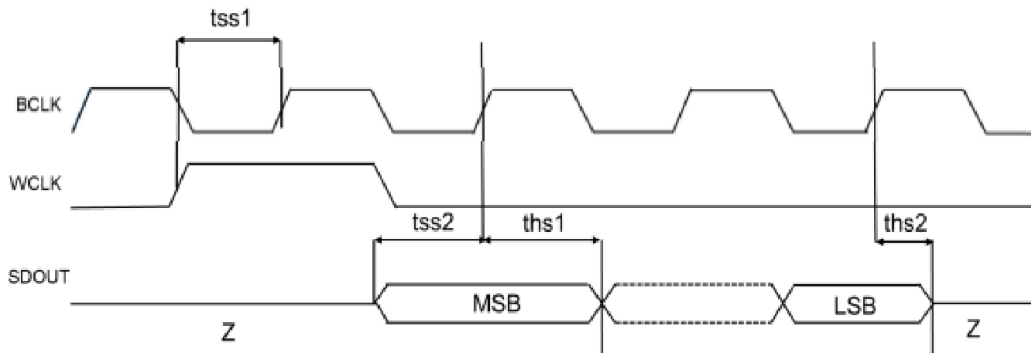

Note: Setup and hold times are defined in [Table 5. TDM interface characteristics](#).

4.5.4 Configuration 4

- Delayed: SLOT0 data MSB is sampled on the second falling edge of BCLK after rising edge of WCLK (delayed I²C register **TDM_CTRL_REG (2Eh)** bit 6 equal to one)
- Data valid: data valid on the falling edge of BCLK (data_valid I²C register **TDM_CTRL_REG (2Eh)** bit 5 equal to one)

Figure 8. WCLK, SDOUT change on the rising edge of BCLK and are valid on the falling edge of BCLK, delayed

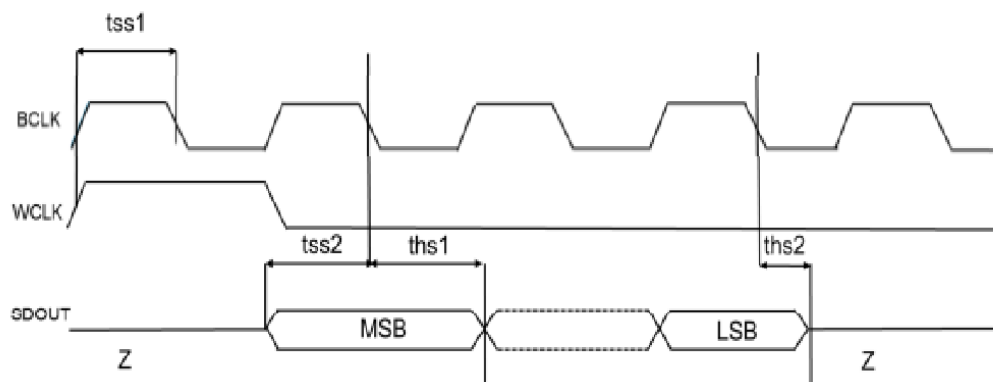

Note: Setup and hold times are defined in [Table 5. TDM interface characteristics](#).

4.6 TDM clocks and MCLK requirements

The relationship between TDM clocks and MCLK should be:

- Both BCLK and WCLK must be obtained from MCLK by integer division. This requirement is mandatory since ADC is clocked by MCLK, so the TDM data rate must be perfectly synchronous in frequency and phase with the decimated ADC data rate.
- The BCLK/WCLK ratio must be an integer value.

5 I²C- inter-IC control interface

5.1 I²C interface

The registers embedded inside the AIS25BA may be accessed also through the I²C serial interfaces.

Table 11. I²C serial interface pin description

Pin name	Pin description
I2C_SCL	I ² C serial clock (SCL)
I2C_SDA	I ² C serial data (SDA)

The AIS25BA I²C is a bus slave. The I²C is employed to write data into registers whose content can also be read back.

The relevant I²C terminology is given in the table below.

Table 12. I²C terminology

Term	Description
Transmitter	The device that sends data to the bus
Receiver	The device that receives data from the bus
Master	The device that initiates a transfer, generates clock signals, and terminates a transfer
Slave	The device addressed by the master

There are two signals associated with the I²C bus: the serial clock line (SCL) and the serial data line (SDA). The latter is a bidirectional line used for sending and receiving the data to/from the interface. Both lines must be connected to V_{dd} through an external pull-up resistor. When the bus is free, both lines are high.

The I²C interface is compliant with fast mode (400 kHz) I²C standards as well as with the normal mode.

5.2 I²C interface details

The transaction on the bus is started through a start signal. A start condition is defined as a high to low transition on the data line while the SCL line is held high (refer to the ST condition in the following paragraph). After this signal has been transmitted by the master, the bus is considered busy. The next byte of data transmitted after the start condition contains the address of the slave in the first 7 bits and the eighth bit tells whether the master is receiving data from the slave or transmitting data to the slave (SAD subsequences). When an address is sent, each device in the system compares the first seven bits after a start condition with its address. If they match, the device considers itself addressed by the master. The address can be made up of a programmable part and a fixed part, thus allowing more than one device of the same type to be connected to the I²C bus.

Data transfer with acknowledge is mandatory. The transmitter must release the SDA line during the acknowledge pulse. The receiver must then pull the data line low so that it remains stable low during the high period of the acknowledge clock pulse (SAK subsequence). A receiver that has been addressed must generate an acknowledge after each byte of data has been received. The I²C embedded inside the AIS25BA behaves like a slave device and the following protocol must be adhered to. After the start condition (ST) a slave address is sent, once a slave acknowledge has been returned (SAK), an 8-bit subaddress is transmitted (SUB): the 7 LSB represent the actual register address while the MSB enables address auto-increment. If the MSB of the SUB field is 1, the SUB (register address) is automatically incremented to allow multiple data read/write at increasing addresses. Otherwise, if the MSB of the SUB field is 0, the SUB remains unchanged and multiple read/write on the same address can be performed. If the LSB of the slave address is 1 (read), a repeated start (SR) condition must be issued after the subaddress byte; if the LSB is 0 (write) the master transmits to the slave with direction unchanged.

5.3 I²C slave address

The slave address is equal to 001100yx (TDM mode, where y = not(I2C_A0 pin)) or in case of writing or reading respectively.

5.4 I²C read and write sequences

Previous subsequences are used for the actual write and read sequences described in the tables below.

Table 13. Transfer when master is writing one byte to slave

Master	ST	SAD + W		SUB		DATA		SP
Slave			SAK		SAK		SAK	

Table 14. Transfer when master is writing multiple bytes to slave

Master	ST	SAD + W		SUB		DATA		DATA		SP
Slave			SAK		SAK		SAK		SAK	

Table 15. Transfer when master is receiving (reading) one byte of data from slave

Master	ST	SAD + W		SUB		SR	SAD + R			NMAK	SP
Slave			SAK		SAK			SAK	DATA		

Table 16. Transfer when master is receiving (reading) multiple bytes of data from slave

Master	ST	SAD+W		SUB		SR	SAD+R		MAK		MAK		NMAK	SP
Slave			SAK		SAK			SAK	DATA		DATA		DATA	

Data are transmitted in byte format (DATA). Each data transfer contains 8 bits. The number of bytes transferred per transfer is unlimited. Data is transferred with the most significant bit (MSB) first. If a slave receiver doesn't acknowledge the slave address (that is, it is not able to receive because it is performing some real-time function) the data line must be left high by the slave. The master can then abort the transfer. A low to high transition on the SDA line while the SCL line is high is defined as a stop condition (SP). Each data transfer must be terminated by the generation of a stop condition.

6 Features

6.1 Self-test mode

In self-test mode the mechanical element is stimulated by electrostatic force to obtain an equivalent input force applied to the sensor. This equivalent input force applied has to be comparable with the full-scale range in order to have an effective self-test mode.

The self-test mode can be enabled using the I²C interface, setting the ST bit in register TEST_REG (0Bh) to 1. For the self-test values of each axis please refer to Table 2. Mechanical characteristics.

6.2 Power cycle/reset information

6.2.1 TDM interface power-on sequence

In TDM, the AIS25BA starts in disabled mode with the following sequence.

Figure 9. Power-on sequence (TDM interface)

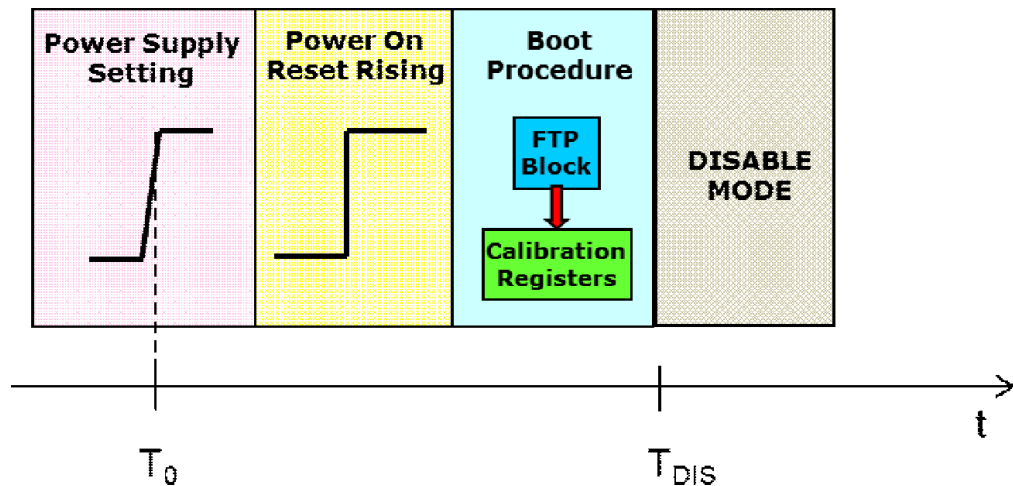

In the figure above, T_0 represents the time when V_{DD} reaches 90% of the final value.

After $T_{DIS} = 5.5$ ms the AIS25BA reaches the disabled mode condition.

The TDM interface must be activated explicitly with I²C configuration. The first 3 samples after the enabling of the TDM may be invalid samples due to the fact that the interface should sync on the external WCLK. The samples will be invalid also after any subsequent disable-enable transition that may happen. TDM protocol can be changed on the fly, but also in this case the first 3 samples after the TDM configuration change will be invalid.

6.2.2 Disabled mode

The AIS25BA can be put in disabled mode using the I²C interface. The power-down command will be executed immediately (no wait state).

The AIS25BA can be resumed from disabled mode using the I²C as well. In this case the MCLK/BCLK/WCLK clocks must be set to the correct values before writing to the I²C.

Please refer to the following figure for the disabled mode sequence.

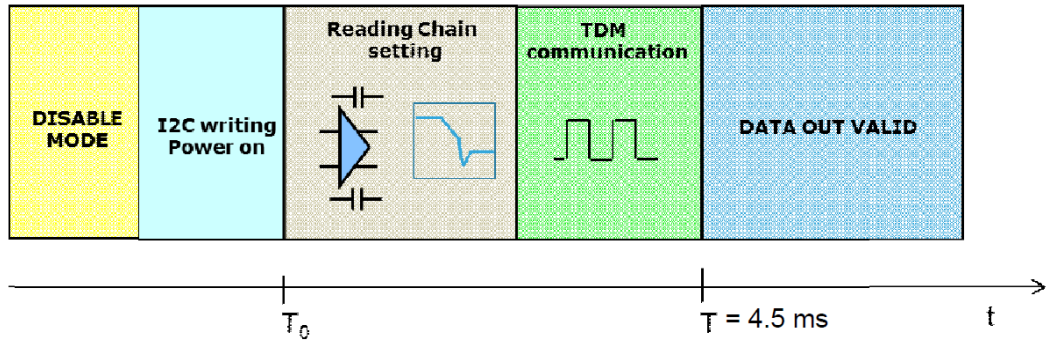
Figure 10. Disabled mode sequence

7 Register map

The table below provides a list of the 8-bit registers embedded in the device and their respective addresses.

Table 17. Registers address map

Name	Type ⁽¹⁾	Register address		Default
		Hex	Binary	
TEST_REG	R/W	0B	0000 1011	0000 0000
WHO_AM_I	R	0F	0000 1111	0010 0000
TDM_cmax[11:8]	R/W	24	0010 0100	0000 0000
TDM_cmax[7:0]	R/W	25	0010 0101	0111 1111
CTRL_REG_1	R/W	26	0010 0110	0010 0000
TDM_CTRL_REG	R/W	2E	0010 1110	1111 0000
CTRL_REG_2	R/W	2F	0010 1111	1110 0001
CTRL_REG_FS	R/W	30	0011 1111	0000 0000

1. Read only (R) - read/write (R/W)

8 Register description

8.1 TEST_REG (0Bh)

Self-test register (R/W)

Table 18. TEST_REG register

0 ⁽¹⁾	0 ⁽¹⁾	0 ⁽¹⁾	0 ⁽¹⁾	ST	0 ⁽¹⁾	0 ⁽¹⁾	0 ⁽¹⁾
------------------	------------------	------------------	------------------	----	------------------	------------------	------------------

1. This bit must be set to 0 for the correct operation of the device.

Table 19. TEST_REG register description

ST	Enables self-test mode. Default value: 0 (0: disabled; 1: enabled)
----	---

8.2 WHO_AM_I (0Fh)

Device identification register (R)

Table 20. WHO_AM_I register

0	0	1	0	0	0	0	0
---	---	---	---	---	---	---	---

8.3 TDM_cmax (24h-25h)

TDM counter max value when the BCLK autoconfiguration feature is disabled (R/W)

Table 21. TDM_cmax register

-	-	-	-	TDM_cmax[11:8] MSB
---	---	---	---	--------------------

TDM_cmax[7:0] LSB

8.4 CTRL_REG_1 (26h)

Control register (R/W)

Table 22. CTRL_REG_1 register

0 ⁽¹⁾	0 ⁽¹⁾	PD	0 ⁽¹⁾	0 ⁽¹⁾	0 ⁽¹⁾	0 ⁽¹⁾	0 ⁽¹⁾
------------------	------------------	----	------------------	------------------	------------------	------------------	------------------

1. This bit must be set to 0 for the correct operation of the device.

Table 23. CTRL_REG_1 register description

PD	Device in disabled mode. Default value: 1 (0: normal mode; 1: disabled mode: minimum power consumption, I ² C still active)
----	---

8.5 TDM_CTRL_REG (2Eh)

(R/W)

Table 24. TDM_CTRL_REG register

TDM_pd	Delayed	data_valid	mapping	0 ⁽¹⁾	WCLK_fq1	WCLK_fq0	0 ⁽¹⁾
--------	---------	------------	---------	------------------	----------	----------	------------------

1. This bit must be set to 0 for the correct operation of the device.

Table 25. TDM_CTRL_REG register description

TDM_pd	Enables TDM. Default value: 1 (0: TDM on; 1: TDM off)
Delayed	TDM delayed configuration. Default value: 1 (0: TDM no delayed configuration; 1: TDM delayed configuration)
data_valid	TDM data valid. Default value: 1 (0: data valid on the rise edge of BCLK; 1: data valid on the falling edge of BCLK)
mapping	TDM mapping. Default value: 1 (0: AXEX → SLOT0; AXEY → SLOT1; AXEZ → SLOT2; 1: AXEX → SLOT4; AXEY → SLOT5; AXEZ → SLOT6)
WCLK_fq [1:0]	TDM clock frequencies. Default value: 00 (00: WCLK = 8 kHz; 01: WCLK = 16 kHz; 10: WCLK = 24 kHz)

8.6 CTRL_REG_2 (2Fh)

(R/W)

Table 26. CTRL_REG_2 register

1 ⁽¹⁾	1 ⁽¹⁾	1 ⁽¹⁾	0 ⁽²⁾	0 ⁽²⁾	0 ⁽²⁾	0 ⁽²⁾	ODR_AUTO_EN
------------------	------------------	------------------	------------------	------------------	------------------	------------------	-------------

1. This bit must be set to 1 for the correct operation of the device.
2. This bit must be set to 0 for the correct operation of the device.

Table 27. CTRL_REG_2 register description

ODR_AUTO_EN	Enables auto ODR. Default value: 1 (0: auto ODR and BCLK disabled ⁽¹⁾ ; 1: auto ODR and BCLK enabled ⁽²⁾)
-------------	---

1. In this case it is mandatory to set *TDM_CTRL_REG (2Eh)* bits 2 and 1 to match the WCLK sampling rate and *TDM_cmax (24h-25h)* to match the BCLK/WCLK ratio
2. AIS25BA automatically measures the ratio $r = MCLK/WCLK$. The WCLK frequency is internally determined as $FW=12.288 \text{ MHz}/r$. FW is used to configure automatically the decimation ratio between the ADC and TDM input data rate (same as TDM output data rate) bypassing *TDM_CTRL_REG (2Eh)* bits 2 and 1 configuration. When ODR_AUTO is 1 also the BCLK/WCLK ratio is automatically computed for proper TDM configuration as described in *TDM_cmax (24h-25h)*.

8.7 CTRL_REG_FS (30h)

Accelerometer full-scale selection (R/W)

Table 28. CTRL_REG_FS register

0 ⁽¹⁾	0 ⁽¹⁾	0 ⁽¹⁾	0 ⁽¹⁾	0 ⁽¹⁾	0 ⁽¹⁾	0 ⁽¹⁾	FS
------------------	------------------	------------------	------------------	------------------	------------------	------------------	----

1. This bit must be set to 0 for the correct operation of the device.

Table 29. CTRL_REG_FS register description

FS	Full-scale range selection. Default value: 0 (0: FS ± 3.85 g; 1: ± 7.7 g)
----	--

9 Soldering information

The LGA package is compliant with the [ECOPACK](#) and RoHS standard.

It is qualified for soldering heat resistance according to JEDEC J-STD-020.

For land pattern and soldering recommendations, consult technical note [TN0018](#) available on www.st.com.

10 Package information

In order to meet environmental requirements, ST offers these devices in different grades of **ECOPACK** packages, depending on their level of environmental compliance. ECOPACK specifications, grade definitions and product status are available at: www.st.com. ECOPACK is an ST trademark.

10.1 LGA-14 package information

The LGA-14 package is classified MSL 3.

Figure 11. LGA-14 2.5 x 2.5 x 0.86 mm package outline and mechanical data

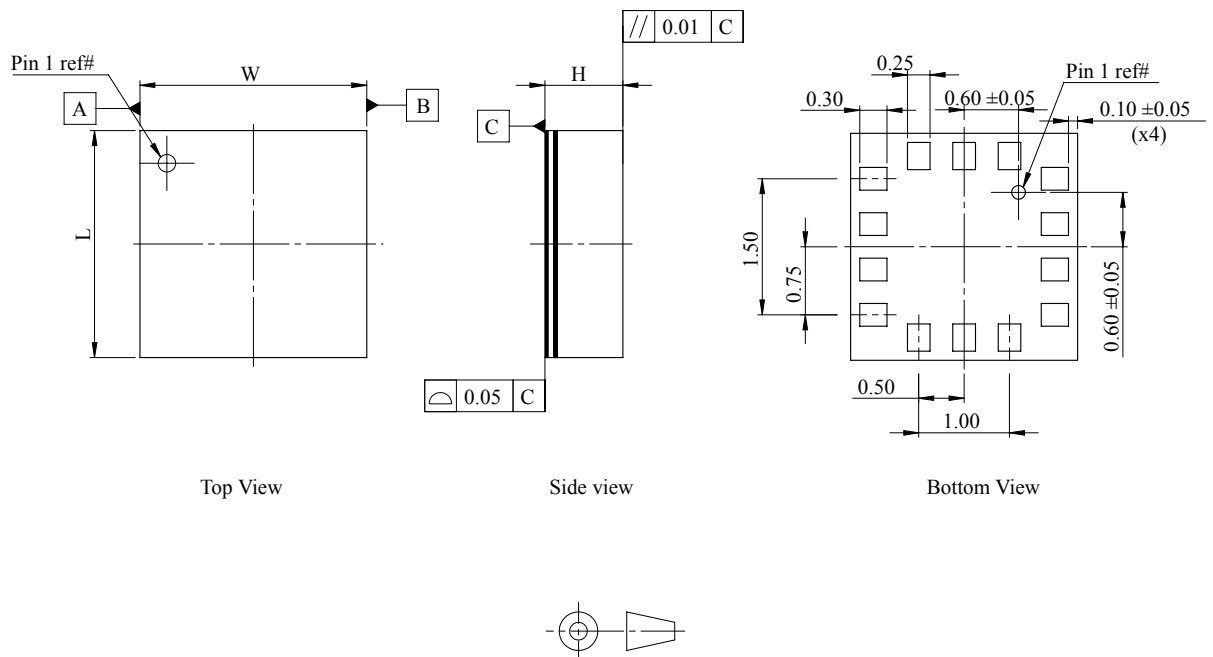

Dimensions are in millimeters unless otherwise specified
General tolerance is ± 0.1 mm unless otherwise specified

OUTER DIMENSIONS

ITEM	DIMENSION (mm)	TOLERANCE (mm)
Length (L)	2.5	± 0.1
Width (W)	2.5	± 0.1
Height (H)	0.86 Max	/

8535512_2

10.2 LGA-14 packing information

Figure 12. Carrier tape information for LGA-14 package

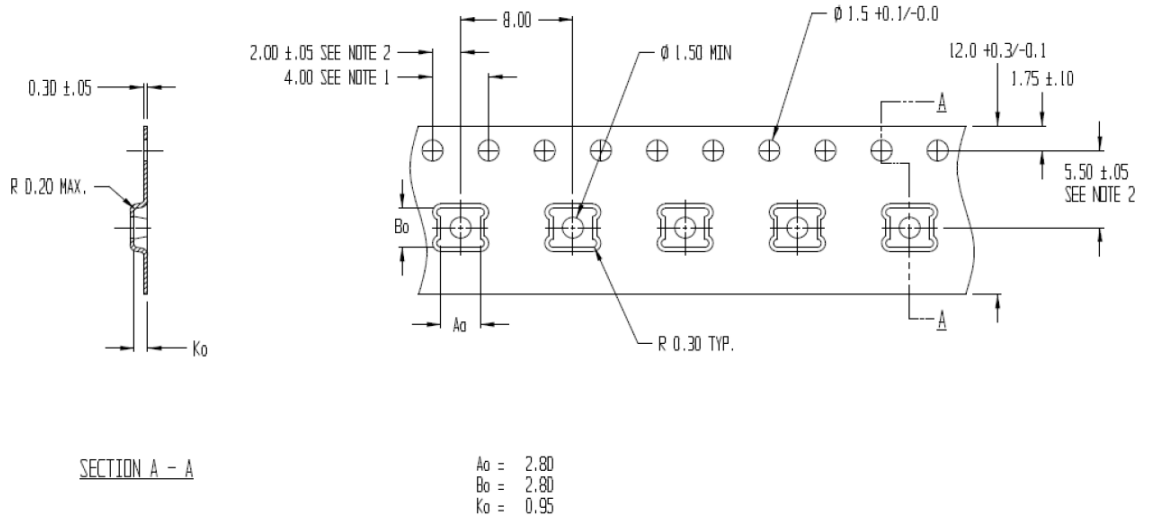

Figure 13. LGA-14 package orientation in carrier tape

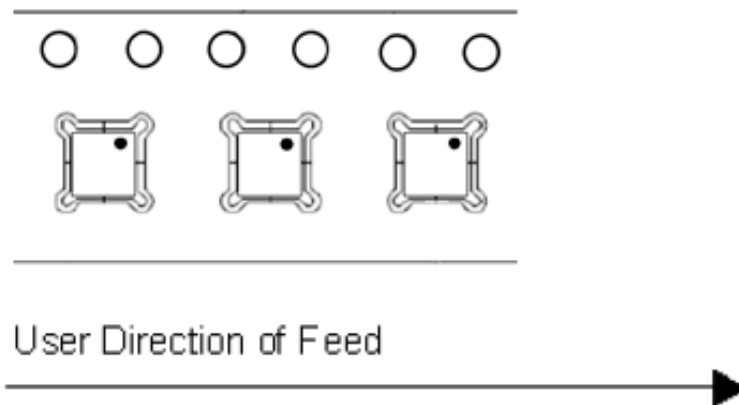

Figure 14. Reel information for carrier tape of LGA-14 package

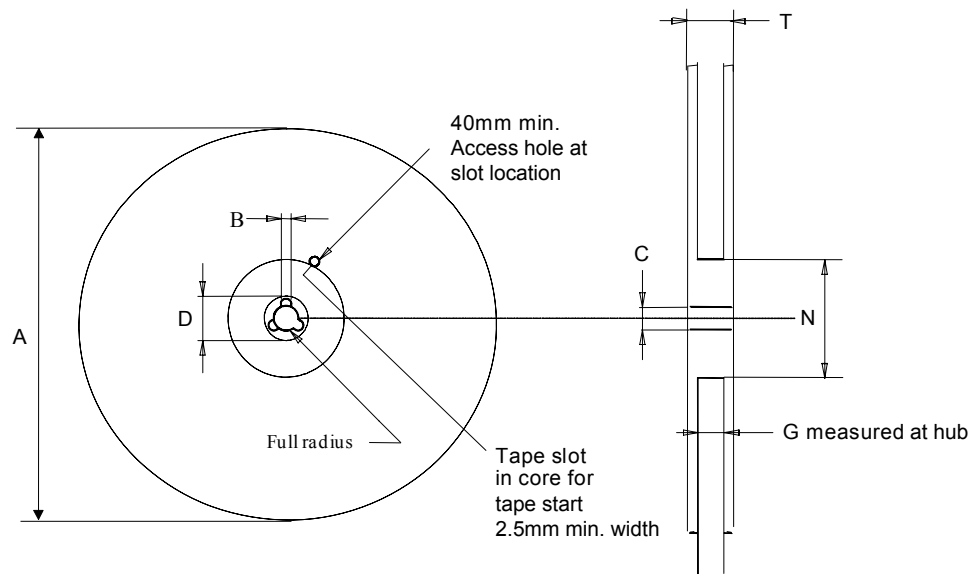

Table 30. Reel dimensions for carrier tape of LGA-14 package

Reel dimensions (mm)	
A (max)	330
B (min)	1.5
C	13 ±0.25
D (min)	20.2
N (min)	60
G	12.4 +2/-0
T (max)	18.4

Revision history

Table 31. Document revision history

Date	Version	Changes
18-Jul-2022	1	Initial release

Contents

1	Pin description	2
2	Mechanical and electrical specifications	3
2.1	Mechanical characteristics	3
2.2	Electrical characteristics	4
2.3	Absolute maximum ratings	5
3	TDM interface characteristics	6
3.1	I ² C interface characteristics	7
4	TDM interface specifications	9
4.1	TDM interface overview	9
4.2	Frame synchronization (WCLK)	10
4.3	Serial clock (BCLK)	10
4.4	Mapping the TDM axes	11
4.5	TDM configurations	12
4.5.1	Configuration 1	12
4.5.2	Configuration 2	12
4.5.3	Configuration 3	13
4.5.4	Configuration 4	13
4.6	TDM clocks and MCLK requirements	13
5	I²C- inter-IC control interface	14
5.1	I ² C interface	14
5.2	I ² C interface details	15
5.3	I ² C slave address	15
5.4	I ² C read and write sequences	15
6	Features	16
6.1	Self-test mode	16
6.2	Power cycle/reset information	16
6.2.1	TDM interface power-on sequence	16
6.2.2	Disabled mode	17
7	Register map	18
8	Register description	19
8.1	TEST_REG (0Bh)	19
8.2	WHO_AM_I (0Fh)	19
8.3	TDM_cmax (24h-25h)	19
8.4	CTRL_REG_1 (26h)	19

8.5	TDM_CTRL_REG (2Eh).....	20
8.6	CTRL_REG_2 (2Fh).....	20
8.7	CTRL_REG_FS (30h).....	21
9	Soldering information.....	22
10	Package information.....	23
10.1	LGA-14 package information.....	23
10.2	LGA-14 packing information.....	24
	Revision history.....	26
	List of tables.....	29
	List of figures.....	30

List of tables

Table 1.	Pin description	2
Table 2.	Mechanical characteristics	3
Table 3.	Electrical characteristics	4
Table 4.	Absolute maximum ratings	5
Table 5.	TDM interface characteristics	6
Table 6.	Digital input/output voltage for I ² C pins	7
Table 7.	I ² C interface characteristics	7
Table 8.	I ² C high-speed mode specifications at 1 MHz	8
Table 9.	X, Y, Z axes mapped to SLOT0, SLOT1, SLOT2	11
Table 10.	X, Y, Z axes mapped to SLOT4, SLOT5, SLOT6	11
Table 11.	I ² C serial interface pin description	14
Table 12.	I ² C terminology	14
Table 13.	Transfer when master is writing one byte to slave	15
Table 14.	Transfer when master is writing multiple bytes to slave	15
Table 15.	Transfer when master is receiving (reading) one byte of data from slave	15
Table 16.	Transfer when master is receiving (reading) multiple bytes of data from slave	15
Table 17.	Registers address map	18
Table 18.	TEST_REG register	19
Table 19.	TEST_REG register description	19
Table 20.	WHO_AM_I register	19
Table 21.	TDM_cmax register	19
Table 22.	CTRL_REG_1 register	19
Table 23.	CTRL_REG_1 register description	19
Table 24.	TDM_CTRL_REG register	20
Table 25.	TDM_CTRL_REG register description	20
Table 26.	CTRL_REG_2 register	20
Table 27.	CTRL_REG_2 register description	20
Table 28.	CTRL_REG_FS register	21
Table 29.	CTRL_REG_FS register description	21
Table 30.	Reel dimensions for carrier tape of LGA-14 package	25
Table 31.	Document revision history	26

List of figures

Figure 1.	Pin connections	2
Figure 2.	TDM interface characteristics	6
Figure 3.	I ² C slave timing diagram	8
Figure 4.	TDM block diagram	9
Figure 5.	WCLK, SDOUT change on the falling edge of BCLK and are valid on the rising edge of BCLK, no delay	12
Figure 6.	WCLK, SDOUT change on the rising edge of BCLK and are valid on the falling edge of BCLK, no delay	12
Figure 7.	WCLK, SDOUT change on the falling edge of BCLK and are valid on the rising edge of BCLK, delayed.	13
Figure 8.	WCLK, SDOUT change on the rising edge of BCLK and are valid on the falling edge of BCLK, delayed.	13
Figure 9.	Power-on sequence (TDM interface)	16
Figure 10.	Disabled mode sequence	17
Figure 11.	LGA-14 2.5 x 2.5 x 0.86 mm package outline and mechanical data	23
Figure 12.	Carrier tape information for LGA-14 package	24
Figure 13.	LGA-14 package orientation in carrier tape.	24
Figure 14.	Reel information for carrier tape of LGA-14 package	25

IMPORTANT NOTICE – READ CAREFULLY

STMicroelectronics NV and its subsidiaries (“ST”) reserve the right to make changes, corrections, enhancements, modifications, and improvements to ST products and/or to this document at any time without notice. Purchasers should obtain the latest relevant information on ST products before placing orders. ST products are sold pursuant to ST’s terms and conditions of sale in place at the time of order acknowledgment.

Purchasers are solely responsible for the choice, selection, and use of ST products and ST assumes no liability for application assistance or the design of purchasers’ products.

No license, express or implied, to any intellectual property right is granted by ST herein.

Resale of ST products with provisions different from the information set forth herein shall void any warranty granted by ST for such product.

ST and the ST logo are trademarks of ST. For additional information about ST trademarks, refer to www.st.com/trademarks. All other product or service names are the property of their respective owners.

Information in this document supersedes and replaces information previously supplied in any prior versions of this document.

© 2022 STMicroelectronics – All rights reserved