

# CC06FA

## Automotive grade fast-acting chip fuse



### Product features

- AEC-Q200 qualified
- 0603 (1608 metric) compact design utilizes less board space
- Rapid interruption of excessive current
- Compatible with reflow and wave solder
- Rugged ceramic and glass construction
- Excellent environmental integrity
- One time positive disconnect
- High breaking capacity up to 63 V
- Moisture sensitivity level (MSL) :1

### Applications

Automotive

- Battery management systems (BMS)
- Central body control module
- Doors, window lift and seat control
- Digital instrument cluster
- In-vehicle infotainment (IVI) and navigation
- Electric pumps, motor control and auxiliaries
- Powertrain control module (PCU)/engine control unit (ECU)
- Transmission control unit (TCU)

### Agency information

- UL Recognized File: File E19180
- AEC-Q200 qualified

### Ordering

- Use ordering codes (see page 3 for details)

### Packaging suffixes

- -TR (5,000 parts in paper tape on a 178 mm (7") reel)

### Electrical characteristics

Amp Rating	% of Amp Rating	Opening Time
500 mA – 1.5 A	100%	4 hours minimum
500 mA – 1.5 A	200%	60 seconds maximum

### Product specifications

Part Number <sup>5</sup>	Current rating (A)	Voltage rating (Vdc)	Interrupting rating <sup>1</sup> (A)	Typical DC cold resistance <sup>2</sup> ( $\Omega$ )	Typical pre-arcing <sup>3</sup> I <sup>2</sup> t (A <sup>2</sup> s)	Typical voltage drop (V)	Part marking
CC06FA500mA	0.5	63	50	1.025	0.0019	0.60	F
CC06FA750mA	0.75	63	50	0.510	0.003	0.50	G
CC06FA1A	1	63	50	0.150	0.007	0.211	H
CC06FA1.25A	1.25	63	50	0.132	0.008	0.201	J
CC06FA1.5A	1.5	63	50	0.086	0.0319	0.138	K

- DC interrupting rating measured at rated voltage, time constant less than 50 microseconds, battery source
- DC cold resistance measured at <10% of rated current
- Typical pre-arcing I<sup>2</sup>t measured with a battery bank at rated dc voltage, 10x-rated current, not to exceed IR, time constant of calibrated circuit less than 50 microsecond
- Typical voltage drop measured at rated current after temperature stabilizes
- Part Number Definition: CC06FAxxx-R  
CC06FA = Product code and size  
xxx - Ampere rating (mA or A)

### Dimensions—mm in

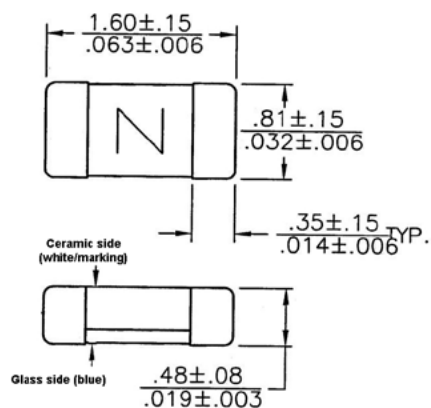

### Recommended pad layout

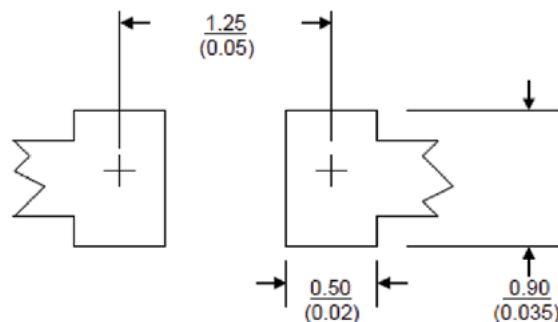

Fuse to be installed with ceramic side up (white/markings)

**Temperature derating curve**

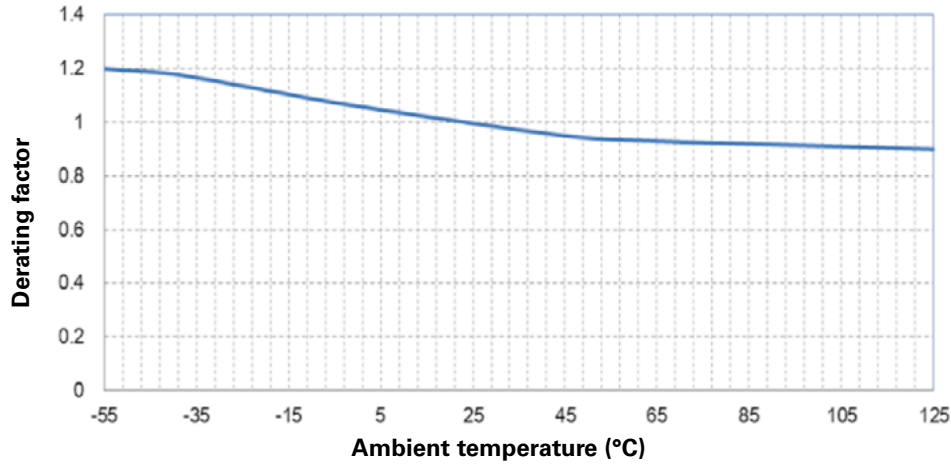

**Environmental data**

---

Operating temperature: -55 °C to +125 °C (with derating)

---

Storage temperature (component): -55 °C to +125 °C

---

Life test: MIL-STD-202, Method 108A, except circulating air environment at +125 °C ±2 °C, apply 60% rated current for 1000 hours

---

Load humidity test: MIL-STD-202, Method 103B except: environmental chamber 85%+2% relative humidity at +85 °C ±2 °C, 10% of rated dc current, at any voltage less than or equal to rated voltage for 1000 hours

---

Terminal strength test: Force of 1.8 kg for 60 seconds

---

TBoard flex test: Downward force is applied to cause a 2 mm deflection for 1 minute (no physical evidence of mechanical or physical damage, change in resistance < 5%)

---

Thermal shock test: MIL-STD-202, Method 107D, -55 °C to +125 °C, 200 cycles

---

Mechanical shock test: MIL-STD-202, Method 213 condition C, 100 g's half-sine for 6 seconds

---

High frequency vibration test: MIL-STD-202, Method 204, 5 g's for 20 minutes, 12 cycles each of 3 orientations, 10 to 2000 Hz

---

Resistance to solvents test: MIL-STD-202, Method 215A

---

High temperature exposure: 1000 hours at +125 °C unpowered

---

Resistance to solder heat: MIL-STD-202 Method 210 condition B

---

Solderability: ANSI/J-STD-002,  
Dip and look test: Test B  
Wetting balance test: Test F  
Resistance to dissolution of metalization test: Test D

---

**Ordering codes**

The ordering code is the part number replacing the “:” with a “-” plus adding the packaging suffix.

**Packaging suffix**

-TR (5,000 parts in paper tape on a 178 mm (7”) reel)

Part Number	Ordering code
	-TR option
CC06FA500mA	CC06FA500mA-TR
CC06FA750mA	CC06FA750mA-TR
CC06FA1A	CC06FA1A-TR
CC06FA1.25A	CC06FA1-25A-TR
CC06FA1.5A	CC06FA1-5A-TR

**Wave solder profile**

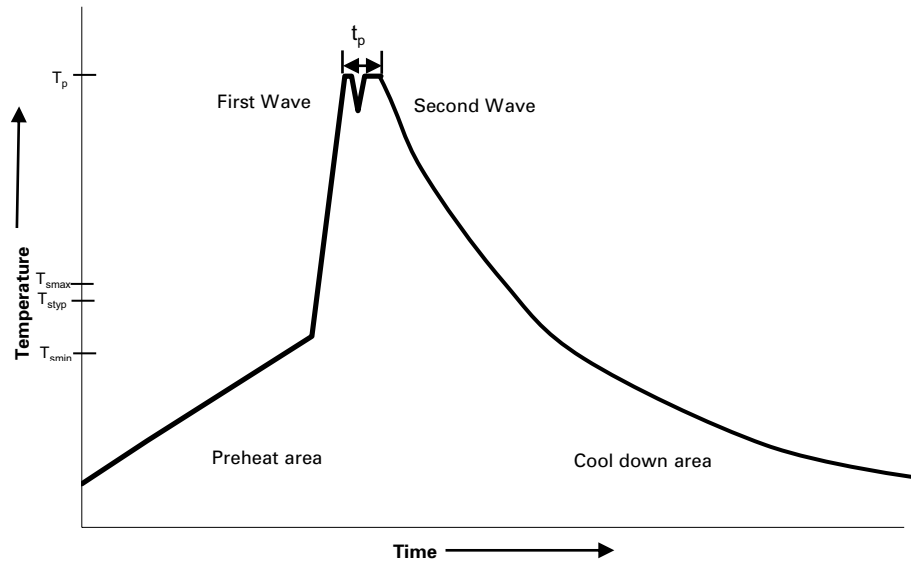

**Reference EN 61760-1:2006**

Profile feature	Standard SnPb solder	Lead (Pb) free solder
Preheat		
• Temperature min. ( $T_{smin}$ )	100 °C	100 °C
• Temperature typ. ( $T_{styp}$ )	120 °C	120 °C
• Temperature max. ( $T_{smax}$ )	130 °C	130 °C
• Time ( $T_{smin}$ to $T_{smax}$ ) ( $t_s$ )	70 seconds	70 seconds
$\Delta$ preheat to max Temperature	150 °C max.	150 °C max.
Peak temperature ( $T_p$ )*	235 °C – 260 °C	250 °C – 260 °C
Time at peak temperature ( $t_p$ )	10 seconds max 5 seconds max each wave	10 seconds max 5 seconds max each wave
Ramp-down rate	~ 2 K/s min ~3.5 K/s typ ~5 K/s max	~ 2 K/s min ~3.5 K/s typ ~5 K/s max
Time 25°C to 25°C	4 minutes	4 minutes

**Manual solder**

+350 °C (4-5 seconds by soldering iron), generally manual/hand soldering is not recommended

**Solder reflow profile**

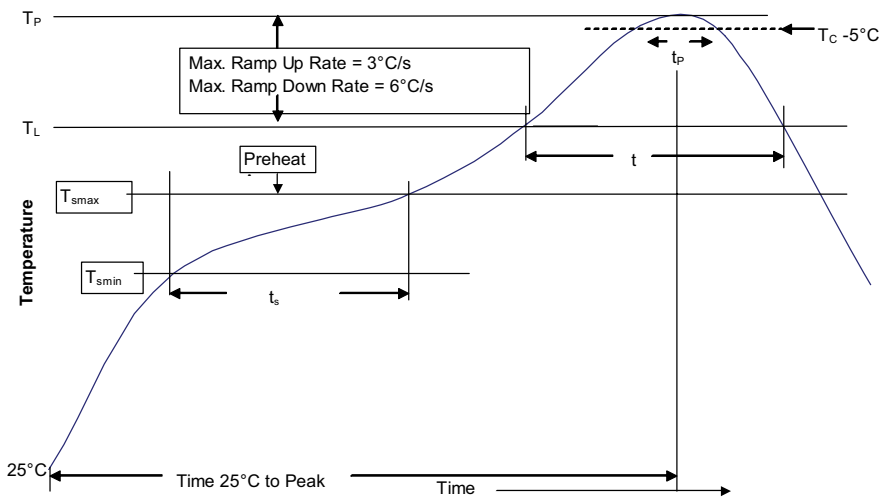

**Table 1 - Standard SnPb solder ( $T_C$ )**

Package thickness	Volume mm <sup>3</sup> <350	Volume mm <sup>3</sup> ≥350
<2.5 mm	235 °C	220 °C
≥2.5 mm	220 °C	220 °C

**Table 2 - Lead (Pb) free solder ( $T_C$ )**

Package thickness	Volume mm <sup>3</sup> <350	Volume mm <sup>3</sup> 350 - 2000	Volume mm <sup>3</sup> >2000
<1.6 mm	260 °C	260 °C	260 °C
1.6 – 2.5 mm	260 °C	250 °C	245 °C
>2.5 mm	250 °C	245 °C	245 °C

**Reference J-STD-020**

Profile feature	Standard SnPb solder	Lead (Pb) free solder
Preheat and soak		
• Temperature min. ( $T_{smin}$ )	100 °C	150 °C
• Temperature max. ( $T_{smax}$ )	150 °C	200 °C
• Time ( $T_{smin}$ to $T_{smax}$ ) ( $t_s$ )	60-120 seconds	60-120 seconds
Ramp up rate $T_L$ to $T_p$	3 °C/ second max.	3 °C/ second max.
Liquidous temperature ( $T_L$ )	183 °C	217 °C
Time ( $t_L$ ) maintained above $T_L$	60-150 seconds	60-150 seconds
Peak package body temperature ( $T_p$ )*	Table 1	Table 2
Time ( $t_p$ )* within 5 °C of the specified classification temperature ( $T_C$ )	20 seconds*	30 seconds*
Ramp-down rate ( $T_p$ to $T_L$ )	6 °C/ second max.	6 °C/ second max.
Time 25 °C to peak temperature	6 minutes max.	8 minutes max.

\* Tolerance for peak profile temperature ( $T_p$ ) is defined as a supplier minimum and a user maximum.

Life Support Policy: Eaton does not authorize the use of any of its products for use in life support devices or systems without the express written approval of an officer of the Company. Life support systems are devices which support or sustain life, and whose failure to perform, when properly used in accordance with instructions for use provided in the labeling, can be reasonably expected to result in significant injury to the user.

Eaton reserves the right, without notice, to change design or construction of any products and to discontinue or limit distribution of any products. Eaton also reserves the right to change or update, without notice, any technical information contained in this bulletin.

**Eaton**  
Electronics Division  
1000 Eaton Boulevard  
Cleveland, OH 44122  
United States  
Eaton.com/electronics

© 2019 Eaton  
All Rights Reserved  
Printed in USA  
Publication No. 11003 BU-MC19130  
November 2019

Eaton is a registered trademark.  
All other trademarks are property of their respective owners.

Follow us on social media to get the latest product and support information.

