

PM2 SERIES

Related Information	■ General terms and conditions..... F-3	■ Selection guide P.393~
	■ Glossary of terms..... P.1549~	■ General precautions P.1552~

- FIBER SENSORS
- LASER SENSORS
- PHOTOELECTRIC SENSORS
- MICRO PHOTOELECTRIC SENSORS
- AREA SENSORS
- SAFETY LIGHT CURTAINS / SAFETY COMPONENTS
- PRESSURE / FLOW SENSORS
- INDUCTIVE PROXIMITY SENSORS
- PARTICULAR USE SENSORS
- SENSOR OPTIONS
- SIMPLE WIRE-SAVING UNITS
- WIRE-SAVING SYSTEMS
- MEASUREMENT SENSORS
- STATIC CONTROL DEVICES
- LASER MARKERS
- PLC
- HUMAN MACHINE INTERFACES
- ENERGY MANAGEMENT SOLUTIONS
- FA COMPONENTS
- MACHINE VISION SYSTEMS
- UV CURING SYSTEMS

- Selection Guide
- U-shaped
- Convergent Reflective

PM2

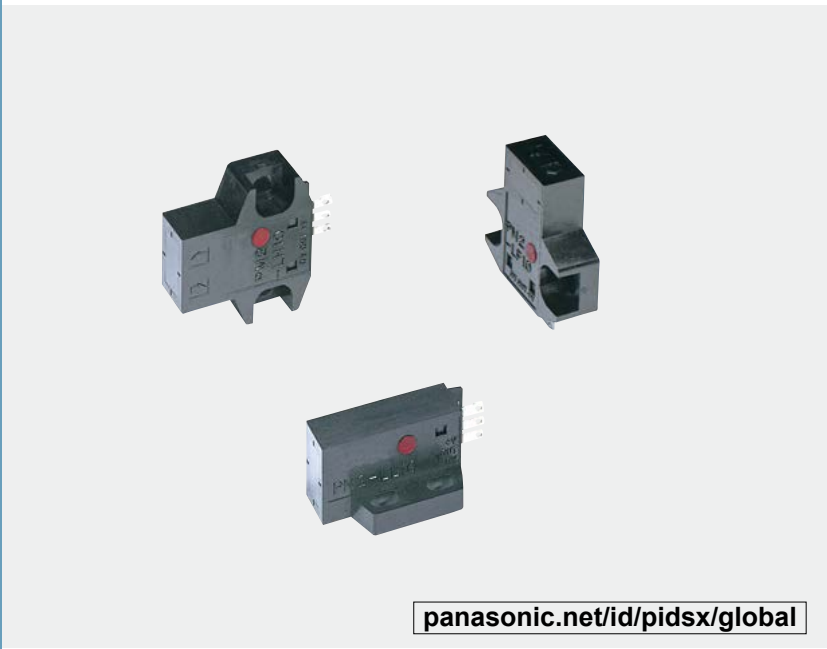

panasonic.net/id/pidsx/global



Convergent reflection sensing ensures stable detection

Stable detection by convergent reflective mode

Stable detection characteristics are obtained since it is convergent reflective type and senses a limited area.

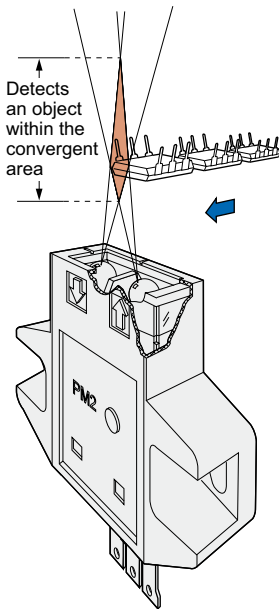

Hardly affected by background

Even a specular background does not affect the sensing performance if the sensor is located 30 mm 1.181 in away from it.

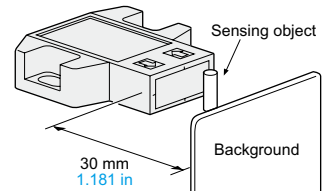

(However, the specular background should be a plane surface, directly facing the sensor. A spherical or curved background may be detected.)

Dark object detectable

Since the sensor is very sensitive, it can detect even a dark object of low reflectivity.

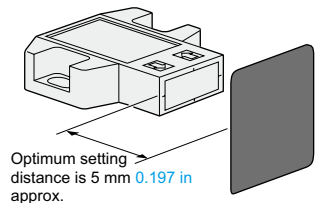

Minute object detectable

A $\varnothing 0.05$ mm $\varnothing 0.002$ in copper wire can be detected at a distance of 5 mm 0.197 in under the optimum condition.

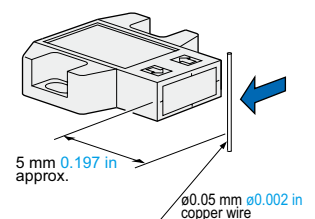

Cable type is also available

Cumbersome soldering is not required. It saves space and improves reliability.

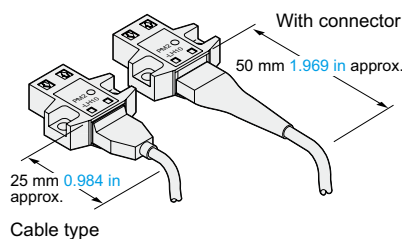

APPLICATIONS

Sensing capacitors in a tray

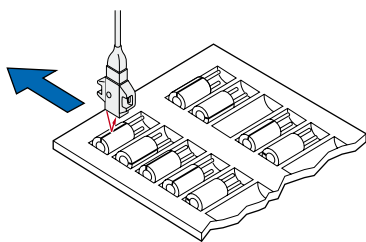

Positioning and passage confirmation of a printed circuit board

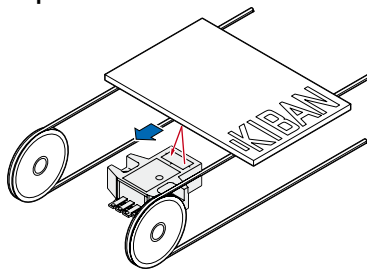

ORDER GUIDE

Type	Appearance	Sensing range	Model No.	Output	Output operation
Connector type	Top sensing 	<div style="display: flex; align-items: center;"> <div style="width: 15px; height: 15px; background-color: #ccc; margin-right: 5px;"></div> <div> 2.5 to 8 mm 0.098 to 0.315 in (Convergent point: 5 mm 0.197 in) </div> </div>	PM2-LH10	NPN open-collector transistor	Light-ON
			PM2-LH10B		Dark-ON
	Front sensing 		PM2-LF10		Light-ON
	PM2-LF10B		Dark-ON		
L type (Top sensing) 	PM2-LL10		Light-ON		
	PM2-LL10B		Dark-ON		
Cable type	Top sensing 		PM2-LH10-C1		Light-ON
			PM2-LH10B-C1		Dark-ON
	Front sensing 		PM2-LF10-C1		Light-ON
			PM2-LF10B-C1		Dark-ON
	L type (Top sensing) 		PM2-LL10-C1		Light-ON
			PM2-LL10B-C1		Dark-ON

FIBER SENSORS

LASER SENSORS

PHOTO-ELECTRIC SENSORS

MICRO PHOTO-ELECTRIC SENSORS

AREA SENSORS

SAFETY LIGHT CURTAINS / SAFETY COMPONENTS

PRESSURE / FLOW SENSORS

INDUCTIVE PROXIMITY SENSORS

PARTICULAR USE SENSORS

SENSOR OPTIONS

SIMPLE WIRE-SAVING UNITS

WIRE-SAVING SYSTEMS

MEASUREMENT SENSORS

STATIC CONTROL DEVICES

LASER MARKERS

PLC

HUMAN MACHINE INTERFACES

ENERGY MANAGEMENT SOLUTIONS

FA COMPONENTS

MACHINE VISION SYSTEMS

UV CURING SYSTEMS

Selection Guide

U-shaped

Convergent Reflective

PM2

OPTIONS

Designation	Model No.	Description
Connector	CN-13	Dedicated connector
Connector attached cable	CN-13-C1	0.2 mm ² 3-core cabtyre cable, 1 m 3.281 ft long
	CN-13-C3	0.2 mm ² 3-core cabtyre cable, 3 m 9.843 ft long

Connector

- **CN-13**

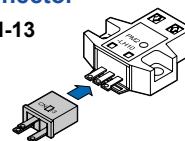

Connector attached cable

- **CN-13-C1**
- **CN-13-C3**

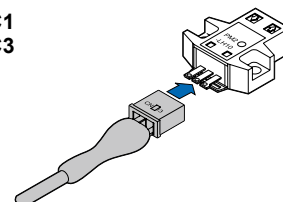

SPECIFICATIONS

Item	Model No.	Type	Connector type			Cable type		
			Top sensing	Front sensing	L type (Top sensing)	Top sensing	Front sensing	L type (Top sensing)
			Light-ON	PM2-LH10	PM2-LF10	PM2-LL10	PM2-LH10-C1	PM2-LF10-C1
		Dark-ON	PM2-LH10B	PM2-LF10B	PM2-LL10B	PM2-LH10B-C1	PM2-LF10B-C1	PM2-LL10B-C1
CE marking directive compliance			EMC Directive, RoHS Directive					
Sensing range			2.5 to 8 mm 0.098 to 0.315 in (Conv. point: 5 mm 0.197 in) with white non-glossy paper (15 × 15 mm 0.591 × 0.591 in) (Note 2)					
Min. sensing object			ø0.05 mm ø0.002 in copper wire (Setting distance: 5 mm 0.197 in)					
Hysteresis			20 % or less of operation distance with white non-glossy paper (15 × 15 mm 0.591 × 0.591 in)					
Repeatability (perpendicular to sensing axis)			0.08 mm 0.003 in or less (Note 3)					
Supply voltage			5 to 24 V DC ±10 % Ripple P-P 5 % or less					
Current consumption			Average: 25 mA or less, Peak: 80 mA or less					
Output			NPN open-collector transistor <ul style="list-style-type: none"> • Maximum sink current: 100 mA • Applied voltage: 30 V DC or less (between output and 0 V) • Residual voltage: 1 V or less (at 100 mA sink current) 0.4 V or less (at 16 mA sink current) 					
Utilization category			DC-12 or DC-13					
Overcurrent protection			Incorporated					
Response time			0.8 ms or less					
Operation indicator			Red LED (lights up when the output is ON)					
Environmental resistance	Pollution degree			3 (Industrial environment)				
	Ambient temperature			-10 to +55 °C +14 to +131 °F (No dew condensation or icing allowed), Storage: -25 to +80 °C -13 to +176 °F				
	Ambient humidity			45 to 85 % RH, Storage: 45 to 85 % RH				
	Ambient illuminance			Incandescent light: 3,500 lx or less at the light-receiving face				
	Vibration resistance			10 to 55 Hz frequency, 1.5 mm 0.059 in double amplitude in X, Y and Z directions for two hours each				
	Shock resistance			500 m/s ² acceleration (50 G approx.) in X, Y and Z directions three times each				
Emitting element			Infrared LED (Peak emission wavelength: 880 nm 0.035 mil , modulated)					
Material			Enclosure: Polycarbonate, Terminal part: Copper alloy (Ag plated)			Enclosure: Polycarbonate, Fixed cable part: PBT		
Cable			—————			0.2 mm ² 3-core cabtyre cable, 1 m 3.281 ft long (Note 4)		
Wiring length			Total length up to 2 m 6.562 ft is possible with 0.3 mm ² , or more, cable. (If the cable is extended for 2 m 6.562 ft , or more, a capacitor of 10 µF must be connected between +V and 0 V terminals.)			—————		
Weight			Net weight: 4.5 g approx. Gross weight: 85 g approx. (10 pcs. package)		Net weight: 4 g approx. Gross weight: 80 g approx. (10 pcs. package)		Net weight: 25 g approx Gross weight: 330 g approx (10 pcs. package)	

- Notes: 1) Where measurement conditions have not been specified precisely, the conditions used were an ambient temperature of +23 °C **+73.4 °F**.
 2) The sensing range may extend up to 12.5 mm **0.492 in** with white non-glossy paper due to product variation.
 3) The repeatability is specified for white non-glossy paper (15 × 15 mm **0.591 × 0.591 in**) at a setting distance of 5 mm **0.197 in**.
 4) Cable cannot be extended.

I/O CIRCUIT AND WIRING DIAGRAMS

I/O circuit diagram

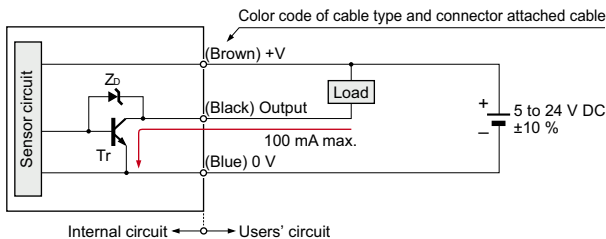

Note: Make sure to connect terminals correctly as the sensor does not incorporate a reverse polarity protection circuit.

Wiring diagram

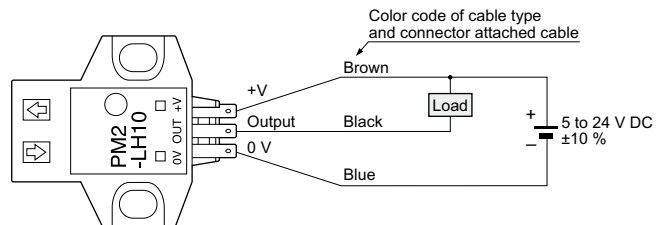

Note: Make sure to connect terminals correctly as the sensor does not incorporate a reverse polarity protection circuit.

Symbols ... Zd: Surge absorption zener diode
Tr: NPN output transistor

FIBER SENSORS
LASER SENSORS
PHOTO-ELECTRIC SENSORS
MICRO PHOTO-ELECTRIC SENSORS
AREA SENSORS
SAFETY LIGHT CURTAINS / SAFETY COMPONENTS
PRESSURE / FLOW SENSORS
INDUCTIVE PROXIMITY SENSORS
PARTICULAR USE SENSORS
SENSOR OPTIONS
SIMPLE WIRE-SAVING UNITS
WIRE-SAVING SYSTEMS
MEASUREMENT SENSORS
STATIC CONTROL DEVICES
LASER MARKERS
PLC
HUMAN MACHINE INTERFACES
ENERGY MANAGEMENT SOLUTIONS
FA COMPONENTS
MACHINE VISION SYSTEMS
UV CURING SYSTEMS

Selection Guide
U-shaped
Convergent Reflective

PM2

SENSING CHARACTERISTICS (TYPICAL)

Sensing fields

- Horizontal (left and right) direction

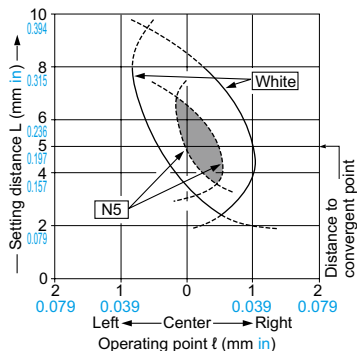

The sensors can be mounted side by side. However, if the sensor is slanted, there may be interference. Verify first whether there is any interference prior to use.

Horizontal direction

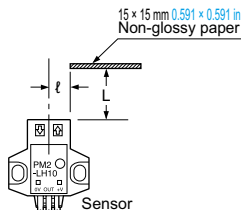

- Vertical (up and down) direction

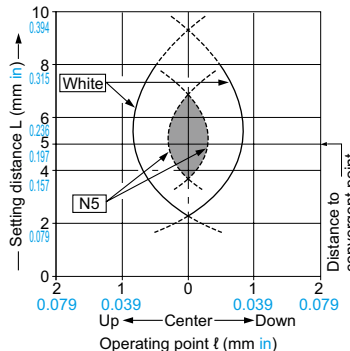

The sensors can be mounted side by side. However, if the sensor is slanted, there may be interference. Verify first whether there is any interference prior to use.

Vertical direction

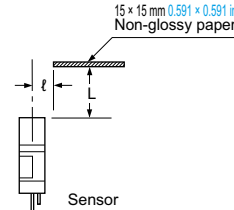

Correlation between lightness and sensing range

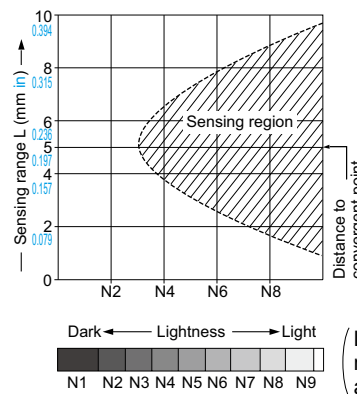

The sensing region (typical) is represented by oblique lines in the left figure. However, the sensitivity should be set with enough margin because of slight variation in products.

(Lightness shown on the left may differ slightly from the actual object condition.)

Correlation between material (15 x 15 mm 0.591 x 0.591 in) and sensing range

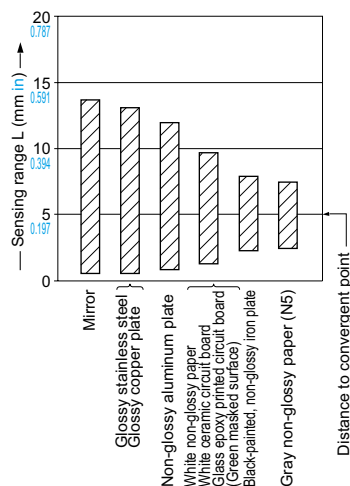

The bars in the graph indicate the sensing range (typical) for the respective material. However, there is a slight variation in the sensing range depending on the product. Further, if there is a reflective object (conveyor, etc.) in the background of the sensing object, since it affects the sensing, separate it by more than twice the sensing range shown in the left graph.

PRECAUTIONS FOR PROPER USE

Refer to p.1552~ for general precautions.

All models



- Never use this product as a sensing device for personnel protection.
- In case of using sensing devices for personnel protection, use products which meet laws and standards, such as OSHA, ANSI or IEC etc., for personnel protection applicable in each region or country.

Mounting

- When fixing the sensor with screws, use M3 screws and the tightening torque should be 0.49 N·m or less. Further, use small, round type plain washers (ø6 mm ø0.236 in).

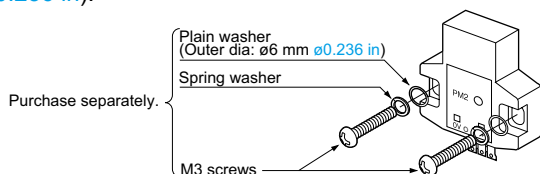

Others

- Do not use during the initial transient time (50 ms) after the power supply is switched on.
- Take care that the product does not come in direct contact with oil, grease, or organic solvents, such as, thinner, etc.

Wiring

- Make sure to connect terminals correctly as the sensor does not incorporate a reverse polarity protection circuit.
- If the sensor is being used in a noisy environment, examine the extent of noise. Further, if equipment, such as motor, solenoid or electromagnetic valve, which generates a large surge, is present near the sensor, connect a surge absorber to the equipment.

Setting

- The optimum setting distance (distance to convergent point) is 5 mm 0.197 in. The sensor is not affected even by a specular background if it is located 30 mm 1.181 in, or more, away from the sensor.

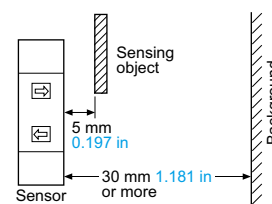

(However, the specular background should be a plane surface, directly facing the sensor. A spherical or curved background may be detected.)

FIBER SENSORS

LASER SENSORS

PHOTO-ELECTRIC SENSORS

MICRO PHOTO-ELECTRIC SENSORS

AREA SENSORS

SAFETY LIGHT CURTAINS / SAFETY COMPONENTS

PRESSURE / FLOW SENSORS

INDUCTIVE PROXIMITY SENSORS

PARTICULAR USE SENSORS

SENSOR OPTIONS

SIMPLE WIRE-SAVING UNITS

WIRE-SAVING SYSTEMS

MEASUREMENT SENSORS

STATIC CONTROL DEVICES

LASER MARKERS

PLC

HUMAN MACHINE INTERFACES

ENERGY MANAGEMENT SOLUTIONS

FA COMPONENTS

MACHINE VISION SYSTEMS

UV CURING SYSTEMS

Selection Guide

U-shaped

Convergent Reflective

PM2

FIBER SENSORS
LASER SENSORS
PHOTO-ELECTRIC SENSORS
MICRO PHOTO-ELECTRIC SENSORS
AREA SENSORS
SAFETY LIGHT CURTAINS / SAFETY COMPONENTS
PRESSURE / FLOW SENSORS
INDUCTIVE PROXIMITY SENSORS
PARTICULAR USE SENSORS
SENSOR OPTIONS
SIMPLE WIRE-SAVING UNITS
WIRE-SAVING SYSTEMS
MEASURE-MENT SENSORS
STATIC CONTROL DEVICES
LASER MARKERS
PLC
HUMAN MACHINE INTERFACES
ENERGY MANAGEMENT SOLUTIONS
FA COMPONENTS
MACHINE VISION SYSTEMS
UV CURING SYSTEMS

PRECAUTIONS FOR PROPER USE

Refer to p.1552~ for general precautions.

Connector type

Cautions in plugging or unplugging a connector



- Do not plug or unplug a connector more than 10 times.
- Be sure not to give stress more than 5 N to a terminal of both a connector and a sensor. If you do not follow the above cautions, it will cause a poor contact.

Procedures of plugging or unplugging a connector

① Insert a connector straight into a sensor until the connector lug is locked by the sensor hook.

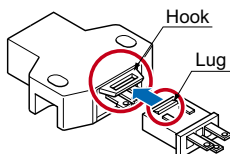

② When unplugging, give as much stress as a connector lug can be relieved from a hook. Then unplug it.

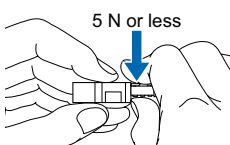

Caution: Be sure to hold a connector when plugging or unplugging it. Do not hold a terminal or a cable when plugging or unplugging the connector. Otherwise, it will cause a poor contact.

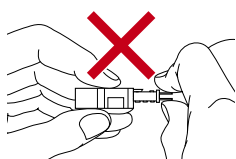

Soldering (Both connector CN-13 and sensor)

- If soldering is done directly on the terminals, strictly adhere to the conditions given below.

Soldering temperature	260 °C 500 °F or less
Soldering time	10 sec. or less
Soldering position	Refer to the below figure

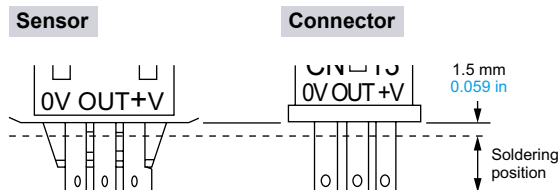

Wiring

- The cable length must be 2 m 6.562 ft, or less, with 0.3 mm², or more, cable. If the cable is extended for more than 2 m 6.562 ft, connect a capacitor of 10 μF approx. between +V and 0 V terminals.

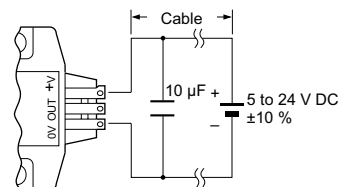

DIMENSIONS (Unit: mm in)

The CAD data can be downloaded from our website.

PM2-LH10 PM2-LH10B Sensor

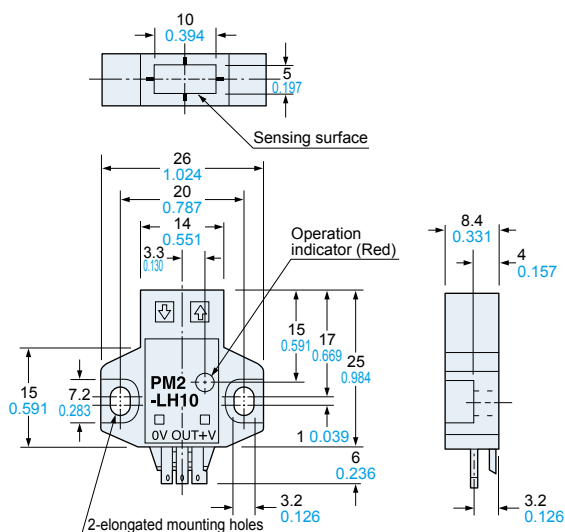

PM2-LF10 PM2-LF10B Sensor

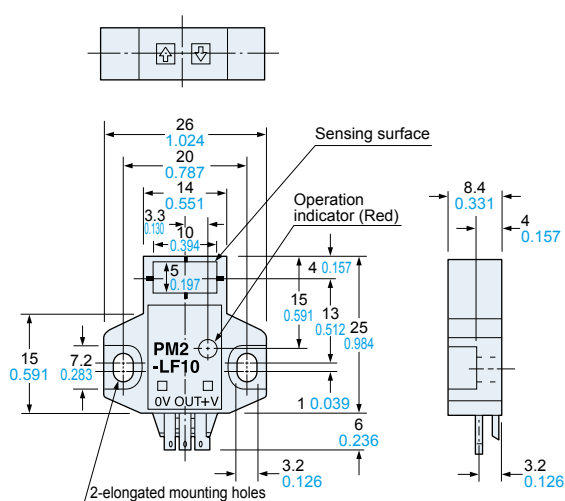

Selection Guide
U-shaped
Convergent Reflective
PM2

DIMENSIONS (Unit: mm in)

The CAD data can be downloaded from our website.

PM2-LL10 PM2-LL10B

Sensor

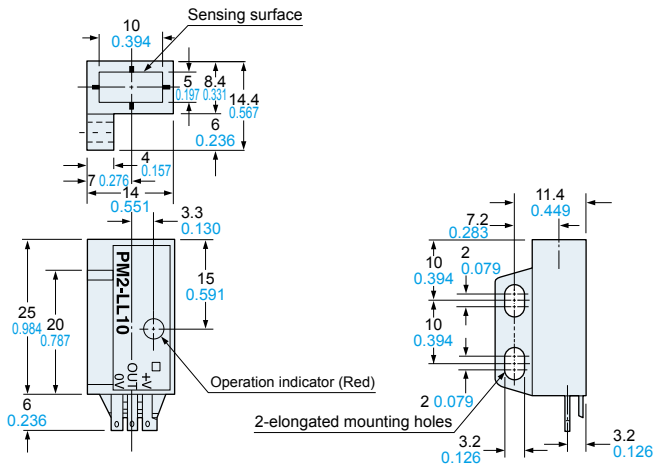

***Terminal part (Connector type)**

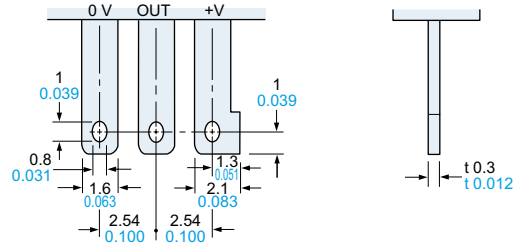

CN-13

Connector (Optional)

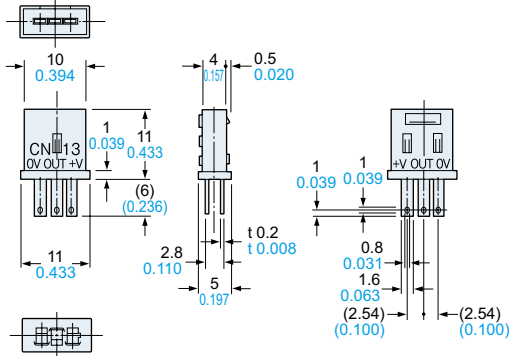

PM2-LH10-C1 PM2-LH10B-C1

Sensor

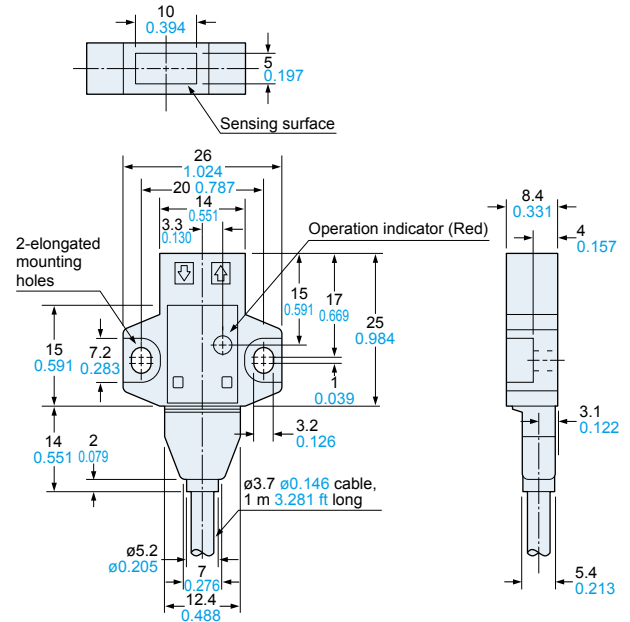

PM2-LF10-C1 PM2-LF10B-C1

Sensor

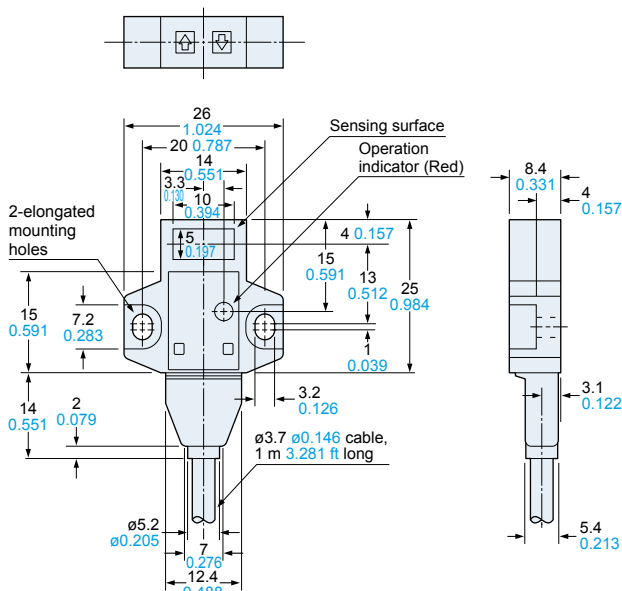

PM2-LL10-C1 PM2-LL10B-C1

Sensor

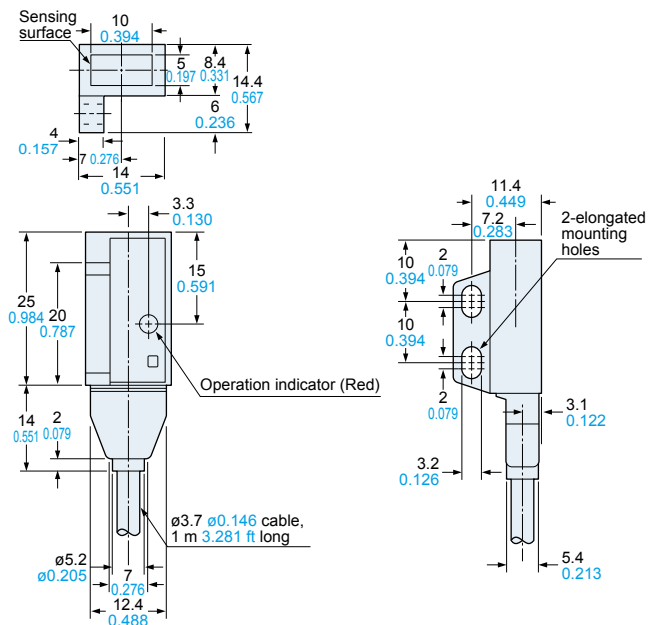

FIBER SENSORS

LASER SENSORS

PHOTO-ELECTRIC SENSORS

MICRO PHOTO-ELECTRIC SENSORS

AREA SENSORS

SAFETY LIGHT CURTAINS / SAFETY COMPONENTS

PRESSURE / FLOW SENSORS

INDUCTIVE PROXIMITY SENSORS

PARTICULAR USE SENSORS

SENSOR OPTIONS

SIMPLE WIRE-SAVING UNITS

WIRE-SAVING SYSTEMS

MEASURE-MENT SENSORS

STATIC CONTROL DEVICES

LASER MARKERS

PLC

HUMAN MACHINE INTERFACES

ENERGY MANAGEMENT SOLUTIONS

FA COMPONENTS

MACHINE VISION SYSTEMS

UV CURING SYSTEMS

Selection Guide

U-shaped

Convergent Reflective

PM2