



One Meter Works for Both Energy Saving and Power Quality Surveillance



High accuracy
0.2 %

Harmonic
measurement

Demand
management

Unbalanced
measurement*

*Advanced type

0.2 % High Accuracy, Multi-Function Power Meter

featuring demand management and power quality surveillance function in addition to the energy saving

KW9M series

Energy Saving and Demand Management

- Free of charge software for energy management "KW Watcher"
- Demand management (compliant with the IEC standard)

Power Quality Surveillance

- Harmonic measurement
- Total Harmonic Distortion (THD) measurement
- Unbalanced current and voltage measurement



* Current and voltage measurement accuracy
Active power: Class 0.5S (IEC62053-22)

Useful Functions

Multi-Function Power Meter Eco-POWER METER® KW9M SERIES

Eco-POWER METER® is a registered trademark of Panasonic Corporation. (Registered Trademark No. 5501901)

Function 1

Demand measuring function compliant with IEC61557-12 effective for energy saving

* 30-min demand method is also selectable for use in Japan.(Advanced type)

IEC demand (Sliding block interval and Fixed block interval)

Users set the time span for demand calculation to an arbitrary value between 1 to 60 minutes (in increments of one minute). The average power demand within the set span is calculated at the end of the span. [The demand values of active, reactive, apparent, active (export), and reactive (export) power are calculated.]

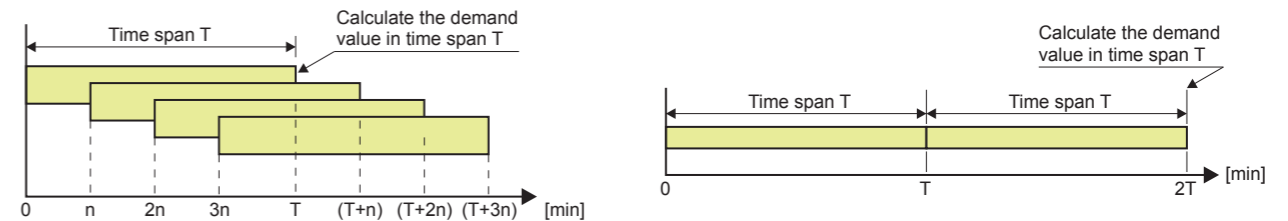

• Sliding block interval method

The next time span starts "n" minutes later. (Value "n" is arbitrarily set by users.)

• Fixed block interval method

The next time span starts after completion of the current span.

System configuration

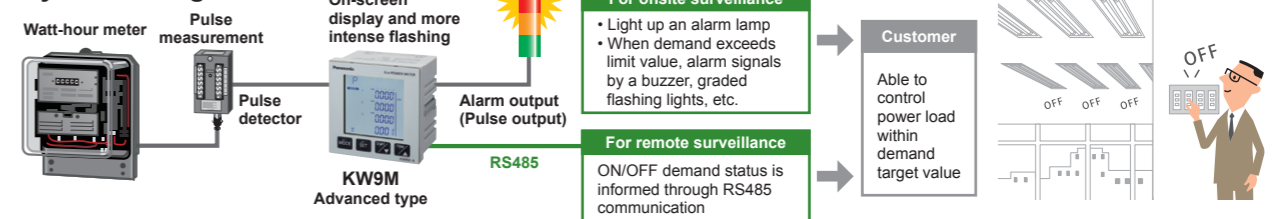

* Also ready for CT inputs (electric power measurement)

Energy Saving and Demand Management



Fields

- Factory
- Store
- Office
- Infrastructure (Freeway, railway station · facility, etc)
- Theme park

Applications

- Visualizing power consumption by department or equipment
- Monitoring for any waste of standby power
- Improving the unit consumption
- ...

Power Quality Surveillance



Fields

- Factory
- Store
- Office
- Power station
- Infrastructure (Freeway, railway station · facility, etc)
- Public facilities

Applications

- Energy-saving through demand management (compliant with the IEC standard)
- Surveillance and improving power quality
- Preventive maintenance of power equipment
- ...

Function 2

Harmonic measurement * Standard type supports THD measurement only.

Inverter equipment and fluorescent lighting fixtures are harmonic sources and can have adverse effects on precision equipment, thereby causing it to malfunction.

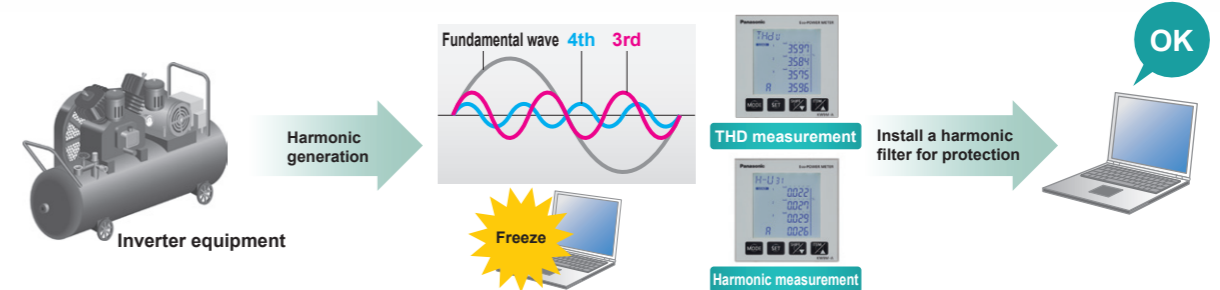

Function 3

Improvement of between phases unbalance (Advanced type)

If there is an unbalanced load due to a V-connected transformer or a heater, a voltage imbalance occurs between phases, and the motor torque becomes insufficient, causing a rise in heat or reduction in product life.

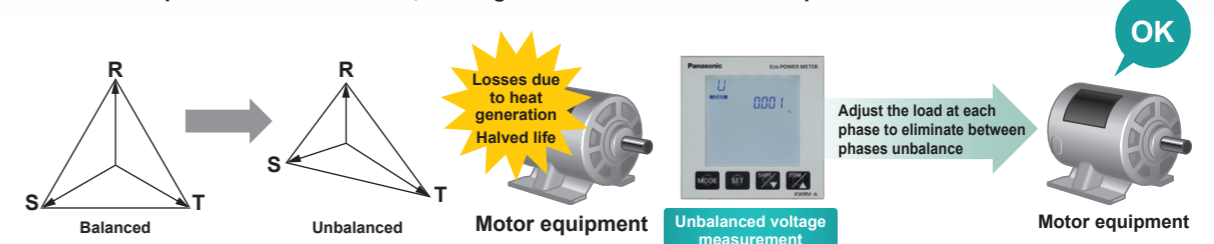

Eco-POWER METER® is a registered trademark of Panasonic Corporation. (Registered Trademark No. 5501901)

Feature 1

Large-screen LCD with backlight clearly displays the electric power of each phases and their total on one screen.

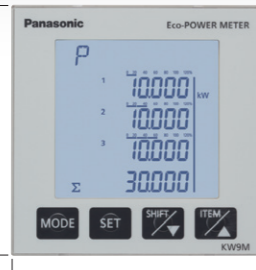

96 mm
3.780 in

Large key switches for easy operations

96 mm
3.780 in

Feature 3

Capable of simultaneously measuring up to three circuits in a single phase two-wire system of same power supply. The advanced type is also capable of N-phase measurement with the fourth CT.

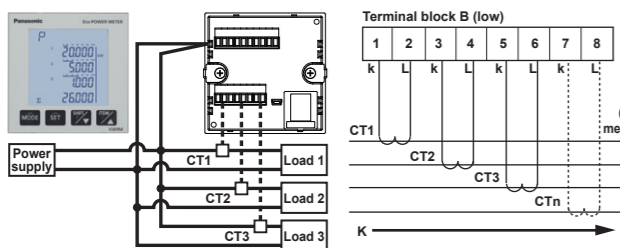

Terminal block B (low)

Terminal block C (middle) 8P

Terminal block A (top)

Terminal block B (bottom)

USB port

Battery cover

Feature 5

Various log functions available

Type	Standard	Advanced
Measurement max. value for each month	—	12 records (for 12-month)
Measurement min. value for each month (with time stamp*1)	—	12 records (for 12-month)
Max. demand value (active power, reactive power, apparent power, export active power, export reactive power, current) (with time stamp*1)*2	1 record for each, Max. value	12 records (for 12-month), Max. value
Power quality*1 (with time stamp for happening date and period)	—	Up to 10 records
	—	Up to 10 records
	—	Up to 10 records
	—	Up to 10 records
	—	Up to 10 records

*1 Time stamps and power quality data can be confirmed via communication. They are not displayed.
*2 Advanced type only

Feature 7

You can measure power with a direct connection to an already-installed large-capacity general-purpose CT (secondary side 1 A / 5 A type).

* The dedicated CT for Eco-POWER METER® cannot be used. Use a CT with a secondary side current of 1 A / 5 A.

Measuring power using the other Eco-POWER METER® series

Measuring power using large-capacity general-purpose CT

CT is not required.

The measuring accuracy of the Eco-POWER METER® does not take the CT error into account. Other Eco-POWER METER® series (except KW2M and AKW8115) need to use two CTs for measurement. KW9M is ready for direct input from only one CT, allowing higher accuracy measurements than with other Eco-POWER METER® series.

Feature 2

Capable of displaying small currents of 1 mA or above. This allows for the monitoring of standby power consumption, which helps energy saving.



1 mA or above displayable*

* Capable of measuring 0.1% or higher the rating of the secondary side of CT.

Feature 4

Equipped with input and output terminals (Advanced type)

Two pulse input points

Two pulse output points

Terminal block A (top)

Terminal block B (bottom)

Terminal block C (middle) 8P

Functions

Terminal number	1	2	3	4	5	6	7	8
Functions	OUT1	COM1	OUT2	COM2	IN1+	IN1-	IN2+	IN2-
	Output 1	Output 2	Input 1	Input 2				

Feature 6

Data can be made visualization by connecting the meter to DLL* and logging the data. Alarms can be e-mailed to mobile phones or other equipment.

*DLL is the abbreviation for Data Logger Light.

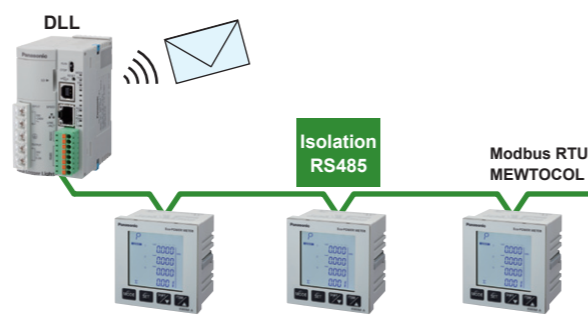

Isolation RS485

Modbus RTU, MEWTOCOL

Eco-POWER METER® is a registered trademark of Panasonic Corporation. (Registered Trademark No. 5501901)

Example of a comprehensive solution for the entire factory

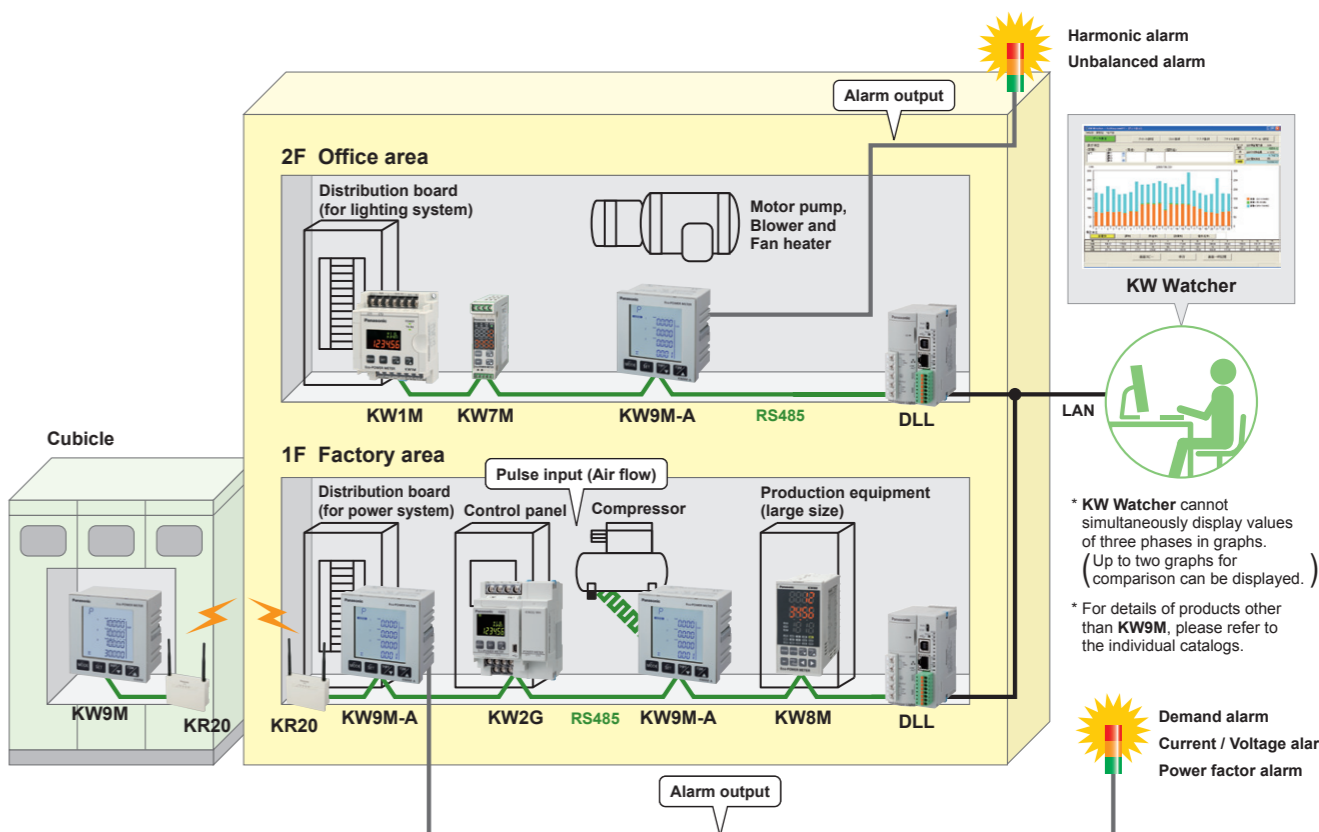

2F Office area

1F Factory area

Cubicle

Harmonic alarm

Unbalanced alarm

Alarm output

KW1M, KW7M, KW9M-A, RS485, DLL

KW9M, KR20, KW9M-A, KW2G, RS485, KW9M-A, KW8M, DLL

KW Watcher

LAN

Demand alarm

Current / Voltage alarm

Power factor alarm

* KW Watcher cannot simultaneously display values of three phases in graphs. (Up to two graphs for comparison can be displayed.)
* For details of products other than KW9M, please refer to the individual catalogs.

Free visualization software for supporting energy management

Power consumption analysis enhances equipment operation efficiency.

LANGUAGE: EN, CH, ID, VN, DE, ES, PT, KR, JP

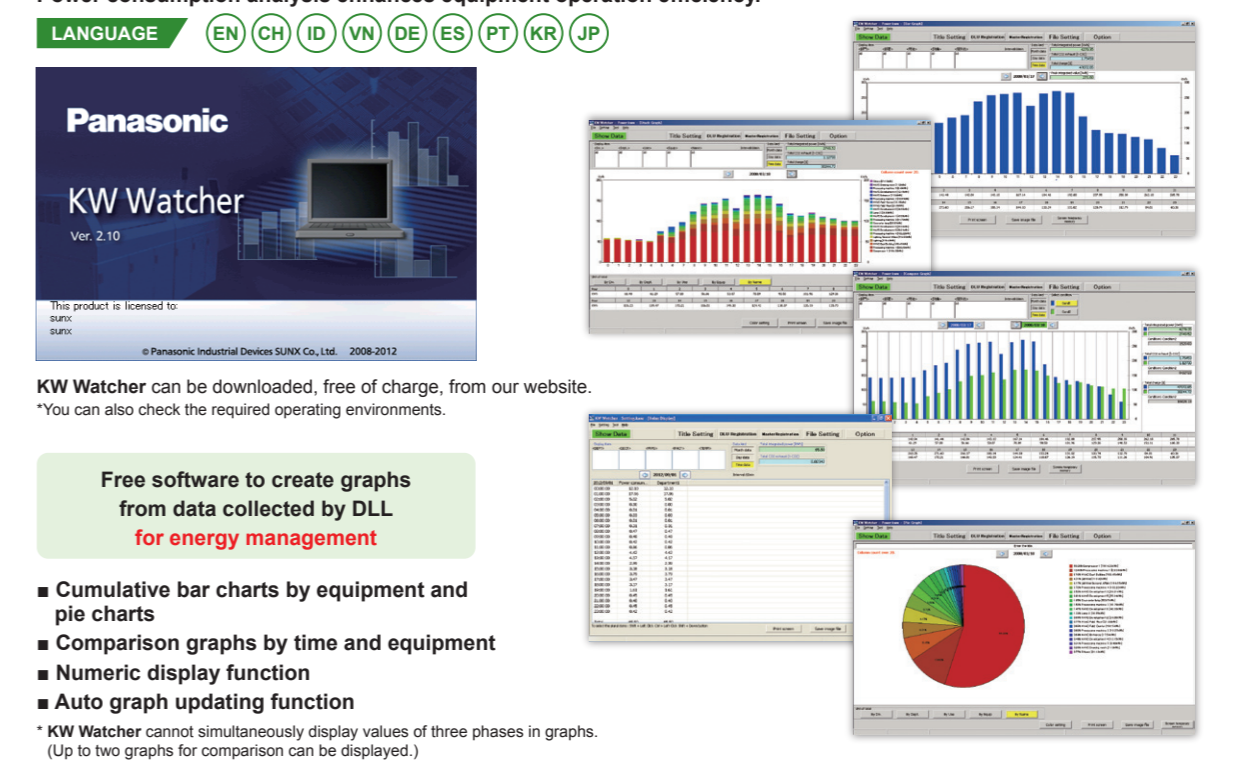

Panasonic KW Watcher Ver. 2.10

This product is licensed to: sunx

© Panasonic Industrial Devices SUNX Co., Ltd. 2008-2012

KW Watcher can be downloaded, free of charge, from our website. *You can also check the required operating environments.

Free software to create graphs from data collected by DLL for energy management

- Cumulative bar charts by equipment and pie charts
- Comparison graphs by time and equipment
- Numeric display function
- Auto graph updating function

* KW Watcher cannot simultaneously display values of three phases in graphs. (Up to two graphs for comparison can be displayed.)

Specifications

Multi-Function Power Meter
Eco-POWER METER® **KW9M** SERIES

Eco-POWER METER® is a registered trademark of Panasonic Corporation. (Registered Trademark No. 5501901)

ORDER GUIDE

Product name	Phase/Wire system	Input measurement voltage	Input measurement current	Applicable current transformer*	Model No.
KW9M Eco-POWER METER® Standard type	Single-phase two-wire (1P2W) Single-phase three-wire (1P3W) Three-phase three-wire (3P3W) Three-phase four-wire (3P4W) (common)	0 to 500 V AC (for UL 0 to 300V AC)	1 to 65,535 A	Secondary side current 1 A or 5 A	AKW91110
KW9M Eco-POWER METER® Advanced type					AKW92112

*The dedicated current transformer (CT) can not be used. Please use a CT with a secondary side 1 A / 5 A.

OVERVIEW OF FUNCTIONS

Type	Standard	Advanced
Active power	Each phase and Total (Import, Export)	
Reactive power	Each phase and Total (Import, Export)	
Apparent power	Each phase and Total	
Power demand	IEC61557-12 demand	IEC61557-12 demand 30-min demand Peak demand
Active electric energy	Each phase and Total (Import, Export)	
Reactive electric energy	Each phase and Total (Import, Export)	
Apparent electric energy	Each phase and Total	
Current	Each phase and Average current	Each phase, N-phase (when 3P4W) and Average current
Unbalanced current	—	Total (except N-phase)
Current THD	Each phase	
Current harmonics	—	Each phase (2nd to 31st harmonics)
Current demand	Each phase current demand	
Voltage	Line voltage (Each line and average), Phase voltage (Each phase and average)	
Unbalanced voltage	—	Total
Voltage THD	Line and Phase voltage	
Voltage harmonics	—	Line and Phase voltage (2nd to 31st harmonics)
Power factor	Each phase and Average	
Frequency	Each phase and Average	
Pulse count (Integral pulse)	—	2 points
Temperature	Ambient temperature	
Calendar	—	Internal clock
Input	—	2 points
Output	—	2 points

* IEC 61557-12 is an international standard on performance measuring and monitoring devices (PMD).

MEASUREMENT ITEMS

By Type

Item	Type	Unit	Display data range	Advanced		
				Present value (Instantaneous value)	Maximum	Minimum
Instantaneous power	Active	kW	-99999 to 0.000 to 99999	●	●	●
	Reactive	kvar		●	●	●
	Apparent	kVA		●	●	●
Integral power (import)	Active	kWh	0.00 to 9999999.9	●	●	—
	Reactive	kvarh		●	●	—
	Apparent	kVAh		●	●	—
Integral power for each time zone (4-zone) (import)	Active	kWh	0.00 to 9999999.9	—	●	—
	Reactive	kvarh		—	●	—
	Apparent	kVAh		—	●	—
Integral power (export)	Active	kWh	0.000 to 9999999.9	●	●	—
	Reactive	kvarh		●	●	—
	Apparent	kVAh		●	●	—
Integral power for each time zone (4-zone) (export)	Active	kWh	0.000 to 9999999.9	—	●	—
	Reactive	kvarh		—	●	—
	Apparent	kVAh		—	●	—
Current	Total	A	0.000 to 99999	●	●	●
	N-phase when 3P4W	A		—	●	●
Voltage (Phase and Line voltage)	Total	V	0.00 to 99999	●	●	●
	For each time zone	V		—	●	●
Power factor			-1.000 to 0.000 to 1.000	●	●	●
Frequency	Hz		0.00 to 99.99	●	●	●
Pulse count value	Total		0.000 to 999999999	—	●	—
	For each time zone		0.000 to 999999999	—	●	—
Temperature	degree C		-100.0 to 100.0	●	●	—
Calendar	Range		January 1, 2000 00:00:00 to Dec. 31, 2099 23:59:59	—	●	—
	Accuracy			—	●	—
	Backup				—	●

* "Display data range" is the range to be able to indicate with the main unit display, it is not a range that can be measured.

MEASUREMENT ITEMS

Power quality

Item	Unit	Display data range	Present value (Instantaneous value)	Maximum	Minimum
Unbalanced current*1	Each phase %	0.000 to 999.99	●	●	●
Unbalanced voltage*1	Each phase %	0.000 to 999.99	●	●	●
Current THD *2*4	Each phase %	0.000 to 400.00	●	—	—
Voltage THD *2*4	Each phase %	0.000 to 400.00	●	—	—
Current harmonics *1*3	Each phase %	0.000 to 400.00	●	—	—
Voltage harmonics *1*3	Phase	0.000 to 400.00	●	—	—
	Line	0.000 to 400.00	●	—	—

*1 Only advanced type *2 total harmonic distortion *3 2nd to 31st
*4 If the voltage to be measured is not the rated (commercial) frequency, it may take time for THD (total harmonic distortion) to stabilize.

Demand measurement

Item	Unit	Display data range	Present value *3	Maximum	Minimum
Present demand	Active	kW	0.000 to 99999	●	—
	Reactive	kvar		●	—
	Apparent	kVA		●	—
	Active (export)	kW		●	—
	Reactive (export)	kvar		●	—
Current	A		●	—	
Estimated demand*1*2	kW	0.000 to 99999	●	—	—
Ratio of estimated demand*1*2	%	0.000 to 99999	●	—	—
Integral power converted by pulse*1*2	kWh	0.000 to 999999.99	●	—	—

* Please use this demand function as your standard. The demand value calculated with this function is not guaranteed.

*1 Only advanced type
*2 Only when 30-min demand is set.
*3 Instantaneous value

MAIN UNIT SPECIFICATIONS

Type	Standard	Advanced
Supply voltage range	85 to 264 V AC 100 to 300 V DC	
Rated frequency	50/60 Hz	
Nominal power consumption	5 VA approx. (240 V AC at 25 °C 77 °F) 3 W approx. (240 V DC at 25 °C 77 °F)	6 VA approx. (240 V AC at 25 °C 77 °F) 3 W approx. (240 V DC at 25 °C 77 °F)
Inrush current	30 A or less (240 V AC/DC at 25 °C 77 °F)	
Allowable momentary power-off time	10 ms or less	
Ambient temperature	Accuracy guarantee: -10 to +55 °C 14 to 131 °F Operation: -25 to +55 °C -14 to 131 °F Storage: -25 to +70 °C -14 to 158 °F	
Ambient humidity	30 to 85 % RH (at 20 °C 68 °F) non-condensing	
Breakdown voltage (initial)	Between the isolated circuits: 2,000 V/1 min a) enclosure - all terminals b) between insulated circuits • power supply terminals - other terminals • RS485 terminals - other terminals • measured current input terminals - other terminals • pulse input terminals - other terminals • pulse output terminals - other terminals	Between the isolated circuits: 1,500 V/1 min a) enclosure - all terminals b) between insulated circuits • power supply terminals - other terminals • RS485 terminals - other terminals • measured current input terminals - other terminals • pulse input terminals - other terminals • pulse output terminals - other terminals
	Insulation resistance (initial)	Between the isolated circuits: 100 MΩ or more
Vibration resistance	10 to 150 Hz (7.5 minutes/cycle) single amplitude: 0.075 mm 0.0030 in (1 h on 3 axes)	
	10 to 55 Hz (1 minute/cycle) single amplitude: 0.375 mm 0.015 in (1 h on 3 axes)	
Shock resistance	Min. 294 m/s ² (5 times on 3 axes)	
Display method	LCD with backlight	
Display updating time	100 to 1000 ms (set with setting mode)	
Power failure memory method (when power OFF)	Internal memory (overwrite 10 ¹⁰ or more)	
Calendar	Range	From January 1, 2000 00:00:00 to December 31, 2099 23:59:59
	Accuracy	±15 seconds/month (at 25 °C 77 °F)
	Backup	About 1-month (backup with secondary battery) (after passing 48-hour, at 23 °C 73.4 °F)
Degree of protection	Front: IP51, Back: IP20	
Sea level altitude	Under 2,000 m 6,562 ft	
Overvoltage category	2	
Pollution degree	II	
Dimensions W/H/D	96 × 96 × 56 mm 3.78 × 3.78 × 2.20 in (without terminal block)	
	96 × 96 × 68 mm 3.78 × 3.78 × 2.68 in (with terminal block)	
Weight	450 g approx.	480 g approx. (with secondary battery)

Specifications

Multi-Function Power Meter
Eco-POWER METER® **KW9M** SERIES

Eco-POWER METER® is a registered trademark of Panasonic Corporation. (Registered Trademark No. 5501901)

MEASUREMENT SPECIFICATIONS

Type	Standard	Advanced	
Measured data	AC sine		
Phase/Wire system	Single-phase two-wire (1P2W) (max. 3-circuit), Single-phase three-wire (1P3W), Three-phase three-wire (3P3W) and Three-phase four-wire (3P4W) (Common)		
Applicable power system	100 V system, 200 V system and 400 V system		
Measured frequency	50/60 Hz		
Sampling rate	Sampling	1.024 MHz (1.0 μs approx.) / 1.024 MHz (1.0 μs approx.)	
	Date update	Harmonics 2.25s / 22.5s (2nd to 31st)	
Voltage	Input voltage	1P2W L-L 0 to 500 V AC 1P3W L-L 0 to 500 V AC L-N 0 to 250 V AC 3P3W L-L 0 to 500 V AC L-L 0 to 500 V AC L-N 0 to 289 V AC 3P4W L-L 0 to 500 V AC L-L 0 to 289 V AC	
	Impedance	2 MΩ or more (L-N: V1/V2/V3-Vn)	
	Resolution	0.01 V	
	Power consumption	0.2 VA approx. (L-N: V1/V2/V3-Vn)	
	Accuracy*1	*0.5 % for 2-phase voltage of 1P3W, 3-1 voltage of 3P3W and line voltage of 3P4W.	
	VT ratio	1.00 to 600.00 (set with setting mode) *Voltage transformer (VT) is required when you measure a load with voltage over rated voltage. (Rated secondary voltage of VT is 110 V.) *When it input direct, VT ratio is set to 1.00.	
	Current	Input current (with CT)	Primary current 65,535 A or less Secondary current 1 A or 5 A (set with setting mode)
		Max. current	10 A (200 % of the rating)
		Overload capacity	1,000 % of the rating for 3s
		Resolution	0.001 A
Power consumption		0.2 VA approx.	
Power	Accuracy*1	*0.5 % for 2 (N) - phase current of 1P3W and 2 (S) - phase current of 3P3W. 0.5 % Active power Class 0.5S (IEC 62053-22) Reactive power Class 2 (IEC 62053-23)	
	Temperature Accuracy	±5.0 °C ±1 °F (after ambient temperature correction with setting mode) Passing 2 hours or more after energized	

*1 Without error of current transformers (CT) and voltage transformers (VT)
*2 As to the current under 5 % of rating, it may not satisfy the accuracy according to CT setting (max. error: 0.5 %).
* It measures from 0.1 % of CT secondary current.
* IEC62053 is the international standard for Electricity metering equipment.

OUTPUT SPECIFICATIONS Only Advanced type

Number of output point	2 points *Insulate between output terminals	
Insulation method	PhotoMOS relay	
Output type	1a	
Output capacity	100 mA, 30 V AC/DC	
Output mode (OUT1/OUT2)	• Pulse by integral power • Output by alarm or events (set with setting mode)	
Pulse output by integral power	Pulse width	100 ms approx.
	Pulse output unit	0.0001 kWh / 0.001 kWh / 0.01 kWh / 0.1 kWh / 1 kWh / 10 kWh / 100 kWh
Alarm output Event output	Type	Stand-by power alarm / Under voltage alarm / Over voltage alarm / Power interruption alarm / Under current alarm / Over current alarm / Active power alarm / Reactive power alarm / Apparent power alarm / Power factor alarm / Over frequency alarm / Under frequency alarm / Voltage harmonics alarm / Current harmonics alarm / Voltage THD alarm / Current THD alarm / Unbalanced voltage alarm / Unbalanced current alarm / Power demand alarm / Current demand alarm / Counter output / Level output (external control)
	Alarm reset	Self-reset (according to the setting) / Manual-reset
Protection element	Varistor*	

* Varistor is mounted internal as a protection element. Install a protective device in case of using at the place where it effects by surge.

How to calculate

- Calculate the appropriate power to be measured from the unit of the integral power pulse output. Unit for pulse output > (Max. measurement power (kW)) / (3,600 sec × 1 pulse/sec)
When the pulse output unit is 0.001, the maximum power that can be properly measured by pulse output is 3.6 kW (3,600 sec × 1 pulse/sec × 0.001).
If the load is higher than this value, the output pulses cannot keep up with it, and the number of pulses becomes small.
In such cases, set the pulse output unit to the value immediately above.
- Calculate the appropriate pulse output unit from the instantaneous power to be measured. (Max. measurement power (kW)) / (3,600 sec × 1 pulse/sec) < Unit for pulse output
When the maximum power to be measured is 10 kW, the pulse output unit required for the correct pulse output is 0.01 kWh/pulse, which is the value immediately above this one: 10 W/3,600 sec × 1 pulse/sec = 0.0027

Notes:
1) If the pulse output unit is set to output one pulse or more per second, the Eco-POWER METER® cannot correctly output pulses.
2) If the pulse output OFF time is set too short, count errors by connected counters, PLCs (Programmable Logic Controllers) may occur.

INPUT SPECIFICATIONS (Only Advanced type)

Number of input point	2 points *Not insulate between input terminals (COM is common.)	
Insulation method	Designated insulation for input (insulate to the other functions)	
Input method	Contact/ non-voltage a contact or open-collector (Powered by an internal power supply)	
Input signal	Non-voltage input	• Impedance; Max. 1 kΩ (when short-circuit current; Max. 10 mA) • Residual voltage when shorted; Max. 3 V • Impedance when open; Min. 100 kΩ
	Input mode	IN1 Pulse input or synchronized with output from outer device IN2 Pulse input
Max. counting speed	IN1	30 Hz (when pulse input)
	IN2	2000 Hz / 30 Hz
Min. input signal width	IN1	16.7 ms ON:OFF ratio = 1:1
	IN2	0.25 ms (when 2000 Hz is set) / 16.7 ms (when 30 Hz is set) ON:OFF ratio = 1:1
Pre-scale	Decimal point	Under 3-digit
	Range	0.001 to 100.000 (set with setting mode)
Output mode (when pulse output is selected)	HOLD	
Protective elements	Zener diode	

DEMAND MONITOR AND CONTROL SPECIFICATIONS AKW91110 supports only marked items (●)

Demand type	• Peak demand • IEC61557-12 demand (●) 1. Sliding block interval demand 2. Fixed block interval demand 3. Current demand • 30-min demand (set with setting mode)	
	Demand monitor input type	Current transformer (CT) input (IEC demand / 30-min demand) (●) Integral pulse input (only 30-min demand) (set with setting mode)
Demand time span*1	IEC61557-12 demand (●) 30-min demand	1 to 60 min. (set with setting mode) 30 min. (fixed)
	Demand measurement item	Present demand, Estimated demand (only 30-min demand)
Demand calculate method*2		Additional method / Average method (set with setting mode)
	Demand data update cycle (●)	1 min
Demand stand-by time (mask time)*		1 to 30 min. (set with setting mode)
	Display	IEC61557-12 demand (●) 30-min demand
Saved data	Monthly max. demand 12 records (12-month), Max.demand (●)	
Time span synchronized method	Clock synchronized (Pulse input to IN1) (set with setting mode)	
Synchronized signal input <IN1>	Input terminal	IN1
	Input method	Non-voltage a contact or open-collector (Powered by an internal power supply)
Pulse input <IN2>	Input terminal	IN2
	Input method	Non-voltage a contact or open-collector (Powered by an internal power supply)
Pulse input condition	Pulse input signal	50,000 pulse/kWh <An external pulse detector required> 2,000 pulse/kWh <An external pulse converter required>
	Pulse rate	0.001 to 100.000 kWh/pulse
Pulse input condition	Pulse width	0.25 ms or more
	Pulse interval	0.5 ms or more (OFF: 0.25 ms or more)
Operating voltage/current	Pulse width	16.7 ms or more
	Pulse interval	33.4 ms or more (OFF: 16.7 ms or more)
Signal common	Common (IN1; common to clock synchronized input)	

*1 The time span can be arbitrarily set only for sliding block interval demand and fixed block interval demand.
*2 Available when 30-min demand is selected.

COMMUNICATION SPECIFICATIONS

Interface	Conforming to RS485	
Communication method	Half-duplex	
Synchronous system	Synchronous communication method	
Isolation status	Isolated with the internal circuits	
Protocol	MEWTCCOL, MODBUS (RTU), DL/T645-2007*1 (select with setting mode)	
Number of connected unit	99 (max.) *2	
Transmission distance	1,200 m 3,937 ft *3	
Transmission speed		38,400, 19,200, 9,600, 4,800, 2,400, 1,200 bps (select with setting mode)
	Data length	8bit (fixed)
Transmission format	Parity	Not available / odd number / even number (select with setting mode)
	Stop bit	1bit, 2bit (select with setting mode)

*1 MEWTCCOL is the protocol for PLC from Panasonic. DL/T645 is the China power-meter standard. Only DL/T645-2007 is supported.
*2 For RS485 converter on the computer side, we recommend SI-35 and SI-35USB (from LINE EYE Co., Ltd.). When using SI-35, SI-35USB or PLC from our company (which can be connected up to 99 units), up to 99 can be connected.
In case using this system with the other devices, up to 31 can be connected.
*3 Please check with the actual devices when some commercial devices with RS485 interface are connected. The number of connected devices, transmission distance, and transmission speed may be different according to using transmission line.

Dimensions

Multi-Function Power Meter **KW9M** SERIES
Eco-POWER METER®

EXTERNAL DIMENSIONS

(Unit: mm in)

Eco-POWER METER® is a registered trademark of Panasonic Corporation. (Registered Trademark No. 5501901)

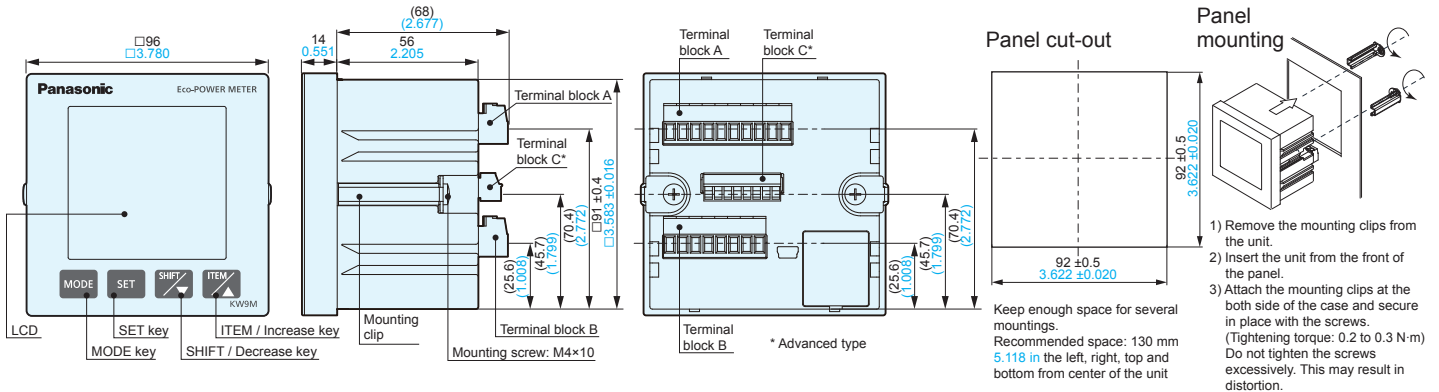

TERMINAL ARRANGEMENT AND WIRING DIAGRAMS

Terminal wiring

- Be sure to wire correctly according to the terminal arrangement and wiring diagrams.
- Please connect a fuse or a breaker to power supply part for safety reasons, to protect the device and ease of maintenance. This has no built-in power switch, circuit breaker or fuse for measured voltage input parts. Therefore it is necessary to install them in the circuit near this unit.
- Do not turn on the power supply or input until all wiring is completed.
- Do not open the secondary side of CT while the primary side current is energized. Do not remove the terminal block while the primary side current of CT is energized. These actions may result in electric shock or CT breakdown.

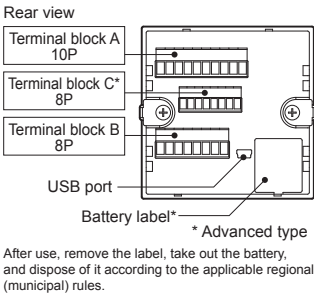

Specifications of terminal block A/B
Screw size: M2.5
Tightening torque: 0.4 to 0.5 N·m
Applicable wire: (Crimp-type terminal is recommended.)
• Single wire 0.13 to 4 mm² (AWG26 to 12)
• Stranded wire 0.2 to 4 mm² (AWG24 to 12)
• for 2 pcs.
Single wire / Stranded wire 2 pcs.
0.5 to 2.1 mm² (AWG20 to 14)

Specifications of terminal block C
Screw size: M2.0
Tightening torque: 0.2 to 0.25 N·m
Applicable wire: (Crimp-type terminal is recommended.)
• Single wire 0.08 to 1.5 mm² (AWG28 to 16)
• Stranded wire 0.2 to 1.5 mm² (AWG24 to 16)
Stripping length: 7 to 8 mm 0.276 to 0.315 in

Terminal arrangement

Terminal block A (upper) 10P

Terminal number	1	2	3	4	5	6	7	8	9	10
Functions	L+	N-	V1	V2	V3	Vn	NC	SG	A+	B-
	AUX (Power supply)		Measured voltage input			Vacant	RS485			

Terminal block C (middle) 8P (Only Advanced type)

Terminal number	1	2	3	4	5	6	7	8
Functions	OUT1	COM1	OUT2	COM2	IN1+	IN1-	IN2+	IN2-
	Output 1		Output 2		Input 1		Input 2	

Terminal block B (lower) 8P

Terminal number	1	2	3	4	5	6	7*	8*
Functions	CT1	CT1	CT2	CT2	CT3	CT3	CTn	CTn
	Measured current input							

* The N-phase measurement is available for the advanced type only.

Wiring diagrams

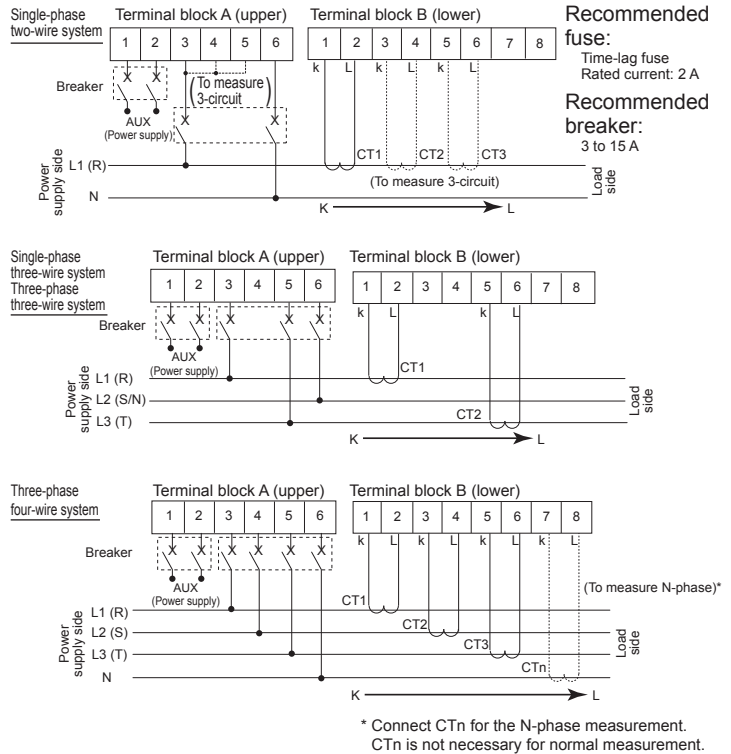

Recommended fuse:
Time-lag fuse
Rated current: 2 A

Recommended breaker:
3 to 15 A

Please contact

Panasonic Industrial Devices SUNX Co., Ltd.

2431-1 Ushiyama-cho, Kasugai-shi, Aichi, 486-0901, Japan
Global Sales Department

■ Telephone: +81-568-33-7861 ■ Facsimile: +81-568-33-8591
panasonic.net/id/pidsx/global



All Rights Reserved ©Panasonic Industrial Devices SUNX Co., Ltd. 2016