

617-960 MHz / 1350-2700 MHz / 3300-3800 MHz / 4900-6000 MHz Low PIM
Rated H-pol Ceiling Omni Antenna, Low Profile, Type N Female Connector



HG65806CUPR-NF

Features

- Low Passive Intermodulation (PIM) <-153 dBc @ 2x20W
- Horizontal Polarization
- Low Profile 3/4" thick antenna
- Type N Female connector with 12 inch pigtail
- Covers all sub 6 GHz 5G frequency bands including 600 MHz and extended CBRS

Applications

- Indoor distribution of 5G, LTE, GSM/CDMA
- In-building public or private networks
- LPWAN, LoRA, LTE-M, NB-IoT, IoT, M2M applications
- DAS (Distributed Antenna Systems)
- Discrete Ceiling Mounts

Description

The L-com HG65806CUPR-NF is a low PIM rated, high performance ceiling mount omnidirectional antenna specifically designed for in-building wireless networks such as DAS (Distributed Antenna Systems). L-com's HG65806CUPR-NF has 1.5 to 6 dBi gain and can be used to distribute Cellular and WiFi signals throughout a building or area. The HG65806CUPR-NF operates from 617 to 6000 MHz which is ideal for 5G, LTE, CDMA, LPWAN/IoT/M2M applications including LoRA, LTE-M, and NB-IOT. The Multi-Band design of the L-com HG65806CUPR-NF antenna eliminates the need to purchase different antennas for each frequency. This simplifies installations since the same antenna can be used for a wide array of in-building wireless applications where wide coverage is desired.

The HG65806CUPR-NF from L-com has omnidirectional patterns with horizontal polarization and features Type N connectors. The key to providing the best performance in telecommunications is to ensure the components used are low PIM rated. This helps meet the increasing demand for higher data rates and the ability to provide streaming video for mobile devices. With a low PIM rating of <-150 dBc, the 617-6000 MHz HG65806CUPR-NF helps meets the most demanding PIM requirements for 5G and LTE/4G bands.

The Type N connectorized HG65806CUPR-NF antenna from L-com is designed specifically for in-building operation and is ideal for use in large open areas such as indoor courtyards, indoor sporting venues, convention centers and shopping malls. The included mounting bracket and hardware makes this antenna very easy to install. This 5G Cellular antenna just like our wide selection of superior quality RF parts, ship same day. Contact our knowledgeable and friendly technical support and sales staff for your answers on antennas or other L-com products.

Configuration

Design	Ceiling
Band Type	Wide
Radiation Pattern	Omni Directional
Polarization	Linear
Connector Type	N Female
Number of Ports	1

Electrical Specifications

Description	Minimum	Typical	Maximum	Units
Frequency Range	617		6000	MHz
Input VSWR			1.8:1	

Click the following link (or enter part number in "SEARCH" on website) to obtain additional part information including price, inventory and certifications:
[617-960 MHz / 1350-2700 MHz / 3300-3800 MHz / 4900-6000 MHz Low PIM Rated H-pol Ceiling Omni Antenna, Low Profile, Type N Female Connector](#)

617-960 MHz / 1350-2700 MHz / 3300-3800 MHz / 4900-6000 MHz Low PIM
Rated H-pol Ceiling Omni Antenna, Low Profile, Type N Female Connector



HG65806CUPR-NF

Impedance	50	Ohms
Gain	1.5	dBi
Gain	6	dBi
Input Power	50	Watts
Passive Intermodulation 3rd Order, 2 x 20 W	-153	

Specifications by Band

Description	Band 1	Band 2	Band 3	Band 4	Band 5	Units
Range	0.617 to 0.96	1.35 to 1.55	1.69 to 2.7	3.3 to 3.8	4.9 to 6	GHz
Gain	2.2	3.5	4.5	6	6	dBi
VSWR Max	1.8:1	1.8:1	1.8:1	1.8:1	1.8:1	

Mechanical Specifications

Radome Material	ABS
Size	
Length	8.66 in [219.96 mm]
Width	8.66 in [219.96 mm]
Height	0.71 in [18.03 mm]
Weight	0.66 lbs [299.37 g]

Environmental Specifications

Temperature	
Operating Range	-55 to +60 deg C
Humidity	< 95

Compliance Certifications (see [product page](#) for current document)

Plotted and Other Data

Notes:

617-960 MHz / 1350-2700 MHz / 3300-3800 MHz / 4900-6000 MHz Low PIM Rated H-pol Ceiling Omni Antenna, Low Profile, Type N Female Connector from L-com has same day shipment for domestic and International orders. Our portfolio includes coaxial cable assemblies, connectors, adapters and custom products as well as lightning and surge protectors, NEMA rated enclosures, and an RF

617-960 MHz / 1350-2700 MHz / 3300-3800 MHz / 4900-6000 MHz Low PIM
Rated H-pol Ceiling Omni Antenna, Low Profile, Type N Female Connector



HG65806CUPR-NF

product line which includes antennas, amplifiers, passive, and active components.

The information contained within this document is accurate to the best of our knowledge and representative of the part described herein. It may be necessary to make modifications to the part and/or the documentation of the part in order to implement improvements. L-com reserves the right to make such changes as required. Unless otherwise stated, all specifications are nominal. L-com does not make any representation or warranty regarding the suitability of the part described herein for any particular purpose, and L-com does not assume liability arising out of the use of any part or document.

617-960 MHz / 1350-2700 MHz / 3300-3800 MHz / 4900-6000 MHz Low PIM Rated
H-pol Ceiling Omni Antenna, Low Profile, Type N Female Connector

L-com CAD Drawing

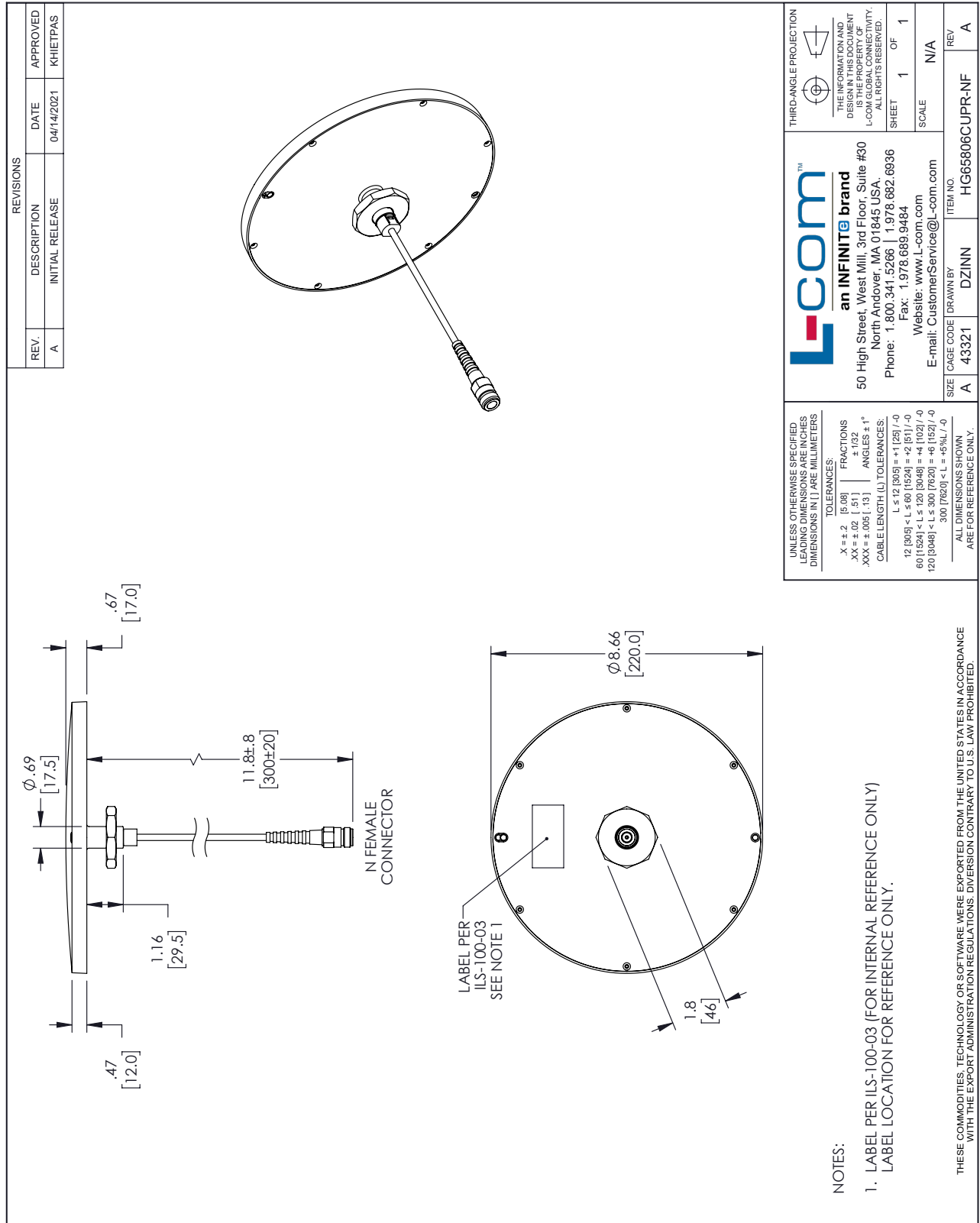

UNLESS OTHERWISE SPECIFIED LEADING DIMENSIONS ARE IN INCHES DIMENSIONS IN [] ARE MILLIMETERS

TOLERANCES:

.X ± .2 [5.08]	FRACTIONS ± 1/32
.XX ± .02 [.51]	ANGLES ± 1°
.XXX ± .005 [.13]	

CABLE LENGTH (L) TOLERANCES:

L ≤ 12 [305]	L ≤ 60 [1524]	L ≤ 125 [3175]	L ≤ 150 [3810]
12 [305] < L ≤ 60 [1524]	60 [1524] < L ≤ 120 [3048]	120 [3048] < L ≤ 300 [7620]	300 [7620] < L = +5% / -0

ALL DIMENSIONS SHOWN ARE FOR REFERENCE ONLY.

L-com™
an INFINITE brand

50 High Street, West Mill, 3rd Floor, Suite #30
North Andover, MA 01845, USA.
Phone: 1.800.341.5266 | 1.978.682.6936
Fax: 1.978.689.9484
E-mail: CustomerService@l-com.com
Website: www.l-com.com

THIRD-ANGLE PROJECTION

THE INFORMATION AND DIMENSIONS SHOWN ARE THE PROPERTY OF L-COM GLOBAL CONNECTIVITY. ALL RIGHTS RESERVED.

SHEET 1 OF 1

SCALE N/A

SIZE	CAGE CODE	DRAWN BY	ITEM NO.
A	43321	DZINN	HG65806CUPR-NF
			REV
			A

NOTES:

- LABEL PER ILS-100-03 (FOR INTERNAL REFERENCE ONLY)
LABEL LOCATION FOR REFERENCE ONLY.