

Specification

- Part No. : **GA.130.201111**
- Product Name : Shanghai Magnetic Mount
698-2700MHz LTE Antenna
- Feature : Dipole Terminal Antenna
4G/3G/2G LTE Antenna
698-2700MHz
Highest Efficiency
2m RG-174 Cable with SMA(M) Connector
Ingress Protection Rating IP65
Dimensions: Base: 72x53 * Height :143mm
RoHS & REACH Compliant



1. Introduction

The Shanghai GA.130 4G magnetic wideband cellular antenna delivers stable, omni-directional gain and highest efficiencies across all common 4G, 3G & 2G global cellular bands from 698 MHz to 2.7 GHz. This sculpted high performing antenna can be used for all cellular devices and will not require changing antennas when deploying from most major markets worldwide such as 4G to 3G. This antenna can either be mounted magnetically on a metal surface or via the 3M adhesive if non-metal surfaces.

A reliable return loss of <10dB, when mounted on a metal plate, ensures the antenna complies with the industry standards set by module makers and networks worldwide.

Taoglas recommends using the antenna with 2m cable length or less and can provide customized connectors and cable lengths upon customer request. The strong magnetic base is extremely stable and robust, using only high-quality neodymium magnets for a secure magnetic mount to ensure a high pull force to disengage.

An adhesive mount, GA.131.201111 and permanent mount option, GA.132.201111 are also available upon request. For further information, please contact your regional Taoglas sales office for support.

2. Specification

Electrical								
Frequency (MHz)		LTE700	GSM850	GSM900	DCS	PCS	UMTS1	LTE2600
		698~806	824~894	880~960	1710~1880	1850~1900	1920~2170	2300~2690
Efficiency (%)								
Free Space	0.3m	70.29	83.08	74.93	62.56	69.68	71.42	71.85
	1m	62.44	72.36	65.27	51.35	57.02	58.05	56.44
	2m	52.24	60.00	53.25	38.66	42.72	43.14	40.50
	3m	43.63	49.41	43.88	29.26	31.82	31.98	28.86
On 50x50cm Ground Plane	0.3m	80.74	77.24	63.63	59.49	63.39	64.84	67.79
	1m	71.74	67.27	55.39	48.87	51.91	52.71	53.25
	2m	60.07	55.79	45.19	36.78	38.88	39.15	38.16
	3m	50.18	45.95	37.22	27.83	28.97	29.02	27.20
Average Gain (dB)								
Free Space	0.3m	-1.53	-0.81	-1.25	-2.04	-1.57	-1.46	-1.44
	1m	-2.05	-1.41	-1.85	-2.89	-2.44	-2.36	-2.48
	2m	-2.82	-2.22	-2.74	-4.13	-3.69	-3.65	-3.93
	3m	-3.60	-3.06	-3.58	-5.34	-4.97	-4.95	-5.40
On 50x50cm Ground Plane	0.3m	-0.93	-1.12	-1.96	-2.26	-1.98	-1.88	-1.69
	1m	-1.44	-1.72	-2.57	-3.11	-2.85	-2.78	-2.74
	2m	-2.21	-2.53	-3.45	-4.34	-4.1	-4.07	-4.18
	3m	-2.99	-3.38	-4.29	-5.55	-5.38	-5.37	-5.66
Peak Gain (dBi)								
Free Space	0.3m	2.43	2.20	2.19	2.47	3.25	3.62	5.57
	1m	1.93	1.60	1.59	1.67	2.35	2.72	4.47
	2m	1.13	0.80	0.69	0.37	1.15	1.32	3.07
	3m	0.43	0.00	-0.11	-0.83	-0.15	0.02	1.57
On 50x50cm Ground Plane	0.3m	3.40	3.15	3.10	3.58	3.38	3.38	4.26
	1m	2.90	2.55	2.50	2.68	2.58	2.48	3.25
	2m	2.10	1.75	1.60	1.48	1.28	1.18	1.85
	3m	1.30	0.95	0.70	0.28	0.08	-0.12	0.45
Impedance		50Ω						
Polarization		Linear						
Radiation Pattern		Omni						
Input Power		10 W						

Mechanical	
Casing	UV Stabilized ASA
Connector	SMA (M) Straight
Cable	2M RG-174
Dimensions	Base: 72x53mm * Height: 143mm
IP Rating	IP65
Weight	145g
Magnetic Pull Force	0.8Kg
Mounting Type	Adhesive Mount (3M 467) / Magnetic Mount
Environmental	
Storage Temperature	-40°C to +85°C
Operating Temperature	-40°C to +85°C
Humidity	Non-condensing 65°C 95% RH

LTE BANDS				
Band Number	LTE / LTE-Advanced / WCDMA / HSPA / HSPA+ / TD-SCDMA			
	Uplink	Downlink	Covered	Covered
1	UL: 1920 to 1980	DL: 2110 to 2170	✓	✓
2	UL: 1850 to 1910	DL: 1930 to 1990	✓	✓
3	UL: 1710 to 1785	DL: 1805 to 1880	✓	✓
4	UL: 1710 to 1755	DL: 2110 to 2155	✓	✓
5	UL: 824 to 849	DL: 869 to 894	✓	✓
7	UL: 2500 to 2570	DL: 2620 to 2690	✓	✓
8	UL: 880 to 915	DL: 925 to 960	✓	✓
9	UL: 1749.9 to 1784.9	DL: 1844.9 to 1879.9	✓	✓
11	UL: 1427.9 to 1447.9	DL: 1475.9 to 1495.9	✗	✗
12	UL: 699 to 716	DL: 729 to 746	✓	✓
13	UL: 777 to 787	DL: 746 to 756	✓	✓
14	UL: 788 to 798	DL: 758 to 768	✓	✓
17	UL: 704 to 716	DL: 734 to 746 (LTE only)	✓	✓
18	UL: 815 to 830	DL: 860 to 875 (LET only)	✓	✓
19	UL: 830 to 845	DL: 875 to 890	✓	✓
20	UL: 832 to 862	DL: 791 to 821	✓	✓
21	UL: 1447.9 to 1462.9	DL: 1495.9 to 1510.9	✗	✗
22	UL: 3410 to 3490	DL: 3510 to 3590	✗	✗
23	UL: 2000 to 2020	DL: 2180 to 2200 (LTE only)	✓	✓
24	UL: 1625.5 to 1660.5	DL: 1525 to 1559 (LTE only)	✗	✗
25	UL: 1850 to 1915	DL: 1930 to 1995	✓	✓
26	UL: 814 to 849	DL: 859 to 894	✓	✓
27	UL: 807 to 824	DL: 852 to 869 (LTE only)	✓	✓
28	UL: 703 to 748	DL: 758 to 803 (LTE only)	✓	✓
29	UL: -	DL: 717 to 728 (LTE only)	✓	✓
30	UL: 2305 to 2315	DL: 2350 to 2360 (LTE only)	✓	✓
31	UL: 452.5 to 457.5	DL: 462.5 to 467.5 (LTE only)	✗	✗
32	UL: -	DL: 1452 - 1496	✗	✗
35		1850 to 1910	✓	✓
38		2570 to 2620	✓	✓
39		1880 to 1920	✓	✓
40		2300 to 2400	✓	✓
41		2496 to 2690	✓	✓
42		3400 to 3600	✗	✗
43		3600 to 3800	✗	✗

*Covered bands represent an efficiency greater than 20%

3. Antenna Characteristics

3.1 Return Loss

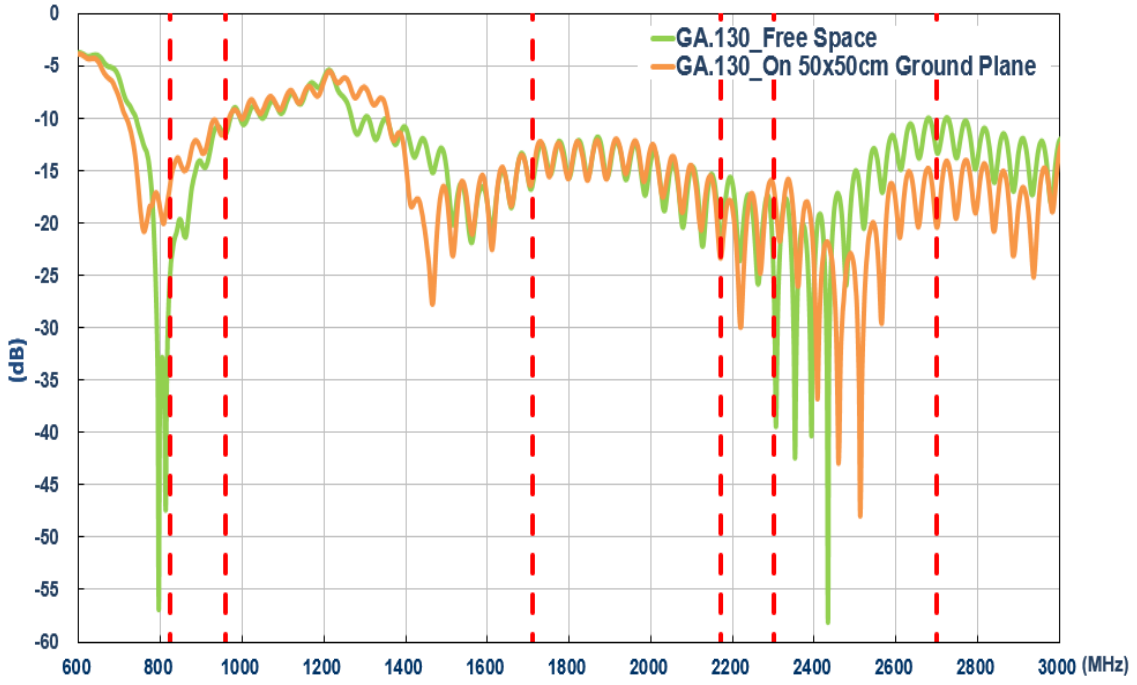

3.2 Efficiency

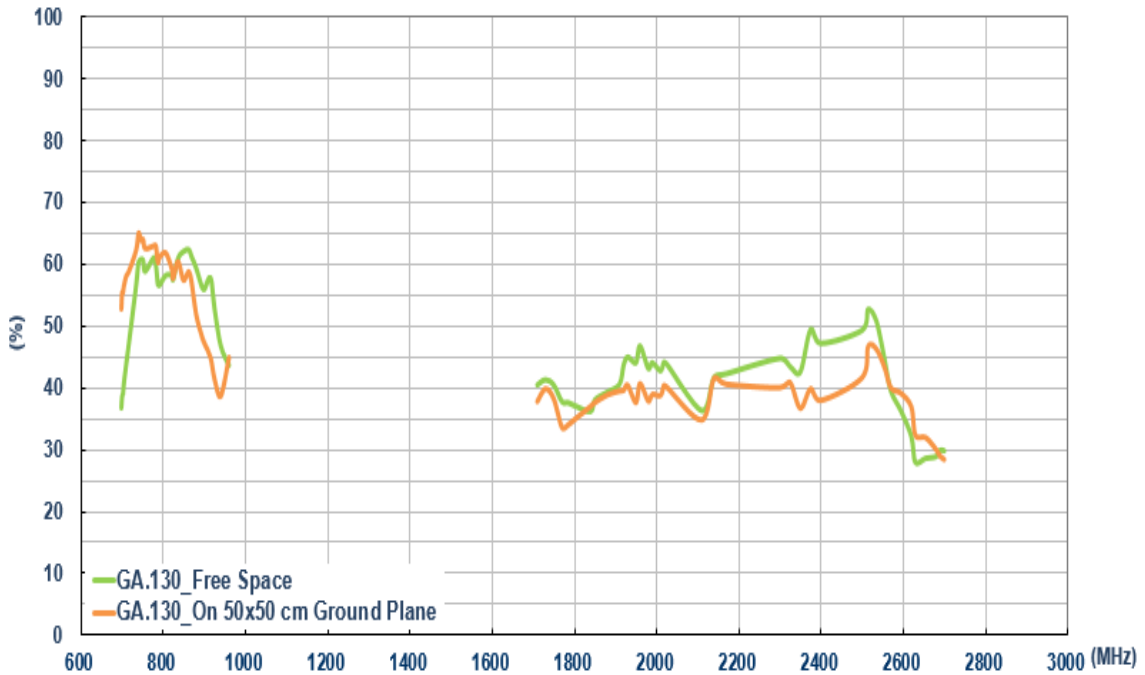

3.3 Average Gain

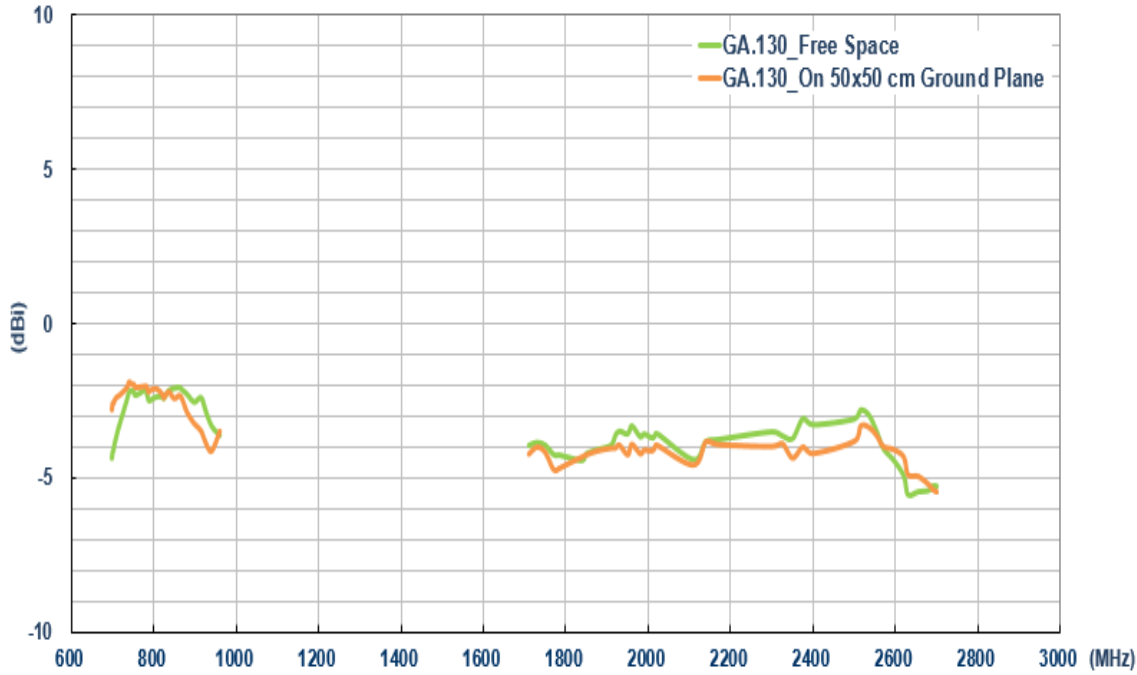

3.4 Peak Gain

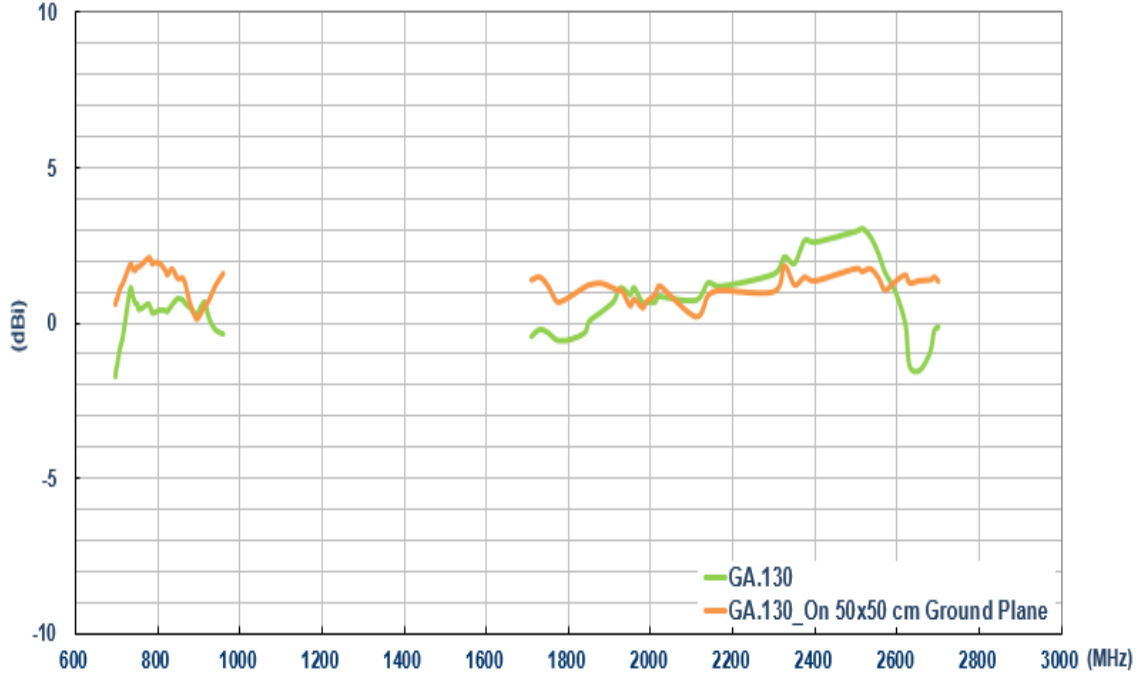

3.5 Test Setup For Antenna Radiation Pattern

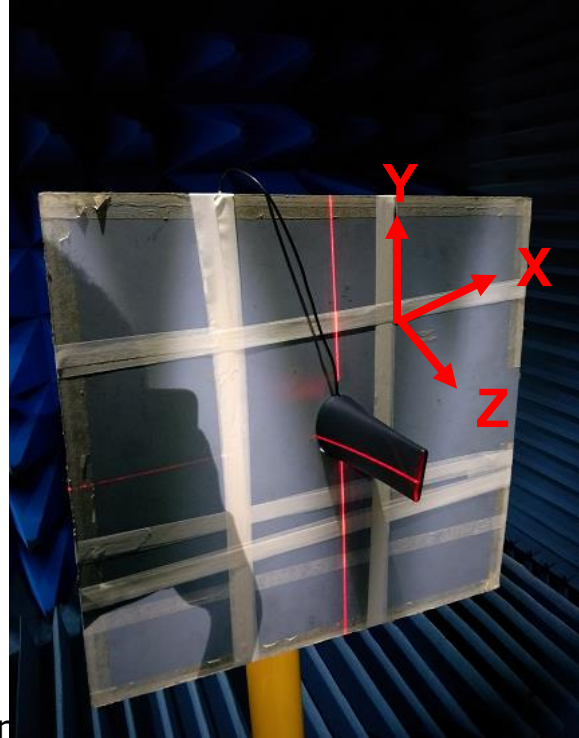
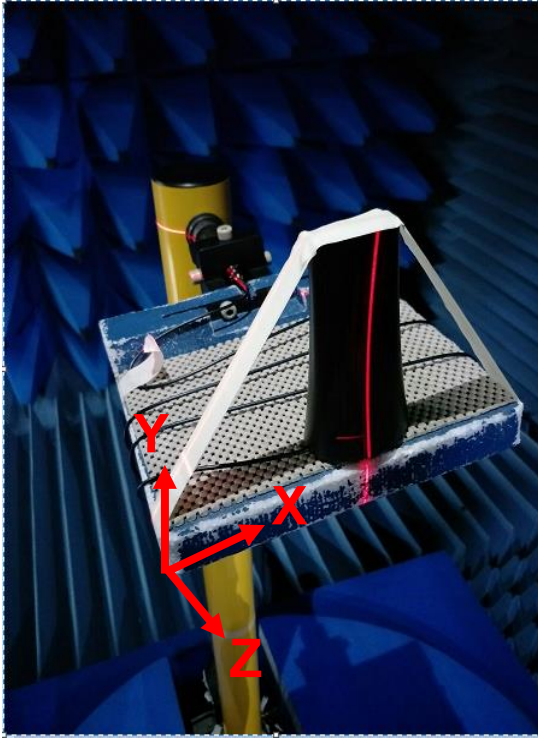

3.5.1 2D Radiation Pattern (Free Space)

XY Plane

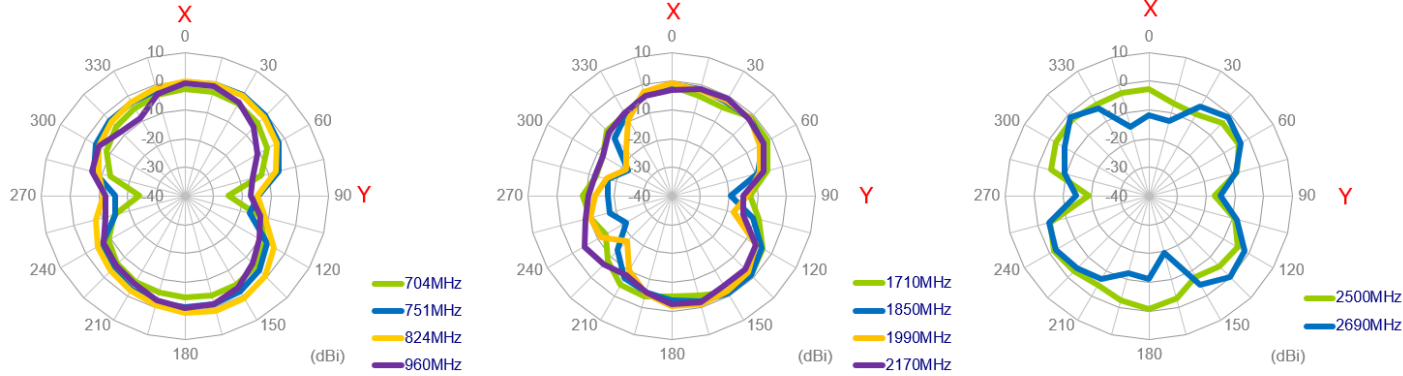

XZ Plane

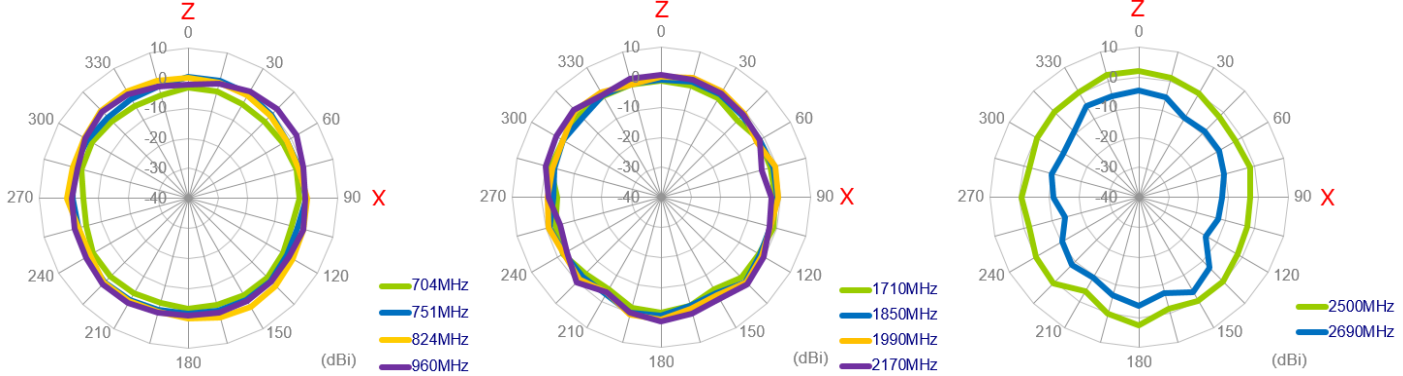

YZ Plane

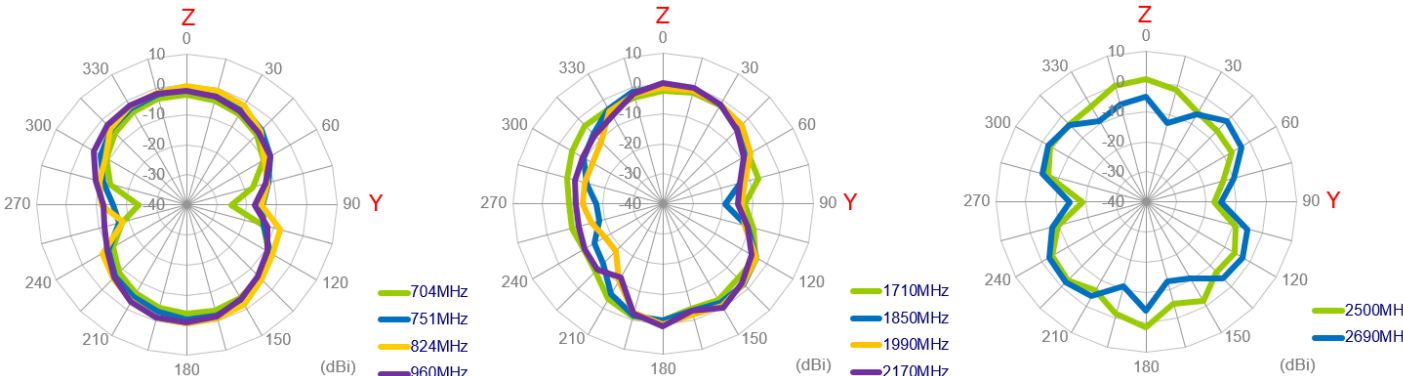

3.5.2 2D Radiation Pattern (On 50x50cm Ground Plane)

XY Plane

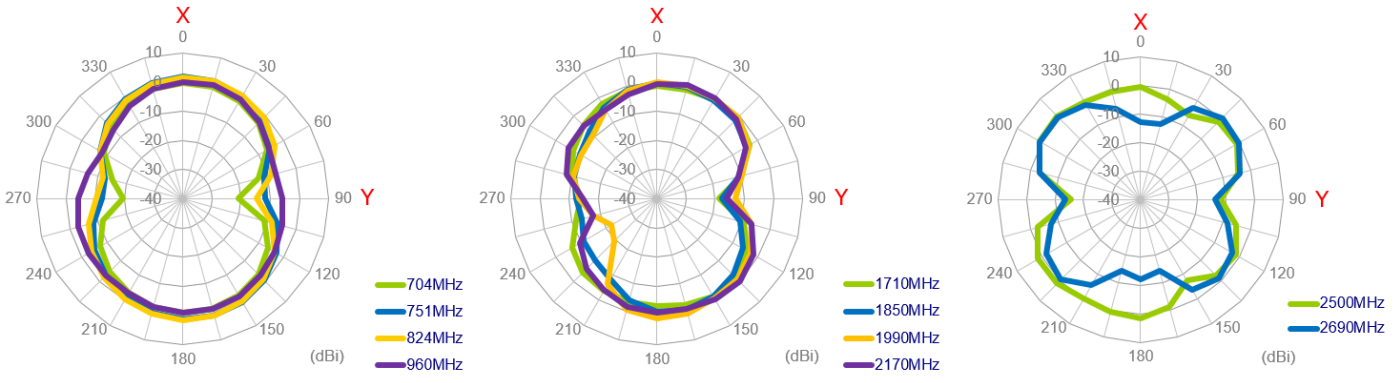

XZ Plane

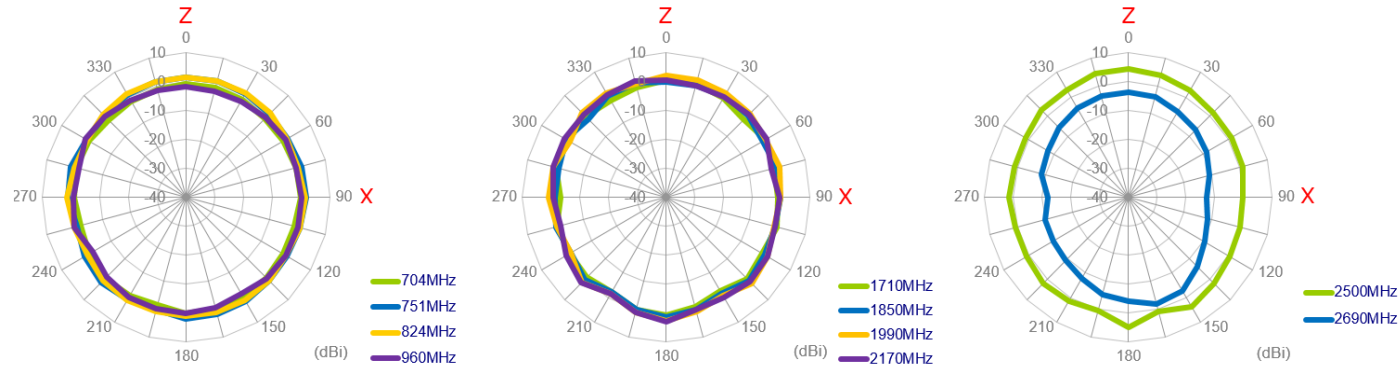

YZ Plane

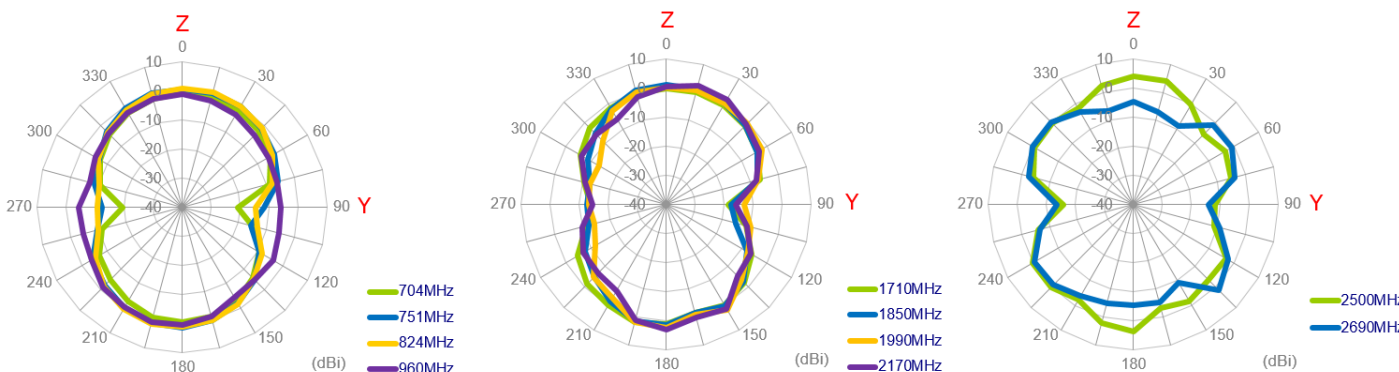

3.5.3 3D Radiation Pattern (Free Space)

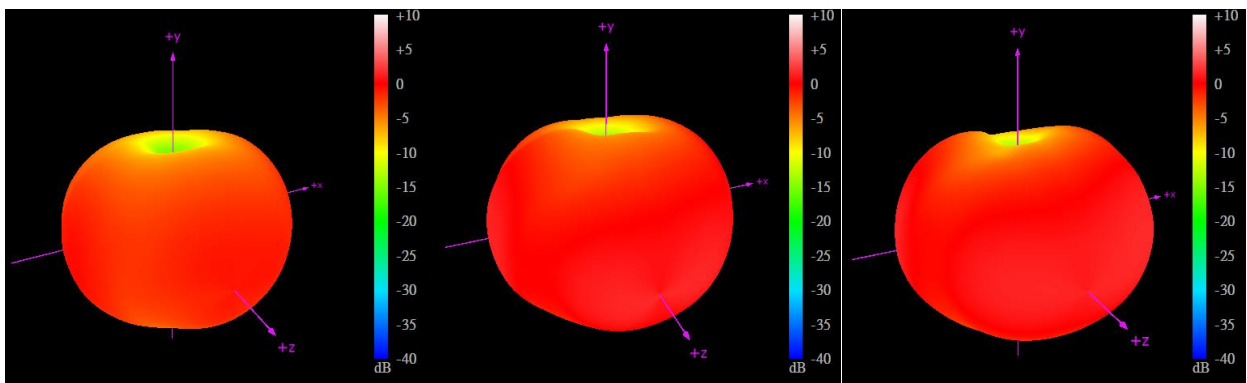

704MHz

751MHz

824MHz

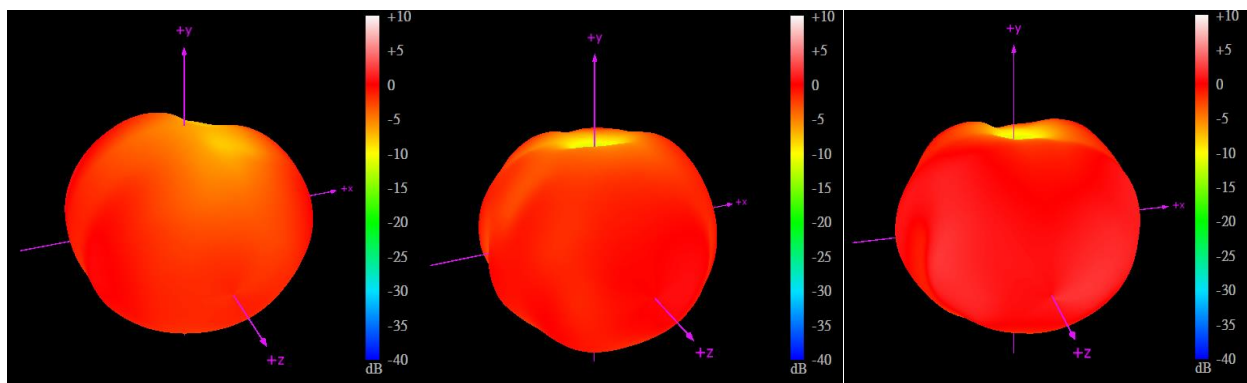

960MHz

1710MHz

1990MHz

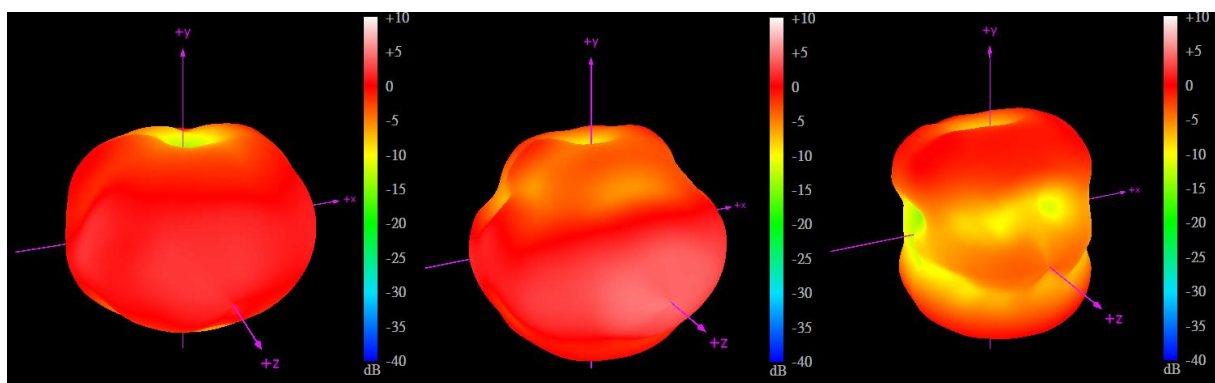

2170MHz

2500MHz

2690MHz

3.5.4 3D Radiation Pattern (On 50x50cm Ground Plane)

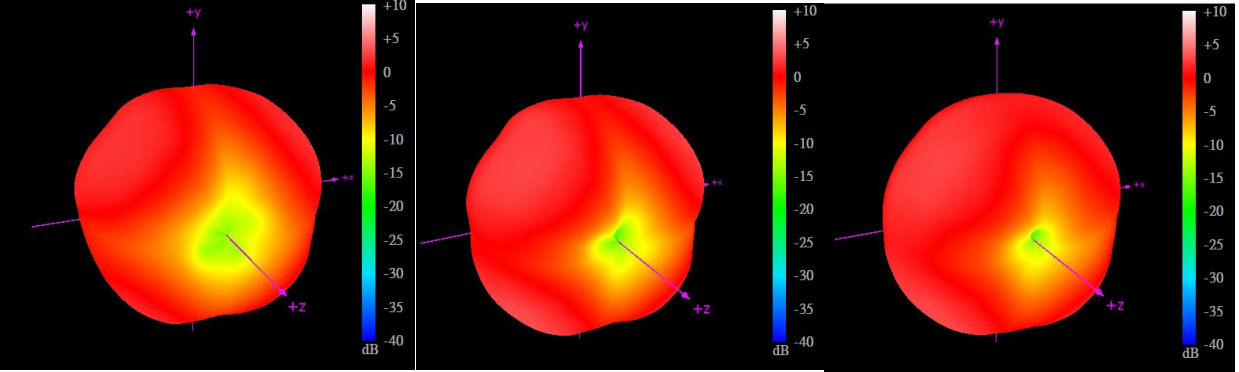

704MHz

751MHz

824MHz

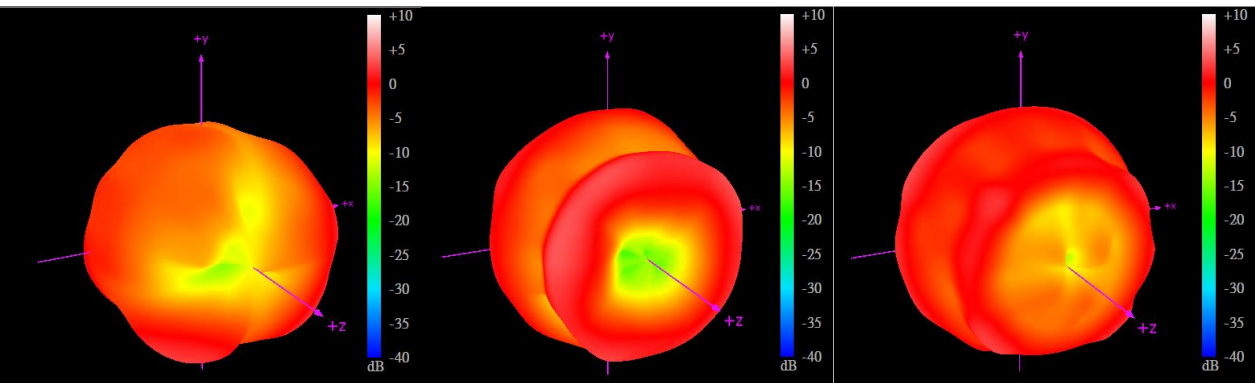

960MHz

1710MHz

1990MHz

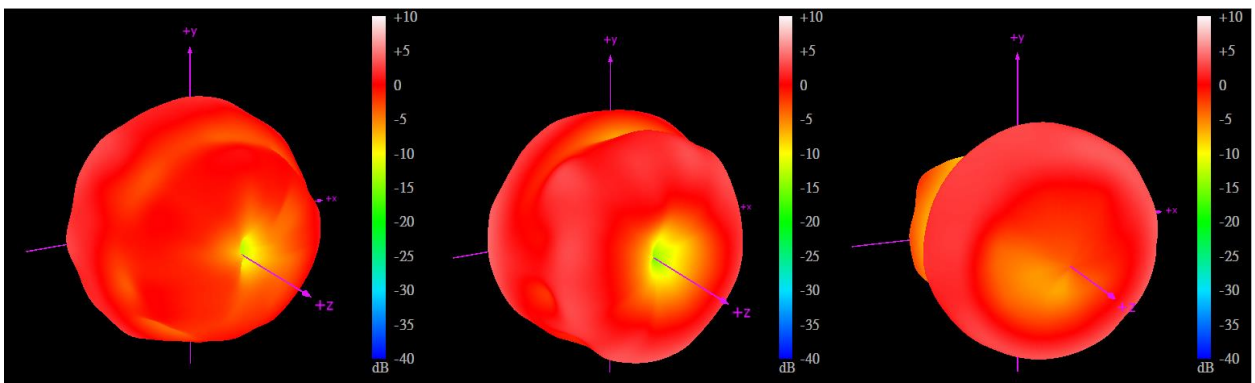

2170MHz

2500MHz

2690MHz

4. Mechanical Drawing (Unit:mm)

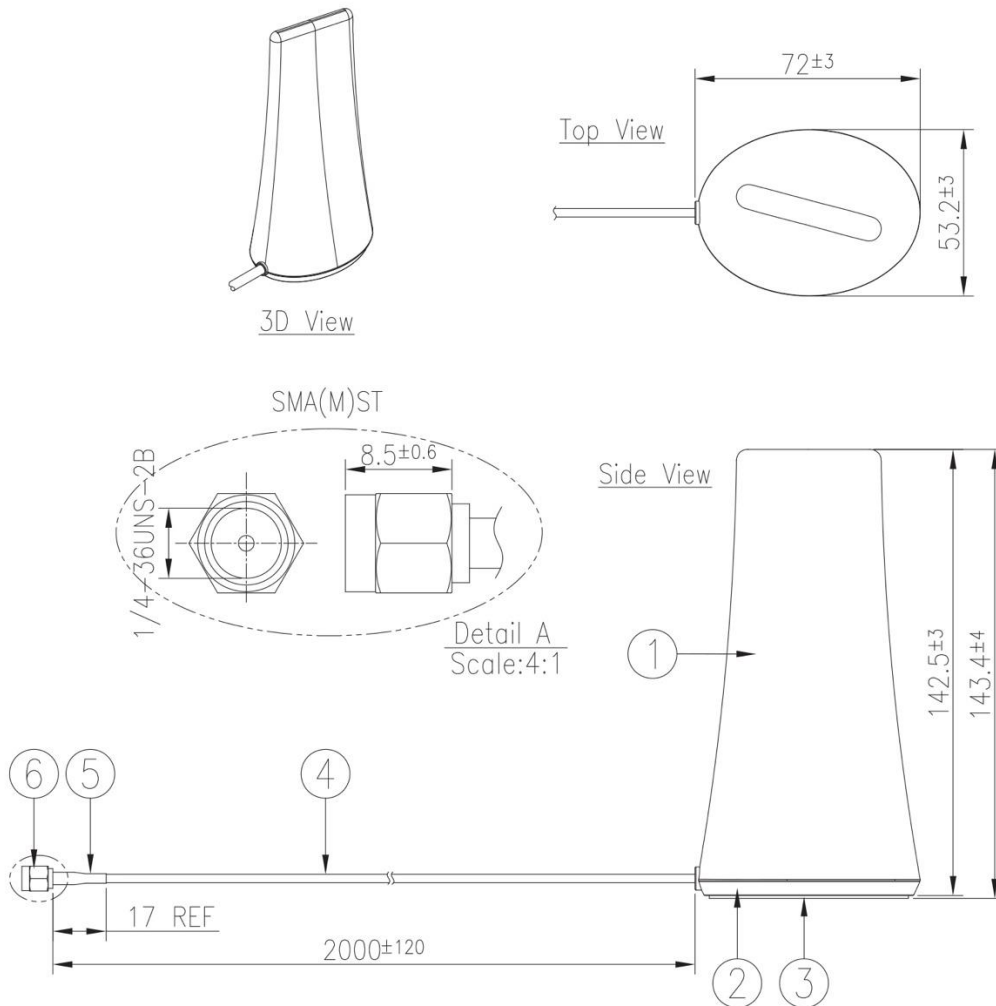

	Name	Material	Finish	QTY
1	Housing_Top	ASA	Black	1
2	Housing_Bottom	ASA	Black	1
3	3M Double Sided Adhesive(Black Foam)	3M467+CR4305	Brown Liner	1
4	RG174 Coaxial Cable	PVC	Black	1
5	Heat Shrink Tube	PE	Black	1
6	SMA(M)ST	Brass	Au Plated	1

5. Packaging

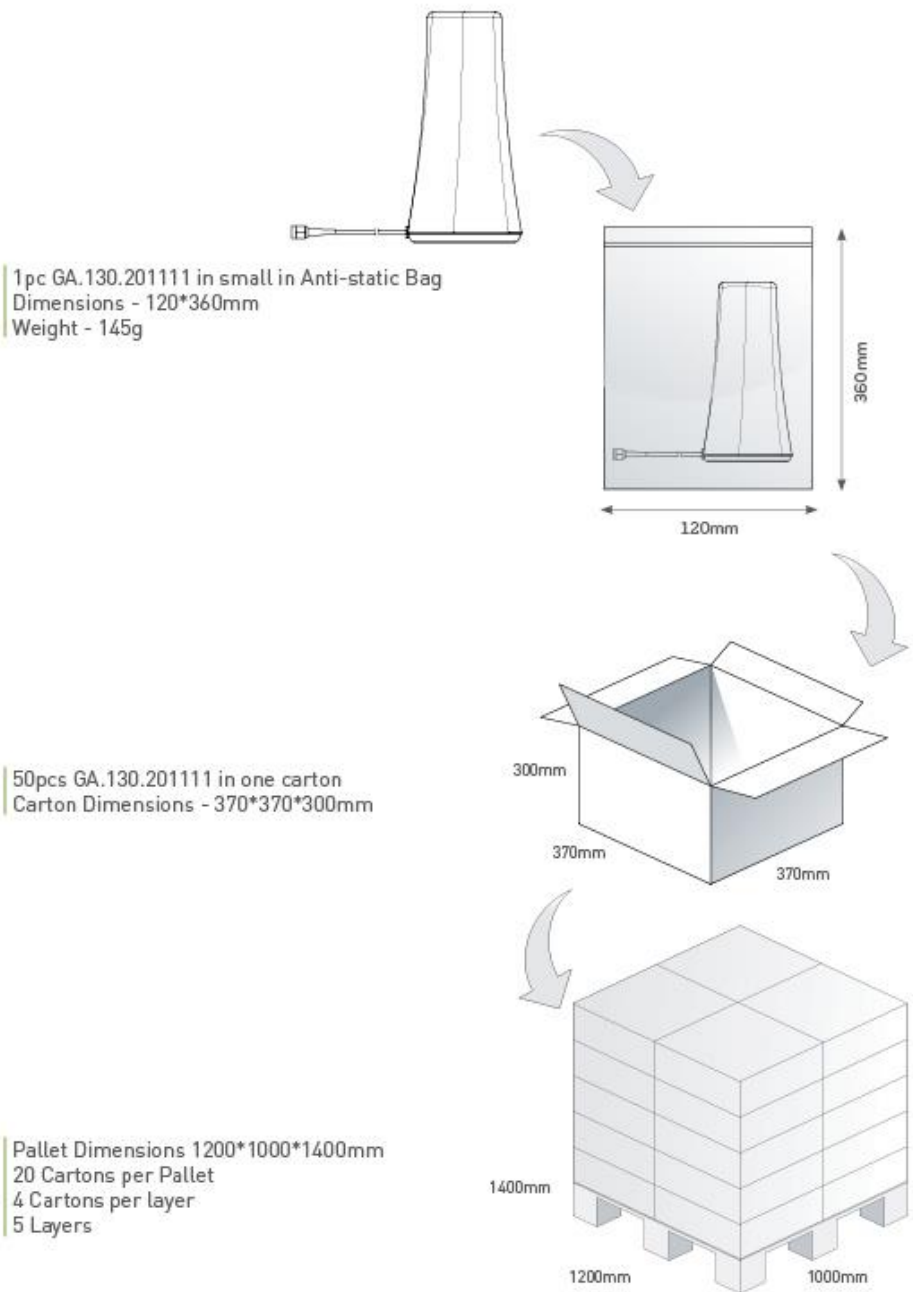

1pc GA.130.201111 in small in Anti-static Bag
Dimensions - 120*360mm
Weight - 145g

50pcs GA.130.201111 in one carton
Carton Dimensions - 370*370*300mm

Pallet Dimensions 1200*1000*1400mm
20 Cartons per Pallet
4 Cartons per layer
5 Layers

6. Application Note

Antenna performance with different cable lengths and mounting environments is shown below.

6.1 Return Loss

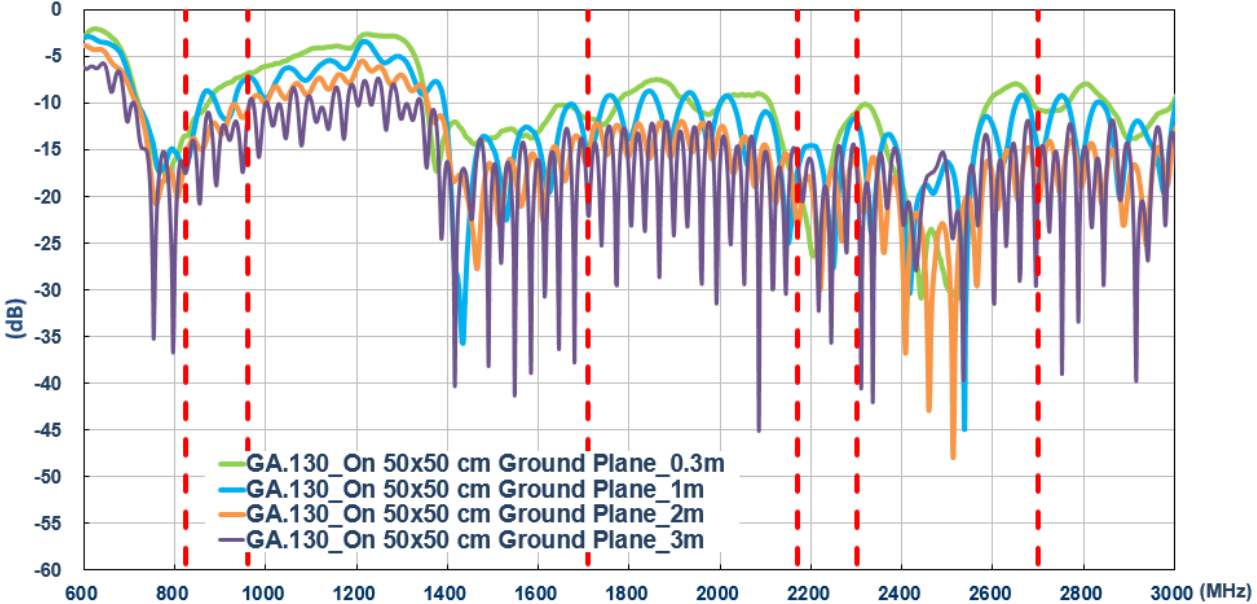
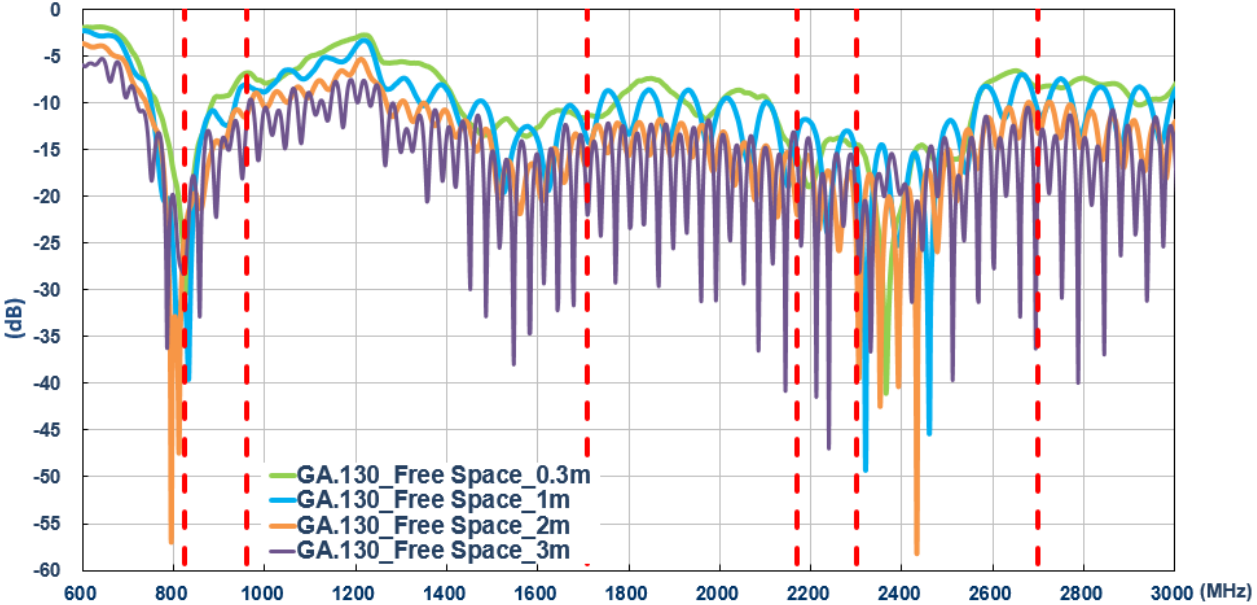

6.2 Efficiency

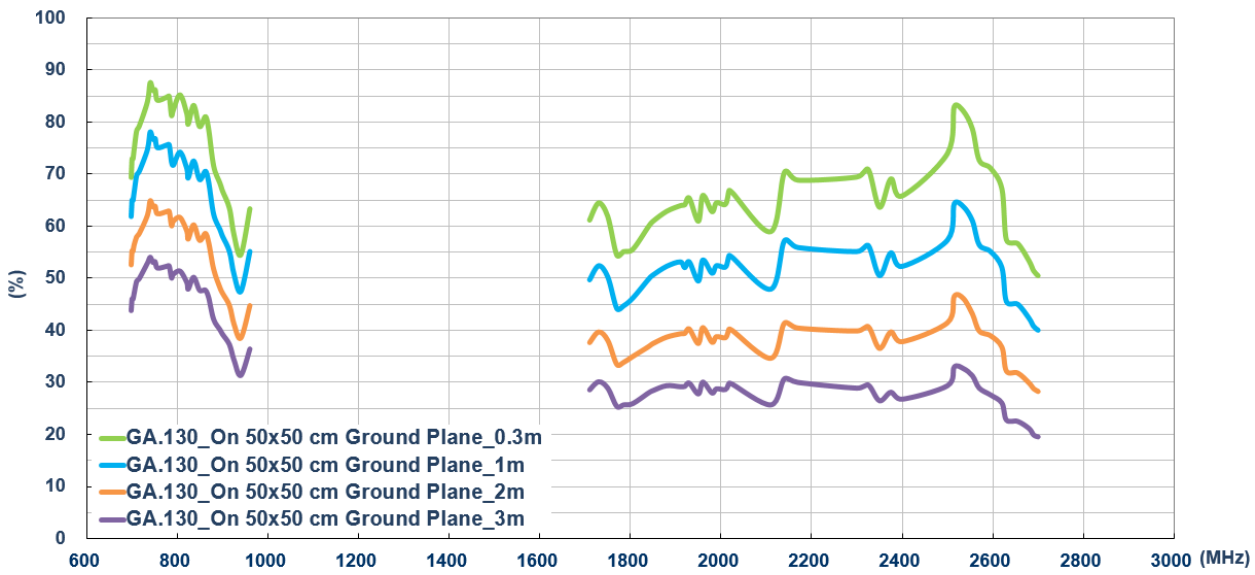
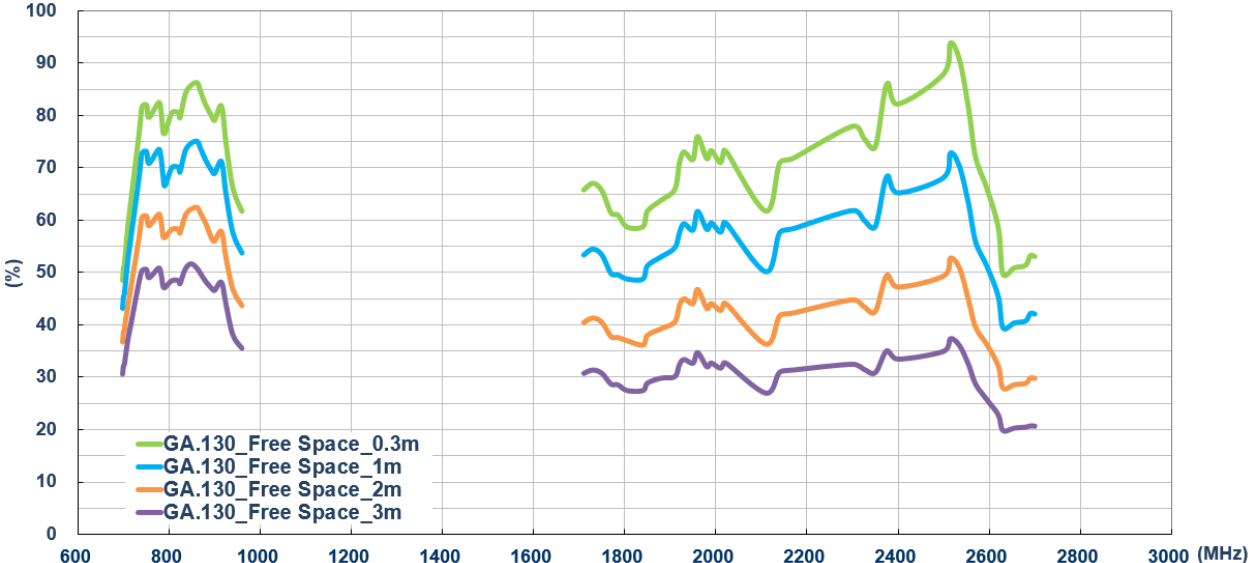

6.3 Average Gain

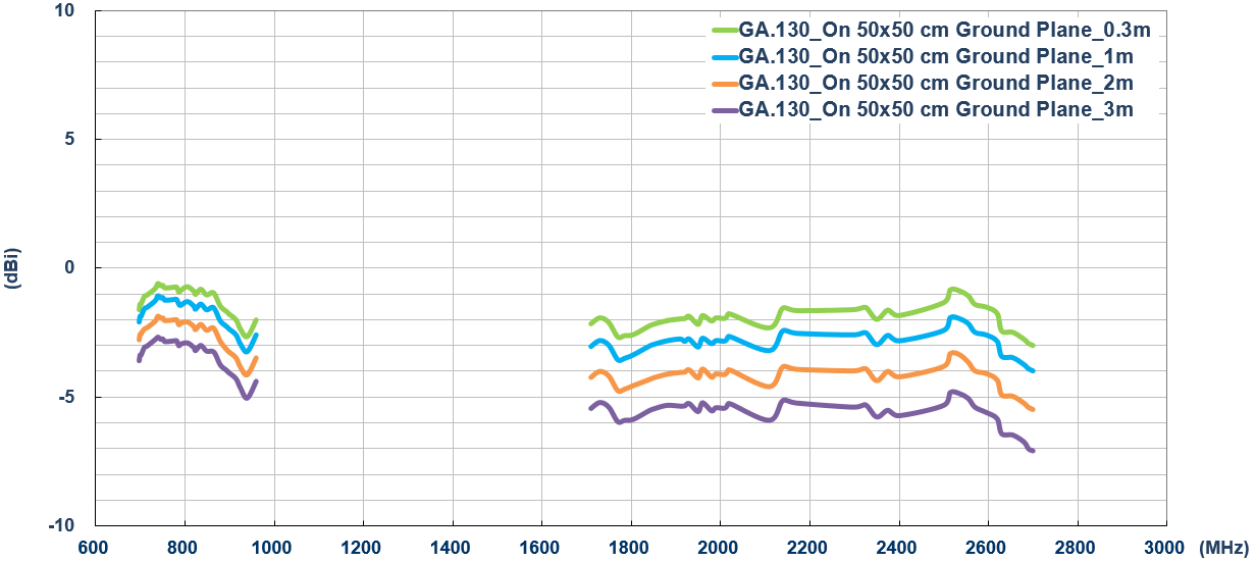
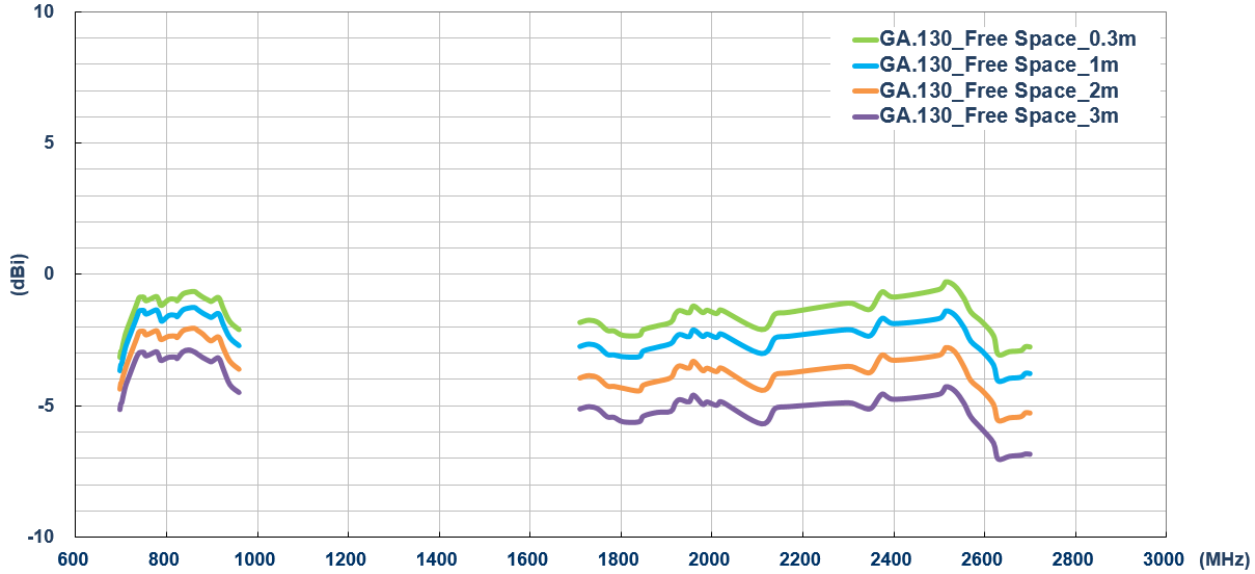

6.4 Peak Gain

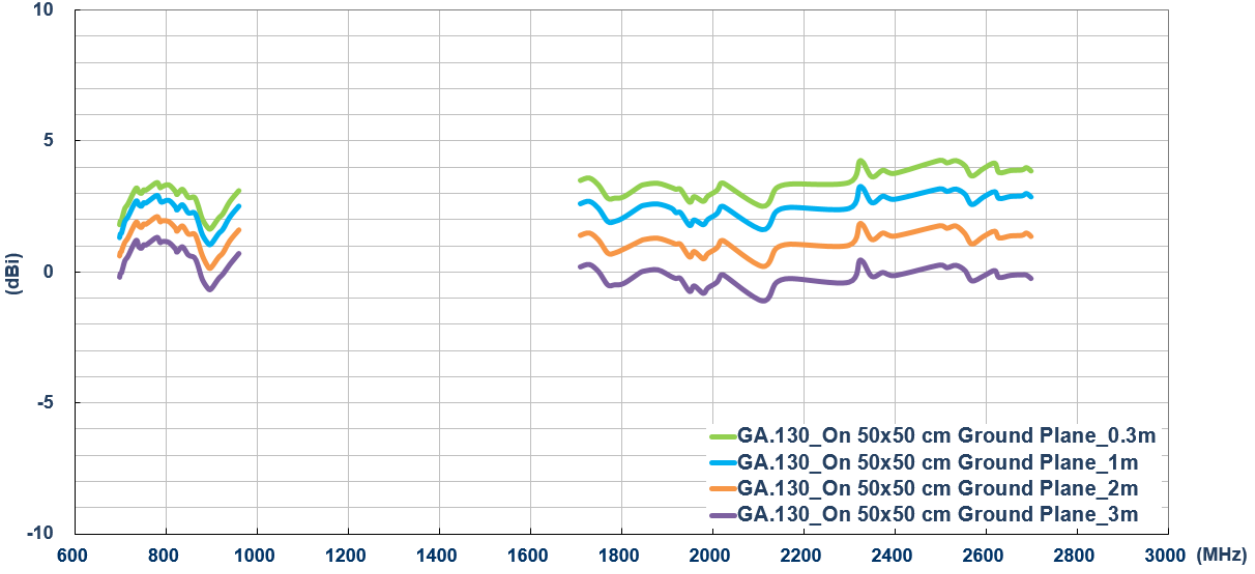
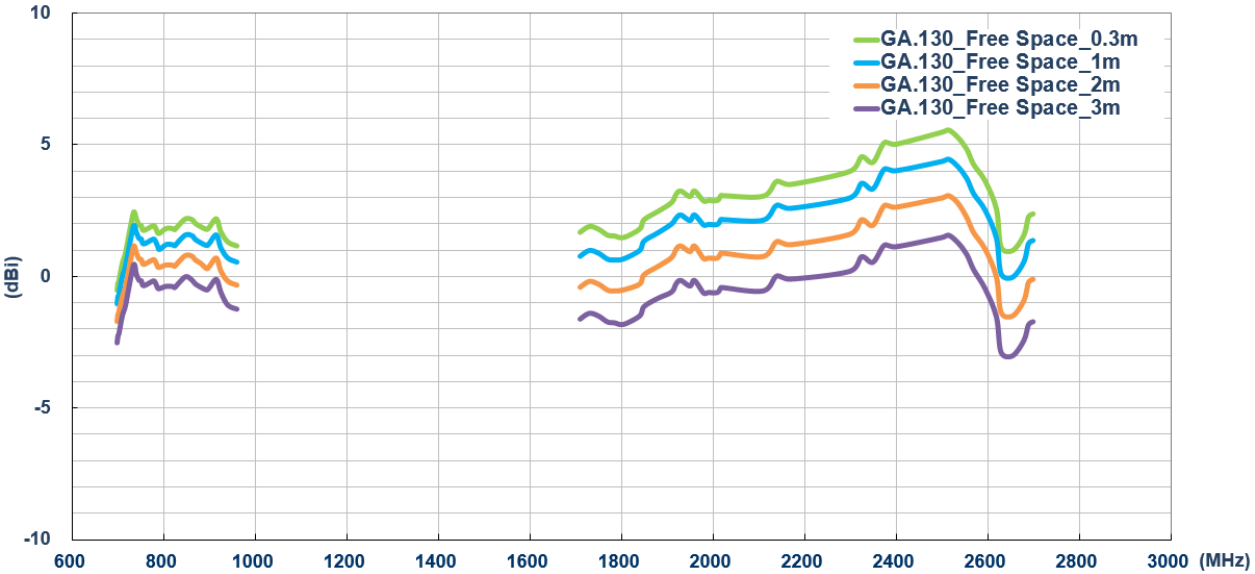

Taoglas makes no warranties based on the accuracy or completeness of the contents of this document and reserves the right to make changes to specifications and product descriptions at any time without notice. Taoglas reserves all rights to this document and the information contained herein.

Reproduction, use or disclosure to third parties without express permission is strictly prohibited.

© Taoglas