

Series 260V and 385V

Van Stone[†] Thermowells for 1/4" and 3/8" Diameter Elements



Application:

260V series fits standard length 1/4" diameter elements.
385V series fits standard length 3/8" diameter elements.

Connection Size:

Standard wells fit 1" lap joint flanges. Other sizes also available. Prices below are for 1" Van Stone Wells. Consult factory for prices on other sizes.

Materials:

Carbon Steel (C-1018), A.I.S.I. 304, A.I.S.I. 316 and Monel[®] are standard. Other materials are available.

Backing Flange:

When desired, a carbon steel lap joint flange can be supplied with these wells. When ordering, specify flange pressure.



Shown smaller than actual size.

Series 260V and 385V

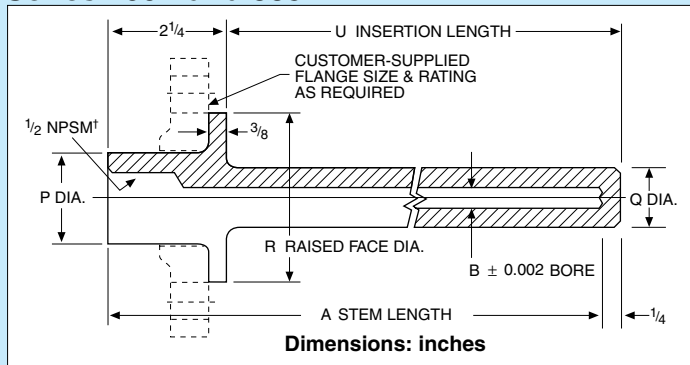

Metric Models Available! See omega.com

† NPSM internal pipe thread will accept both NPT and NPS male threads.

To Order Visit omega.com/series_260V_385V

Model Number	Stem Length A	Insertion Length U	Shank Diameter Q	Bore Diameter B
1-260V-U2-(*)	4	2	3/4	0.260
1-260V-U4-(*)	6	4	3/4	0.260
1-260V-U7-(*)	9	7	3/4	0.260
1-260V-U10-(*)	12	10	3/4	0.260
1-260V-U13-(*)	15	13	3/4	0.260
1-260V-U16-(*)	18	16	3/4	0.260
1-260V-U22-(*)	24	22	3/4	0.260
1-385V-U2-(*)	4	2	7/8	0.385
1-385V-U4-(*)	6	4	7/8	0.385
1-385V-U7-(*)	9	7	7/8	0.385
1-385V-U10-(*)	12	10	7/8	0.385
1-385V-U13-(*)	15	13	7/8	0.385
1-385V-U16-(*)	18	16	7/8	0.385
1-385V-U22-(*)	24	22	7/8	0.385

* Specify material type "304SS" for 304 stainless steel or "316SS" for 316 stainless steel.

Ordering Example: 1-260V-U10-316SS, 316SS Van Stone thermowell with 1" pipe OD, 0.260" ID, 12" stem length, and a 10" insertion length.

For Assistance in Choosing Head and Well Assemblies, See guide at omega.com. These wells are compatible with OMEGA[®] NB1, NB2 (page B-8); PR-12, PR-14, and NPT-style probes, as well as DialTemp[™] Thermometers.

† A Van Stone thermowell is an internal type flange thermowell that withstands high pressure within a chamber and will prevent the thermowell from "blowing" out. This type of connection requires access into the existing process components.

Other Dimensions (inch)

Pipe Size Nominal	Actual Dia. P	Raised Face Dia. R
1	1.315	2
1 1/2	1.900	

Maximum Fluid Velocity—feet per second

See Introduction to Thermowells, Section on Velocity at omega.com

Well Type	Material	Insertion Length – "U"						
		2	4	7	10	13	16	22
260V and 260F	Carbon Steel	404 (129)	184 (71.2)	67.0 (42.7)	34.0	20.6	13.7	7.4
	A.I.S.I. 304 & 316	430 (179)	192 (99.3)	69.7 (59.6)	35.4	21.5	14.3	7.7
	Monel	350 (143)	168 (79.8)	61 (47.7)	31.0	18.8	12.5	6.7
385V and 385F	Carbon Steel	410 (152)	248 (84.3)	91.3 (50.6)	45.7	27.6	18.5	10.0
	A.I.S.I. 304 & 316	444 (211)	258 (117)	95.2 (70.3)	47.6	28.8	19.3	10.4
	Monel	338 (168)	226 (93.3)	83.3 (56.0)	41.6	25.2	16.9	9.1

Where single values appear in the velocity tables, these may be considered safe for water, steam, air or gas. In the shorter insertion lengths, consideration is given to the velocity pressure effect of water flowing at higher velocities. The values in parentheses, therefore, represent safe values for water flow, while the unbracketed values may be used for steam, air, gas and similar density fluids.