

**Valve Manifolds Type 44 VTSA,
Type 45 VTSA-F**

Valve Manifolds Type 44 VTSA, Type 45 VTSA-F – Metric Series

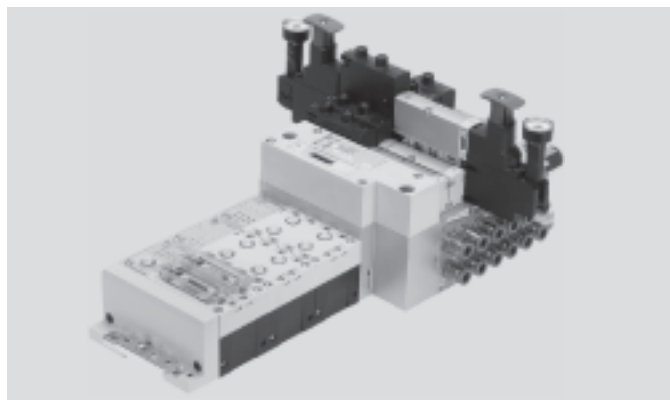

- Modular multi-functional valve manifold for up to 32 valves:
 - Type 44 VTSA, ISO 15407-2/ISO 5599-2
 - Type 45 VTSA-F with optimized flow
- Different valve sizes on one valve manifold:
 - 18 mm (ISO 02)
 - 26 mm (ISO 01)
 - 42 mm (ISO 1), type 44 VTSA only
- Flow rate: up to 1,500 l/min
- Design suitable for electrical peripherals CPX

Product Range Overview														
Electrical connection	Valve types													
	5/2-way valve, single solenoid with pneumatic spring return	5/2-way valve, single solenoid with spring return	5/2-way valve, double solenoid	5/2-way valve, double solenoid dominant switching	2x 3/2-way valve, normally open	2x 3/2-way valve, normally closed	2x 3/2-way valve: 1x normally open, 1x normally closed	5/3-way valve, mid-position pressurised	5/3-way valve, mid-position closed	5/3-way valve, mid-position exhausted	2x 3/2-way valve, normally open, reverse operation	2x 3/2-way valve, normally closed, reverse operation	2x 3/2-way valve: 1x normally open, 1x normally closed, reverse operation	Blanking plate for vacant position
	M	O	J	D	N	K	H	B	G	F	P	Q	R	L
Electrical multi-pin plug connection, CageClamp	■	■	■	■	■	■	■	■	■	■	■	■	■	■
Electrical multi-pin plug connection, Sub-D (37-pin)	■	■	■	■	■	■	■	■	■	■	■	■	■	■
Fieldbus connection/control block	■	■	■	■	■	■	■	■	■	■	■	■	■	■

Features

Flexible

- Easy modification and expansion due to high degree of modularity. Fast connection of the subbases by means of four screws.
- Fully modular system allows the combination of 18 mm (Size 02), 26 mm (Size 01) and 42 mm (Size 1) valves on the same manifold without the need for any transition/adaptor plate.
- Change direction of working ports with easy-to-install angle plate.
- Fieldbus valve terminal suitable for CPX electrical peripherals.

Easily integrated

- Fieldbus nodes: Interbus, DeviceNet, Profibus DP, CANopen, CC-Link via CPX terminal

- Ethernet: Modbus/TCP, EtherNet/IP, TCP/IP via CPX terminal
- Full complement of CPX I/O modules
- Expandable up to 32 solenoid coils
- Integration of a wide range of function modules possible
- Supply plates permit a flexible air supply and variable pressure zones

Comprehensive

- High-performance valves in a sturdy metal housing
- Complete range of vertical sandwich components such as pressure regulators, flow control valve, individual pressure supply, shutoff plate (hot swap).
- Standard air qualities: 40 micron filtration grade. Can be used with lubricated or non-lubricated air, and inert gases.

- Manual override available, with momentary, locking, or hidden (non-accessible) options.

Installation and maintenance

- Ready-to-install unit, preassembled and tested
- Durable, low cost identification by label holder on the valve or label holder on the subbase.
- Secure wall mounting or DIN rail mounting
- Fast troubleshooting thanks to LEDs on the valves and diagnosis via fieldbus.
- Reliability of service thanks to valves that can be replaced easily and quickly.
- Easy fault identification using CPX-MMI handheld diagnostic unit.

Contents

Features and Benefits	→ 2
Overview	→ 3
Pneumatic Components	→ 17
Electrical Components	→ 35
Installation and Operation	→ 40
Technical Data	→ 44
Dimensional Drawings	
– Type 44 VTSA	→ 51
– Type 45 VTSA-F	→ 64
Ordering Data	
– Type 44 VTSA	→ 71
– Type 45 VTSA-F	→ 81
Accessories	→ 93

- www.festo.com/catalog/vtasa
- www.festo.com/catalog/vtasa-f

Features and Benefits

Valve Manifolds Type 44 VTSA, Type 45 VTSA-F – Metric Series

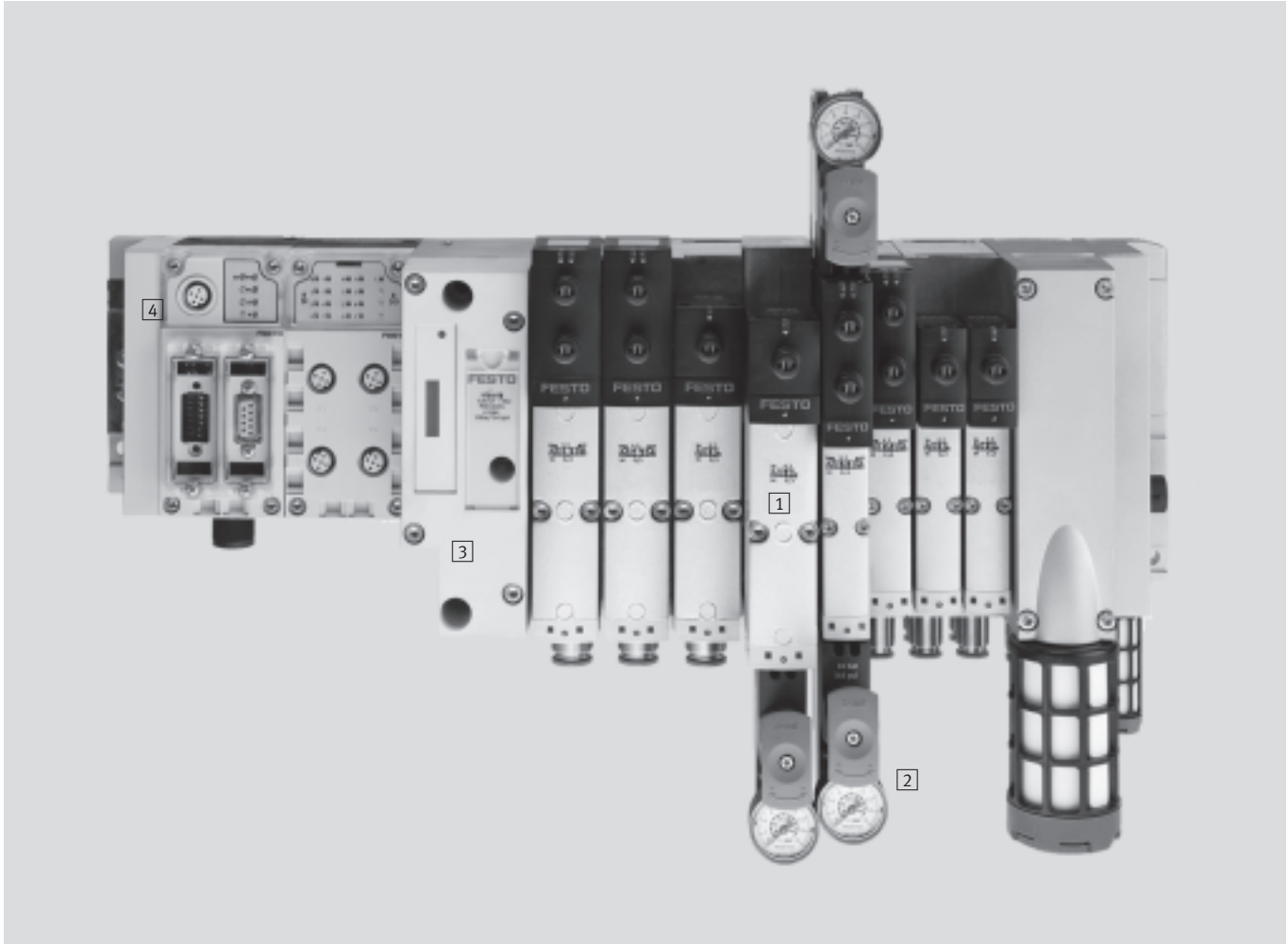

1 Combination of sizes

The flexible combination of different valve sizes on a single valve terminal (18 mm, 26 mm and 42 mm) allows adaptation to different flow requirements. For greater freedom and optimized applications.

2 Operating efficiency

Adjustment of regulators without tools. And with the standardized operating direction from above for regulators and valves, this terminal offers the solution to just about every requirement in terms of functionality.

3 Connection to CPX

What about fieldbus and modular I/Os? Connection to the modern CPX terminal is an added benefit. This level of freedom, modularity, and versatility is unmatched in any valve manifold solution.

4 Decentralized intelligence

The CPX-MMI-1 hand-held device explains errors in plain text and helps expedite troubleshooting, reducing downtimes. Remote maintenance via Ethernet/Internet eliminates the need for servicing at night and over long distances, which can often be very expensive. The on-site intelligence permits CMS (Condition Monitoring Systems) for each valve and statistical error logging with history and timestamp.

A higher degree of modularity

- Valve manifold type 44 VTSA complies to ISO 15407-2 in width 18 and 26 mm and with ISO 5599-2 in width 42 mm. The VTSA terminal can be used for all applications
- Simple connection of pneumatic and electrical components
- Flow rate up to 1,500 l/min
- 5/2-way, 2x 3/2-way and 5/3-way valve functions
- Voltage options: 24 V DC or 110 V AC
- IP65 rated
- Modular and flexible
- Easy diagnostics and maintenance
- Reliable and durable
- Competitive pricing

Overview – Key Features

Valve Manifolds Type 44 VTSA, Type 45 VTSA-F – Metric Series

Valve Manifold

Reduced downtimes:
LED diagnosis on the spot

Width 18 mm, 26 mm and
42 mm can be combined on a
single manifold without adapter

Pneumatic interface to CPX

Straightforward electrical
connections

- Fieldbus connection via CPX
- Multi-pin plug connection with pre-assembled cable or manifold strip (Cage Clamp)
- Control block via CPX
- Individual connection

CPX diagnostic interface for
handheld devices (channel-oriented
diagnosis down to the individual valve)

Quick mounting:
Direct mounting using screws or DIN H-rail

Secure:
Valves, outputs and logic voltage
can be switched off separately

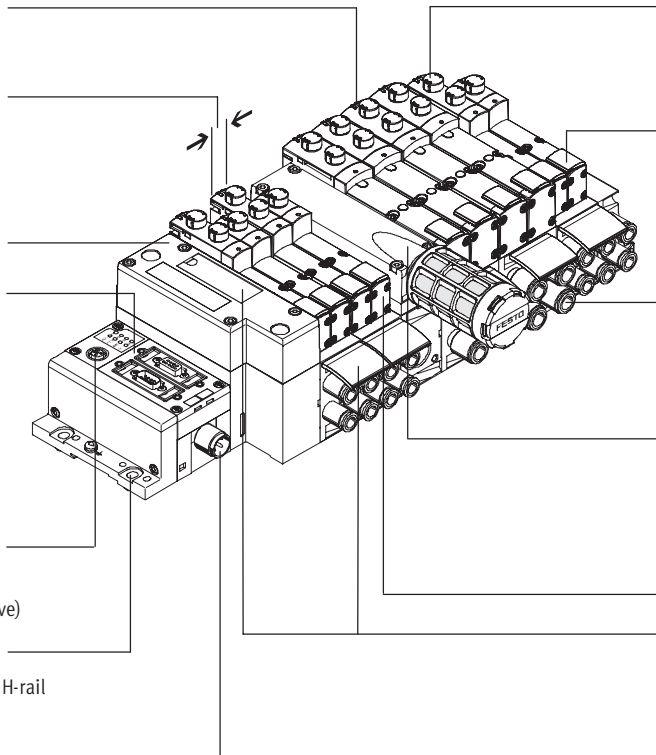

Reliable operation:
Manual override: pushing/detented
or with cover

Flexible:

- 32 valve positions/32 solenoid coils
- One valve series for a wide range of flow rates

Functional:
Large ports, flow-optimized ducts,
robust metal thread or pre-assembled
QS connections

Modular:
Supply plates facilitate the creation of
multiple pressure zones as well as
numerous additional exhaust and supply
ports

Comprehensive valve functions

Practical:
Large inscription labels

Valve Functions

- 5/2-way valve
 - Single solenoid valve, pneumatic/spring return
 - Double solenoid valve
 - Double solenoid valve with dominant signal
- 2x 3/2-way valve, single solenoid
 - Normally open
 - Normally open, reversible
 - Normally closed
 - Normally closed, reversible
 - 1x normally open, 1x normally closed
 - 1x normally open, 1x normally closed, reversible
- 5/3-way valve
 - Mid-position pressurized
 - Mid-position closed
 - Mid-position exhausted

Special Features

Multi-pin plug manifold

- Max. 32 valve positions/
max. 32 solenoid coils
- Parallel modular valve linking
- Any compressed air supply
- Any number of pressure zones

Fieldbus manifold/control block

- Max. 32 valve positions/
max. 32 solenoid coils
- Any compressed air supply
- Any number of pressure zones

Individual valve

- Electrical connection via standardized 4-pin M12 plug or via 4-pin clamped manifold connection for configuration by the user
- Available with internal/external pilot air supply

Combinable

- Width 18 mm:
valve flow rate up to 700 l/min
- Width 26 mm:
valve flow rate up to 1,400 l/min
- Width 42 mm:
valve flow rate up to 1,500 l/min
- Width 42 mm, 26 mm and 18 mm can be combined on a single valve manifold

Overview – Electrical Connections

Valve Manifolds Type 44 VTSA, Type 45 VTSA-F – Metric Series

Individual Connection

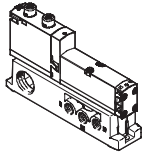
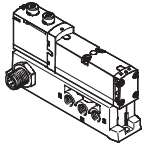

Valves on individual subbases can be used for actuators further away from the valve manifold.

The electrical connection is established using a standard 4-pin M12 plug 24 V DC (EN 61076-2-101)

or it can be configured by the user with a 4-pin clamped manifold connection 24 V DC or 110 V AC.

Manifold Connection

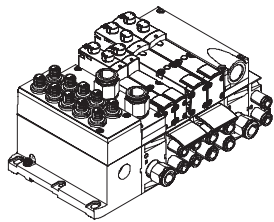

An individual connecting cable carries the control signal between the controller and the valve manifold.

The valve manifolds can be fitted with max. 20 valves and max. 20 solenoid coils.

The electrical connection is established via a 5-pin M12 plug 24 V DC

Multi-pin Plug Connection

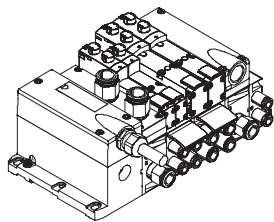

Control signals from the controller to the valve manifold are transmitted via a pre-assembled multi-core cable or a self-assembled multi-pin plug connection (Cage Clamp), which substantially reduces installation time.

The valve manifolds can be fitted with max. 32 valves and max. 32 solenoid coils.

Variants

- Multi-pin plug connection with manifold strip (Cage Clamp) 24 V DC or 110 V AC
- Pre-assembled connecting cable 24 V DC
- Sub-D plug connector for fitting by users, 37-pin

Overview – Electrical Connections

Valve Manifolds Type 44 VTSA, Type 45 VTSA-F – Metric Series

Fieldbus Connection via the CPX System

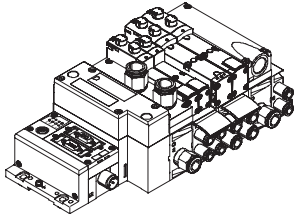

An integrated fieldbus node manages the communication connection to a higher-order PLC. This enables a space-saving pneumatic and electronic solution.

Valve manifolds with fieldbus interfaces can be configured with up to 16 manifold subbases. With 2 solenoid coils per connection, up to 32 solenoid coils can thus be actuated.

Variants

- Profibus-DP
- Interbus
- DeviceNet
- CANopen
- CC-Link
- Ethernet/IP
- CPX manifold

➔ www.festo.com/catalog/cpx

Control Block Connection via the CPX System

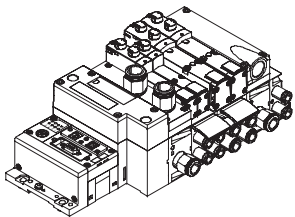

Controllers integrated in the Festo valve manifolds permit the construction of stand-alone control units to IP65, without control cabinets.

Using the slave operation mode, these valve manifolds can be used for intelligent pre-processing and are therefore ideal modules for designing decentralised intelligence.

In the master operation mode, manifold groups can be designed with many options and functions, which can autonomously control a medium-sized machine/system.

- CPX manifold

➔ www.festo.com/catalog/cpx

CP String Extension

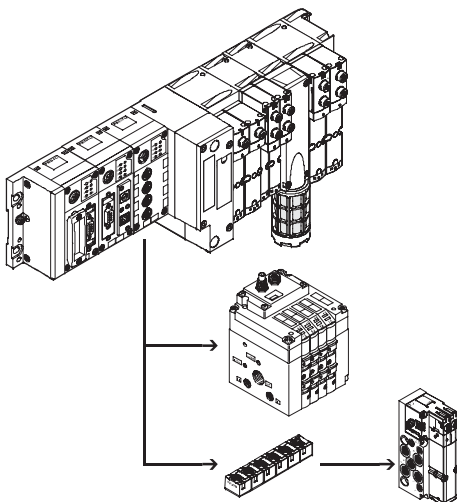

The optional string extension allows additional valve manifolds and I/O modules to be connected to the fieldbus node of the CPX manifold. Different input and output modules as well as CPV-SC, CPV and CPA valve manifolds can be connected. The maximum length of the CP string extension is 10 metres, which means that the extension modules can be mounted directly on site. All of the required electrical signals are transmitted via the CP cable, which in turn means that no further installation is needed on the extension module.

The CP string interface offers:

- 32 input signals
- 32 output signals for output modules 24 V DC or solenoid coils
- Logic and sensor supply for the input modules
- Load voltage supply for the valve manifolds
- Logic supply for the output modules

➔ www.festo.com/catalog/cpi

Overview – Pneumatic Components

Valve Manifolds Type 44 VTSA, Type 45 VTSA-F – Metric Series

Modular Pneumatic Components

The modular design of the VTSA/VTSA-F facilitates maximum flexibility right from the planning stage and offers maximum ease of service in operation.

The system consists of manifold subbases and valves. The manifold subbases are screwed together and thus form the support system for the valves.

Inside, the manifold subbases contain the connection ducts for supplying compressed air to and venting from the valve manifold as well as the working ports for the pneumatic cylinders from each valve.

Each manifold subbase is connected to the next using four screws. Individual manifold sections can be isolated and further blocks inserted by loosening these screws. This ensures that the valve manifold can be rapidly and reliably expanded.

Modularity in the basic system

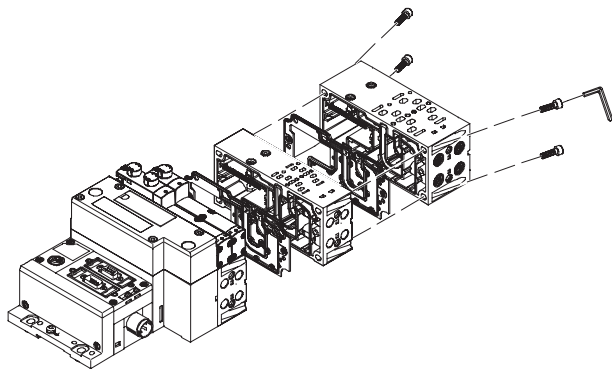

Modularity in the valves

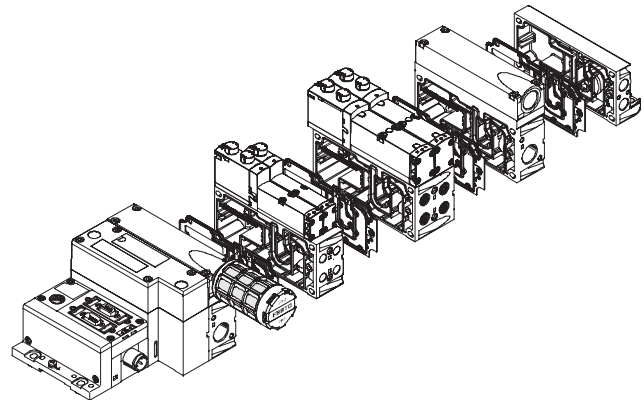

Modularity in the vertical stacking

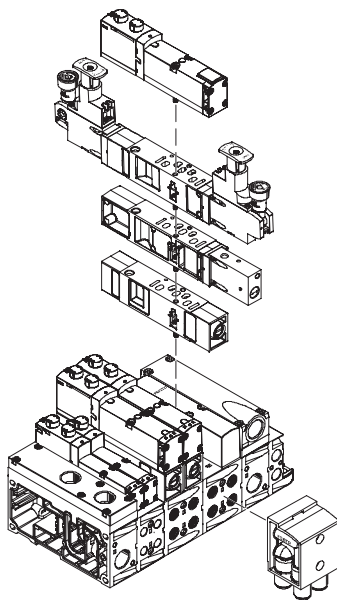

Overview – Electrical Components

Valve Manifolds Type 44 VTSA, Type 45 VTSA-F – Metric Series

Modular Electrical Peripherals

The manner in which the valves are actuated differs according to whether you are using a multi-pin manifold or fieldbus manifold.

The VTSA/-VTSA-F with CPX interface is based on the internal bus system of the CPX and uses this communication system for all solenoid coils and a range of electrical input and output functions.

Parallel linking facilitates the following:

- Transmission of switching information
- High valve density
- Compact design
- Position-based diagnosis
- Separate voltage supply for valves
- Flexible conversion without address shifting
- Transmission of status, parameter and diagnostic data

VTSA with electrical peripherals CPX

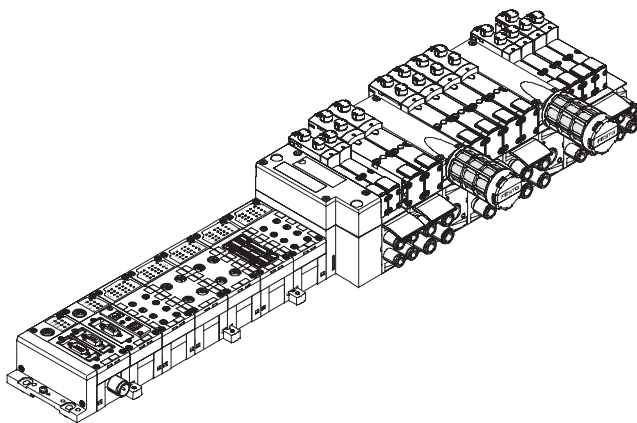

Modularity with electrical peripherals CPX

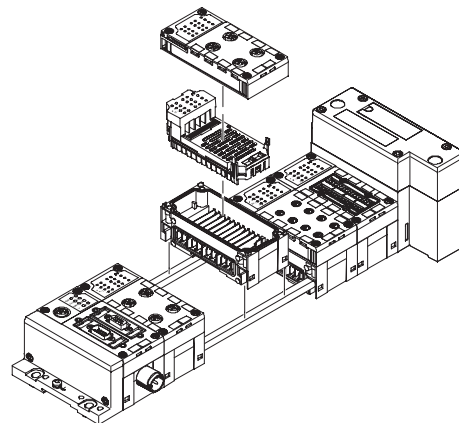

Overview – Multi-pin Connection

Valve Manifolds Type 44 VTSA, Type 45 VTSA-F – Metric Series

Valve Manifold with Multi-pin Plug Connection

Order code:

- 44E for the electrical components
 - 44P for the pneumatic components
 - 45P... for the pneumatic components.
- High flow rate with optimized manifold subbases.

Valve manifolds with multi-pin plug connection can be expanded with up to 32 valves with max. 32 solenoid coils.

The manifold subbases width 18 and 26 mm are prepared for:

- 2 single solenoid valves
- 2 double solenoid valves

The manifold subbases width 42 mm are prepared for:

- 1 single solenoid valve
- 1 double solenoid valve depending on the size.

- Double solenoid valve positions can be equipped with any valve or a blanking plate.
- Single solenoid valve positions can only be equipped with single solenoid valves or a blanking plate.

The following multi-pin plug connections to IP65 are available:

- 37-pin Sub-D connection (24 V DC):
The connecting cable can be ordered in lengths of 2.5 m, 5 m and 10 m for max. 8, 22 or 32 solenoid coils.
- Manifold strip (24 V DC or 110 V AC)

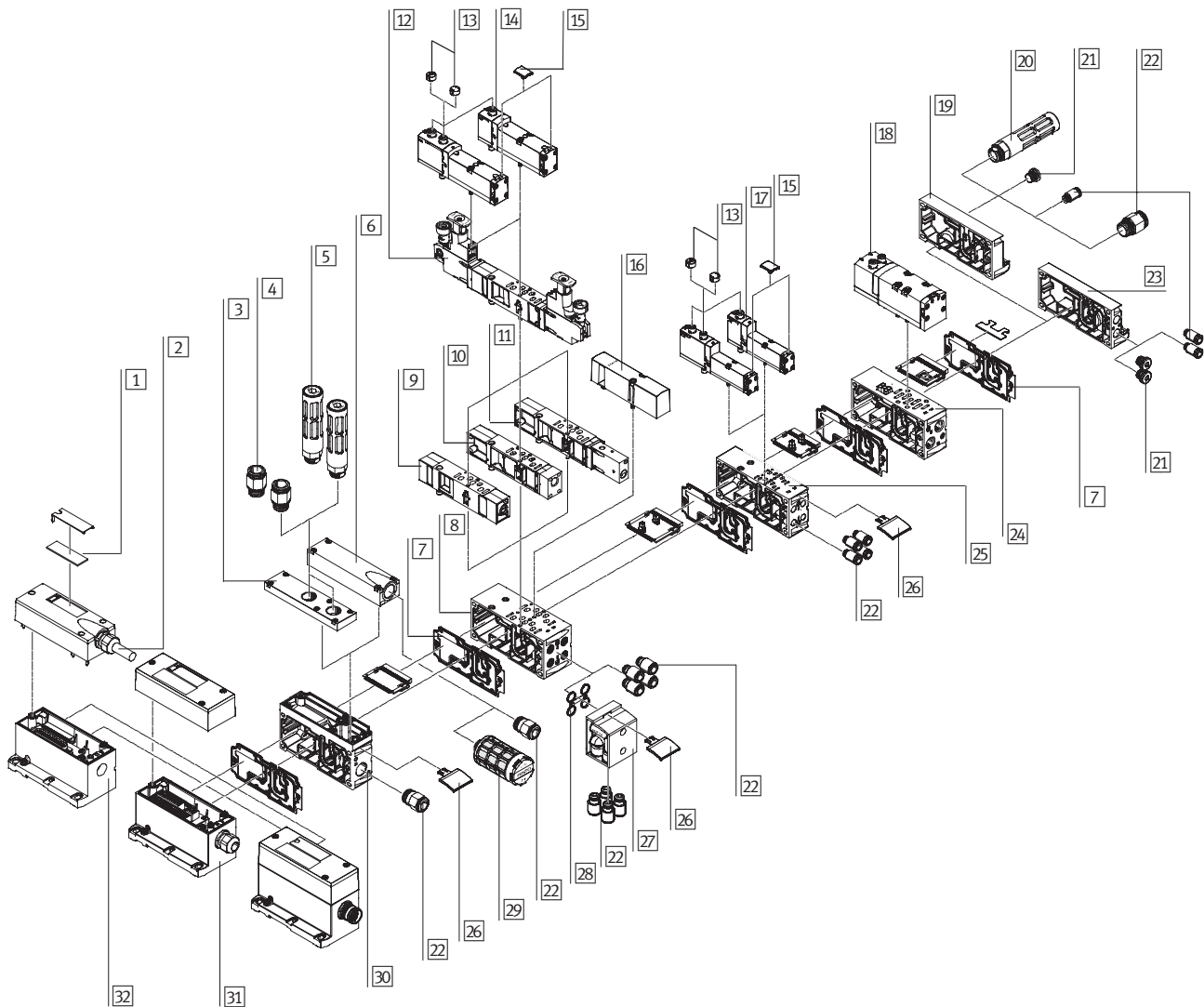

Overview – Multi-pin Connection

Valve Manifolds Type 44 VTSA, Type 45 VTSA-F – Metric Series

Valve Manifold with Multi-pin Plug Connection			
	Brief description	→ Page	
1	Inscription labels	Large, for multi-pin plug connection	–
2	Multi-core cable		98
3	Exhaust plate	Ports 3 and 5 separated	95
4	Fittings	For supply plate	99
5	Silencer	For supply plate	99
6	Exhaust port cover	For ducted exhaust air (ports 3 and 5 combined)	95
7	Duct separation/seal		95
8	Manifold subbase	For valves with a width of 26 mm	95
9	Flow control plate		97
10	Vertical supply plate		95
11	Vertical shut-off plate		97
12	Pressure regulator plate		96
13	Cover cap	For manual override, pushing, covered	99
14	Valve	Width 26 mm	91
15	Inscription label holder	For valve	99
16	Blanking plate	For unused valve position (vacant position)	99
17	Valve	Width 18 mm	91
18	Valve	Width 42 mm (type 44 only)	91
19	Right-hand end plate		93
20	Silencer	For end plate	99
21	Blanking plugs		100
22	Fittings		99
23	End plate with pilot air selector		93
24	Manifold subbase	For valves with a width of 42 mm (type 44 only)	93
25	Manifold subbase	For valves with a width of 18 mm	93
26	Inscription label holder	For supply plate, subbase, 90° connection plate	99
27	90° connection plate		95
28	Seals		95
29	Silencer		99
30	Supply plate		95
31	Multi-pin plug connection	Via manifold strip (CageClamp) 24 V DC or 110 V AC	97
32	Multi-pin plug connection	With multi-core cable 24 V DC	97

Note

The choice of silencer to be used depends on the type of vertical stacking of the valve positions to the left and the right of the supply plate.

Exhaust port cover [6] with plastic exhaust air silencer type U-1/2
– A pressure regulator plate

Exhaust port cover [6] with metal exhaust air silencer type U-1/2-B
– P pressure regulator plate
– B pressure regulator plate
– AB pressure regulator plate
– Vertical shut-off plate
– Vertical supply plate
– Flow control plate

Overview – Fieldbus Connection

Valve Manifolds Type 44 VTSA, Type 45 VTSA-F – Metric Series

Valve Manifold with Fieldbus Connection, Control Block (Electrical Peripherals CPX)

Order code:

- 50E... for the electrical peripherals
- 44P for the pneumatic components
- 45P... for the pneumatic components.
High flow rate with optimized manifold subbases.

Valve manifolds with fieldbus interface can be expanded with up to 32 valves with max. 32 solenoid coils. Each valve position can be fitted with any valve or a blanking plate.

The rules for CPX apply to the equipment that can be used in combination with the electrical peripherals CPX.

In general:

- Max. 10 electrical modules
- Digital inputs/outputs
- Analogue inputs/outputs
- Parameterisation of inputs and outputs
- Integrated feature-rich diagnostic system
- Preventive maintenance concepts

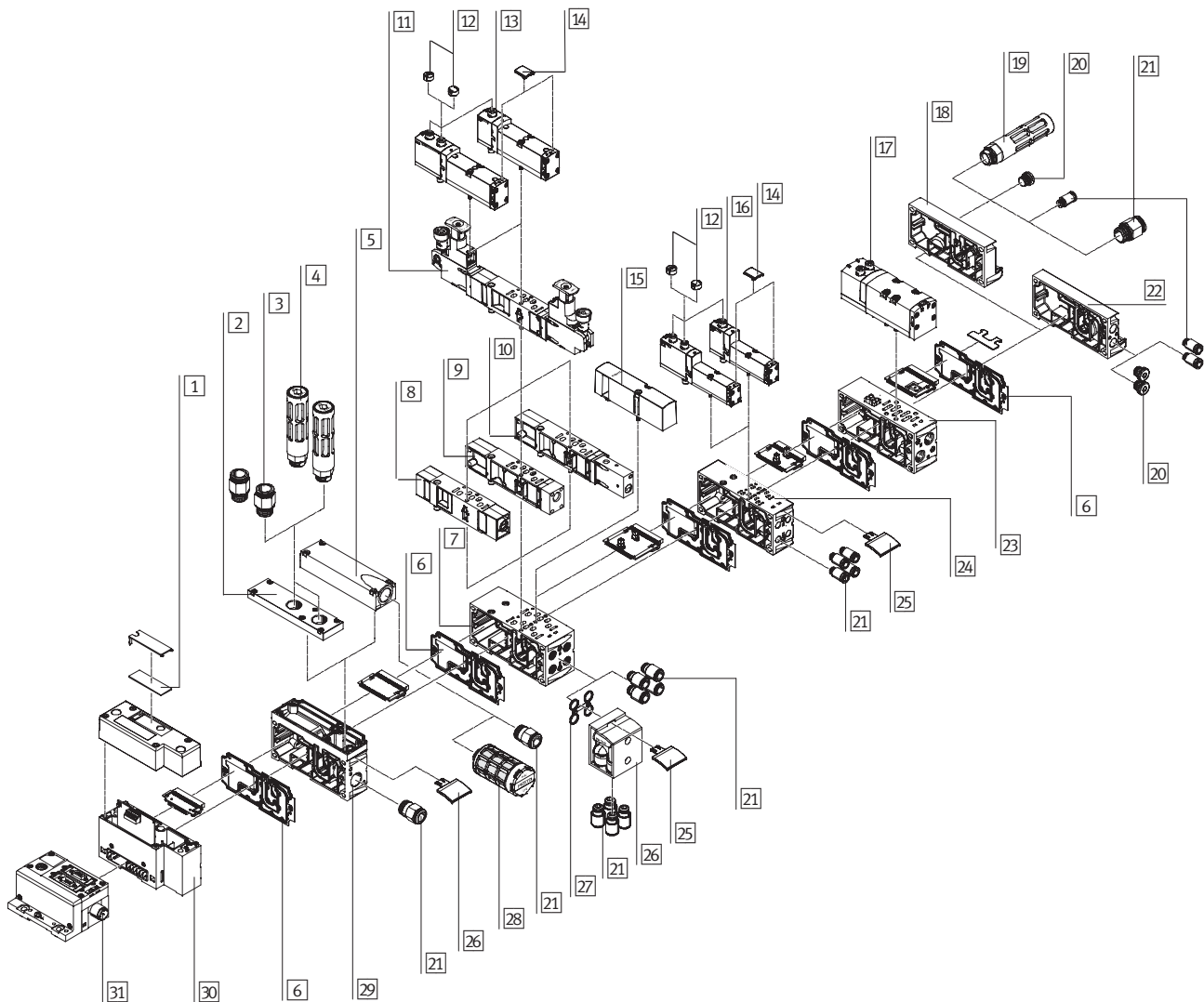

Overview – Fieldbus Connection

Valve Manifolds Type 44 VTSA, Type 45 VTSA-F – Metric Series

Valve Manifold with Fieldbus Connection, Control Block (Electrical Peripherals CPX)			
	Brief description	→ Page	
1	Inscription labels	Large, for pneumatic interface CPX	–
2	Exhaust plate	Ports 3 and 5 separated	95
3	Fittings	For supply plate	99
4	Silencer	For supply plate	99
5	Exhaust port cover	For ducted exhaust air (ports 3 and 5 combined)	95
6	Duct separation/seal		95
7	Manifold subbase	For valves with a width of 26 mm	93
8	Flow control plate		97
9	Vertical supply plate		95
10	Vertical shut-off plate		97
11	Pressure regulator plate		96
12	Cover cap	For manual override, pushing, covered	99
13	Valve	Width 26 mm	91
14	Inscription label holder	For valve	99
15	Blanking plate	For unused valve position (vacant position)	99
16	Valve	Width 18 mm	91
17	Valve	Width 42 mm (type 44 only)	91
18	Right-hand end plate		93
19	Silencer	For end plate	99
20	Blanking plugs		100
21	Fittings		99
22	End plate with pilot air selector		93
23	Manifold subbase	For valves with a width of 42 mm (type 44 only)	93
24	Manifold subbase	For valves with a width of 18 mm	93
25	Inscription label holder	For supply plate/subbase/90° connection plate	99
26	90° connection plate		95
27	Seals		95
28	Silencer		99
29	Supply plate		95
30	Pneumatic interface		97
31	Fieldbus interface		–

Note

The choice of silencer to be used depends on the type of vertical stacking of the valve positions to the left and the right of the supply plate.

Exhaust port cover [5] with plastic exhaust air silencer type U-1/2
– A pressure regulator plate

Exhaust port cover [5] with metal exhaust air silencer type U-1/2-B
– P pressure regulator plate
– B pressure regulator plate
– AB pressure regulator plate
– Vertical shut-off plate
– Vertical supply plate
– Flow control plate

Overview – Single Subbases

Valve Manifolds Type 44 VTSA, Type 45 VTSA-F – Metric Series

Individual Subbase

Order code:

- Using individual part numbers

Individual subbases can be equipped with any valve.

The electrical connection is established using a standard 4-pin M12 plug (EN 61076-2-101) or it can be

configured by the user with a 4-pin clamped manifold connection/open cable end.

Width 18 mm with M12 plug

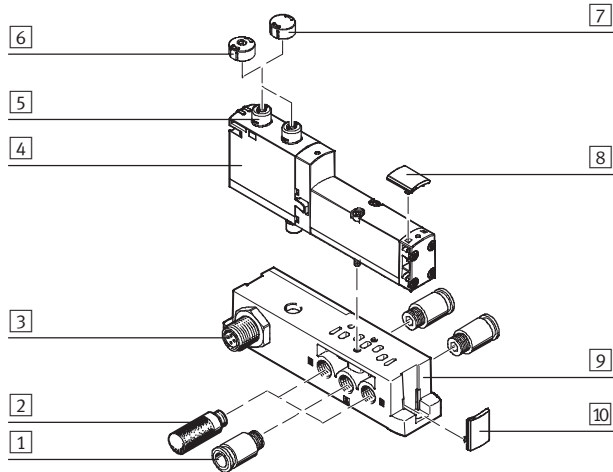

Width 26 mm with M12 plug

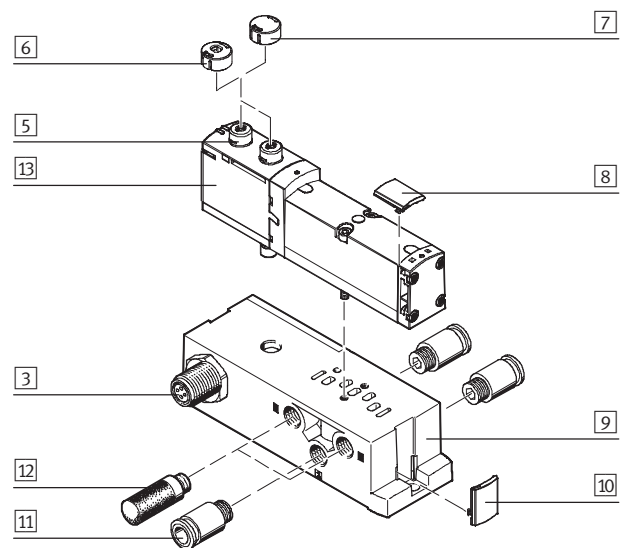

	Brief description	→ Page	
1	Fitting	G $\frac{1}{8}$ for supply/exhaust ports (1, 3, 5) and working ports (2, 4)	99
2	Silencer	G $\frac{1}{8}$ for supply/exhaust ports (1, 3, 5)	99
3	Electrical connection M12 ¹⁾	4-pin	–
4	VSVA valve	Width 18 mm	91
5	Manual override	Non-detenting/detenting, per solenoid coil	–
6	Cover cap	For manual override, pushing	99
7	Cover cap	For manual override, covered	99
8	Inscription label holder	For valves	99
9	Individual subbase	For valve VSVA	94
10	Inscription label holder	For manifold blocks	99
11	Fitting	G $\frac{1}{4}$ for supply/exhaust ports (1, 3, 5) and working ports (2, 4)	99
12	Silencer	G $\frac{1}{4}$ for supply/exhaust ports (1, 3, 5)	99
13	VSVA valve	Width 26 mm	91

1) Only with 24 VDC

Overview – Single Subbases

Valve Manifolds Type 44 VTSA, Type 45 VTSA-F – Metric Series

Individual Subbase
 Width 18 mm with clamped manifold connection Width 26 mm with clamped manifold connection

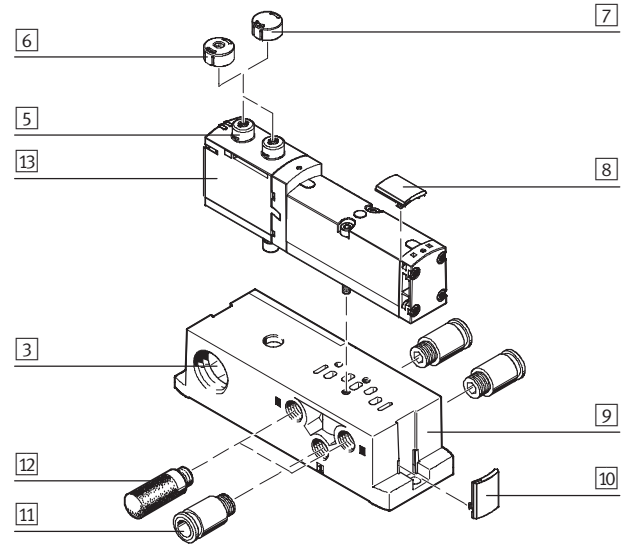
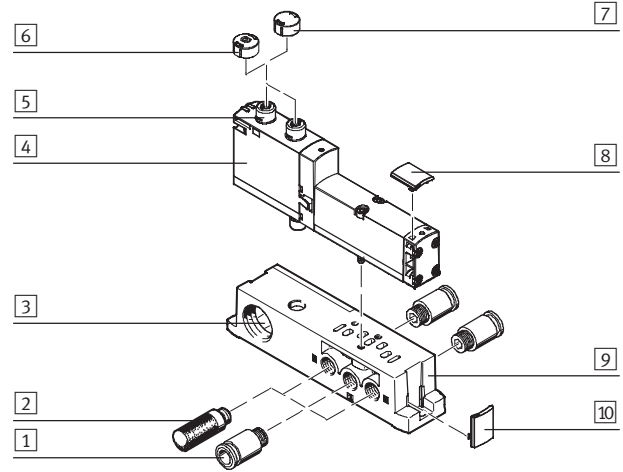

	Brief description	→ Page	
1	Fitting	G1/8 for supply/exhaust ports (1, 3, 5) and working ports (2, 4)	99
2	Silencer	G1/8 for supply/exhaust ports (1, 3, 5)	99
3	Manifold connection ¹⁾	4-pin, configured by the user	-
4	VSVA valve	Width 18 mm	91
5	Manual override	By pushing/detenting, per solenoid coil	-
6	Cover cap	For manual override, pushing	99
7	Cover cap	For manual override, covered	99
8	Inscription label holder	For valves	99
9	Individual subbase	For valve VSVA	94
10	Inscription label holder	For manifold blocks	99
11	Fitting	G1/4 for supply/exhaust ports (1, 3, 5) and working ports (2, 4)	99
12	Silencer	G1/4 for supply/exhaust ports (1, 3, 5)	99
13	VSVA valve	Width 26 mm	91

1) 24 VDC or 110 VAC

Overview – Single Subbases

Valve Manifolds Type 44 VTSA – Metric Series

Individual Subbase

Width 42 mm with spring-loaded manifold/open end

Width 42 mm with M12 plug

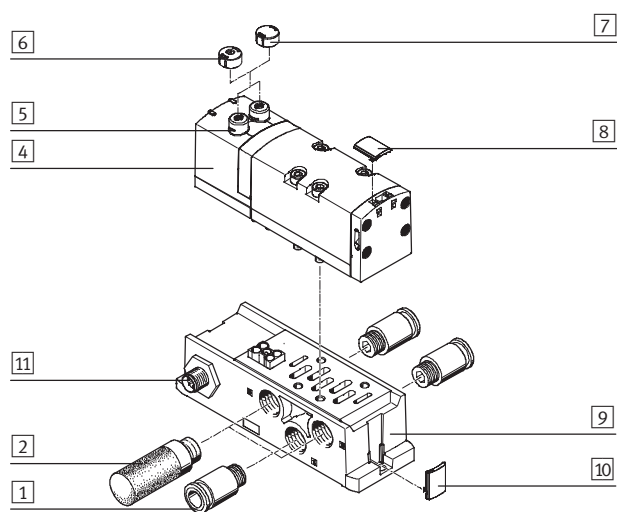
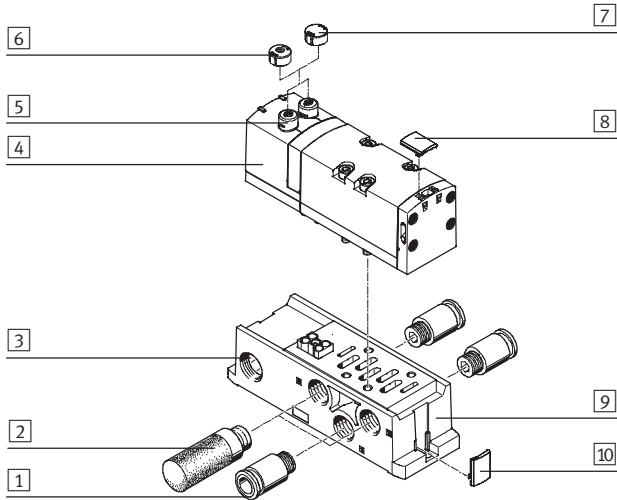

	Brief description	→ Page	
1	Fitting	G $\frac{3}{8}$ for supply/exhaust ports (1, 3, 5) and working ports (2, 4)	99
2	Silencer	G $\frac{3}{8}$ for supply/exhaust ports (1, 3, 5)	99
3	Clamped manifold connection/open end ¹⁾	4-pin, configured by the user	–
4	VSVA valve	Width 42 mm	91
5	Manual override	Pushing/detenting, per solenoid coil	–
6	Cover cap	For manual override, pushing	99
7	Cover cap	For manual override, covered	99
8	Inscription label holder	For valves	99
9	Individual subbase	For valve VSVA	94
10	Inscription label holder	For manifold blocks	99
11	Electrical connection M12 ²⁾	4-pin	–

1) 24 V DC or 110 V AC

2) Only for 24 V DC

Overview – Individual Connection

Valve Manifolds Type 44 VTSA, Type 45 VTSA-F – Metric Series

Valve Manifold with Individual Connection

Order code:

- 44E for the electrical components
- 45E for the electrical components
- 44P for the pneumatic components
- 45P for the pneumatic components

Valve manifolds with individual connection can be expanded with up to 20 valves with max. 20 solenoid coils.

The manifold subbases width 18 and 26 mm are either prepared for:

- 2 single solenoid valves
- 2 double solenoid valves

The manifold subbases width 42 mm are prepared for:

- 1 single solenoid valve
- 1 double solenoid valve depending on the size.

- Double solenoid valve positions can be fitted with any valve or a blanking plate.
- Single solenoid valve positions can only be fitted with single solenoid valves or a blanking plate.

The electrical connection is established via a 5-pin M12 plug.

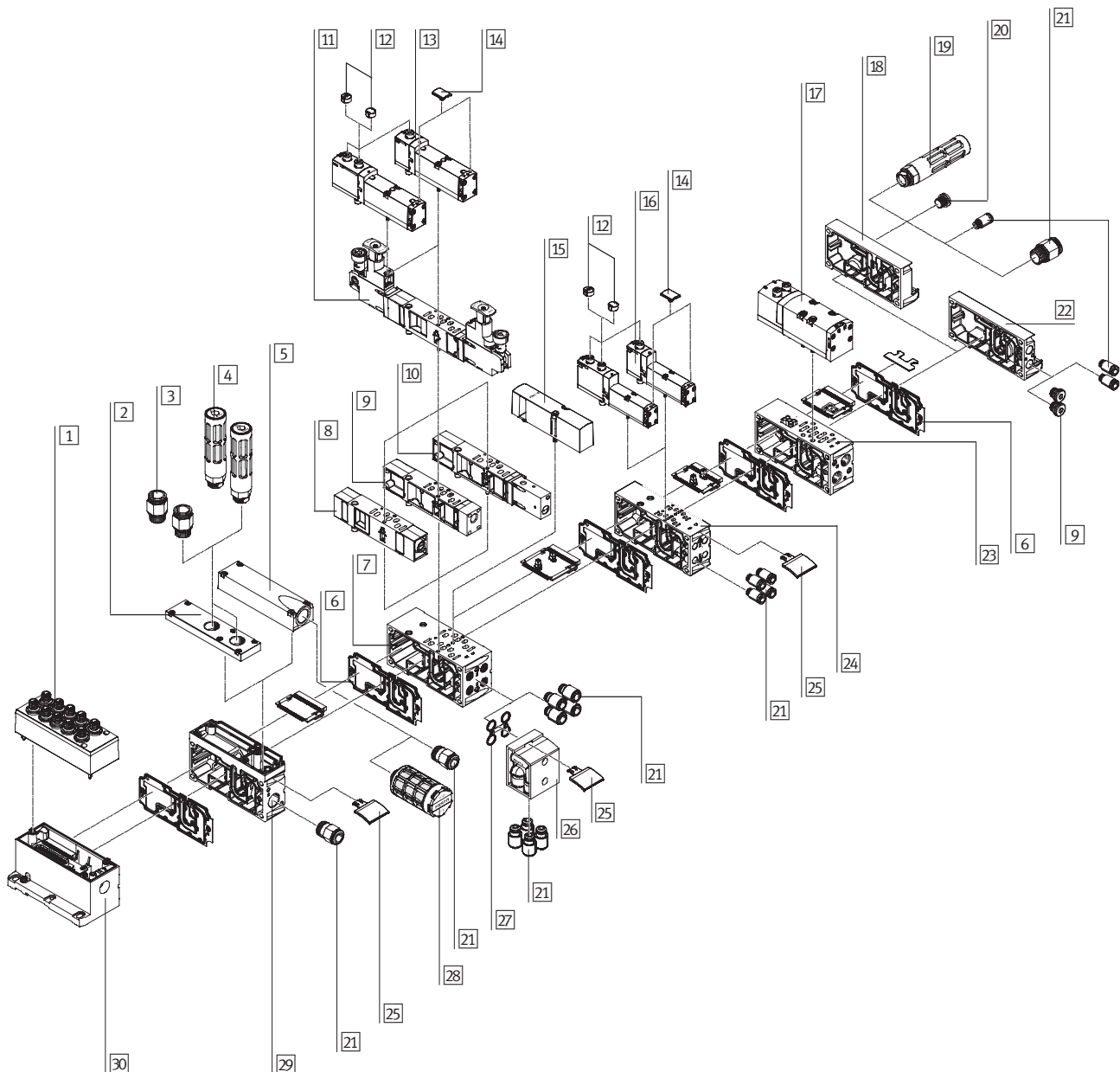

Overview – Individual Connection

Valve Manifolds Type 44 VTSA, Type 45 VTSA-F – Metric Series

Valve Manifold with Individual Connection			
	Brief description	→ Page	
1	Cover	For individual connection	97
2	Exhaust plate	Ports 3 and 5 separated	95
3	Fittings	For supply plate	99
4	Silencer	For supply plate	99
5	Exhaust port cover	For ducted exhaust air (ports 3 and 5 combined)	95
6	Duct separation/seal		95
7	Manifold subbase	For valves with a width of 26 mm	93
8	Flow control plate		97
9	Vertical supply plate		95
10	Vertical shut-off plate		97
11	Pressure regulator plate		96
12	Cover cap	For manual override, pushing, covered	99
13	Valve	Width 26 mm	91
14	Inscription label holder	For valve	99
15	Blanking plate	For unused valve position (vacant position)	99
16	Valve	Width 18 mm	91
17	Valve	Width 42 mm (type 44 only)	93
18	Right-hand end plate		93
19	Silencer	For end plate	99
20	Blanking plugs		100
21	Fittings		99
22	End plate with pilot air selector		93
23	Manifold subbase	For valves with a width of 42 mm (type 44 only)	93
24	Manifold subbase	For valves with a width of 18 mm	93
25	Inscription label holder	For supply plate, subbase, 90° connection plate	99
26	90° connection plate		95
27	Seals		95
28	Silencer		99
29	Supply plate		95
30	Multi-pin plug connection	Individual connection with M12, 10-way or 6-way (including cover)	97

Note

The choice of silencer to be used depends on the type of vertical stacking of the valve positions to the left and the right of the supply plate.

Exhaust port cover [5] with plastic exhaust air silencer type U-1/2
 – A pressure regulator plate

Exhaust port cover [5] with metal exhaust air silencer type U-1/2-B
 – P pressure regulator plate
 – B pressure regulator plate
 – AB pressure regulator plate
 – Vertical shut-off plate
 – Vertical supply plate
 – Flow control plate

Pneumatic Components

Valve Manifolds Type 44 VTSA, Type 45 VTSA-F – Metric Series

Subbase Valve

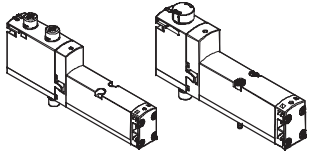

VTSA/VTSA-F offers a comprehensive range of valve functions. All valves are equipped with piston spool and patented sealing system which facilitate efficient sealing, a broad pressure range and long service life.

Subbase valves can be quickly replaced since the tubing connections remain on the subbase. Irrespective of the valve function there are subbase valves with one solenoid coil (single solenoid) or with two solenoid coils for double solenoid or double valve functions.

Reverse operation

Select reverse operation (code Z) if you wish to operate an actuator (cylinder) with different pressures for the forward and return stroke. It must be noted here that these valves must be operated via a separate pressure zone.

Blanking Plate

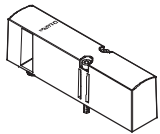

Plate without valve function for reserving valve positions on a valve manifold.

Valves and blanking plates are attached to the manifold subbase using two screws.

Valve Function					
Code	Circuit symbol	Width			Description
		18 mm	26 mm	42 mm	
M		■	■	■	5/2-way valve, single solenoid • Pneumatic spring return
O		■	■	■	5/2-way valve, single solenoid • Spring return
J		■	■	■	5/2-way valve, double solenoid
D		■	■	■	5/2-way valve, double solenoid • Dominant signal with port 14 on the control side
N		■	■	■	2x 3/2-way valve, single solenoid • Normally open • Pneumatic spring return
K		■	■	■	2x 3/2-way valve, single solenoid • Normally closed • Pneumatic spring return

Pneumatic Components

Valve Manifolds Type 44 VTSA, Type 45 VTSA-F – Metric Series



Valve Function					
Code	Circuit symbol	Width			Description
		18 mm	26 mm	42 mm	
H		■	■	■	2x 3/2-way valve, single solenoid <ul style="list-style-type: none"> • Normal position <ul style="list-style-type: none"> – 1x closed – 1x open • Pneumatic spring return • Operating pressure > 3 bar
B		■	■	■	5/3-way valve <ul style="list-style-type: none"> • Mid-position pressurized¹⁾ • Spring force return
G		■	■	■	5/3-way valve <ul style="list-style-type: none"> • Mid-position closed¹⁾ • Spring force return
E		■	■	■	5/3-way valve <ul style="list-style-type: none"> • Mid-position exhausted¹⁾ • Spring force return
P		■	■	■	2x 3/2-way valve, single solenoid <ul style="list-style-type: none"> • Reverse operation • Normally open • Pneumatic spring return
Q		■	■	■	2x 3/2-way valve, single solenoid <ul style="list-style-type: none"> • Reverse operation • Normally closed • Pneumatic spring return
R		■	■	■	2x 3/2-way valve, single solenoid <ul style="list-style-type: none"> • Reverse operation • Normal position <ul style="list-style-type: none"> – 1x closed – 1x open • Pneumatic spring return
L		■	■	■	For valve manifold only: Blanking plate for vacant valve position

1) If neither solenoid coil is energized, the valve moves to its mid-position by means of spring force.
 If both coils are energized at the same time, the valve remains in the previously assumed switching position.

Design	
Valve replacement The valves are attached to the metal manifold subbase using two screws. This means that they can be easily replaced. The high-quality of the manifold subbase guarantees good long-term sealing tightness.	Expansion Vacant positions can be equipped with valves at a later date. The dimensions, mounting points and existing pneumatic installations remain unchanged during this process. The order code VSVA-... is located on the front of the valve beneath the manual override.

Pneumatic Components

Valve Manifolds Type 44 VTSA, Type 45 VTSA-F – Metric Series

Vertical Stacking

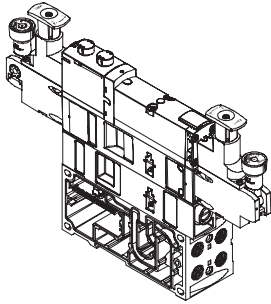

Additional function units can be added to each valve position between the subbase and the valve. These functions, designated as vertical stacking, facilitate special functioning or control

of the respective individual valve position. Combinations of several valve sizes on one valve manifold are possible.

Note

The operation of the components should be checked when combining multiple vertical stacking components.

The following combination of reversible valve manifolds with vertical stacking components is not permitted:

- Reversible pressure regulating plates
- Throttle plates
- Vertical isolating plates
- Vertical supply plates

Vertical stacking components

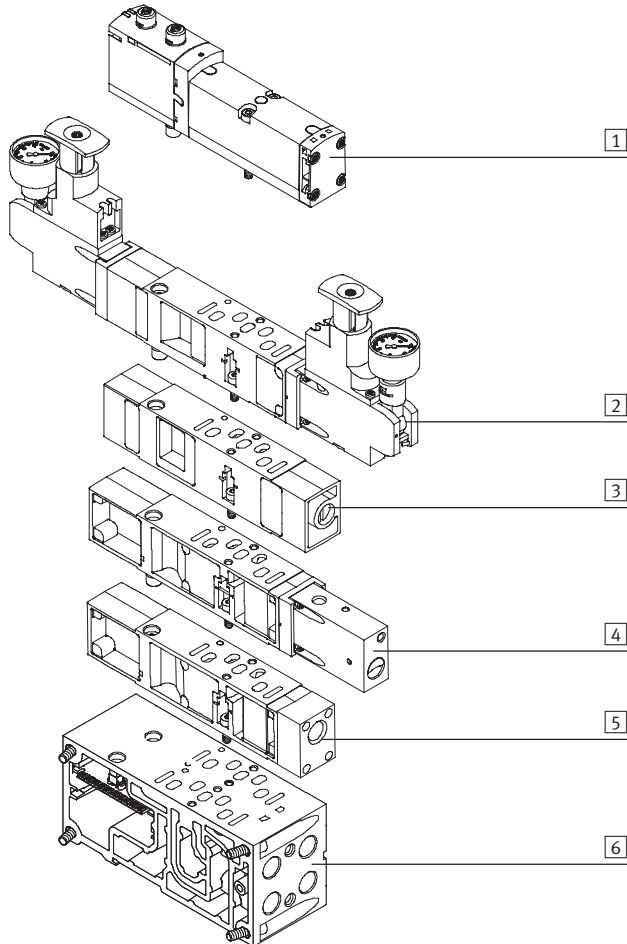

The following component sequence is recommended for valve positions with vertical stacking:

- 1 ISO valve
- 2 Pressure regulator plate
- 3 Flow control plate
- 4 Vertical shut-off plate
- 5 Vertical supply plate
- 6 Manifold subbase

Pneumatic Components

Valve Manifolds Type 44 VTSA, Type 45 VTSA-F – Metric Series

Vertical Stacking

Pressure regulator plate

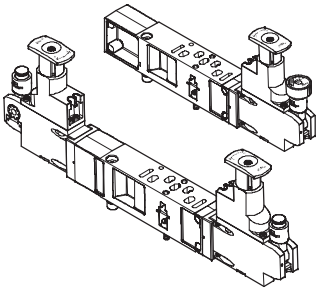

An adjustable pressure regulator can be installed between the subbase and the valve in order to control the force of the respective actuator.

This pressure regulating valve maintains an essentially constant output pressure (secondary side) independent of pressure fluctuations (primary side) and air consumption.

Standard version:

- Standard port pattern to ISO 15407-2 or ISO 5599-2 (type 44 only)
- For supply pressure up to 6 bar or up to 10 bar
- Without pressure gauge (optional)
- Regulator knob with 3 positions (locked, reference position, free running)

Mode of operation of the pressure regulating plate (P regulation) for port 1; code: ZA, ZF

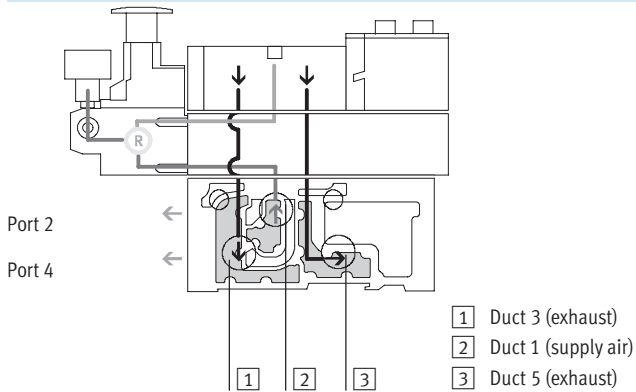

This pressure regulator regulates the pressure before the valve in duct 1. Ducts 2 and 4 thus have the same regulated pressure.

During venting, the exhaust flow in the valve is from duct 2 to duct 3 and from duct 4 to duct 5.

Advantages

- The pressure regulator is not affected by venting, as the pressure is regulated before the valve.
- The pressure regulator can always be adjusted, as the pressure from the valve manifold is always present.

Application examples

- An equal working pressure is required at working ports 2 and 4
- A lower working pressure (e.g. 3 bar) than the operating pressure present on the valve manifold (e.g. 8 bar) is required.

Mode of operation of the pressure regulating plate (A/B regulation) for ports 2 and 4; code: ZD, ZI

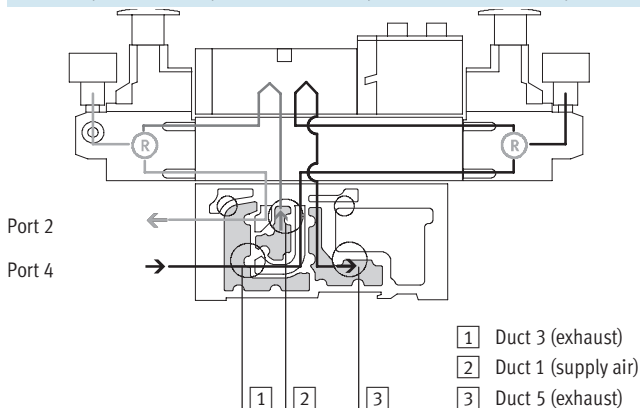

This pressure regulator regulates the pressure in ducts 2 and 4 after the pressure medium flows through the valve. During venting, the exhaust flow in the valve is from duct 2 to duct 3 and from duct 4 to duct 5 via the pressure regulator.

Example with the following switching position:
The supply air flows from duct 1 of the manifold subbase through the valve to duct 2, it is then regulated and made available at port 2 of the manifold subbase. At the same time, venting takes place via duct 4 of the manifold subbase, via the regulator and via the valve into duct 5 of the manifold subbase.

Restrictions

- The pressure regulator cannot be adjusted in the exhaust position. For example, the pressure regulator for duct 4 cannot be adjusted when the valve is pressurized in the switching position from duct 1 to duct 2 and exhausted from duct 4 to duct 5.

Application examples

- When two different working pressures are required instead of the valve manifold operating pressure at ports 2 and 4.

Pneumatic Components

Valve Manifolds Type 44 VTSA, Type 45 VTSA-F – Metric Series

Vertical Stacking

Mode of operation of the pressure regulating plate (A/B regulation, reversible) for ports 2 and 4, reversible; code: ZE, ZI

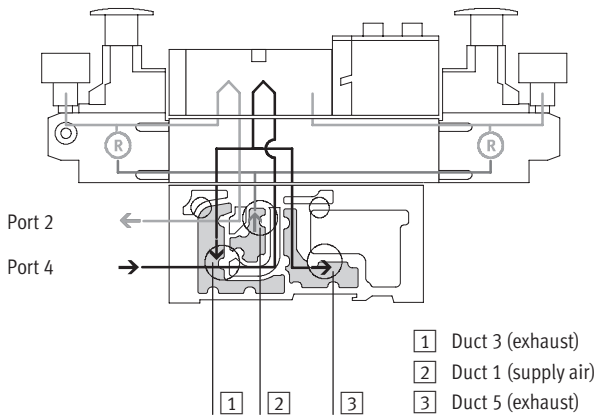

With this pressure regulator, the supply air (duct 1) is split and routed directly to both pressure regulators. The regulated compressed air is present in ducts 3 and 5 on the valve. The valve is thus operated in reversible mode. This means

- Duct 3 routes the working pressure to port 2
- Duct 5 routes the working pressure to port 4

Example with the following switching position:
The supply air in duct 1 is split among ducts 3 and 5 in the regulator and flows from here to the valve. In the valve, the supply air is routed to port 2 of the manifold subbase. The exhaust air is simultaneously routed via duct 4 of the manifold subbase and via the valve to regulator duct 1, where it is split between ducts 3 and 5 and then drawn off via the manifold subbase.

Application examples

- When two different pressures are required in ducts 2 and 4 instead of the operating pressure.
- When fast exhaust performance is required.
- When the pressure regulator must always be adjustable.

Note

- Reversible pressure regulating plates may only be combined with valves that can be operated in reversible mode.
- Valves in valve positions with vertical shut-off plates are operated with internal pilot air supply, even when the valve manifold is operated with external pilot air supply.
- The following combination of reversible valve manifolds with vertical stacking components is not permitted:
 - Reversible pressure regulating plates
 - Flow control plates
 - Vertical shut-off plates
 - Vertical supply plates

Advantages

- Fast cycle times.
- 50% higher exhaust flow rate, as air is not exhausted via the pressure regulator. The load on the pressure regulator is also reduced.
- No quick exhaust valves are required.
- Operating pressure is always present at the pressure regulator, as the pressure is regulated before the valve, i.e. the regulator can always be adjusted.

Disadvantages

- 2x 3/2-way valves (code N, K, H) not used, as pressure is present at ports 3 and 5.
- No practical combination with a flow control plate possible.

Pneumatic Components

Valve Manifolds Type 44 VTSA, Type 45 VTSA-F – Metric Series



Vertical Stacking – Pressure Regulating Plate								
Code	Type	Width			Supply pressure		Description	
		18 mm	26 mm	42 mm	6 bar	10 bar		
Pressure regulating plate for port 1 (P regulator)								
ZA		VABF-S4-...-R1C2-C-10	■	■	■	-	■	<ul style="list-style-type: none"> Regulates the operating pressure in duct 1 before the directional control valve
ZF		VABF-S4-...-R1C2-C-6	■	■	■	■	-	
Pressure regulating plate for port 2 (B regulator)								
ZC		VABF-S4-...-R2C2-C-10	■	■	■	-	■	<ul style="list-style-type: none"> Regulates the operating pressure in duct 2 after the directional control valve
ZH		VABF-S4-...-R2C2-C-6	■	■	■	■	-	
Pressure regulating plate for port 4 (A regulator)								
ZB		VABF-S4-...-R3C2-C-10	■	■	■	-	■	<ul style="list-style-type: none"> Regulates the operating pressure in duct 4 after the directional control valve
ZG		VABF-S4-...-R3C2-C-6	■	■	■	■	-	
Pressure regulating plate for ports 2 and 4 (AB regulator)								
ZD		VABF-S4-...-R4C2-C-10	■	■	■	-	■	<ul style="list-style-type: none"> Regulates the operating pressure in ducts 2 and 4 after the directional control valve
ZI		VABF-S4-...-R4C2-C-6	■	■	■	■	-	
Pressure regulating plate for port 2, reversible (B regulator)								
ZL		VABF-S4-...-R6C2-C-10	■	■	■	-	■	<ul style="list-style-type: none"> Reversible pressure regulator for port 2
ZN		VABF-S4-...-R6C2-C-6	■	■	■	■	-	
Pressure regulating plate for port 4, reversible (A regulator)								
ZK		VABF-S4-...-R7C2-C-10	■	■	■	-	■	<ul style="list-style-type: none"> Reversible pressure regulator for port 4
ZM		VABF-S4-...-R7C2-C-6	■	■	■	■	-	

Pneumatic Components

Valve Manifolds Type 44 VTSA, Type 45 VTSA-F – Metric Series



Vertical Stacking – Pressure Regulating Plate								
Code		Type	Width			Supply pressure		Description
			18 mm	26 mm	42 mm	6 bar	10 bar	
Pressure regulating plate for ports 2 and 4, reversible (AB regulator)								
ZE		VABF-S4-...-R5C2-C-10	■	■	■	-	■	<ul style="list-style-type: none"> • Reversible pressure regulator for ports 2 and 4 • Pressure regulation before the valve • Redirects the operating pressure from duct 1 to ducts 3 and 5 • Routes the exhaust air from duct 1 to ducts 3 and 5
ZJ		VABF-S4-...-R5C2-C-6	■	■	■	■	-	<p>Note</p> <p>This pressure regulating plate cannot be combined with standard 2x 3/2-way valves (code N, K, H). Reversible 2x 3/2-way valves (code P, Q, R) must not be operated in a separate pressure zone in combination with these pressure regulators.</p>

Pneumatic Components

Valve Manifolds Type 44 VTSA, Type 45 VTSA-F – Metric Series



Vertical Stacking – Flow Control Plate

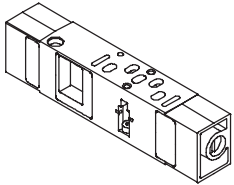

This plate is used for exhaust air flow control in ducts 3 and 5 of a valve in order to adjust the speed of the actuator.

Ducts 3 and 5 can be adjusted independently of each other.

Note

On reversible valve manifolds, supply air flow control takes place in ducts 3 and 5 before the valve.

Code	Type	Width			Description
		18 mm	26 mm	42 mm	
X	VABF-S4-...F1B1-C	■	■	■	<ul style="list-style-type: none"> Controls the flow of exhaust air after the valve to ducts 3 and 5

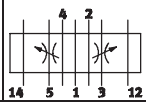

Vertical Stacking – Vertical Shut-off Plate

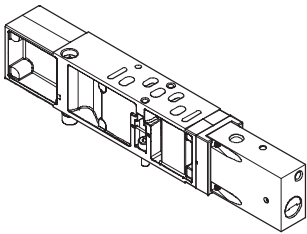

With this plate a valve can be shut off from the supply pressure of the manifold. This means that the valve can be removed without shutting off the pressure.

Following activation of the shut-off, the exhaust air/return air from the cylinder is drawn off via the M5 threaded connection.

Note

It must be ensured that the operating pressure of the valve manifold lies within the range of the required pilot pressure (i.e. min. 3 bar).

Code	Type	Width			Description
		18 mm	26 mm	42 mm	
ZT	VABF-S4-...L1D1-C	■	■	■	<ul style="list-style-type: none"> 2/2-way valve for shutting off the operating pressure at the valve position Blocks ducts 12 and 14 for the valve position Supplies the valve position with internal pilot air

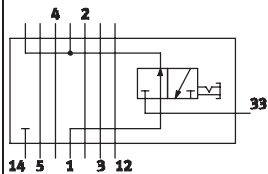

Vertical Stacking – Vertical Supply Plate

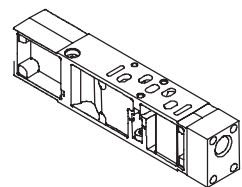

With this plate a valve can be supplied with individual operating pressure independently of the operating pressure of the manifold.

Code	Type	Width			Description
		18 mm	26 mm	42 mm	
ZU	VABF-S4-...P1A3-...	■	■	■	<ul style="list-style-type: none"> Plate with port 11 for supplying an individual operating pressure for a valve position

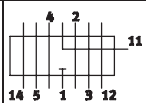

Pneumatic Components

Valve Manifolds Type 44 VTSA, Type 45 VTSA-F – Metric Series



Manifold Subbase

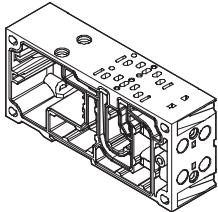

VTSA/VTSA-F is based on a modular system which consists of manifold subbases and valves. Manifold subbases are available for valve width 18 mm and width 26 mm in a double grid, i.e. two valves per manifold subbase. For width 42 mm (type 44 only) there are manifold subbases for one valve per subbase .

The manifold subbase contains a ducting seal and electrical linking. They can be freely mixed within a valve manifold. The manifold subbases are screwed together and thus form the support system for the valves. Inside the manifold blocks are the connection channels for supplying compressed air to and venting from the

valves on the manifold as well as the working lines for the pneumatic cylinders for each valve. Each manifold subbase is connected to the next using four screws. Individual manifold sections can be isolated and further manifold subbases inserted by loosening these screws. This ensures that the valve manifold can be rapidly and reliably expanded.

Port Patterns on the Manifold Subbase

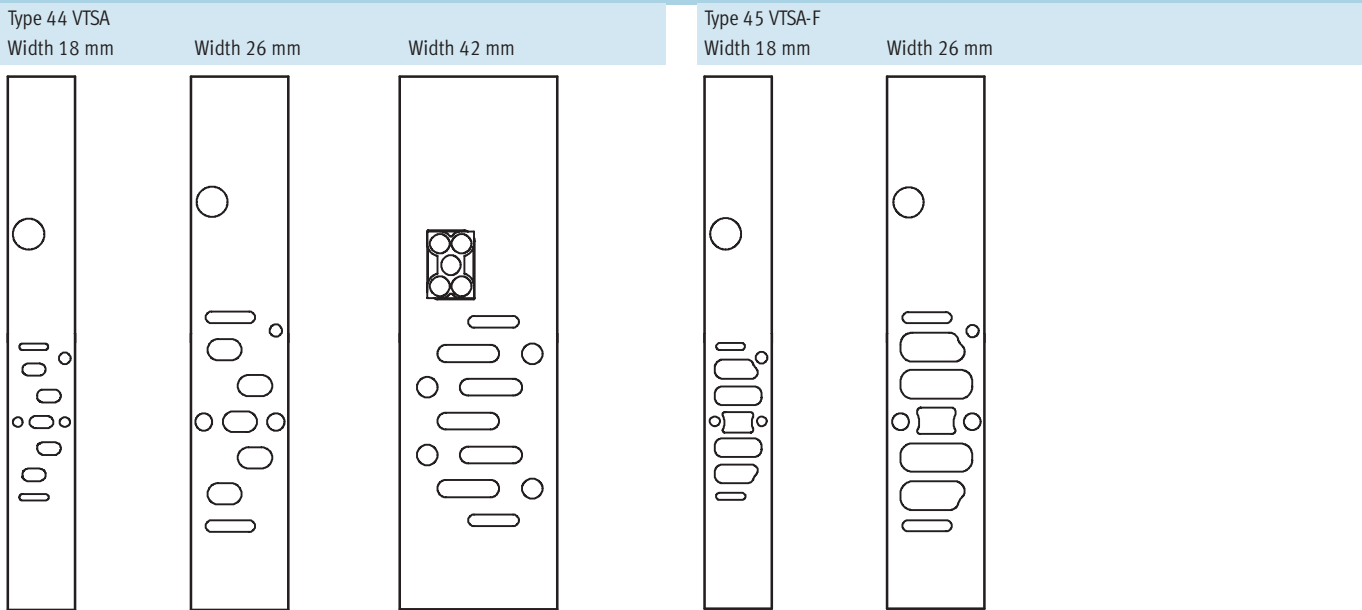

90° Connection Plate for Working Ports (2, 4) of the Manifold Subbases

Code	Image	Type	Width			Ports	Working ports (2, 4) in the 90° connection plate
			18 mm	26 mm	42 mm		
P		Threaded connection: VABF-S4-...-A2G2-G...	■	■	■	2 and 4	Outlet at bottom <ul style="list-style-type: none"> • Connection size for 18 mm width: G$\frac{1}{8}$ • Connection size for 26 mm width: G$\frac{1}{4}$ • Connection size for 42 mm width: G$\frac{3}{8}$

Pneumatic Components

Valve Manifolds Type 44 VTSA, Type 45 VTSA-F – Metric Series

Manifold Subbase Variants – Type 44 VTSA							
Code	Image	Type	Width			No. of valve positions/solenoid coils	Working ports (2, 4) on manifold subbase
			18 mm	26 mm	42 mm		
Manifold subbase for multi-pin plug/fieldbus connection for double solenoid valves							
A AK		Threaded connection: VABV-S4-2S-G18-2T2	■	-	-	2/4	• Connection sizes for 18 mm width: G $\frac{1}{8}$, QS-G $\frac{1}{8}$ -8, QS-G $\frac{1}{8}$ -6
B BK		Threaded connection: VABV-S4-1S-G14-2T2	-	■	-	2/4	• Connection sizes for 26 mm width: G $\frac{1}{4}$, QS-G $\frac{1}{4}$ -10, QS-G $\frac{1}{4}$ -8
C CK		Threaded connection: VABV-S2-1S-G38-2T2	-	-	■	2/4	• Connection sizes for 42 mm width: G $\frac{3}{8}$ QS-G $\frac{3}{8}$ -12, QS-G $\frac{3}{8}$ -10
Manifold subbase for multi-pin plug/fieldbus connection for single solenoid valves							
E EK		Threaded connection: VABV-S4-2S-G18-2T1	■	-	-	2/2	• Connection sizes for 18 mm width: G $\frac{1}{8}$, QS-G $\frac{1}{8}$ -8, QS-G $\frac{1}{8}$ -6
F FK		Threaded connection: VABV-S4-1S-G14-2T1	-	■	-	2/2	• Connection sizes for 26 mm width: G $\frac{1}{4}$, QS-G $\frac{1}{4}$ -10, QS-G $\frac{1}{4}$ -8
G GK		Threaded connection: VABV-S2-1S-G38-2T1	-	-	■	2/2	• Connection sizes for 42 mm width: G $\frac{3}{8}$ QS-G $\frac{3}{8}$ -12, QS-G $\frac{3}{8}$ -10

Manifold Subbase Variants – Type 45 VTSA-F						
Code	Image	Type	Width		No. of valve positions/solenoid coils	Working ports (2, 4) on manifold subbase
			18 mm	26 mm		
Manifold subbase for multi-pin plug/fieldbus connection for double solenoid valves						
A AK		Threaded connection: VABV-S4-2HS-G18-2T2	■	-	2/4	• Connection sizes for 18 mm width: G $\frac{1}{8}$, QS-G $\frac{1}{8}$ -8, QS-G $\frac{1}{8}$ -6
B BK		Threaded connection: VABV-S4-1HS-G14-2T2	-	■	2/4	• Connection sizes for 26 mm width: G $\frac{1}{4}$, QS-G $\frac{1}{4}$ -10, QS-G $\frac{1}{4}$ -8
Manifold subbase for multi-pin plug/fieldbus connection for single solenoid valves						
E EK		Threaded connection: VABV-S4-2HS-G18-2T1	■	-	2/2	• Connection sizes for 18 mm width: G $\frac{1}{8}$, QS-G $\frac{1}{8}$ -8, QS-G $\frac{1}{8}$ -6
F FK		Threaded connection: VABV-S4-1HS-G14-2T1	-	■	2/2	• Connection sizes for 26 mm width: G $\frac{1}{4}$, QS-G $\frac{1}{4}$ -10, QS-G $\frac{1}{4}$ -8

Pneumatic Components

Valve Manifolds Type 44 VTSA, Type 45 VTSA-F – Metric Series

Compressed Air Supply and Venting

Right-hand end plate
– Code V

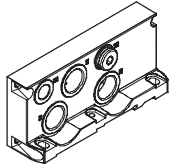

Port configuration for supply plates
Exhaust air 3/5 separated
– Code K

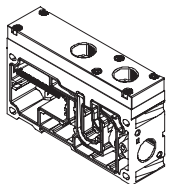

Right-hand end plate
– Code X

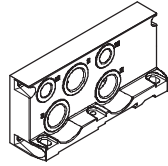

Port configuration for supply plates
Exhaust port 3/5 common
– Code L

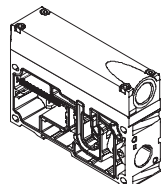

End plate with pilot air selector
– Code Y, U, Z, W

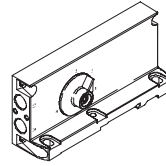

The valve manifold VTSA/VTSA-F can be supplied with compressed air at one or more points. This is a reliable way of ensuring that all functional components of the manifold will always offer good performance, even with large-scale expansions. The valve manifold is supplied via supply plates (max. 16 per manifold) or via an end plate. Venting is performed either using silencers or ports for ducted exhaust air on the supply plates and/or on the right-hand end plate. There are two types of supply plates:

- Exhaust port 3/5 common
- Exhaust 3/5 port separated

Pilot air supply

The port for the pneumatic supply is located on the supply plates or the right-hand end plate. The ports differ for the following types of pilot air supply:

- Internal
- External

Internal pilot air supply

Internal pilot air supply can be selected if the required working pressure is between 3 and 10 bar. The pilot air supply is then branched from the compressed air supply 1 using an internal connection. Port 14 on the right-hand end plate is sealed with a blanking plug.

External pilot air supply

If the supply pressure is less than 3 bar, you must operate your valve manifold using external pilot air supply. The pilot air supply is supplied via port 14 on the right-hand end plate to this end. This is the case even if the valve manifold is operated with different pressure zones.

Note

If a gradual pressure build-up in the system using a pressurized on-off valve is required, external pilot supply air where the control pressure applied during switch-on is already very high should be selected.

Right-hand End Plate

Different right-hand end plates are available.

With the following two end plates, the outgoing direction of the ports is aligned with the horizontal stacking direction.

Right-hand end plates with supply air/exhaust air

- Internal pilot air supply: Code V
- External pilot air supply: Code X

For end plates with pilot air selector, the outgoing direction of the ports is to the front face of the valve manifold. This means that all of the ports on the manifold can be combined in one outgoing direction.

The special feature of the end plates with pilot air selector is the selector switch itself, which has four settings for different pilot air supply/pilot exhaust air.

End plates with pilot air selector switch set at the factory for:

- Internal pilot air supply: Code Y
- External pilot air supply: Code Z
- Internal pilot air supply, ducted pilot exhaust air: Code U
- External pilot air supply, ducted pilot exhaust air: Code W

Note

The end plate with pilot air selector must be used in combination with a supply plate. The reversible 3/2-way valves (code P, Q, R) must only be operated in selector position 1 or 2 (code Z, Y).

Right-hand End Plate with Coding Cap

Code	Selector position
Z	1
Y	2
W	3
U	4

Pneumatic Components

Valve Manifolds Type 44 VTSA, Type 45 VTSA-F – Metric Series

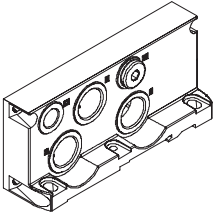
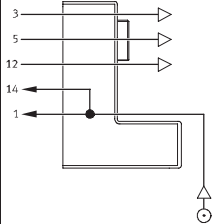
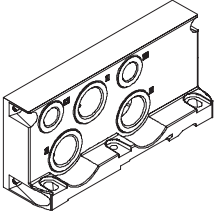
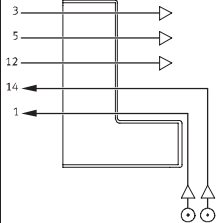
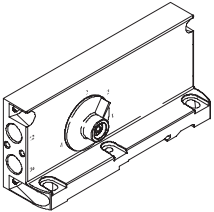
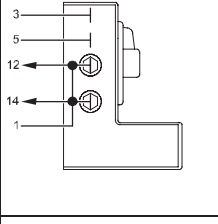
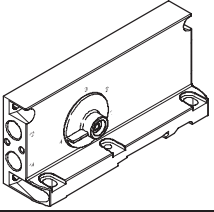
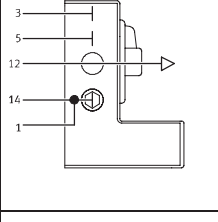
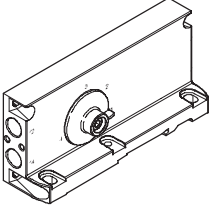
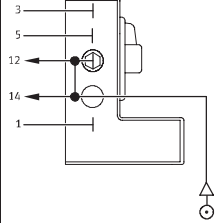
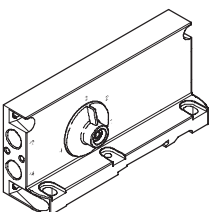
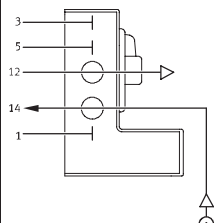

Right-hand End Plate						
Code	Type of compressed air supply and pilot air supply	Width			Description	
		18 mm	26 mm	42 mm		
Right-hand end plate						
V			■	■	■	Supply air/exhaust air, internal pilot air supply, silencer <ul style="list-style-type: none"> • Pilot air supply is branched internally from port 1 • Port 14 is sealed with a blanking plug • Exhaust 3/5 via silencer • For operating pressure in the range 3 ... 10 bar • Pilot exhaust¹⁾
X			■	■	■	Supply air/exhaust air, external pilot air supply, silencer <ul style="list-style-type: none"> • Pilot air supply between 2 and 10 bar is connected at port 14 • Exhaust 3/5 via silencer • For operating pressure in the range -0.9 ... 10 bar (suitable for vacuum) • Pilot exhaust¹⁾
Code ²⁾	End plate with pilot air selector					
Y (2)			■	■	■	Internal pilot air supply <ul style="list-style-type: none"> • Pilot air supply is branched internally from port 1 • Ports 1/12/14 are internally connected • Ports 12/14 are sealed with blanking plugs • Pilot exhaust air is vented via valve housing
U (4)			■	■	■	Internal pilot supply air, ducted exhaust air <ul style="list-style-type: none"> • Pilot air supply is branched internally from port 1 • Ports 1/14 are internally connected • Port 14 is sealed with a blanking plug • Pilot exhaust via port 12 with silencer¹⁾
Z (1)			■	■	■	External pilot air supply <ul style="list-style-type: none"> • Pilot air supply is connected at port 14 • Port 12 is sealed with a blanking plug • Ports 12/14 are internally connected • Pilot exhaust air is vented via valve housing
W (3)			■	■	■	External pilot supply air, ducted exhaust air <ul style="list-style-type: none"> • Pilot air supply is connected at port 14 • Pilot exhaust via port 12 with silencer¹⁾

1) Ducted pilot exhaust air is only possible with turned seals on the valve
 2) Selector position in brackets

Pneumatic Components

Valve Manifolds Type 44 VTSA, Type 45 VTSA-F – Metric Series



Compressed Air Supply/Duct Separation

Additional supply plates can be used for larger manifolds or to create pressure zones.

These can be selected at any point before or after manifold subbases.

Supply plates contain the ports:

- Compressed air supply port (1)
- Exhaust port (3/5) common or separated

Depending on your order, the exhaust air ducts are either ducted or vented via silencers.

VTSA/VTSA-F with ducted exhaust air

With ducted exhaust air, venting can be performed via a supply plate or a right-hand end plate (code V or X).

If a duct separation is required, there are three different options:

- Duct separation 1, 3, 5: Code S
- Duct separation 1: Code T
- Duct separation 3, 5: Code R

If a combination of duct separation (S, T or R) and one or two supply plates is required, the following variants can be selected:

- Supply plate with duct separation on the left-hand side:
Code SU, TU, RU
- Supply plate with duct separation on the right-hand side:
Code US, UT, UR
- 2 supply plates with intermediate duct separation:
Code USU, UTU, URU

Supply Plates						
Code	Image	Type	Width			Description
			18 mm	26 mm	42 mm	
U		<ul style="list-style-type: none"> • Exhaust port 3/5 common For threaded connection: VABF-S6-10-P1A7-G12 • Exhaust air 3/5 separated For threaded connection: VABF-S6-10-P1A6-G12 	■	■	■	Supply plate without duct separation (no R, S or T selected)
SU TU RU			■	■	■	Supply plate with duct separation on left, if R, S or T selected
US UT UR			■	■	■	Supply plate with duct separation on right, if R, S or T selected
USU UTU URU			■	■	■	2 supply plates with duct separation in centre, if R, S or T selected

Pneumatic Components

Valve Manifolds Type 44 VTSA, Type 45 VTSA-F – Metric Series



Configuration of All Pneumatic Threaded Connections							
Code ¹⁾			Connection	Designation	Code M Push-in connector large	Code N Push-in connector small	
V		-	Right-hand end plate, internal pilot air supply, silencer				
			1	Compressed air/ vacuum supply	Push-in fitting	QS-G $\frac{1}{2}$ -16	QS-G $\frac{1}{2}$ -12
			3/5	Exhaust air	Via silencer	U- $\frac{1}{2}$ -B	U- $\frac{1}{2}$ -B
X		-	Right-hand end plate, external pilot air supply, silencer				
			1	Compressed air/ vacuum supply	Push-in fitting	QS-G $\frac{1}{2}$ -16	QS-G $\frac{1}{2}$ -12
			3/5	Exhaust air	Via silencer	U- $\frac{1}{2}$ -B	U- $\frac{1}{2}$ -B
Y (2)			End plate with pilot air selector, internal pilot air supply				
			12/14	Pilot air supply/ pilot exhaust air	Blanking plug/push-in fitting	B- $\frac{1}{4}$ / QS-G $\frac{1}{4}$ -10	B- $\frac{1}{4}$ / QS-G $\frac{1}{4}$ -8
			14	Pilot air supply	Push-in fitting	QS-G $\frac{1}{4}$ -10	QS-G $\frac{1}{4}$ -8
U (4)			End plate with pilot air selector, internal pilot air supply, ducted exhaust air				
			12/14	Pilot air supply/ pilot exhaust air	Blanking plug/blanking plug	B- $\frac{1}{4}$ / B- $\frac{1}{4}$	B- $\frac{1}{4}$ / B- $\frac{1}{4}$
Z (1)			End plate with pilot air selector, external pilot air supply				
			12/14	Pilot air supply/ pilot exhaust air	Push-in fitting or silencer/push-in fitting	QS-G $\frac{1}{4}$ -10 or U- $\frac{1}{4}$ / QS-G $\frac{1}{4}$ -10	QS-G $\frac{1}{4}$ -8 or U- $\frac{1}{4}$ / QS-G $\frac{1}{4}$ -8
W (3)			End plate with pilot air selector, external pilot air supply, ducted exhaust air				
			12/14	Pilot air supply/ pilot exhaust air	Push-in fitting or silencer/blanking plug	QS-G $\frac{1}{4}$ -10 or U- $\frac{1}{4}$ / B- $\frac{1}{4}$	QS-G $\frac{1}{4}$ -8 or U- $\frac{1}{4}$ / B- $\frac{1}{4}$

1) Selector position in brackets

Pneumatic Components

Valve Manifolds Type 44 VTSA, Type 45 VTSA-F – Metric Series

Creation of Pressure Zones and Separation of Exhaust Air

The valve manifold VTSA/VTSA-F offers a number of options for creating pressure zones if different working pressures are required.

Pressure zones are created by isolating the internal supply ducts between the manifold subbases using an appropriate duct separation.

Compressed air is supplied and vented by using a supply plate.

The position of the supply plates and duct separations can be freely selected for VTSA/VTSA-F.

Duct separations are integrated ex-works as per your order.

Duct order and separations can be distinguished by their coding, even when the valve manifold is assembled.

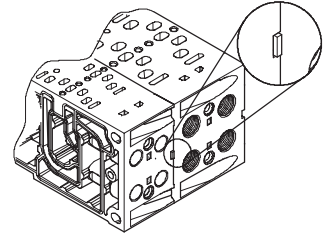

Creating Pressure Zones						
Code	Separating seal		Width			Description
	Pictorial examples	Coding	18 mm	26 mm	42 mm	
T			■	■	■	Duct 1 separated
S			■	■	■	Duct 1 and 3/5 separated
R			■	■	■	Duct 3/5 separated

Pneumatic Components

Valve Manifolds Type 44 VTSA, Type 45 VTSA-F – Metric Series



Examples: Compressed Air Supply and Pilot Air Supply, Right-hand End Plate

Internal pilot air supply, silencer/ducted exhaust air

Right-hand end plate
Code V

The diagram opposite shows an example for the configuration and connection of the compressed air supply with internal pilot supply air. Port 14 on the right-hand end plate is tightly sealed. Exhaust air 3/5 is drawn off via the silencer. Duct separations can be used optionally to create pressure zones.

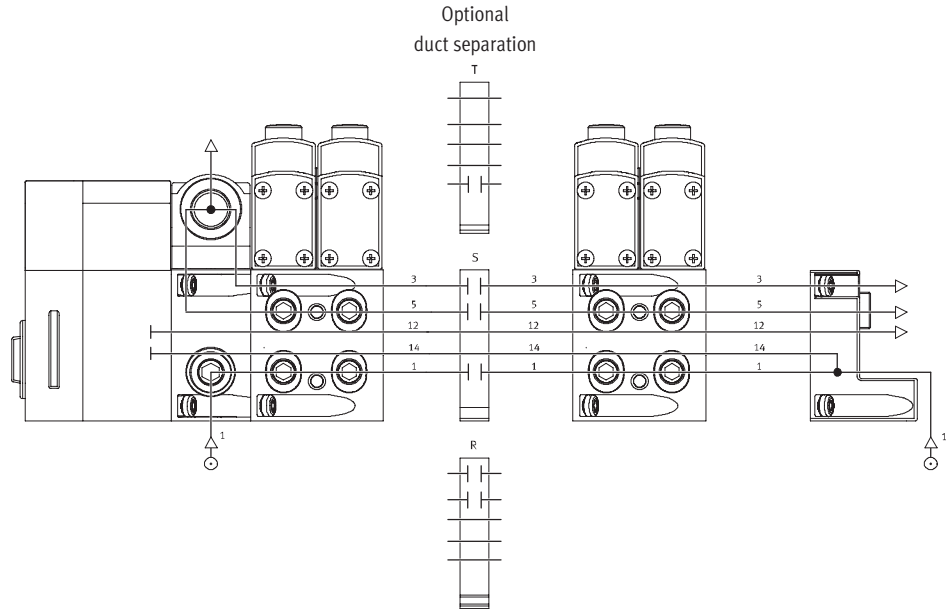

External pilot air supply, silencer/ducted exhaust air

Right-hand end plate
Code X

The diagram opposite shows an example for the configuration and connection of the compressed air supply with external pilot supply air. Port 14 on the right-hand end plate is equipped with a fitting for this. Exhaust air 3/5 is drawn off via the silencer. Duct separations can be used optionally to create pressure zones.

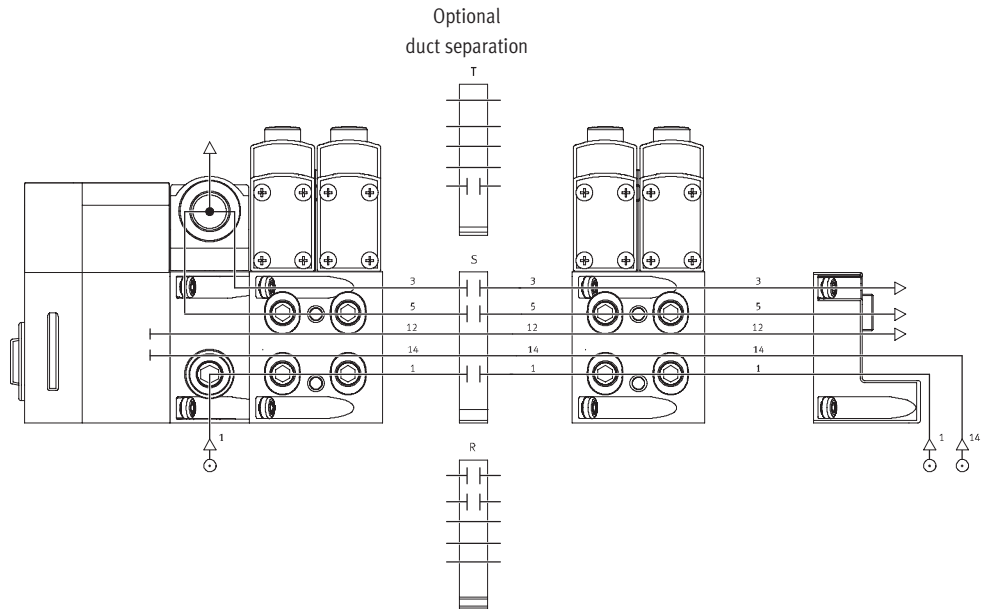

Pneumatic Components

Valve Manifolds Type 44 VTSA, Type 45 VTSA-F – Metric Series



Examples: Compressed Air Supply and Pilot Air Supply via End Plate with Pilot Air Selector

Internal pilot air supply, ducted exhaust air/silencer

Right-hand end plate
Code Y, U – code U shown

The diagram opposite shows an example for the configuration and connection of the compressed air supply with internal pilot supply air. Port 14 on the right-hand end plate is tightly sealed. Exhaust air 3/5 is ducted or drawn off via the silencer. Duct separations can be used optionally to create pressure zones.

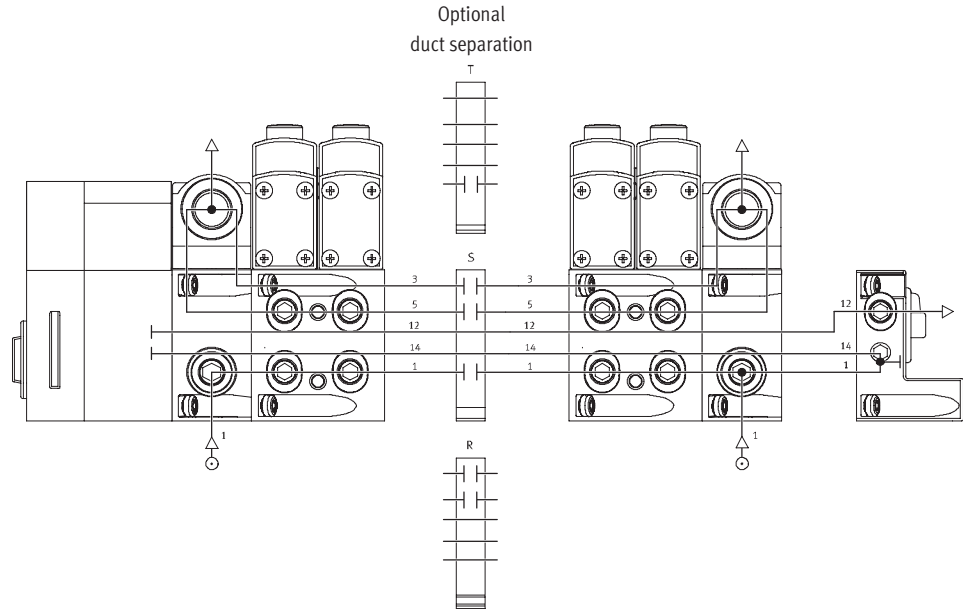

External pilot air supply, ducted exhaust air/silencer

Right-hand end plate
Code Z, W – code Z shown

The diagram opposite shows an example for the configuration and connection of the compressed air supply with external pilot supply air. Port 14 on the right-hand end plate is equipped with a fitting for this. Exhaust air 3/5 is ducted or drawn off via the silencer. Duct separations can be used optionally to create pressure zones.

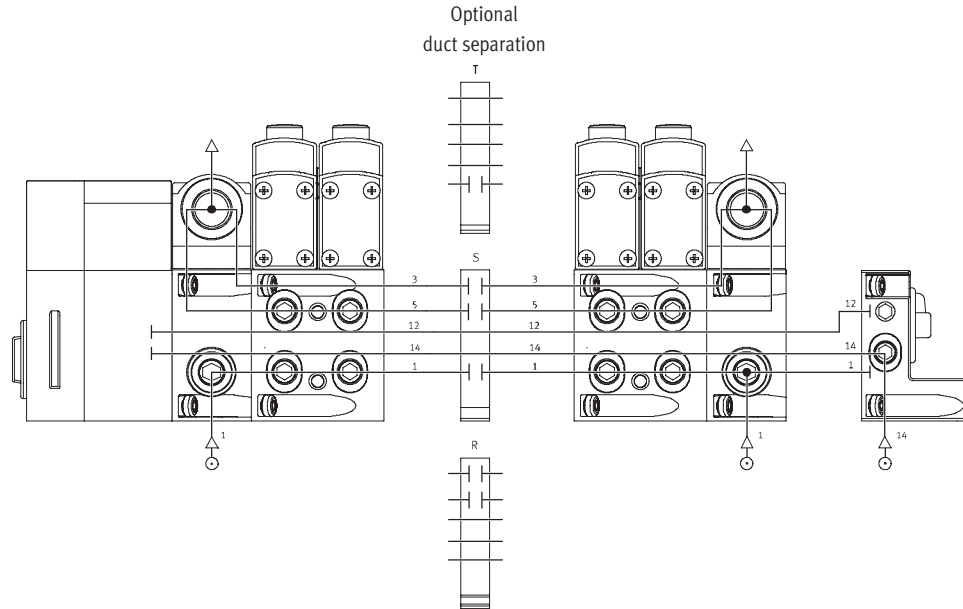

Pneumatic Components

Valve Manifolds Type 44 VTSA, Type 45 VTSA-F – Metric Series



Examples: Creation of Pressure Zones

VTSA/VTSA-F with CPX manifold connection

VTSA/VTSA-F allows the creation of up to 16 pressure zones (32 pressure zones if only size 1 (42 mm), ISO 5599-2, is fitted). The diagram shows an example for the configuration and connection of three pressure zones using duct separations – with internal pilot air supply.

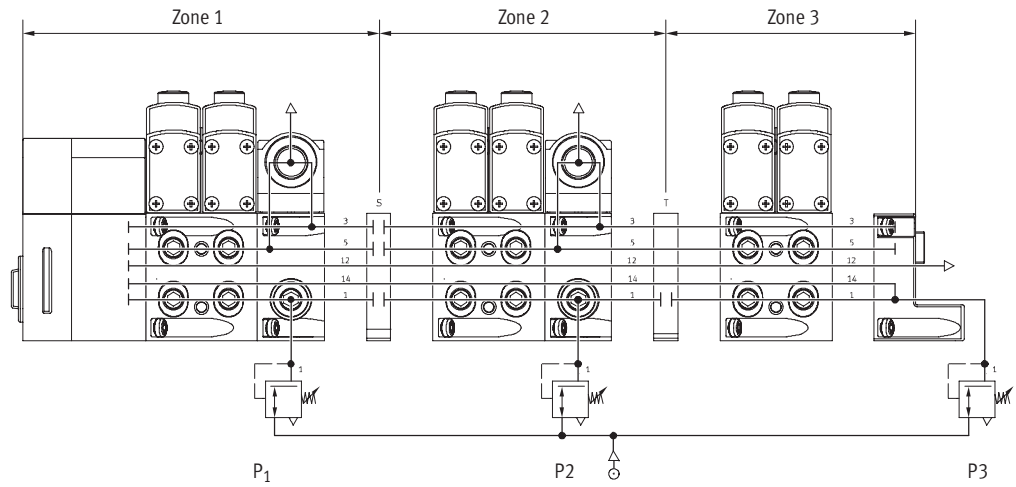

Electrical Components

Valve Manifolds Type 44 VTSA, Type 45 VTSA-F – Metric Series

Protective Circuit

Each VTSA/VTSA-F solenoid coil is protected with a spark arresting protective circuit as well as against reverse-polarity protection.

24 V DC version

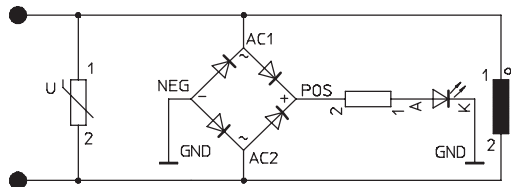

110 V AC version

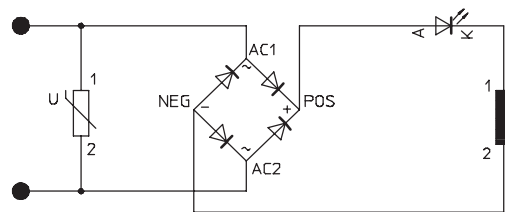

Individual Valve

Valves can also be used on individual subbases for actuators further away from the valve manifold.

- Electrical M12 connector, 4 pin 24 V DC

- Screw terminal connection for configuration by the user 24 V DC or 110 V AC

Electrical Connection, Individual Valve 24 V DC

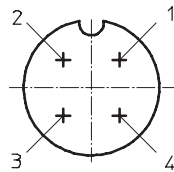
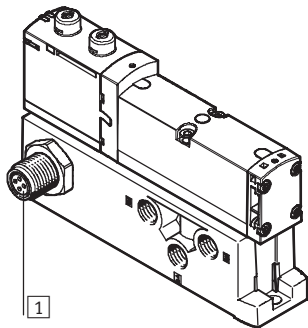

1 Connector plug M12x1, male, 4-pin to EN 61076-2-101

Pin allocation M12 on individual valve to ISO 20401

With positive logic:

- Pin1 – Not allocated
- Pin2 – 24 V DC for coil 12
- Pin3 – 0 V for coil 12 and 14 or
- Pin4 – 24 V DC for coil 14

With negative logic:

- Pin1 – Not allocated
- Pin2 – 0 V for coil 12
- Pin3 – 24 V DC for coil 12 and 14
- Pin4 – 0 V for coil 14

Electrical Connection, Individual Valve, 24 V DC or 110 V AC

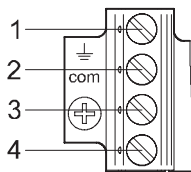
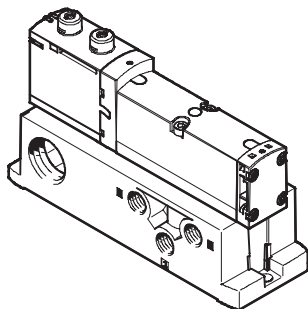

Terminal allocation for assembly by the user

With positive logic:

- 1 – Unused (with 110 V AC connection for earthing)
- 2 – 24 V DC for coil 12
- 3 – 0 V for coil 12 and 14
- 4 – 24 V DC for coil 14

With negative logic:

- 1 – Unused
- 2 – 0 V for coil 12
- 3 – 24 V DC for coil 12 and 14
- 4 – 0 V for coil 14

Electrical Components

Valve Manifolds Type 44 VTSA, Type 45 VTSA-F – Metric Series

Fieldbus Connection/Control Block

All functions and features of the electrical peripherals CPX are permitted in connection with the CPX interface. This means:

- The valves and electrical outputs are supplied via the operating voltage connection of the CPX.
- The valves are supplied and switched independently via a separate port on the CPX.

Note

Further information can be found in www.festo.com/catalog/cpx

Electrical Multi-pin Plug Connection

The following multi-pin plug connection variants are offered for the valve manifold VTSA:

- Individual electrical connection M12 (5-pin M12 for 24 V DC): 6 or 10 M12 connectors allowing for 2 solenoids to be activated per connection.
- Sub-D multi-pin plug connection (37-pin for 24 V DC): A maximum of 32 solenoids can be

activated. The manifold is available with up to 32 single solenoid valves, 16 double solenoid valves, or a combination of up to 32 solenoids.

- Terminal box (cage clamp terminal strip for 24 V DC or 110 V AC): A maximum of 32 solenoids can be activated. The manifold is available with up to 32 single solenoid valves, 16 double solenoid valves, or a combination of up to 32 solenoids.

Each pin on the Sub-D multi-pin plug or terminal box can activate exactly a single solenoid coil. If the maximum configurable number of valve positions is 32, this means that 32 valves can be addressed via a single solenoid coil. With 16 or less valve positions, 2 valve solenoid coils per valve can be addressed.

Note

Use the following 37-pin connecting cables from Festo to connect the valve manifold with Sub-D multi-pin plug connection:

- NEBV-S1W37-...-LE10 for max. 8 solenoid coils
- NEBV-S1W37-...-LE26 for max. 22 solenoid coils
- NEBV-S1W37-...-LE37 for max. 32 solenoid coils
- NECV-S1W37 pre-assembled plug connector

Individual Electrical Connection, 6-way Code MP2, or 10-way Code MP3, 24 V DC

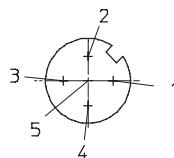
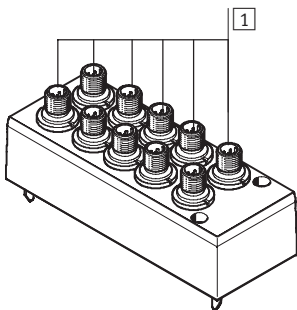

1 Connector plug M12x1, male, 5-pin

Pin allocation M12

- Pin1 – Unused
- Pin2 – 24 V DC for coil 12
- Pin3 – 0 V for coil 12 and 14
- Pin4 – 24 V DC for coil 14
- Pin5 – Functional earth

Electrical Components

Valve Manifolds Type 44 VTSA, Type 45 VTSA-F – Metric Series



Pin Allocation – Terminal Box (CageClamp), 24 V DC and 110 V AC; Electrical Connection Code T				
	Manifold	Coil/address	Manifold	Coil/address
<p>Each solenoid coil must be assigned to a specific terminal on the terminal strip in order for actuation of the valves to take place.</p>	1	0	17	16
	2	1	18	17
	3	2	19	18
	4	3	20	19
	5	4	21	20
	6	5	22	21
	7	6	23	22
	8	7	24	23
	9	8	25	24
	10	9	26	25
	11	10	27	26
	12	11	28	27
	13	12	29	28
	14	13	30	29
	15	14	31	30
	16	15	32	31
	<p>Note The drawing shows the view onto the terminal strip (CageClamp).</p>	Conductor		
33		0 V	35	0 V
34		0 V	36	0 V

1) 0 V for positive switching control signals; connect 24 V for negative switching control signals; mixed operation is not permitted.

Sub-D plug, 24 V DC; Electrical Connection Code MP1							
Type	Sheath	Length [m]	Wire x mm ² [mm ²]	Cable Ø [mm]	Part No.		
NEBV-S1W37-E2,5-LE10	Polyurethane (PUR)	2.5	10 x 0.34	7.7	539240		
NEBV-S1W37-E5-LE10		5			539241		
NEBV-S1W37-E10-LE10		10			539242		
NEBV-S1W37-E2,5-LE26		Polyvinyl chloride (PVC)	2.5	26 x 0.34	11.5	539243	
NEBV-S1W37-E5-LE26			5			539244	
NEBV-S1W37-E10-LE26			10			539245	
NEBV-S1W37-K2,5-LE37			Polyvinyl chloride (PVC)	2.5	37 x 0.34	13	539246
NEBV-S1W37-K5-LE37				5			539247
NEBV-S1W37-K10-LE37				10			539248
NEBV-S1W37-KM-2,5-LE10	Polyvinyl chloride (PVC)			2.5	10 x 0.34	7.7	543271
NEBV-S1W37-KM-5-LE10				5			543272
NEBV-S1W37-KM-10-LE10				10			543273
NEBV-S1W37-KM-2,5-LE27		Polyvinyl chloride (PVC)		2.5	27 x 0.34	11.5	543274
NEBV-S1W37-KM-5-LE27				5			543275
NEBV-S1W37-KM-10-LE27				10			543276
NEBV-S1W37-KM-2,5-LE37			Polyvinyl chloride (PVC)	2.5	37 x 0.34	13	543277
NEBV-S1W37-KM-5-LE37				5			543278
NEBV-S1W37-KM-10-LE37				10			543279

Electrical Components

Valve Manifolds Type 44 VTSA, Type 45 VTSA-F – Metric Series



Pin Allocation – Sub-D Plug Socket, 24 V DC; Electrical Connection Code MP1						
	Pin ²⁾	Address/coil	Core color ¹⁾	Pin ²⁾	Address/coil	Core color ¹⁾
	1	0	WH	17	16	WH PK
	2	1	BN	18	17	PK BN
	3	2	GN	19	18	WH BU
	4	3	YE	20	19	BN BU
	5	4	GY	21	20	WH RD
	6	5	PK	22	21	BN RD
	7	6	BU	23	22	GY GN
	8	7	RD	24	23	YE GY
	9	8	GY PK	25	24	PK GN
	10	9	RD BU	26	25	YE PK
	11	10	WH GN	27	26	GN BU
	12	11	BN GN	28	27	YE BU
	13	12	WH YE	29	28	GN RD
	14	13	YE BN	30	29	YE RD
	15	14	WH GY	31	30	GN BK
	16	15	GY BN	32	31	GY BU
Note The drawing shows the view onto the Sub-D plug socket at the multi-core cable NEBV-S1W37-....	Conductor					
	33	0 V ³⁾	YE BK	35	0 V ³⁾	BN BK
	34	0 V ³⁾	WH BK	36	0 V ³⁾	BK
	Earthing					
	37	FE (earth)	VT	–	–	–

- 1) To IEC 757
- 2) Pin 9 ... 35: Not available with cable NEBV-S1-W37-...-10
Pin 23 ... 33: Not available with cable NEBV-S1-W37-...-26
- 3) 0 V for positive switching control signals; connect 24 V for negative switching control signals; mixed operation is not permitted.

Dimensions⁴⁾

Download CAD Data → www.festo.com/us/cad

Multi-pin cable NEBV-S1W37-...

1 Cable conduit fitting M20x1.5

The wire colors refer to the following pre-assembled multi-core cables from Festo:

- NEBV-S1W37-...-10 for valve manifold with max. 8 solenoid coils
- NEBV-S1W37-...-26 for valve manifold with max. 22 solenoid coils
- NEBV-S1W37-...-37 for valve manifold with max. 32 solenoid coils

4) Dimensions are in millimeters, unless otherwise noted.

Electrical Components

Valve Manifolds Type 44 VTSA, Type 45 VTSA-F – Metric Series

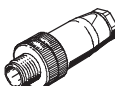
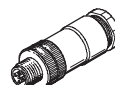
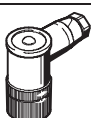
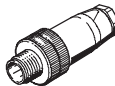
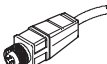
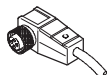
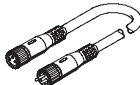

Electrical Connection Technology				
	Electrical connection	Type of mounting/cable length	Type	Part No.
Sensor plug/socket for inputs/outputs				
	Straight plug, 4-pin, screw manifold	Threaded connector M12	SEA-GS-7	18666
			SEA-GS-9	18778
			SEA-GS-11-DUO	18779
	Plug socket, angled, 4-pin, screw manifold	Union nut M12	SEA-M12-4WD-PG7	185498
	Straight plug, 4-pin, screw manifold	Threaded connector M12	SEA-4GS-7-2,5	192008
Plug socket with cable for connecting individual valves or sensors				
	Straight socket, 4-pin, M12	5 m	SIM-M12-4GD-5-PU	164259
	Angled socket, 4-pin, M12	5 m	SIM-M12-4WD-5-PU	164258
	Modular system for connecting cables	–	NEBU-... → www.festo.com/catalog/nebu	–

Installation and Operation

Valve Manifolds Type 44 VTSA, Type 45 VTSA-F – Metric Series

Valve Manifold Assembly

Sturdy manifold attachment thanks to:

- Four through-holes for wall mounting
- Additional mounting bracket
- H-rail mounting

Wall mounting

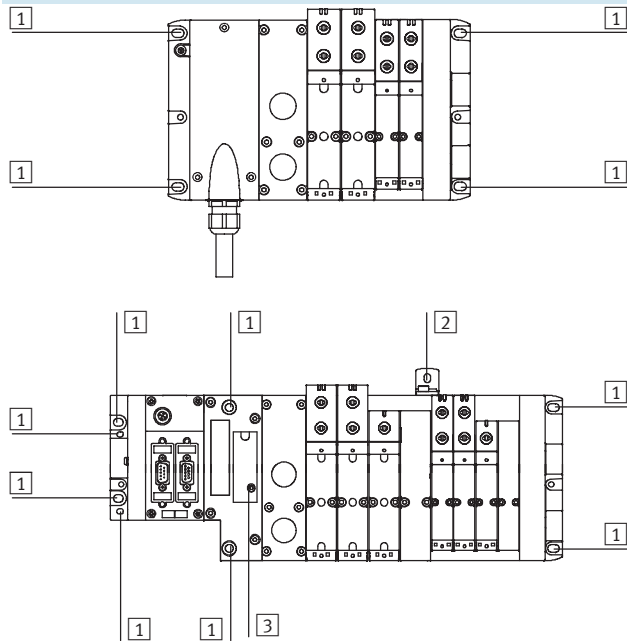

The VTSA/VTSA-F valve manifold is screwed onto the mounting surface using M6 screws. The mounting holes are located at the following points:

- Multi-pin plug (4 pieces):
2 each at the multi-pin connection block and the right-hand end plate
 - Fieldbus (4 pieces):
2 each at the left-hand (CPX) and right-hand (VTSA/VTSA-F) end plate.
- The pneumatic interface additionally provides further mounting holes as well as optional mounting brackets.

The fieldbus version additionally provides a bracket for wall mounting (Part No. 665983). The mounting brackets can be used with very long valve manifolds (6 manifold subbases or more) to improve load capacity during vibration or shocks.

- 1 Hole for M6 screw
- 2 Hole for M5 screw
- 3 Hole for DIN H-rail mounting

DIN H-rail mounting

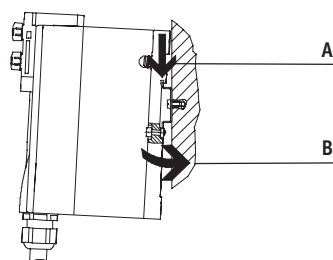

The VTSA/VTSA-F valve manifold is hooked onto the DIN H-rail (see arrow A). It is then swivelled about the DIN H-rail, then swung into place and secured with the clamping shim (see arrow B).

For DIN H-rail mounting of the valve manifold you will need the following VTSA/VTSA-F mounting kit:

- With multi-pin plug:
CPA-BG-NRH
- With fieldbus:
CPX-CPA-BG-NRH

This permits mounting of the valve manifold on a DIN H-rail to EN 60715.

Individual Valve Assembly

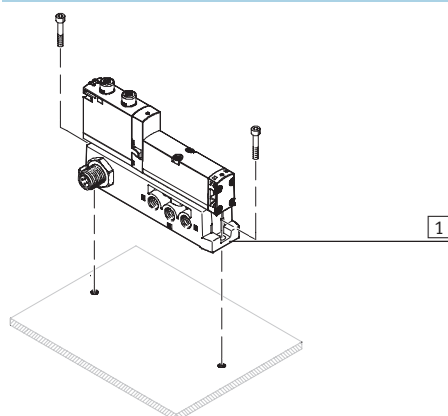

- 1 Vertical mounting holes

The individual manifold block is designed for wall mounting for integration into a system or machine. It is mounted vertically.

Installation and Operation

Valve Manifolds Type 44 VTSA, Type 45 VTSA-F – Metric Series

Display and Operation

Each solenoid coil is allocated an LED which indicates its switching status.

- Indicator 12 shows the switching status of the pilot control for output 2
- Indicator 14 shows the switching status of the pilot control for output 4

Manual override

The manual override allows the valve to be switched when in the electrically non-activated or de-energized status.

The valve is actuated by pushing the manual override. The set switching status can also be secured by turning the manual override.

Alternatives:

- A cover cap (accessory code N) can be fitted over the manual override to prevent it from being turned. The valve can then only be actuated by pressing it.
- A cover cap (accessory code V) can be fitted over the manual override to prevent it from being accidentally actuated.

Pneumatic connection and control elements

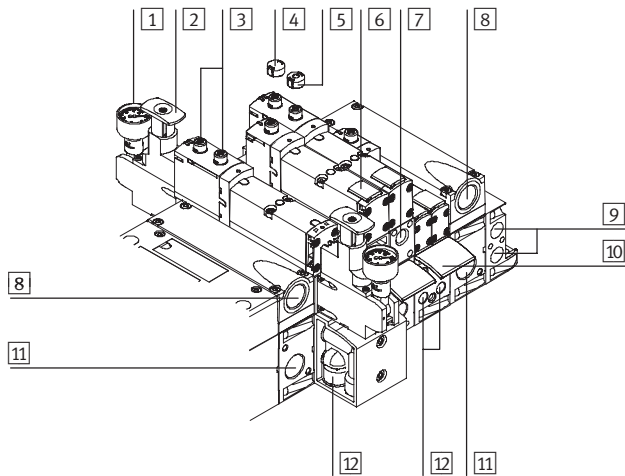

- | | |
|--|---|
| <ul style="list-style-type: none"> 1 Pressure gauge (optional) 2 Adjusting knob of optional pressure regulating plate 3 Manual override (for each pilot solenoid coil, pushing or pushing/detenting) 4 Optional cover cap for manual override (inhibits manual override) 5 Optional cover for manual override with non-detenting pushing function 6 Inscription label holder for valve 7 Adjusting screw of optional flow control plate 8 Exhaust ports (valves) (3/5) | <ul style="list-style-type: none"> 9 Pilot ports 12 and 14 for supplying the external pilot air supply 10 Inscription label holder for manifold block 11 Supply port 1 (operating pressure) 12 Working ports 2 and 4, for each valve position |
|--|---|

Note

A manually actuated valve (manual override) cannot be reset electrically. Conversely, an electrically actuated valve cannot be reset using the mechanical manual override.

Electrical connection and display components

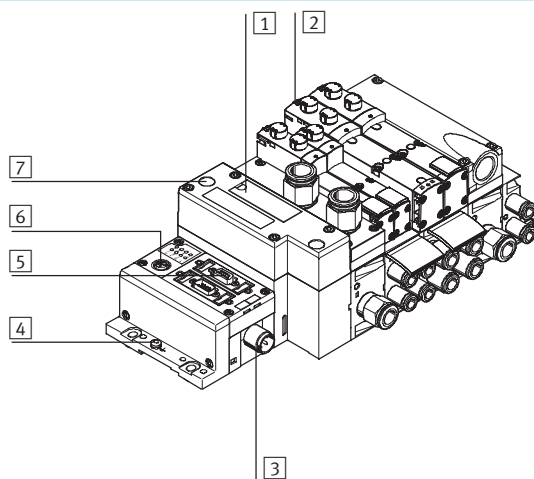

- 1 Inscription area and cover for DIN H-rail mounting
- 2 Yellow LEDs: Signal status display for pilot solenoid coils
- 3 Voltage supply connection
- 4 Earth manifold
- 5 Fieldbus connection (bus-specific)
- 6 Service interface for handheld unit, etc.
- 7 Red LED: Common fault display for valves

Installation and Operation

Valve Manifolds Type 44 VTSA, Type 45 VTSA-F – Metric Series



Manual Override (MO)

Manual override with automatic return (pushing)

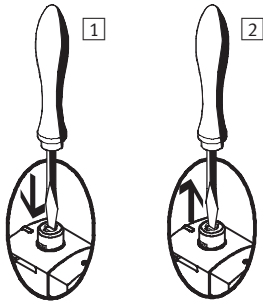

- 1 Press in the stem of the manual override using a pin or screwdriver. Valve is then actuated.
- 2 Remove the screwdriver. Spring force pushes the stem of the manual override back. Valve returns to the initial position (not with double solenoid valve code J).

Manual override set via turning (covered)

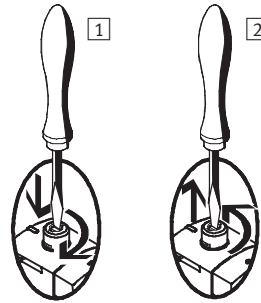

- 1 Press in the stem of the manual override using a pin or screwdriver until the valve switches and then turn the stem clockwise by 90° until the stop is reached. Valve remains actuated.
- 2 Turn the stem anti-clockwise by 90° until the stop is reached and then remove the screwdriver. Spring force pushes the stem of the manual override back. Valve returns to the initial position (not with double solenoid valve code J and D).

Inscription System

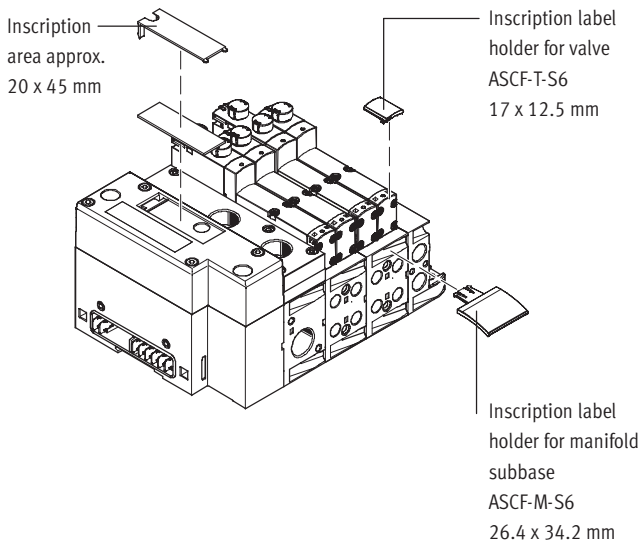

Inscription label holders can be applied to the valves and subbases to identify them. These inscription label holders can be ordered by entering the code B or T in the order code for accessories. Scope of delivery: Inscription label holder including inscription label. The following inscription labels can be used as spares:

- Inscription label holder for valve type ASCF-T-S6: Part No. 540888
 - Inscription label holder for manifold subbase type ASCF-M-S6: Part No. 540889
- Large inscription labels can be attached to the pneumatic interface as an alternative or in addition to the smaller labels.

Instructions for Use

Valve Manifolds Type 44 VTSA, Type 45 VTSA-F – Metric Series

Operate your equipment with unlubricated compressed air if possible. Festo valves and cylinders are designed for operation under normal use without any additional lubrication and still have a long service life.

The quality of compressed air downstream from the compressor must correspond to that of unlubricated compressed air. If possible, do not operate all of your equipment with lubricated compressed air. The lubricators should, where possible, always be installed directly upstream of the actuator used.

Unsuitable additional oil and an excessive oil content in the compressed air reduce the service life of the valve manifold.

Use Festo special oil OFSW-32 or the alternatives listed in the Festo catalog (as specified in DIN 51524 HLP32; basic oil viscosity 32 CST at 40 °C).

Bio-oils

When using bio-oils (oils which are based upon synthetic or native ester, e.g. rapeseed oil methyl ester), the maximum residual oil content of 0.1 mg/m³ must not be exceeded (see ISO 8573-1 Class 2).

Mineral oils

When using mineral oils (e.g. HLP oils to DIN 51524, parts 1 through 3) or similar oils based on poly-alpha-olefins (PAO), the maximum residual oil content of 5 mg/m³ must not be exceeded (see ISO 8573-1 Class 4).

A higher residual oil content irrespective of the compressor oil cannot be permitted, as the basic lubricant would be flushed out over time.

Technical Data

Valve Manifolds Type 44 VTSA, Type 45 VTSA-F – Metric Series

Flow rate

- Width 18 mm: Up to 700 l/min
- Width 26 mm: Up to 1,400 l/min
- Width 42 mm: Up to 1,500 l/min

Valve width

- 02: 18 mm
- 01: 26 mm
- 1: 42 mm

Voltage

- 24 V DC
- 110 V AC

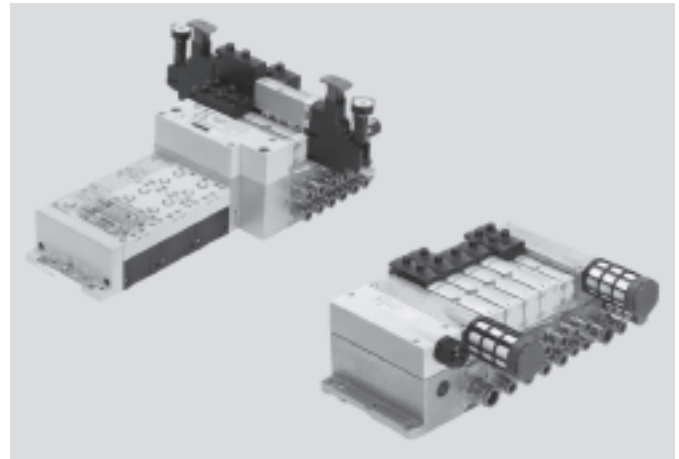

General Technical Data			
Width	18 mm	26 mm	42 mm (type 44 VTSA only)
Design	Electromagnetically actuated piston spool valve		
Lubrication	Lubrication for life		
Type of mounting	Wall mounting		
	On DIN H-rail to EN 60715		
Mounting position	Any		
Manual override	Pushing, pushing/detenting, covered		
Pneumatic connections	Threaded connection	Threaded connection	Threaded connection
Pneumatic connection	Via manifold subbase		
Supply port	1	G $\frac{1}{2}$, QS-G $\frac{1}{2}$ -12, QS-G $\frac{1}{2}$ -16	G $\frac{1}{2}$, QS-G $\frac{1}{2}$ -12, QS-G $\frac{1}{2}$ -16
Exhaust port	3/5	G $\frac{1}{2}$, QS-G $\frac{1}{2}$ -12, QS-G $\frac{1}{2}$ -16	G $\frac{1}{2}$, QS-G $\frac{1}{2}$ -12, QS-G $\frac{1}{2}$ -16
Working ports	2/4	G $\frac{1}{8}$, QS-G $\frac{1}{8}$ -6, QS-G $\frac{1}{8}$ -8	G $\frac{1}{4}$, QS-G $\frac{1}{4}$ -8, QS-G $\frac{1}{4}$ -10
Port for external pilot supply air	14	G $\frac{1}{4}$	G $\frac{1}{4}$
Pilot exhaust air port	12	G $\frac{1}{4}$	G $\frac{1}{4}$
Certification	CE		

Note: This product conforms with the ISO 1179-1 standard and the ISO 228-1 standard.

Technical Data

Valve Manifolds Type 44 VTSA, Type 45 VTSA-F – Metric Series

Standard Nominal Flow Rate [l/min] – Type 44 VTSA													
Valve function order code	M	O	J	D	N	K	H	B	G	E	P	Q	R
Width 18 mm													
Flow rate of valve	750				600			700 ¹⁾ 430 ²⁾		600			
Flow rate of valve on individual subbase	600				500			550 ¹⁾ 360 ²⁾		500			
Flow rate of valve on valve manifold	550				400			450 ¹⁾ 300 ²⁾		400			
Width 26 mm													
Flow rate of valve	1 400				1 250			1 400 ¹⁾ 1 000 ²⁾		1 250			
Flow rate of valve on individual subbase	1 200				1 100			1 200 ¹⁾ 850 ²⁾		1 000			
Flow rate of valve on valve manifold	1 100				900			1 000 ¹⁾ 700 ²⁾		900			
Width 42 mm													
Flow rate of valve	1 800				1 400			1 700 ¹⁾ 750 ²⁾		1 400			
Flow rate of valve on individual subbase	1 300				1 200			1 200 ¹⁾ 800 ²⁾		1 200			
Flow rate of valve on valve manifold	1 500				1 200			1 400 ¹⁾ 800 ²⁾		1 200			

1) Switching position

2) Mid-position

Standard Nominal Flow Rate [l/min] – Type 45 VTSA-F													
Valve function order code	M	O	J	D	N	K	H	B	G	E	P	Q	R
Width 18 mm													
Flow rate of valve	750				600			500 ¹⁾ 330 ²⁾		600			
Flow rate of valve on valve manifold	700				550			500 ¹⁾ 330 ²⁾		550			
Width 26 mm													
Flow rate of valve	1 400				1 250			1 400 ¹⁾ 700 ²⁾		1 250			
Flow rate of valve on valve manifold	1 350				1 150			1 350 ¹⁾ 700 ²⁾		1 150			

1) Switching position

2) Mid-position

Technical Data

Valve Manifolds Type 44 VTSA, Type 45 VTSA-F – Metric Series



Operating and Environmental Conditions			M	O	J	D	N	K	H	B	G	E	P	Q	R
Valve function order code															
Operating medium			Filtered compressed air, lubricated or unlubricated, inert gases												
Grade of filtration			[μm]	40 (average pore size)											
Operating pressure	Pilot pressure	[bar]	3 ... 10												
	With internal pilot air	[bar]	3 ... 10												
	With external pilot air	[bar]	-0.9 ... +10				3 ... 10				-0.9 ... +10				
Ambient temperature			[$^{\circ}\text{C}$]	-5 ... +50											
Temperature of medium			[$^{\circ}\text{C}$]	-5 ... +50											
Storage temperature ¹⁾			[$^{\circ}\text{C}$]	-20 ... +40											
Relative air humidity			[%]	90											

1) Long-term storage

Pilot Pressure p12/14 as a Function of Operating Pressure p1

For 3/2-way valves

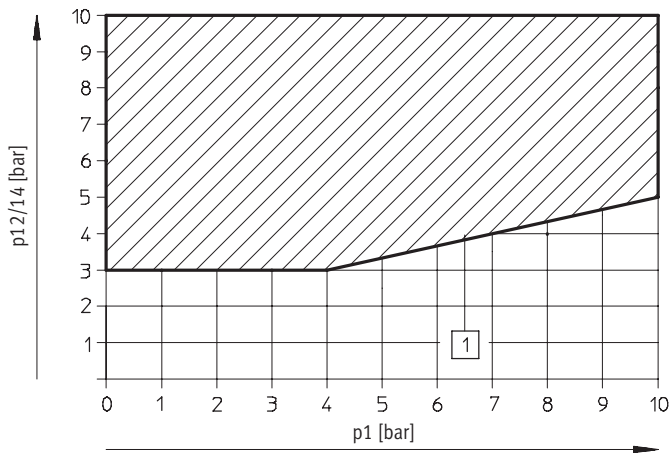

1) Operating range for valves with external pilot air supply

Valve Response Times [ms]		M	O	J	D	N	K	H	B	G	E	P	Q	R
18 mm														
Response times	on	22	12	–	–	12	12	12	15	15	15	25	25	25
	off	28	38	–	–	30	30	30	44	44	44	12	12	12
	changeover	–	–	11	11	–	–	–	22	22	22	–	–	–
26 mm														
Response times	on	25	20	–	–	20	20	20	22	22	22	32	32	32
	off	45	65	–	–	38	38	38	65	65	65	30	30	30
	changeover	–	–	18	18	–	–	–	33	33	33	–	–	–
42 mm (type 44 VTSA only)														
Response times	on	27	22	–	–	20	20	20	22	22	22	34	34	34
	off	45	60	–	–	38	38	38	65	65	65	28	28	28
	changeover	–	–	16	16	–	–	–	–	–	–	–	–	–

Technical Data

Valve Manifolds Type 44 VTSA, Type 45 VTSA-F – Metric Series



Flow Rate q_n as a Function of Output Pressure p_2 with Pressure Regulator Plates (P Regulator Plate) for Port 1

Width 18 mm

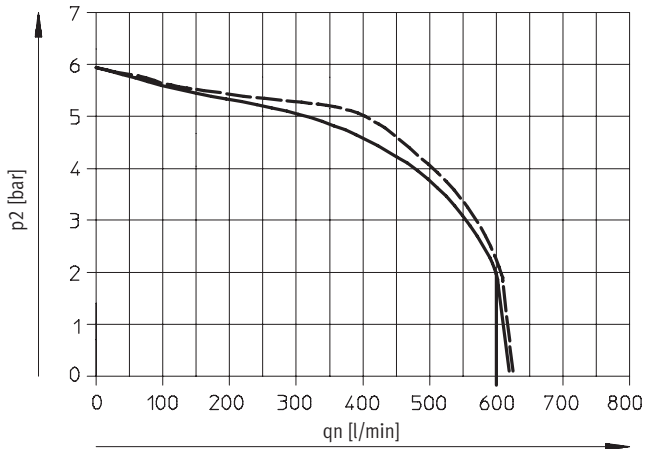

--- 6 bar
— 10 bar

Width 26 mm

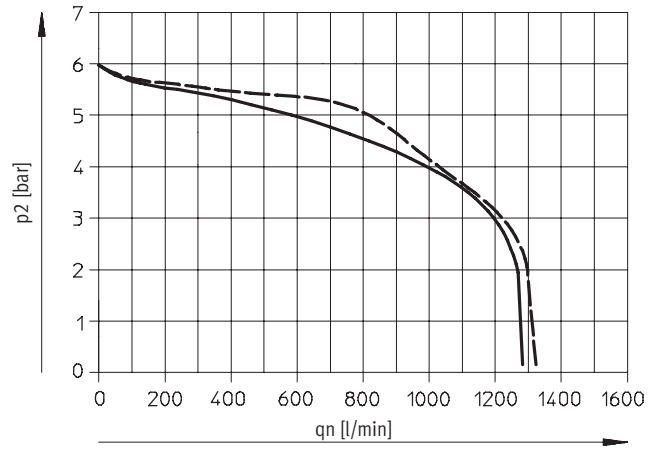

--- 6 bar
— 10 bar

Flow Rate q_n as a Function of Output Pressure p_2 with Pressure Regulator Plates (AB Regulator Plates) for Port 2, 4 or Ports 4/2

Width 18 mm

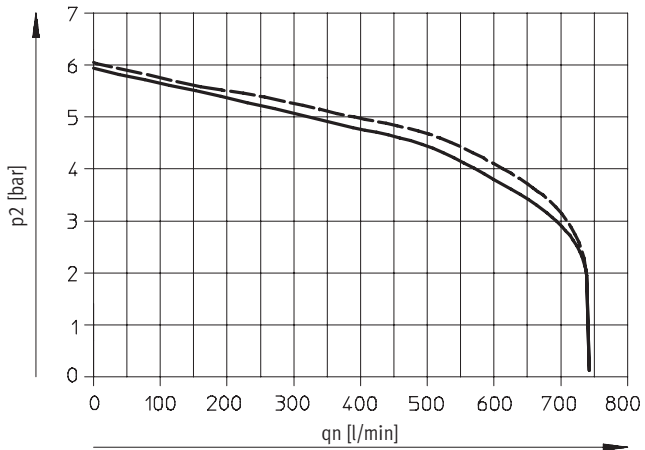

--- 6 bar
— 10 bar

Width 26 mm

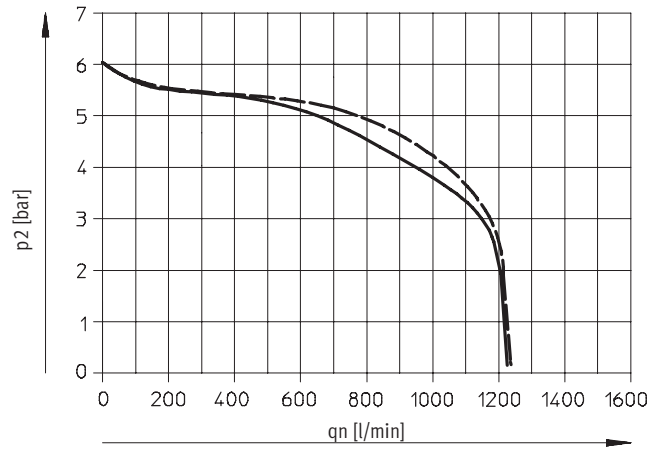

--- 6 bar
— 10 bar

Technical Data

Valve Manifolds Type 44 VTSA, Type 45 VTSA-F – Metric Series



Flow Rate q_n as a Function of Output Pressure p_2 with Pressure Regulator Plates (AB Regulator Plates, Rev.) for Ports 4/2, Reversible

Width 18 mm

Width 26 mm

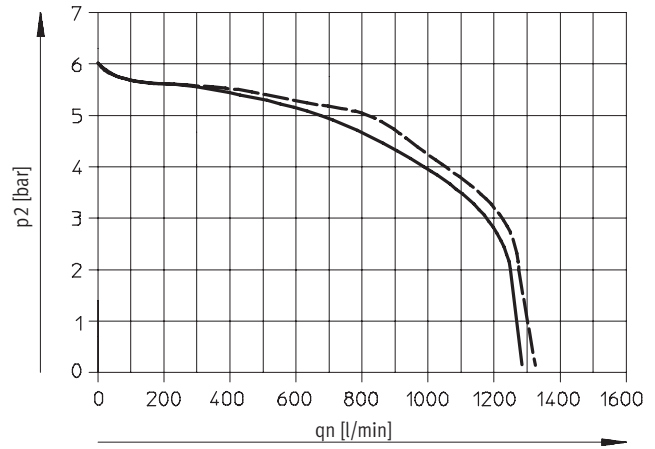
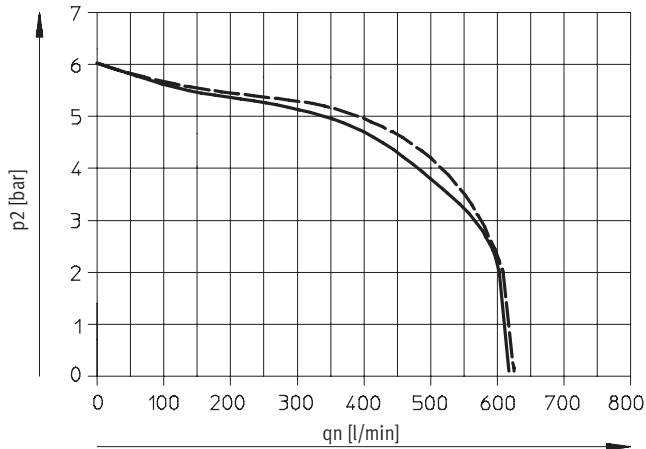

--- 6 bar
— 10 bar

--- 6 bar
— 10 bar

Flow Rate q_n as a Function of Flow Control

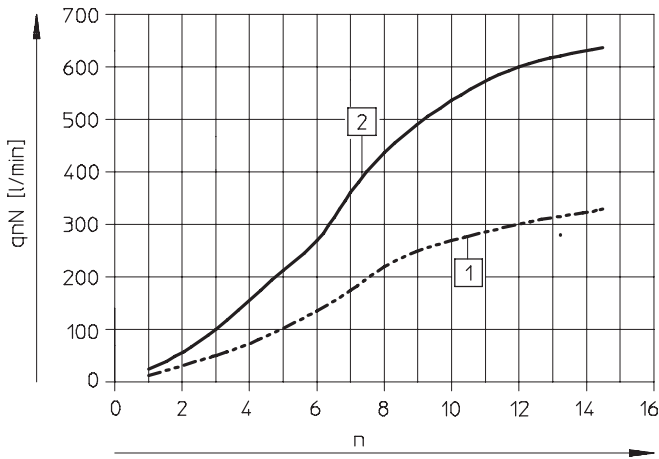

1 Width 18 mm
2 Width 26 mm
n Revolutions of the adjusting screw

Technical Data

Valve Manifolds Type 44 VTSA, Type 45 VTSA-F – Metric Series

Electrical Data – VTSA/VTSA-F with CPX Manifold			
	18 mm	26 mm	42 mm (type 44 only)
Voltage supply for electronics/sensors (pin 1)			
Operating voltage	[V]	24 DC ±10%	
Steady state current consumption at 24 V DC	[mA]	20	
Duty cycle		100%	
Load voltage supply for valves (pin 2)			
Operating voltage	[V]	24 DC ±10%	
Diagnostic message undervoltage V_{OFF} load voltage outside function range	[V]	21.6 ... 21.5	
Protection class to EN 60529		IP65 (for all types of signal transmission in assembled state)	
Power consumption at 24 V DC			
2x 3/2-way valve	[W]	1.3	
5/2-way valve, 5/3-way valve	[W]	1.6	

Electrical Data – VTSA/VTSA-F with Multi-pin Plug Connection			
	18 mm	26 mm	42 mm
Load voltage supply for valves			
Operating voltage	[V]	24 DC ±10% 110 AC ±10% (50 ... 60 Hz)	
Duty cycle		100%	
Protection class to EN 60529		IP65 (for all types of signal transmission in assembled state), NEMA 4	
Power consumption at 24 V DC			
2x 3/2-way valve	[W]	1.3	
5/2-way valve, 5/3-way valve	[W]	1.6	
Power consumption at 110 V AC			
2x 3/2-way valve	[VA]	1	
5/2-way valve, 5/3-way valve	[VA]	1.6	

Technical Data

Valve Manifolds Type 44 VTSA, Type 45 VTSA-F – Metric Series

FESTO

Materials			
	18 mm	26 mm	42 mm
Manifold subbase	Die-cast aluminum		
Valve	Die-cast aluminum, reinforced polyamide		
Seals	Nitrile rubber, elastomer (support made of steel)		
Supply plate	Die-cast aluminum		
Right-hand end plate	Die-cast aluminum		
Left-hand pneumatic interface	Die-cast aluminum		
Flow control plate	Die-cast aluminum		
Pressure regulator plate	Die-cast aluminum, reinforced polyamide		
Multi-pin connection block	Die-cast aluminum		
Cover for the pneumatic interface and multi-pin plug connection	Wellamid, reinforced polyamide		

Product Weight [g]			
	18 mm	26 mm	42 mm (type 44 only)
Sub-D multi-pin interface module or manifold strip ¹⁾	550		
Interface module CPX ¹⁾	1,470		
Supply plate ²⁾			
• Exhaust plate with 3 and 5 common	617		
• Exhaust port cover with 3 and 5 separated	597		
Right-hand end plate ³⁾			
• Axial	339		
• Selector	281		
Manifold subbase ⁴⁾	447	634	340
90° connection plate ³⁾	170	230	176
Pressure regulator plate			
for port 1	350	402	640
for port 4 or 2	367	448	640
for ports 4/2	611	692	920
Flow control plate	228	320	220
Vertical supply plate ³⁾	140	191	340
Vertical shut-off plate	209	273	600
Valves			
• 5/3-way valve (code B, G, E)	191	320	456
• 5/2-way valve, single solenoid (code M, O)	163	293	426
• 5/2-way valve, double solenoid (code J, D)	172	276	439
• 2x 3/2-way valve (code N, K, H, P, Q, R)	190	335	442
Blanking plate	34.4	73.3	68

1) With thin metal seal, printed circuit board

2) With thin metal seal and electrical manifold module

3) With screws

4) With thin metal seal, electrical manifold module, inscription label holder, 4 screws

Dimensional Drawings

Valve Manifolds Type 44 VTSA – Metric Series

Dimensions¹⁾

Download CAD Data → www.festo.com/us/cad

Individual subbase with M12 plug, width 18 mm

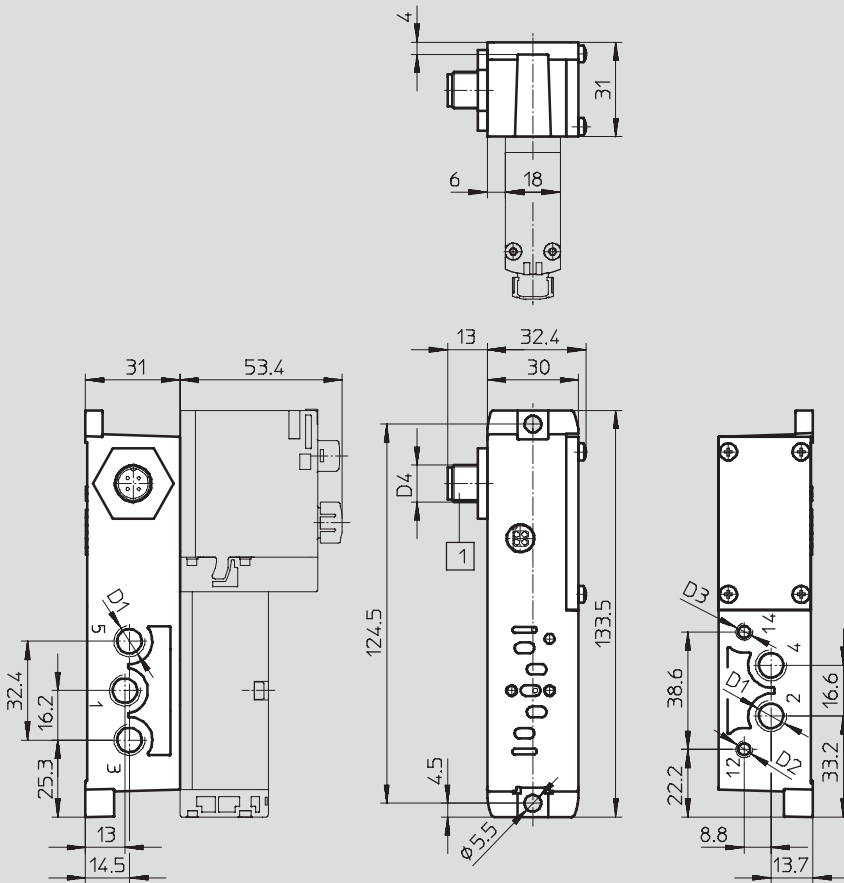

1) Plug to EN 61076-2-101

Type	D1	D2	D3	D4
External pilot air supply, M12 plug				
VABS-S4-2S-G18-R3	G $\frac{1}{8}$	M5	M5	M12
Internal pilot air supply, M12 plug				
VABS-S4-2S-G18-B-R3	G $\frac{1}{8}$	M5	-	M12

1) Dimensions are in millimeters, unless otherwise noted.

Note: This product conforms with the ISO 1179-1 standard and the ISO 228-1 standard.

Dimensional Drawings

Valve Manifolds Type 44 VTSA – Metric Series



Dimensions¹⁾

Download CAD Data → www.festo.com/us/cad

Individual subbase with cable manifolds, width 18 mm

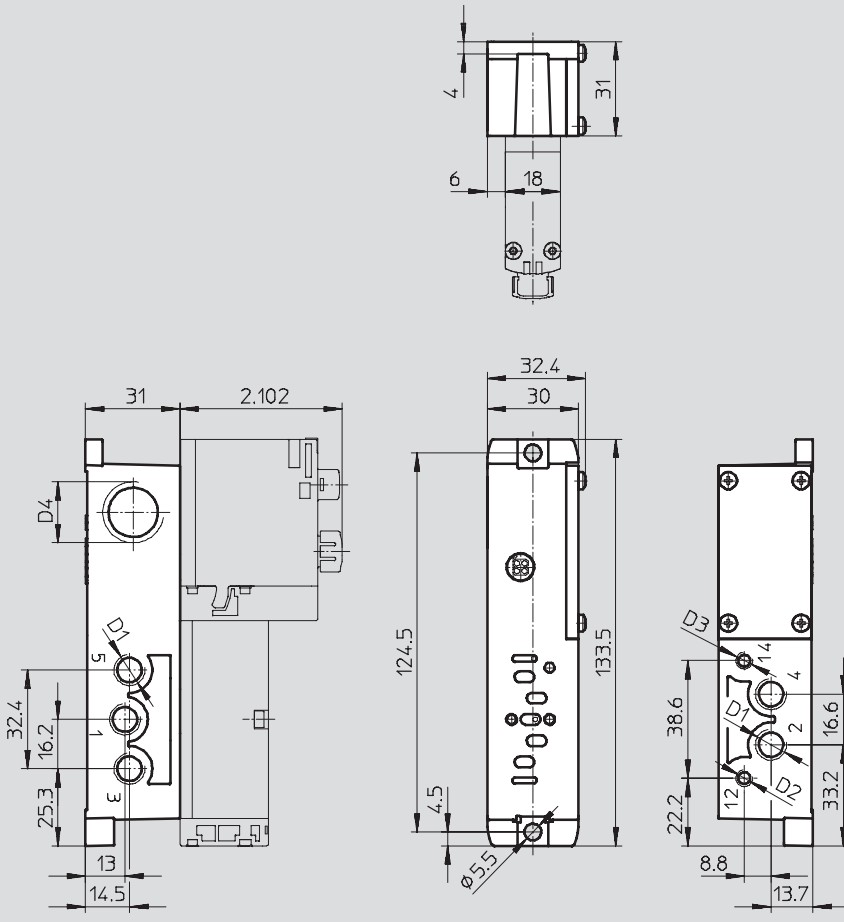

Type	D1	D2	D3	D4
External pilot air supply, cable manifolds				
VABS-S4-2S-G18-K2	G1/8	M5	M5	M20x1.5
Internal pilot air supply, cable manifolds				
VABS-S4-2S-G18-B-K2	G1/8	M5	–	M20x1.5

1) Dimensions are in millimeters, unless otherwise noted.

Note: This product conforms with the ISO 1179-1 standard and the ISO 228-1 standard.

Dimensional Drawings

Valve Manifolds Type 44 VTSA – Metric Series

Dimensions¹⁾

Download CAD Data → www.festo.com/us/cad

Individual subbase with M12 plug, width 26 mm

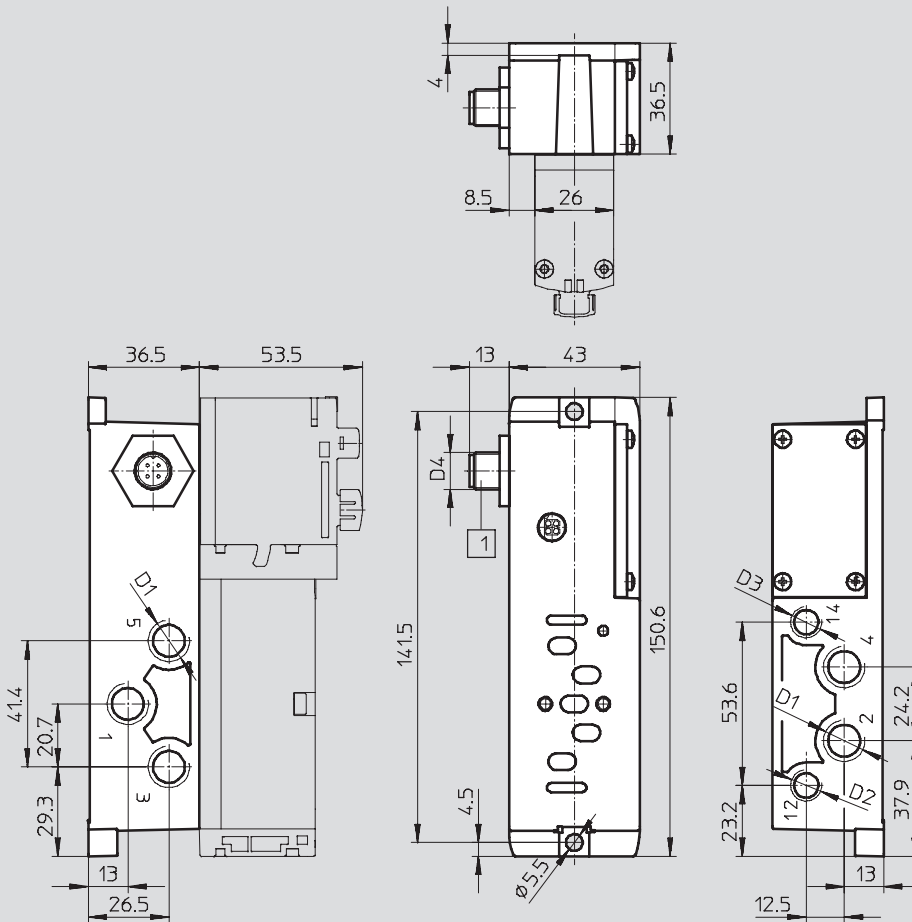

1) Plug to EN 61076-2-101

Type	D1	D2	D3	D4
External pilot air supply, M12 plug				
VABS-S4-1S-G14-R3	G1/4	G1/8	G1/8	M12
Internal pilot air supply, M12 plug				
VABS-S4-1S-G14-B-R3	G1/4	G1/8	-	M12

1) Dimensions are in millimeters, unless otherwise noted.

Note: This product conforms with the ISO 1179-1 standard and the ISO 228-1 standard.

Dimensional Drawings

Valve Manifolds Type 44 VTSA – Metric Series



Dimensions¹⁾

Download CAD Data → www.festo.com/us/cad

Individual subbase with cable manifolds, width 26 mm

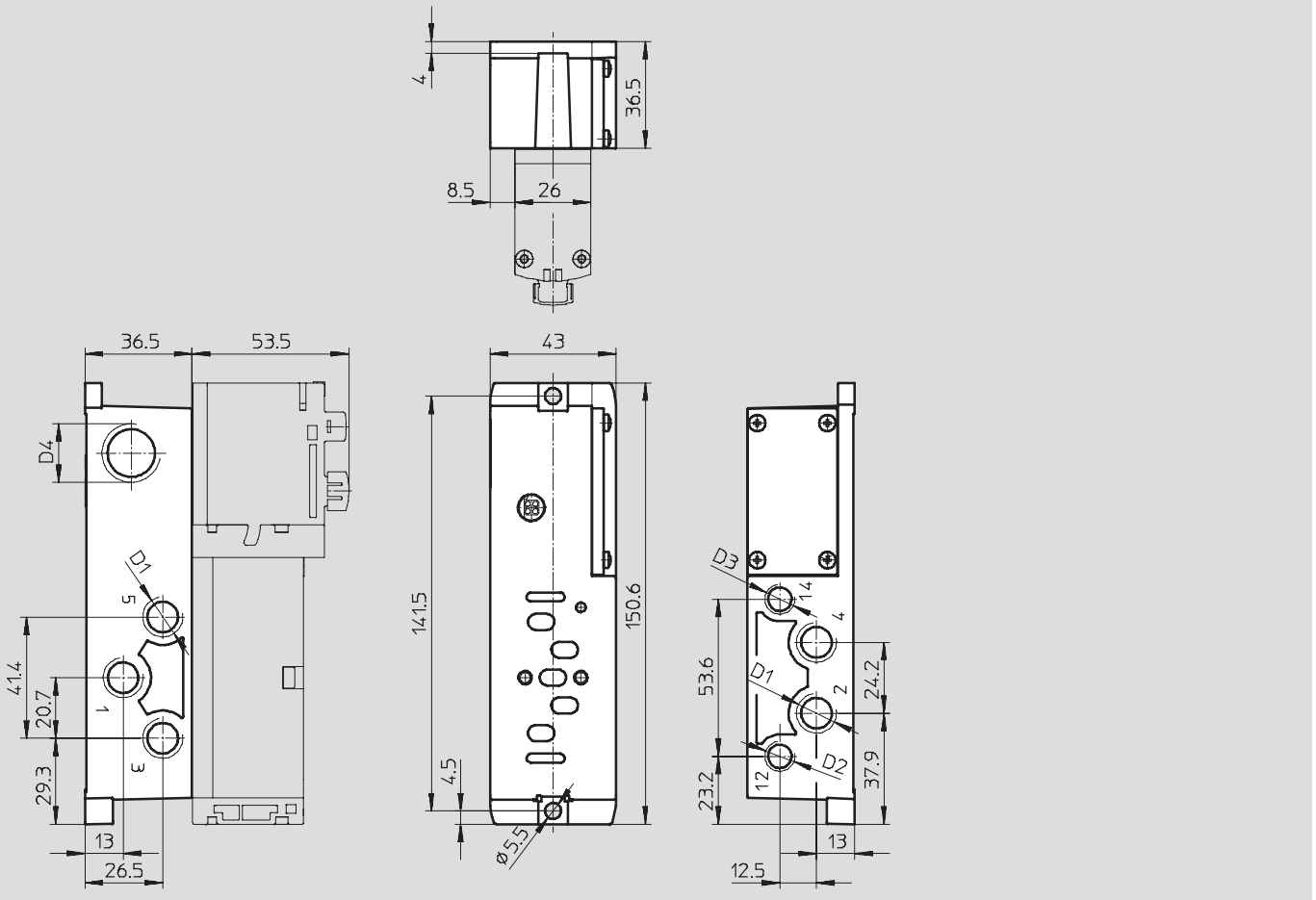

Type	D1	D2	D3	D4
External pilot air supply, cable manifolds				
VABS-S4-1S-G14-K2	G $\frac{1}{4}$	G $\frac{1}{8}$	G $\frac{1}{8}$	M20x1.5
Internal pilot air supply, cable manifolds				
VABS-S4-1S-G14-B-K2	G $\frac{1}{4}$	G $\frac{1}{8}$	-	M20x1.5

1) Dimensions are in millimeters, unless otherwise noted.

Note: This product conforms with the ISO 1179-1 standard and the ISO 228-1 standard.

Dimensional Drawings

Valve Manifolds Type 44 VTSA – Metric Series

Dimensions¹⁾

Download CAD Data → www.festo.com/us/cad

Individual subbase with spring-loaded manifold (C1) or for self-assembly (K1), width 42 mm

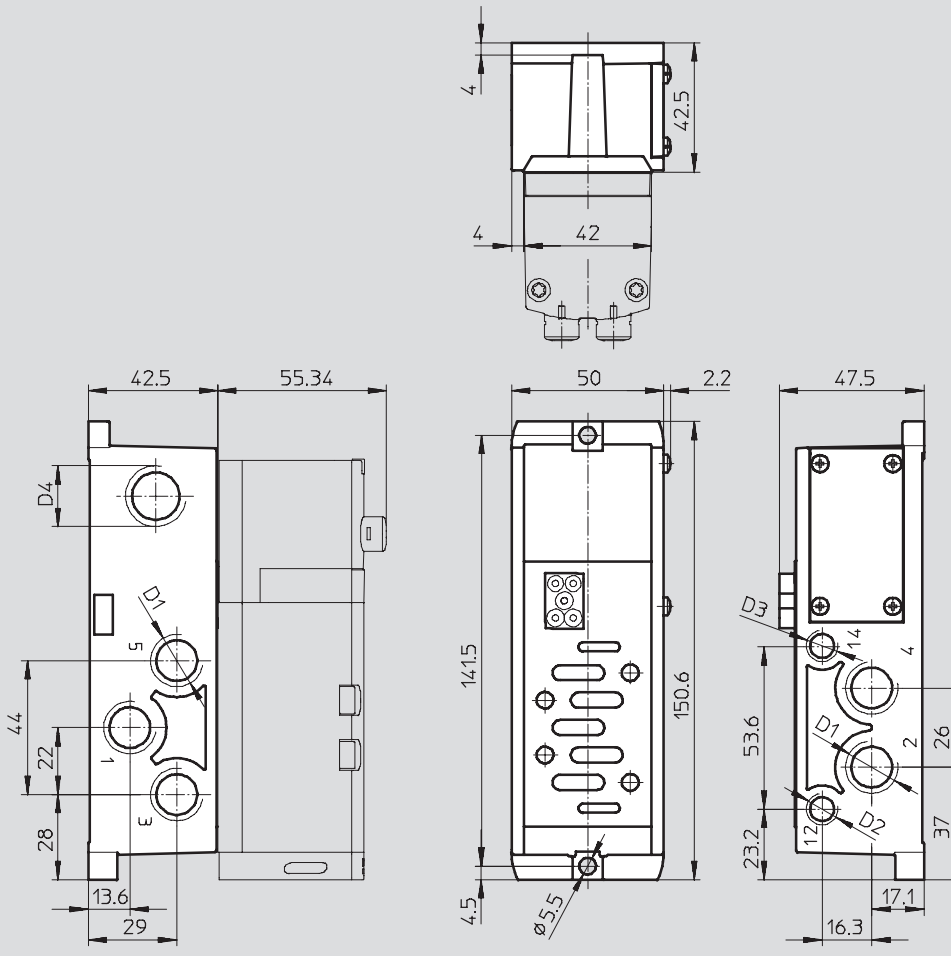

Type	D1	D2	D3	D4
External pilot air supply				
VABS-S2-1S-G38-K1(C1)	G3/8	G1/8	G1/8	M20x1.5
Internal pilot air supply				
VABS-S2-1S-G14-B-K1(C1)	G3/8	G1/8	-	M20x1.5

1) Dimensions are in millimeters, unless otherwise noted.

Note: This product conforms with the ISO 1179-1 standard and the ISO 228-1 standard.

Dimensional Drawings

Valve Manifolds Type 44 VTSA – Metric Series

Dimensions¹⁾

Download CAD Data → www.festo.com/us/cad

Individual subbase with M12 plug, width 42 mm

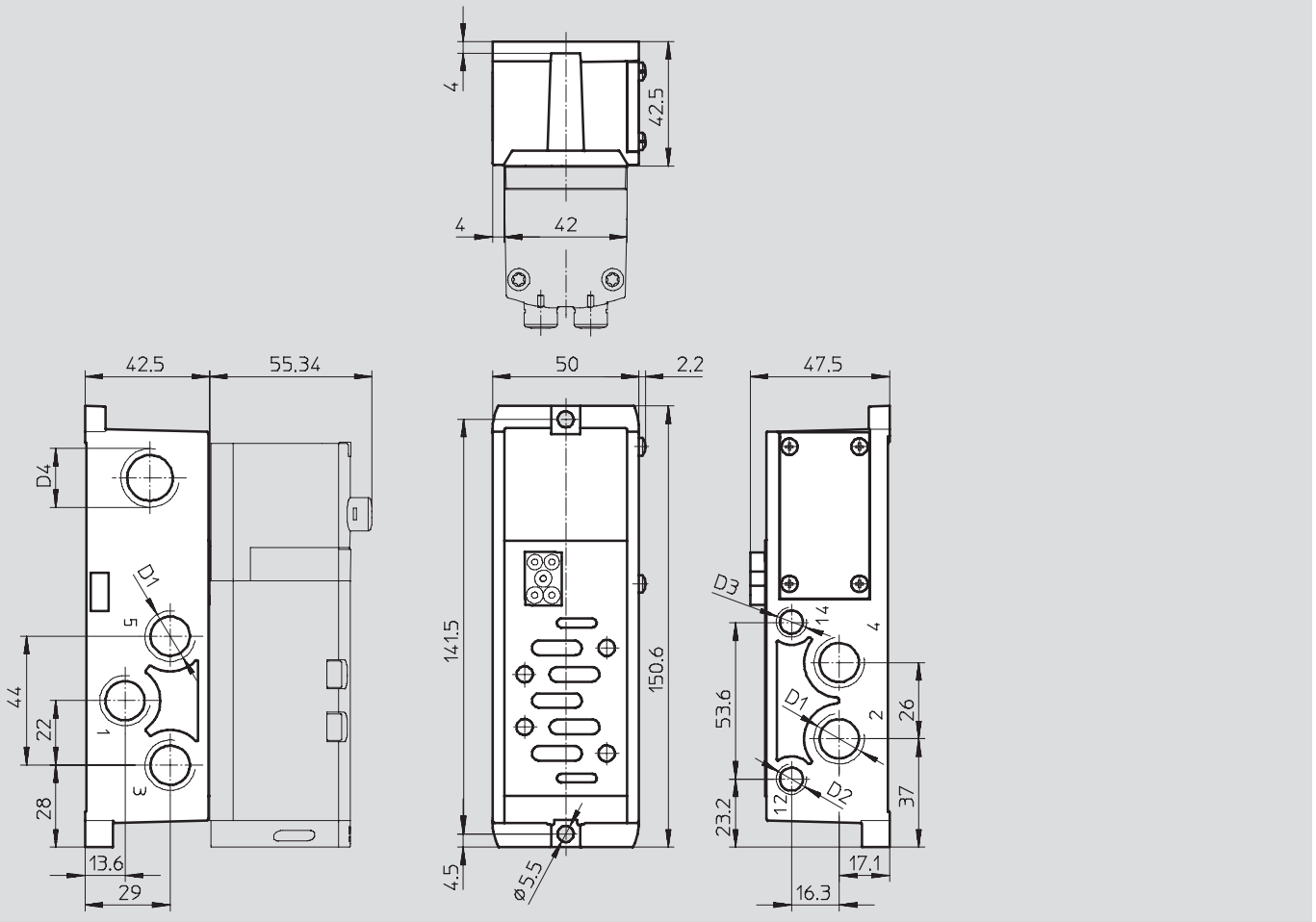

Type	D1	D2	D3	D4
External pilot air supply				
VABS-S2-1S-G38-R3	G3/8	G1/8	G1/8	M20x1.5
Internal pilot air supply				
VABS-S2-1S-G14-B-R3	G3/8	G1/8	–	M20x1.5

1) Dimensions are in millimeters, unless otherwise noted.

Note: This product conforms with the ISO 1179-1 standard and the ISO 228-1 standard.

Dimensional Drawings

Valve Manifolds Type 44 VTSA – Metric Series



Dimensions¹⁾

Download CAD Data → www.festo.com/us/cad

Valve manifold with individual electrical connection

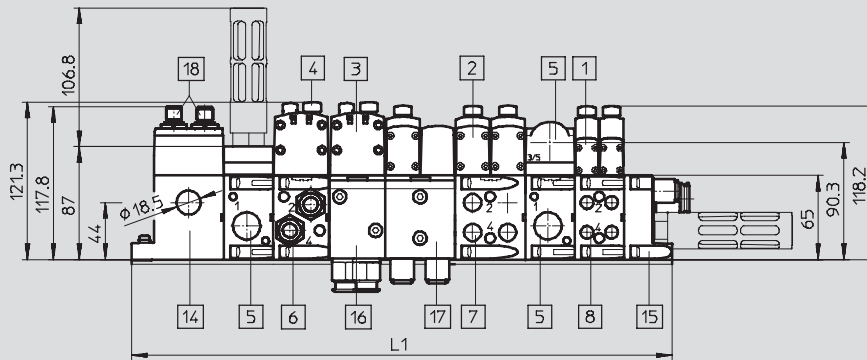
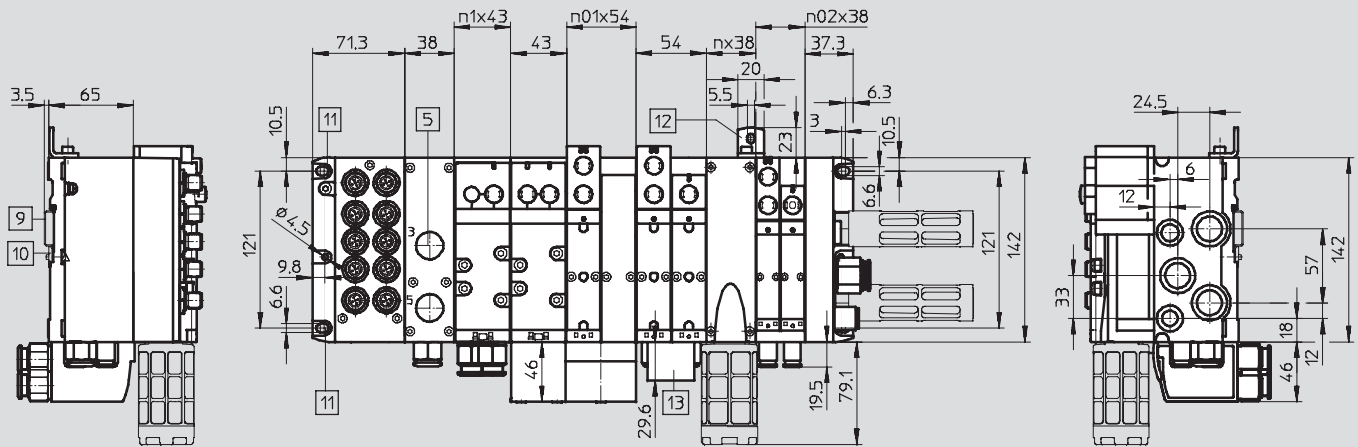

- | | | | |
|---------------------------------------|---------------------------------------|---|---|
| 1 Solenoid valve 18 mm | 7 Threaded connection G $\frac{1}{4}$ | 13 Inscription label holder | n02 Number of manifold subbases 18 mm |
| 2 Solenoid valve 26 mm | 8 Threaded connection G $\frac{1}{8}$ | 14 Individual connection | n01 Number of manifold subbases 26 mm |
| 3 Solenoid valve 42 mm | 9 DIN H-rail | 15 End plate | n1 Number of manifold subbases 42 mm |
| 4 Cover cap/manual override | 10 DIN H-rail mounting kit | 16 90° connection plate width 42 mm, G $\frac{3}{8}$ | n Number of supply plates (only with end plate with pilot air selector) |
| 5 Threaded connection G $\frac{1}{2}$ | 11 Mounting hole | 17 90° connection plate width 18 mm, G $\frac{1}{8}$ width 26 mm, G $\frac{1}{4}$ | |
| 6 Threaded connection G $\frac{3}{8}$ | 12 Additional mounting bracket | 18 M12 plug, 5-pin (6-way or 10-way) | |

Width	L1
18 mm	$71.3 + n02 \times 38 + n \times 38 + 37.3$
26 mm	$71.3 + n01 \times 54 + n \times 38 + 37.3$
42 mm	$71.3 + n1 \times 43 + n \times 38 + 37.3$
Mixture of 18 mm, 26 mm and 42 mm	$71.3 + n02 \times 38 + n01 \times 54 + n1 \times 43 + n \times 38 + 37.3$

1) Dimensions are in millimeters, unless otherwise noted.

Dimensional Drawings

Valve Manifolds Type 44 VTSA – Metric Series



Dimensions¹⁾

Download CAD Data → www.festo.com/us/cad

Valve manifold with multi-pin plug connection

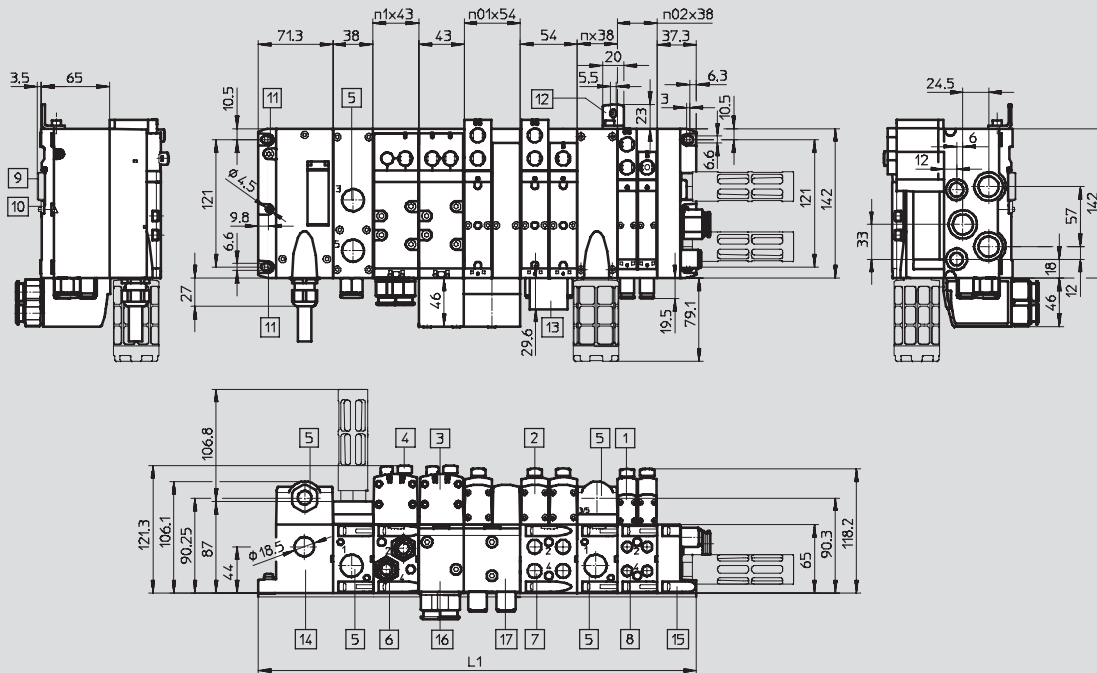

- | | | | |
|-----------------------------|---------------------------------------|---|---------------------------------------|
| 1 Solenoid valve 18 mm | 5 Threaded connection G $\frac{1}{2}$ | 11 Mounting hole | n02 Number of manifold subbases 18 mm |
| 2 Solenoid valve 26 mm | 6 Threaded connection G $\frac{3}{8}$ | 12 Additional mounting bracket | n01 Number of manifold subbases 26 mm |
| 3 Solenoid valve 42 mm | 7 Threaded connection G $\frac{1}{4}$ | 13 Inscription label holder | n1 Number of manifold subbases 42 mm |
| 4 Cover cap/manual override | 8 Threaded connection G $\frac{1}{8}$ | 14 Multi-pin plug connection | n Number of supply plates |
| 9 DIN H-rail | 9 DIN H-rail mounting kit | 15 End plate | |
| 10 DIN H-rail mounting kit | | 16 90° connection plate width 42 mm, G $\frac{3}{8}$ | |
| | | 17 90° connection plate width 18 mm, G $\frac{1}{8}$ width 26 mm, G $\frac{1}{4}$ | |

Width	L1
18 mm	$71.3 + n02 \times 38 + n \times 38 + 37.3$
26 mm	$71.3 + n01 \times 54 + n \times 38 + 37.3$
42 mm	$71.3 + n1 \times 43 + n \times 38 + 37.3$
Mixture of 18 mm, 26 mm and 42 mm	$71.3 + n02 \times 38 + n01 \times 54 + n1 \times 43 + n \times 38 + 37.3$

Supply plate with silencer

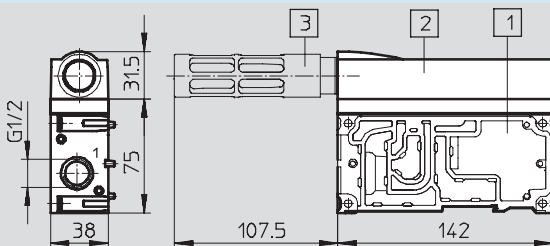

- | |
|--------------------------------|
| 1 Supply plate |
| 2 Exhaust port cover |
| 3 Silencer U- $\frac{1}{2}$ -B |

1) Dimensions are in millimeters, unless otherwise noted.

Dimensional Drawings

Valve Manifolds Type 44 VTSA – Metric Series

Dimensions¹⁾ Download CAD Data → www.festo.com/us/cad

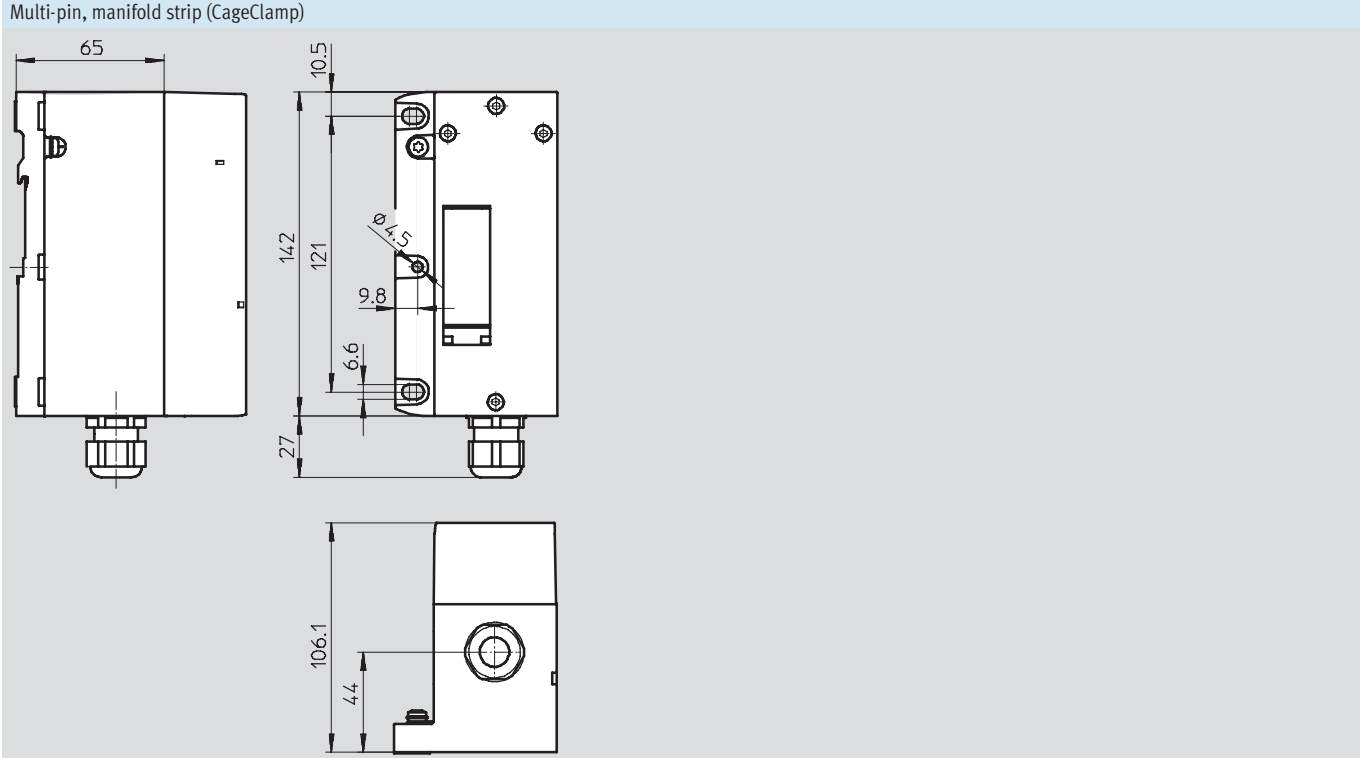

1) Dimensions are in millimeters, unless otherwise noted.

Dimensional Drawings

Valve Manifolds Type 44 VTSA – Metric Series



Dimensions¹⁾

Download CAD Data → www.festo.com/us/cad

Valve manifold with fieldbus connection

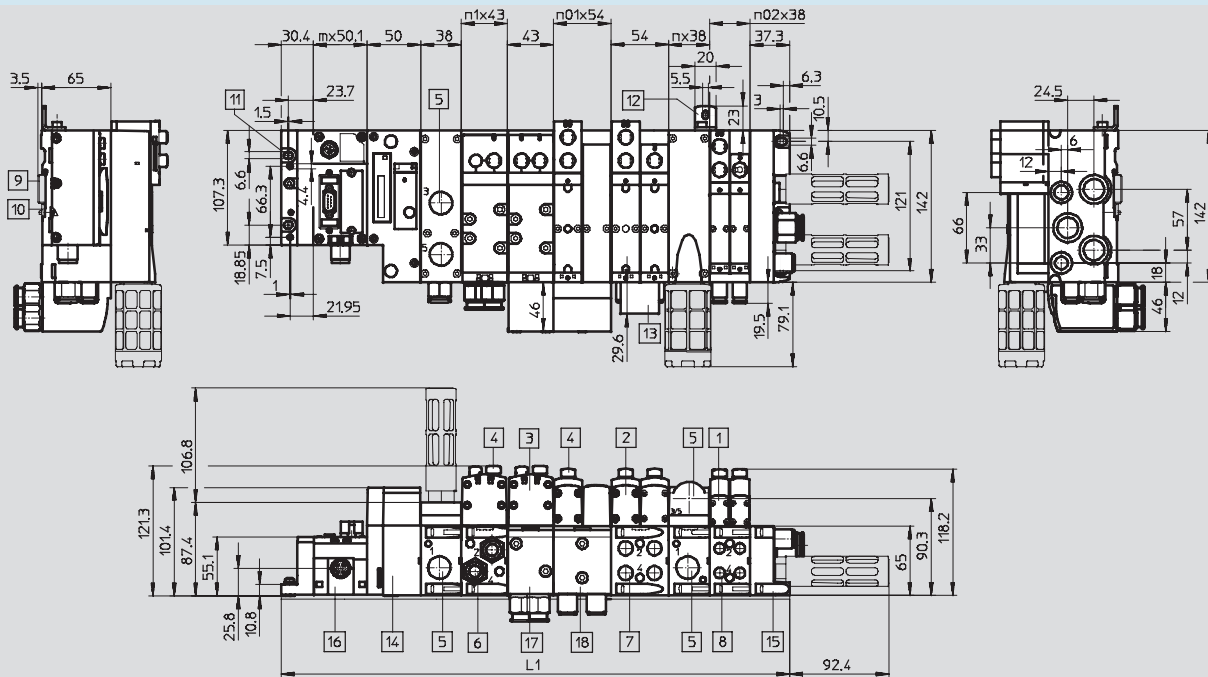

- | | | | |
|---------------------------------------|---------------------------------------|--|---|
| 1 Solenoid valve 18 mm | 7 Threaded connection G $\frac{1}{4}$ | 14 Pneumatic interface CPX | n02 Number of manifold subbases 18 mm |
| 2 Solenoid valve 26 mm | 8 Threaded connection G $\frac{1}{8}$ | 15 End plate | n01 Number of manifold subbases 26 mm |
| 3 Solenoid valve 42 mm | 9 DIN H-rail | 16 CPX module/fieldbus node | n1 Number of manifold subbases 42 mm |
| 4 Cover cap/manual override | 10 DIN H-rail mounting kit | 17 90° connection plate width 42 mm, G $\frac{3}{8}$ | n Number of supply plates (only with end plate with pilot air selector) |
| 5 Threaded connection G $\frac{1}{2}$ | 11 Mounting hole | 18 90° connection plate width 18 mm, G $\frac{1}{8}$ | m Number of CPX modules |
| 6 Threaded connection G $\frac{3}{8}$ | 12 Additional mounting bracket | | |
| | 13 Inscription label holder | | |

Width	L1
18 mm	$30.4 + m \times 50.1 + 50 + n02 \times 38 + n \times 38 + 37.3$
26 mm	$30.4 + m \times 50.1 + 50 + n01 \times 54 + n \times 38 + 37.3$
42 mm	$30.4 + m \times 50.1 + 50 + n1 \times 43 + n \times 38 + 37.3$
Mixture of 18 mm, 26 mm and 42 mm	$30.4 + m \times 50.1 + 50 + n02 \times 38 + n01 \times 54 + n1 \times 43 + n \times 38 + 37.3$

Supply plate with silencer

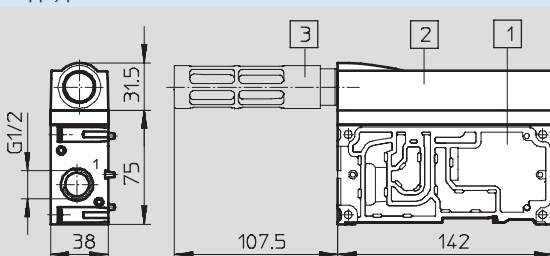

- | |
|--------------------------------|
| 1 Supply plate |
| 2 Exhaust port cover |
| 3 Silencer U- $\frac{1}{2}$ -B |

1) Dimensions are in millimeters, unless otherwise noted.

Dimensional Drawings

Valve Manifolds Type 44 VTSA – Metric Series

Dimensions¹⁾

Download CAD Data → www.festo.com/us/cad

Vertical stacking components, width 18 mm

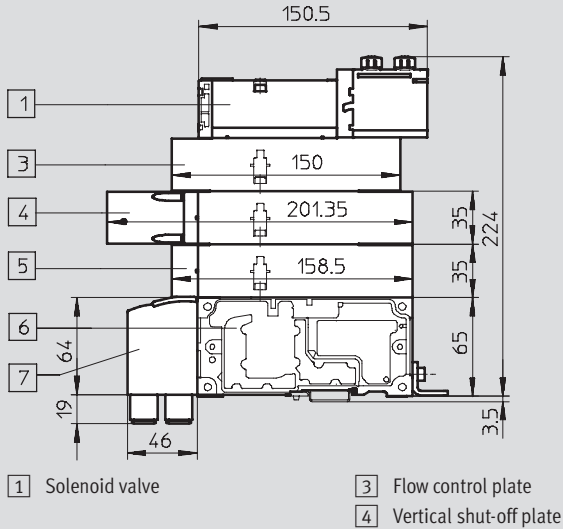

- 1 Solenoid valve
- 3 Flow control plate
- 5 Vertical supply plate
- 7 90° connection plate
- 4 Vertical shut-off plate
- 6 Manifold subbase

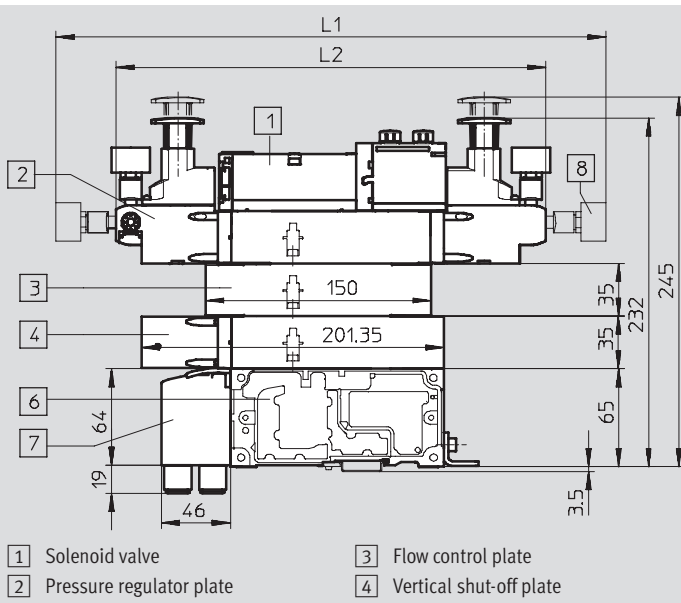

- 1 Solenoid valve
- 2 Pressure regulator plate
- 3 Flow control plate
- 4 Vertical shut-off plate
- 6 Manifold subbase
- 7 90° connection plate
- 8 Pressure gauge, freely positionable

Width	L1	L2
18 mm	348.2	268.6
26 mm	365.7	286.1

1) Dimensions are in millimeters, unless otherwise noted.

Dimensional Drawings

Valve Manifolds Type 44 VTSA – Metric Series

Dimensions¹⁾ Download CAD Data → www.festo.com/us/cad

Vertical stacking components

1 Solenoid valve
 2 Pressure regulator plate
 3 Flow control plate
 6 Manifold subbase
 7 90° connection plate
 8 Pressure gauge, freely positionable
 9 Standard rotary knob
 10 Lockable rotary knob

Width	L1	L2
18 mm	348.2	268.6
26 mm	365.7	286.1
42 mm	410.3	311.6

1) Dimensions are in millimeters, unless otherwise noted.

Dimensional Drawings

Valve Manifolds Type 44 VTSA – Metric Series

Dimensions¹⁾

Download CAD Data → www.festo.com/us/cad

Right-hand end plate

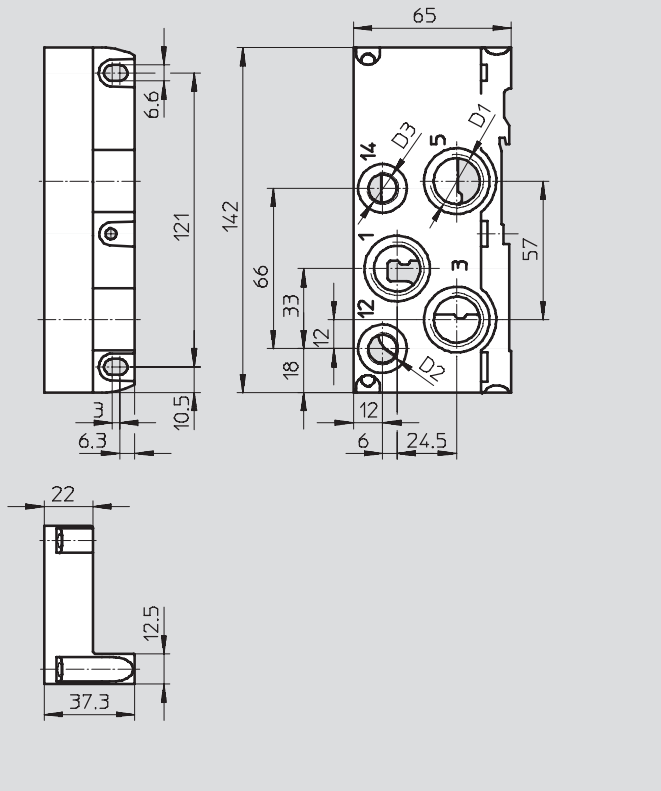

Right-hand end plate with pilot air selector

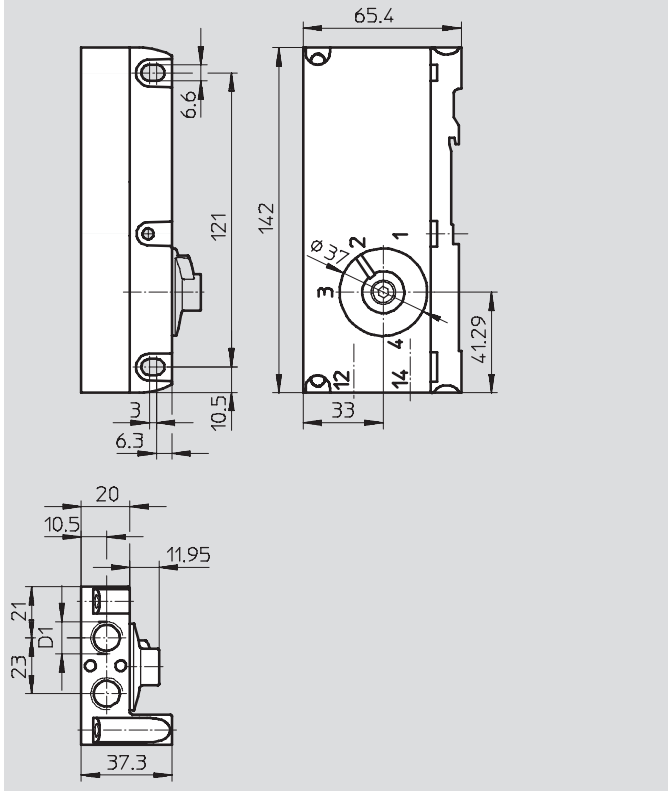

Type	D1	D2	D3
VABE-S6-1R-G12	G1/2	G1/4	G1/4
VABE-S6-1RZ-G12			

Type	D1
VABE-S6-1RZ-G-B1	G1/4

1) Dimensions are in millimeters, unless otherwise noted.

Note: This product conforms with the ISO 1179-1 standard and the ISO 228-1 standard.

Dimensional Drawings

Valve Manifolds Type 45 VTSA-F – Metric Series



Dimensions¹⁾

Download CAD Data → www.festo.com/us/cad

Valve manifold with individual electrical connection

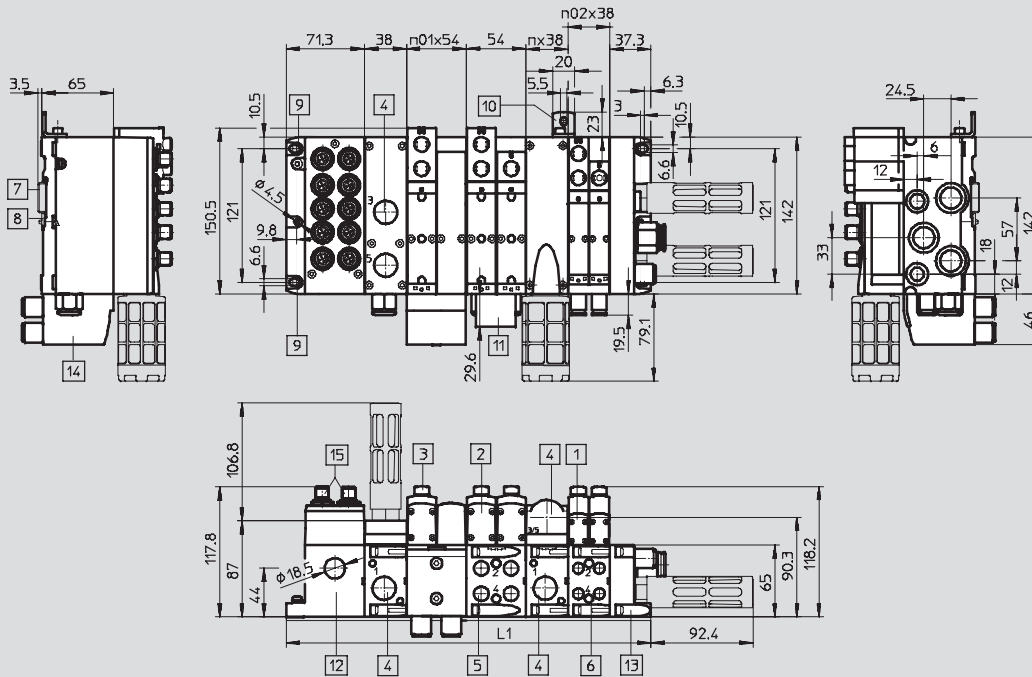

- | | | | |
|-----------------------------|---------------------------|--------------------------------------|---------------------------------------|
| 1 Solenoid valve 18 mm | 4 Threaded connection G½ | 10 Additional mounting bracket | n02 Number of manifold subbases 18 mm |
| 2 Solenoid valve 26 mm | 5 Threaded connection G¼ | 11 Inscription label holder | n01 Number of manifold subbases 26 mm |
| 3 Cover cap/manual override | 6 Threaded connection G¾ | 12 Individual connection | n Number of supply plates |
| | 7 DIN H-rail | 13 End plate | |
| | 8 DIN H-rail mounting kit | 14 90° connection plate | |
| | 9 Mounting hole | 15 M12 plug, 5-pin (6-way or 10-way) | |

Width	L1
18 mm	$71.3 + n02 \times 38 + n \times 38 + 37.3$
26 mm	$71.3 + n01 \times 54 + n \times 38 + 37.3$
Mixture of 18 mm and 26 mm	$71.3 + n02 \times 38 + n01 \times 54 + n \times 38 + 37.3$

1) Dimensions are in millimeters, unless otherwise noted.

Dimensional Drawings

Valve Manifolds Type 45 VTSA-F – Metric Series

Dimensions¹⁾

Download CAD Data → www.festo.com/us/cad

Valve manifold with multi-pin plug connection

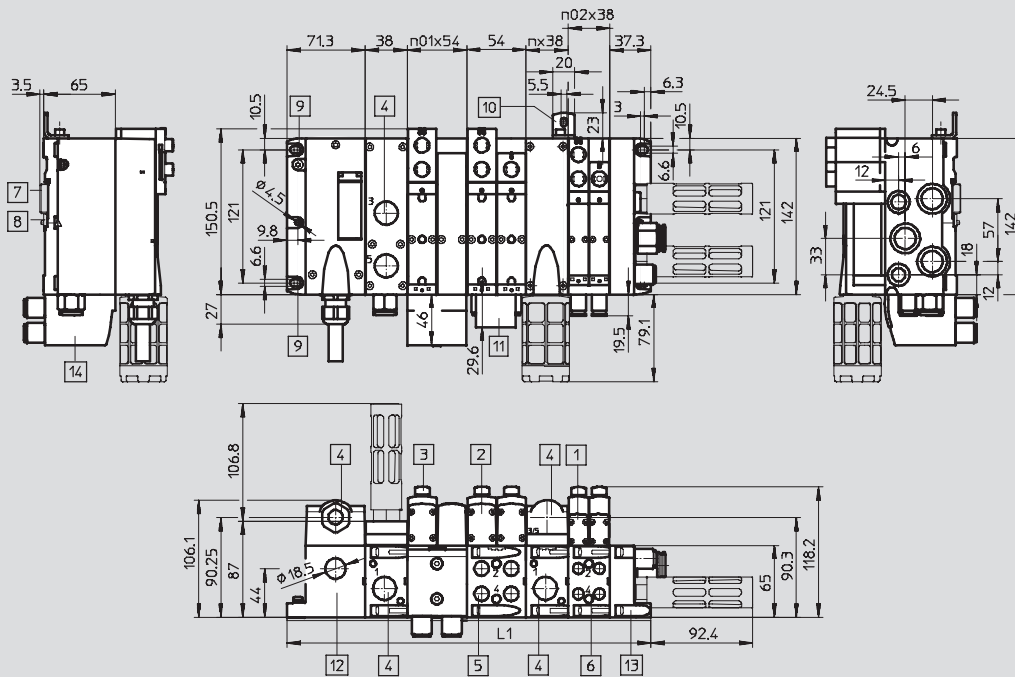

- | | | | |
|-----------------------------|----------------------------|--------------------------------|---------------------------------|
| 1 Solenoid valve 18 mm | 4 Threaded connection G1/2 | 8 DIN H-rail mounting kit | n02 Number of manifold subbases |
| 2 Solenoid valve 26 mm | 5 Threaded connection G1/4 | 9 Mounting hole | 18 mm |
| 3 Cover cap/manual override | 6 Threaded connection G1/8 | 10 Additional mounting bracket | n01 Number of manifold subbases |
| | 7 DIN H-rail | 11 Inscription label holder | 26 mm |
| | | 12 Multi-pin plug connection | n Number of supply plates |
| | | 13 End plate | |
| | | 14 90° connection plate | |

Width	L1
18 mm	$71.3 + n02 \times 38 + n \times 38 + 37.3$
26 mm	$71.3 + n01 \times 54 + n \times 38 + 37.3$
Mixture of 18 mm and 26 mm	$71.3 + n02 \times 38 + n01 \times 54 + n \times 38 + 37.3$

Supply plate with silencer

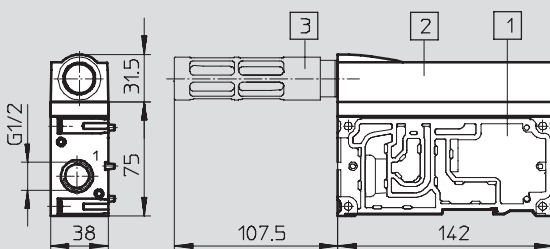

- | |
|----------------------|
| 1 Supply plate |
| 2 Exhaust port cover |
| 3 Silencer U-1/2-B |

1) Dimensions are in millimeters, unless otherwise noted.

Dimensional Drawings

Valve Manifolds Type 45 VTSA-F – Metric Series

Dimensions¹⁾ Download CAD Data → www.festo.com/us/cad

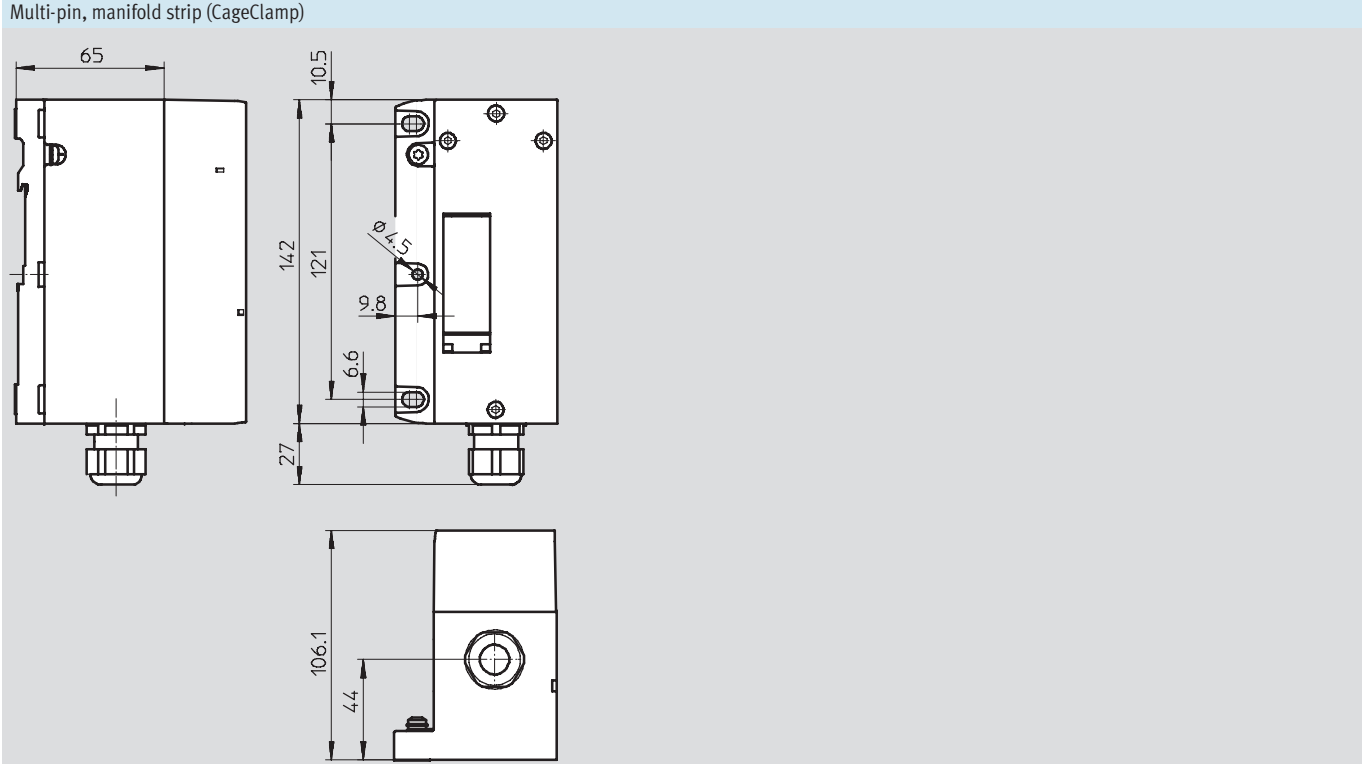

1) Dimensions are in millimeters, unless otherwise noted.

Dimensional Drawings

Valve Manifolds Type 45 VTSA-F – Metric Series



Dimensions¹⁾

Download CAD Data → www.festo.com/us/cad

Valve manifold with fieldbus connection

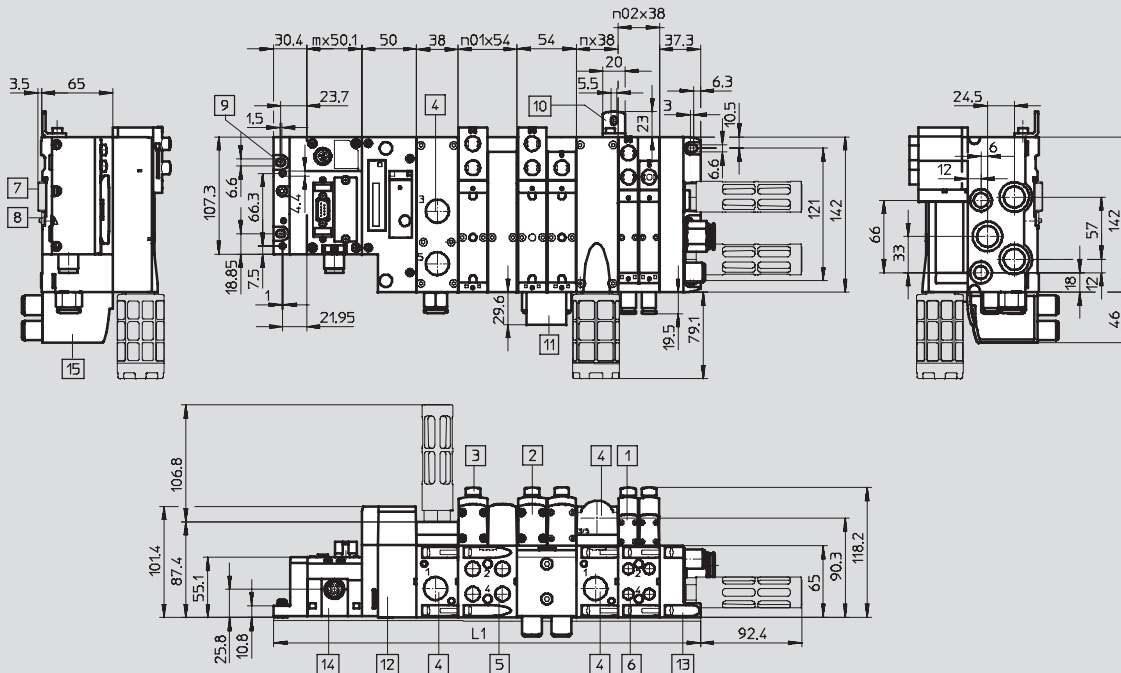

- | | | | |
|-----------------------------|---------------------------------------|--------------------------------|--|
| 1 Solenoid valve 18 mm | 4 Threaded connection G $\frac{1}{2}$ | 10 Additional mounting bracket | n02 Number of manifold subbases
18 mm |
| 2 Solenoid valve 26 mm | 5 Threaded connection G $\frac{1}{4}$ | 11 Inscription label holder | n01 Number of manifold subbases
26 mm |
| 3 Cover cap/manual override | 6 Threaded connection G $\frac{1}{8}$ | 12 Pneumatic interface CPX | n Number of supply plates |
| | 7 DIN H-rail | 13 End plate | m Number of CPX modules |
| | 8 DIN H-rail mounting kit | 14 CPX module/fieldbus node | |
| | 9 Mounting hole | 15 90° connection plate | |
| | | width 18 mm, G $\frac{1}{8}$ | |
| | | width 26 mm, G $\frac{1}{4}$ | |

Width	L1
18 mm	$30.4 + m \times 50.1 + 50 + n02 \times 38 + n \times 38 + 37.3$
26 mm	$30.4 + m \times 50.1 + 50 + n01 \times 54 + n \times 38 + 37.3$
Mixture of 18 mm and 26 mm	$30.4 + m \times 50.1 + 50 + n02 \times 38 + n01 \times 54 + n \times 38 + 37.3$

Supply plate with silencer

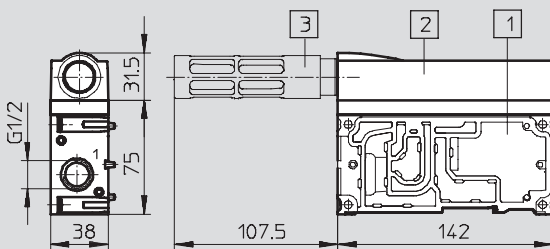

- | |
|--------------------------------|
| 1 Supply plate |
| 2 Exhaust port cover |
| 3 Silencer U- $\frac{1}{2}$ -B |

1) Dimensions are in millimeters, unless otherwise noted.

Dimensional Drawings

Valve Manifolds Type 45 VTSA-F – Metric Series

Dimensions¹⁾

Download CAD Data → www.festo.com/us/cad

Vertical stacking components, width 18 mm

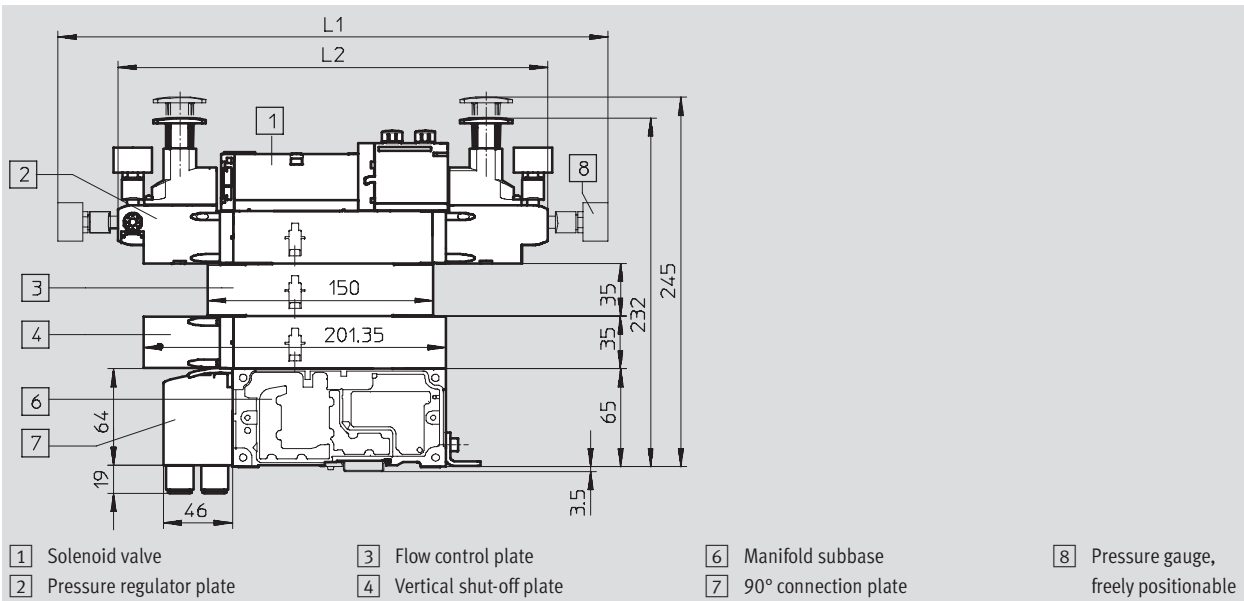
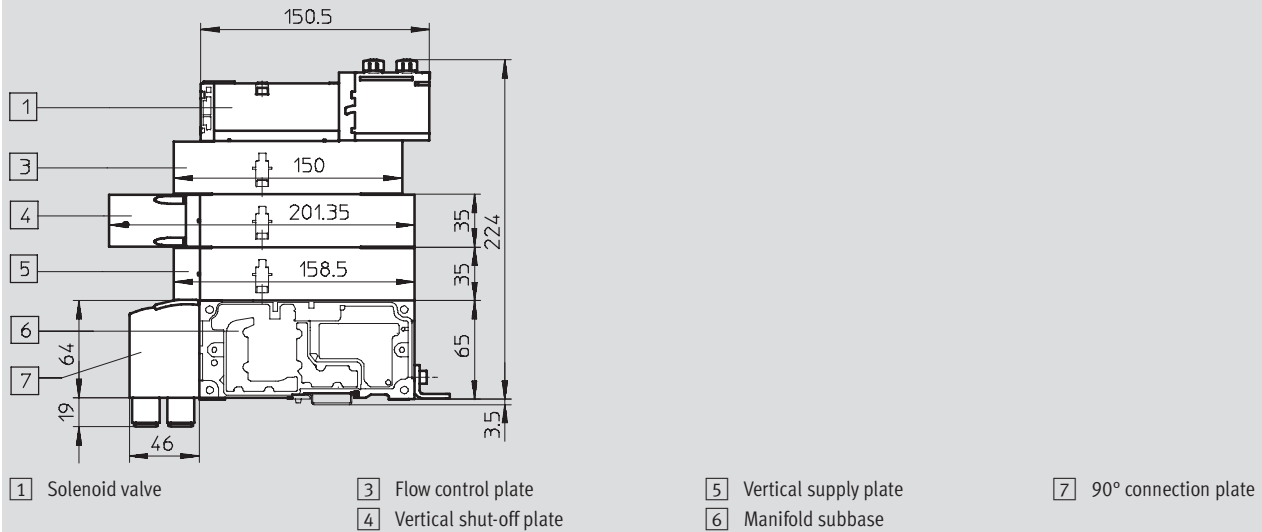

Width	L1	L2
18 mm	348.2	268.6
26 mm	365.7	286.1

1) Dimensions are in millimeters, unless otherwise noted.

Dimensional Drawings

Valve Manifolds Type 45 VTSA-F – Metric Series

Dimensions¹⁾ Download CAD Data → www.festo.com/us/cad

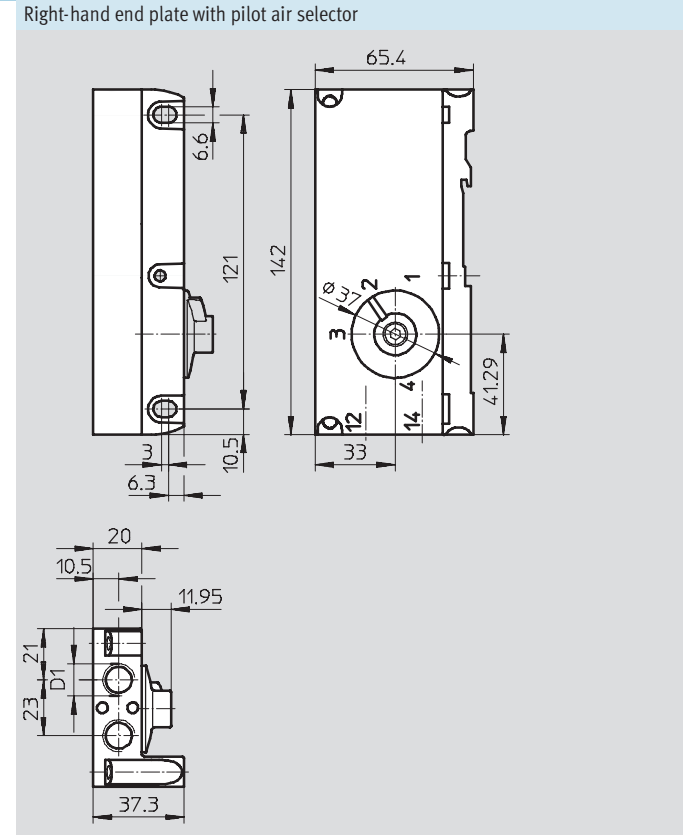
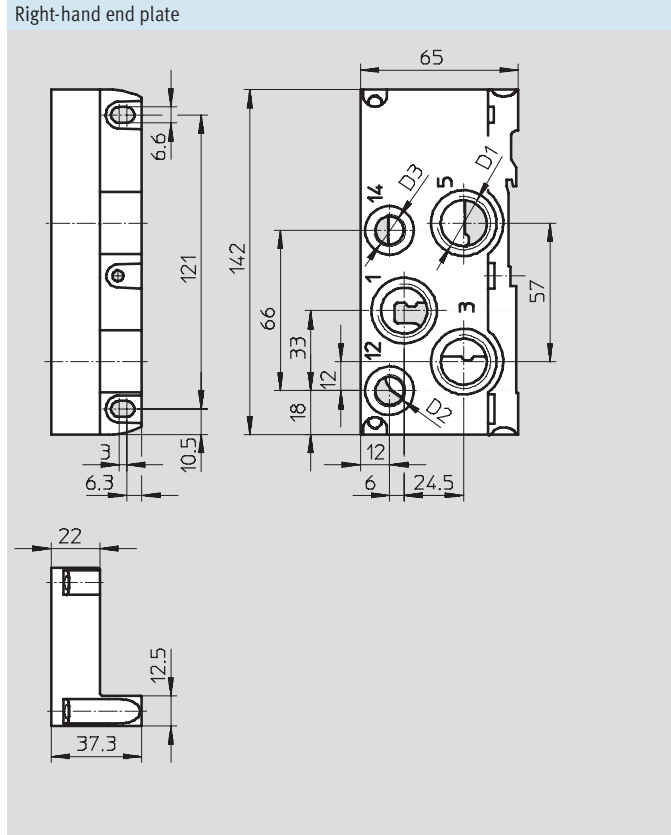

Type	D1	D2	D3
VABE-S6-1R-G12	G1/2	G1/4	G1/4
VABE-S6-1RZ-G12			

Type	D1
VABE-S6-1RZ-G-B1	G1/4

1) Dimensions are in millimeters, unless otherwise noted.

Note: This product conforms with the ISO 1179-1 standard and the ISO 228-1 standard.

Online Product Configurator

Valve Manifolds Type 44 VTSA, Type 45 VTSA-F – Metric Series



Configuring VTSA Valve Manifolds

Available via our online catalog at www.festo.com/catalog/vtsa

A product configurator is available to help you configure a VTSA valve manifold that best fits your needs.

The valve manifolds are fully assembled according to your order specifications and are individually tested. This reduces the amount of assembly and installation time required to a minimum.

Valve terminals are ordered using an order code.

Ordering data for type 44

→ 71

Ordering data for type 45

→ 81

Ordering data for CPX

→ www.festo.com/catalog/cpx

The illustration provides an example of a valve manifold configuration.

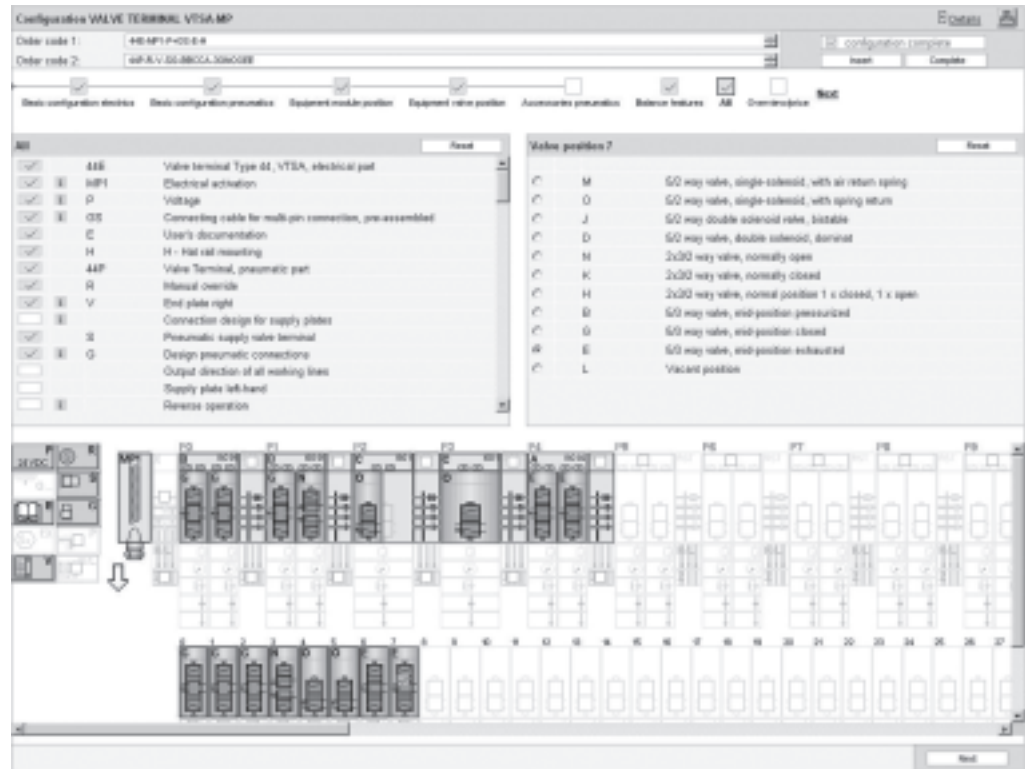

The following steps give a brief explanation of how to use the on-line Festo product configurator to determine an order code

From the Festo Industrial Automation home page www.festo.com/usa select the “Catalog” link from the “Products” menu at the top of the page; this will bring you directly to the home page for the Pneumatic Catalog.

From this location you may now use the search box, located above the Product Tree on the left hand side of the page, to perform a text based search for your product. Valid search criteria are “Part No.’s” (e.g. 539215, 547963, etc.), “Type” (e.g. VTSA, Type 44/45), or “Article Type” (e.g. valve manifold).

You may also visually navigate the catalog by using the product tree on the left or the product images off to the right.

Once you’ve located the style of VTSA (type 44 or 45, NPT or ISO, etc.) you want, click on the blue shopping basket icon (this does not initiate an order). Confirm the quantity required in the pop-up window and click Ok. You must now view your shopping basket to configure your manifold; click on the “Basket” link on the far-right side of the page and then on the configuration symbol. You can then configure the valve terminal step by step (from the top down) according to your requirements.

If you already have a complete order code, you may easily input it using the “Insert” button (upper right). The first order code (beginning with 44E or 45E) will specify your electrical configuration and options. The second part of the order code (beginning with 44P or 45P) will specify your pneumatic configuration and options.

As you make selections the product configurator will assist you by showing you various indicators along the way. Incompatible selections are indicated by a red box with an X in it. Incomplete “required” selections are indicated by a light green box. Incomplete “optional” selections are indicated by an empty box. Completed selections are indicated by a light blue box with a check mark in it.

Once you have selected all required components, look for the “Configuration Complete” indicator in the upper-right corner of the page. Press the “Complete” button to add the configured manifold to your basket for on-line order. On-line order is not required; you may also copy down your order code for future reference or phone/fax order.

Ordering Data – Configurable Products

Valve Manifolds Type 44 VTSA, G Thread for Multi-pin Plug – Electrical Part

M Mandatory Data				O Options		
Module No.	Valve manifold, electrical part	Electrical connection	Voltage	Connecting cable for multi-pin plug connection	User's manual	DIN H-rail mounting
539215	44E	T, MP1, MP2, MP3	P, Q	GA, GB, GC, GD, GE, GF, GG, GH, GI, GK, GL, GM, GN, GO, GP, GQ, GR, GS	D, E, F, I, S, V	H
Order example						
539215	44E	- MP1	- P	+ GE	- D	-
1	2	3	4	5	6	7

Ordering Table			Conditions	Code	Enter code	
M	1	Module No.	539215			
	2	Valve manifold, electrical part	Valve manifold type 44, VTSA, electrical multi-pin plug connection/manifold box		44E	
	3	Electrical connection	Multi-pin plug, CageClamp	1	-T	
			Electrical multi-pin plug connection, Sub-D (37-pin)	1	-MP1	
			Electrical multi-pin plug connection, individual connection with M12, 6-way	2	-MP2	
			Electrical multi-pin plug connection, individual connection with M12, 10-way	3	-MP3	
	4	Voltage	24 V DC		-P	
			110 V AC	5	-Q	
O	5	Electrical accessories			+	
	6	Connecting cable for multi-pin plug connection, pre-assembled, supplied loose	Polyurethane	Connecting cable for Sub-D, 2.5 m, 10-core, 8 solenoid coils	6	GA
			Connecting cable for Sub-D, 5 m, 10-core, 8 solenoid coils	6	GB	
			Connecting cable for Sub-D, 10 m, 10-core, 8 solenoid coils	6	GC	
			Connecting cable for Sub-D, 2.5 m, 26-core, 22 solenoid coils	6	GD	
			Connecting cable for Sub-D, 5 m, 26-core, 22 solenoid coils	6	GE	
			Connecting cable for Sub-D, 10 m, 26-core, 22 solenoid coils	6	GF	
			Connecting cable for Sub-D, 2.5 m, 37-core, 32 solenoid coils	6	GG	
			Connecting cable for Sub-D, 5 m, 37-core, 32 solenoid coils	6	GH	
			Connecting cable for Sub-D, 10 m, 37-core, 32 solenoid coils	6	GI	
			Polyvinyl chloride	Connecting cable for Sub-D, 2.5 m, 10-core, 8 solenoid coils	6	GK
			Connecting cable for Sub-D, 5 m, 10-core, 8 solenoid coils	6	GL	
			Connecting cable for Sub-D, 10 m, 10-core, 8 solenoid coils	6	GM	
			Connecting cable for Sub-D, 2.5 m, 27-core, 22 solenoid coils	6	GN	
			Connecting cable for Sub-D, 5 m, 27-core, 22 solenoid coils	6	GO	
			Connecting cable for Sub-D, 10 m, 27-core, 22 solenoid coils	6	GP	
			Connecting cable for Sub-D, 2.5 m, 37-core, 32 solenoid coils	6	GQ	
			Connecting cable for Sub-D, 5 m, 37-core, 32 solenoid coils	6	GR	
			Connecting cable for Sub-D, 10 m, 37-core, 32 solenoid coils	6	GS	
			7	User's manual	German	
	English				-E	
	French				-F	
	Italian				-I	
	Spanish				-S	
	Swedish				-V	
	7	DIN H-rail mounting	1		-H	

- 1 T, MP1 Max. 32 addresses can be selected
- 2 MP2 Max. 12 addresses can be selected
- 3 MP3 Max. 20 addresses can be selected

- 5 Q Only with electrical connection (3) T (multi-pin plug, CageClamp)
- 6 G... Not with electrical connection (3) T, MP2, MP3 and MP4

Ordering Data – Configurable Products

Valve Manifolds Type 44 VTSA, G Thread for Multi-pin Plug – Pneumatic Part

M Mandatory Data				O Options					
Module No.	Valve manifold, pneumatic part	Manual override	Right-hand end plate	Port configuration for supply plates	Pneumatic supply to valve manifold	Configuration of all pneumatic connections	Outgoing direction of all working lines	Left-hand supply plate	Reverse operation
539215	44P	N, R, V	V, X, Y, U, Z, W	K, L	S, V	M, N, G	P	X	Z
Order example									
539215	44P	R	V	K	S	M	P	X	
1	2	3	4	5	6	7	8	9	10

Ordering Table		Width	18 mm	26 mm	42 mm	Conditions	Code	Enter code
M	1	Module No.	539215	539215	539215			
	2	Valve manifold, pneumatic part	Valve manifold type 44, VTSA, modular subbase valves to ISO 15407-2, pneumatic connections with G thread				44P	
	3	Manual override	Pushing (non-detenting)				-N	
			Pushing/detenting				-R	
			Covered				-V	
	4	Right-hand end plate	Right-hand end plate, with supply air/exhaust air, internal pilot air supply				-V	
			Right-hand end plate with supply air/exhaust air, external pilot air supply				-X	
			End plate with pilot air selector, internal pilot air supply			1	-Y	
			End plate with pilot air selector, internal pilot air supply, ducted pilot exhaust air			1	-U	
			End plate with pilot air selector, external pilot air supply			1	-Z	
			End plate with pilot air selector, external pilot air supply, ducted pilot exhaust air			1	-W	
	5	Port configuration for supply plates	Normal operation: Supply port 1, exhaust port 3/5 separated			2	-K	
			Reverse operation: Exhaust port 1, supply port 3/5 separated					
			Normal operation: Supply port 1, exhaust port 3/5 common			2	-L	
			Reverse operation: Exhaust port 1, supply port 3/5 common					
	6	Pneumatic valve manifold supply (standard: threaded connection)	Silencer and QS push-in fittings				S	
			QS push-in fittings				V	
	7	Configuration of all pneumatic connections	QS push-in fittings, large			3	M	
			QS push-in fittings, small			3	N	
			QS push-in fittings, large and small mixed			3	G	
	8	Outgoing direction of all working lines (standard outlet at front)	90° connection plate, outlet at bottom				P	
	9	Left-hand supply plate	Left-hand supply plate in front of manifold subbase 00				X	
	10	Reverse operation	Reverse operation as of valve position 00			4	Z	

- 1 Y, U, Z, W At least one left-hand supply plate (9) X or one compressed air supply/duct separation (12) U, SU, TU, RU, USU, UTU or URU must be selected
- 2 K, L Must be selected if left-hand supply plate (9) X or one compressed air supply/duct separation (12) (S, T, R, U, SU, US, TU, UT, UR, USU, UTU, URU) was selected
- 3 M, N, G Must be selected if pneumatic valve manifold supply (6) S or V was selected
- 4 Z A reversible pressure zone cannot be terminated with a right-hand end plate (4) V, Y, U (internal pilot air supply)

Ordering Data – Configurable Products



Valve Manifolds Type 44 VTSA, G Thread for Multi-pin Plug – Pneumatic Part

→ 0 Options →

Pneumatic manifold subbases 00 ... 15

11 Type of interlinking block: A, B, C, E, F, G, AK, BK, CK, EK, FK, GK
 12 Compressed air supply/duct separation: S, T, R, U, SU, US, TU, UT, RU, UR, USU, UTU, URU
 13 Reverse operation: Z

Module position

00	01	02	03	04	05	06	07	08	09	10	11	12	13	14	15
A	B	B	BS	B											

11 + 12 + 13

Ordering Table		Width	18 mm	26 mm	42 mm	Condit ions	Code	Enter code
↓	11	Pneumatic manifold subbases				5	-	-
0		Type of interlinking block 00 ... 15	2 valve positions, 4 addresses	–	–		A	Enter the equipment selected in the order code
		Manifold subbase	–	2 valve positions, 4 addresses	–		B	
			–	–	1 valve position, 2 addresses		C	
			2 valve positions, 2 addresses	–	–	6	E	
			–	2 valve positions, 2 addresses	–	6	F	
			–	–	1 valve position, 1 address	6	G	
		Manifold subbase with QS push-in fittings, small	2 valve positions, 4 addresses	–	–	7	AK	
			–	2 valve positions, 4 addresses	–	7	BK	
			–	–	1 valve position, 2 addresses	7	CK	
			2 valve positions, 2 addresses	–	–	8	EK	
			–	2 valve positions, 2 addresses	–	8	FK	
			–	–	1 valve position, 1 address	8	GK	
	12	Compressed air supply/duct separation 00 ... 15	Duct separation 1, 3, 5			9 10	S	
			Duct separation 1			9 10	T	
			Duct separation 3, 5			9 10	R	
			Supply plate				U	
			Supply plate with duct separation 1, 3, 5 at left			9	SU	
			Supply plate with duct separation 1, 3, 5 at right			9	US	
			Supply plate with duct separation 1 at left			9	TU	
			Supply plate with duct separation 1 at right			9	UT	
			Supply plate with duct separation 3, 5 at left			9	RU	
			Supply plate with duct separation 3, 5 at right			9	UR	
			2 supply plates with duct separation 1, 3, 5 in centre				USU	
			2 supply plates with duct separation 1 in centre				UTU	
			2 supply plates with duct separation 3, 5 in centre				URU	
↓	13	Reverse operation 00 ... 15	Subsequent valve positions permitted for reverse operation			11	Z	

- 5 Manifold subbases must be fitted throughout without any gaps
- 6 E, F, G Only with valves (14) M, O and L
- 7 AK, BK, CK Only with configuration of all pneumatic connections (?) N or G
- 8 EK, FK, GK Only with configuration of all pneumatic connections (?) N or G.
Only with valves (14) M, O and L

- 9 S, T, R, SU, US, TU, UT, RU, UR No pressure-free zones may be created
- 10 S, T, R Cannot be selected on last manifold subbase
- 11 Z Only with compressed air supply/duct separation (12) S, SU, US or USU.
A reversible pressure zone cannot be terminated with a right-hand end plate (4) V, Y, U

Ordering Data – Configurable Products



Valve Manifolds Type 44 VTSA, G Thread for Multi-pin Plug – Pneumatic Part

→ 0 Options →

Pneumatic valve positions 00 ... 31

- 14 Valve position 00 ... 31: M, O, J, D, N, K, H, B, G, E, P, Q, R, L
- 15 Pressure regulator for position 00 ... 31: ZA, ZB, ZC, ZD, ZE, ZK, ZL, ZF, ZG, ZH, ZI, ZJ, ZM, ZN
- 16 Pressure indicator for position 00 ... 31: T, U
- 17 Flow control valve position 00 ... 31: X
- 18 Vertical pressure isolating plate for position 00 ... 31: ZT
- 19 Vertical supply plate for position 00 ... 31: ZU

Valve position		19 Vertical supply plate for position 00 ... 31: ZU																					
00	01	02	03	04	05	06	07	08	09	10	11	12	13	14	15	16	17	18	19	20	...	30	31
M	M	M	O	O	O	J	J	E	E												...		

14 + 15 + 16 + 17 + 18 + 19

Ordering Table		18 mm	26 mm	42 mm	Conditions	Code	Enter code	
↓	14 Pneumatic valve positions 00 ... 31					-	-	
	0 Valve position 00 ... 31	5/2-way valve, single solenoid with pneumatic spring return				M	Enter equipment selection for valve positions in order code	
		5/2-way valve, single solenoid with spring return				O		
		5/2-way valve, double solenoid				J		
		5/2-way valve, double solenoid with dominant signal				D		
		2x 3/2-way valve, normally open		12		N		
		2x 3/2-way valve, normally closed		12		K		
		2x 3/2-way valve, 1x normally closed, 1x normally open		12		H		
		5/3-way valve, mid-position pressurised				B		
		5/3-way valve, mid-position closed				G		
		5/3-way valve, mid-position exhausted				E		
		2x 3/2-way valve, normally open, reverse operation		13		P		
		2x 3/2-way valve, normally closed, reverse operation		13		Q		
		2x 3/2-way valve, 1x normally closed, 1x normally open, reverse operation		13		R		
		Vacant position				L		
↓	15 Pressure regulator for valve position 00 ... 31	Input pressure 10 bar	Pressure regulator plate for port 1		14	ZA		
			Pressure regulator plate for port 4			ZB		
		Pressure regulator plate for port 2			ZC			
		Pressure regulator plate for port 4/2			ZD			
		Pressure regulator plate for port 4/2, reversible		15	ZE			
		Pressure regulator plate for port 4, reversible		15	ZK			
		Pressure regulator plate for port 2, reversible		15	ZL			
	Input pressure 6 bar	Pressure regulator plate for port 1		14	ZF			
		Pressure regulator plate for port 4			ZG			
		Pressure regulator plate for port 2			ZH			
		Pressure regulator plate for port 4/2			ZI			
		Pressure regulator plate for port 4/2, reversible		15	ZJ			
		Pressure regulator plate for port 4, reversible		15	ZM			
		Pressure regulator plate for port 2, reversible		15	ZN			

- 12 N, K, H Not permitted in zones with reverse operation. Not with pressure regulator (15) ZE, ZJ (reversible pressure regulator plate)
- 13 P, Q, R Only permissible in zones with reverse operation or with pressure regulator (15) ZE, ZJ (reversible pressure regulator plate). Pilot pressure required on duct 12 (ducted exhaust air not possible). Not with right-hand end plate (4) Y, Z
- 14 ZA, ZF Not permitted in zones with reverse operation
- 15 ZE, ZK, ZL, ZJ, ZM, ZN Not permitted in zones with reverse operation. Not with 2x 3/2-way valves (14) N, K, H

Ordering Data – Configurable Products

Valve Manifolds Type 44 VTSA, G Thread for Multi-pin Plug – Pneumatic Part

➔ **0 Options**

Pneumatic accessories

U, ...B, ...T, ...N, ...V

+ **10N**
20

Ordering table						
Width	18 mm	26 mm	42 mm	Conditions	Code	Enter code
↓ 0	16 Pressure indicator for valve position 00 ... 31	Pressure gauge, 10 bar		16	T	Enter equipment selection for valve positions in order code
		Pressure gauge, 6 bar		17	U	
17	Flow control valve for valve position 00 ... 31	Flow control plate		18	X	
18	Vertical isolating plate for valve position 00 ... 31	Pressure separator plate on valve assembly		19	ZT	
19	Vertical supply plate for valve position 00 ... 31	Compressed air supply on valve		18	ZU	
20	Pneumatic accessories				+	
	Mounting brackets (pack of 5)	Supplied separately		20	U	+
	Inscription label holder for valves	5 ... 50			...B	
	Inscription label holder for manifold subbases	5 ... 50			...T	
	Cover cap for manual override, pushing	10 ... 90			...N	
	Cover cap for manual override, covered	10 ... 90			...V	

- 16 T Only with pressure regulator (15) ZA, ZB, ZC, ZD, ZE
- 17 U Only with pressure regulator (15) ZF, ZG, ZH, ZI, ZJ
- 18 X, ZU Not with valves with reverse operation (14) P, Q, R

- 19 ZT Not with right-hand end plate (4) Y, Z
- 20 U Can only be selected if there are more than 9 valve positions

Ordering Data – Configurable Products



Valve Manifolds Type 44 VTSA, G Thread for CPX – Pneumatic Part

M Mandatory Data				O Options					
Module No.	Valve manifold, pneumatic part	Manual override	Right-hand end plate	Port configuration for supply plates	Pneumatic supply to valve manifold	Configuration of all pneumatic connections	Outgoing direction of all working lines	Left-hand supply plate	Reverse operation
539217	44P	N, R, V	V, X, Y, U, Z, W	K, L	S, V	M, N, G	P	X	Z
Order example									
539217	44P	R	V	K	S	M	P	X	
1	2	3	4	5	6	7	8	9	10

Ordering Table		Width	18 mm	26 mm	42 mm	Conditions	Code	Enter code
M	1	Module No.	539217	539217	539217			
	2	Valve manifold, pneumatic part	Valve manifold type 44, VTSA, modular subbase valves to ISO 15407-2, pneumatic connections with G thread				44P	
	3	Manual override	Pushing (non-detenting)				-N	
			Pushing/detenting				-R	
			Covered				-V	
	4	Right-hand end plate	Right-hand end plate, with supply air/exhaust air, internal pilot air supply				-V	
			Right-hand end plate with supply air/exhaust air, external pilot air supply				-X	
			End plate with pilot air selector, internal pilot air supply			1	-Y	
			End plate with pilot air selector, internal pilot air supply, ducted pilot exhaust air			1	-U	
			End plate with pilot air selector, external pilot air supply			1	-Z	
			End plate with pilot air selector, external pilot air supply, ducted pilot exhaust air			1	-W	
	5	Port configuration for supply plates	Normal operation: Supply port 1, exhaust port 3/5 separated			2	-K	
			Reverse operation: Exhaust port 1, supply port 3/5 separated					
			Normal operation: Supply port 1, exhaust port 3/5 common			2	-L	
			Reverse operation: Exhaust port 1, supply port 3/5 common					
	6	Pneumatic valve manifold supply (standard: threaded connection)	Silencer and QS push-in fittings				S	
			QS push-in fittings				V	
	7	Configuration of all pneumatic connections	QS push-in fittings, large			3	M	
			QS push-in fittings, small			3	N	
			QS push-in fittings, large and small mixed			3	G	
	8	Outgoing direction of all working lines (standard outlet at front)	90° connection plate, outlet at bottom				P	
	9	Left-hand supply plate	Left-hand supply plate in front of manifold subbase 00				X	
	10	Reverse operation	Reverse operation as of valve position 00			4	Z	

- 1 Y, U, Z, W At least one left-hand supply plate (9) X or one compressed air supply/duct separation (12) U, SU, TU, RU, USU, UTU or URU must be selected
- 2 K, L Must be selected if left-hand supply plate (9) X or one compressed air supply/duct separation (12) (S, T, R, U, SU, US, TU, UT, RU, UR, USU, UTU, URU) was selected

- 3 M, N, G Must be selected if pneumatic valve manifold supply (6) S or V was selected
- 4 Z A reversible pressure zone cannot be terminated with a right-hand end plate (4) V, Y, U (internal pilot air supply)

Ordering Data – Configurable Products



Valve Manifolds Type 44 VTSA, G Thread for CPX – Pneumatic Part

→ 0 Options →

Pneumatic manifold subbases 00 ... 15

11 Type of interlinking block: A, B, C, E, F, G, AK, BK, CK, EK, FK, GK
 12 Compressed air supply/duct separation: S, T, R, U, SU, US, TU, UT, RU, UR, USU, UTU, URU
 13 Reverse operation: Z

Module position

00	01	02	03	04	05	06	07	08	09	10	11	12	13	14	15
A	B	B	BS	B											

11 + 12 + 13

Ordering Table		18 mm	26 mm	42 mm	Condit ions	Code	Enter code	
11	Pneumatic manifold subbases				5	-	-	
0	Type of interlinking block 00 ... 15	Manifold subbase	2 valve positions, 4 addresses	–	–	A	Enter the equipment selected in the order code	
			–	2 valve positions, 4 addresses	–	B		
			–	–	1 valve position, 2 addresses	C		
			2 valve positions, 2 addresses	–	–	6		E
			–	2 valve positions, 2 addresses	–	6		F
	Manifold subbase with QS push-in fittings, small	2 valve positions, 4 addresses	–	–	6	G		
		–	2 valve positions, 4 addresses	–	7	AK		
		–	–	1 valve position, 2 addresses	7	BK		
		2 valve positions, 2 addresses	–	–	7	CK		
		–	2 valve positions, 2 addresses	–	8	EK		
12	Compressed air supply/duct separation 00 ... 15	–	–	1 valve position, 1 address	8	FK		
		–	–	1 valve position, 1 address	8	GK		
		Duct separation 1, 3, 5			9	10	S	
		Duct separation 1			9	10	T	
		Duct separation 3, 5			9	10	R	
		Supply plate					U	
		Supply plate with duct separation 1, 3, 5 at left			9		SU	
		Supply plate with duct separation 1, 3, 5 at right			9		US	
		Supply plate with duct separation 1 at left			9		TU	
		Supply plate with duct separation 1 at right			9		UT	
		Supply plate with duct separation 3, 5 at left			9		RU	
		Supply plate with duct separation 3, 5 at right			9		UR	
		2 supply plates with duct separation 1, 3, 5 in centre					USU	
2 supply plates with duct separation 1 in centre					UTU			
2 supply plates with duct separation 3, 5 in centre					URU			
13	Reverse operation 00 ... 15	Subsequent valve positions permitted for reverse operation			11	Z		

- 5 Manifold subbases must be fitted throughout without any gaps
- 6 E, F, G Only with valves (14) M, O and L
- 7 AK, BK, CK Only with configuration of all pneumatic connections (?) N or G
- 8 EK, FK, GK Only with configuration of all pneumatic connections (?) N or G.
Only with valves (14) M, O and L

- 9 S, T, R, SU, US, TU, UT, RU, UR No pressure-free zones may be created
- 10 S, T, R Cannot be selected on last manifold subbase
- 11 Z Only with compressed air supply/duct separation (12) S, SU, US or USU.
A reversible pressure zone cannot be terminated with a right-hand end plate (4) V, Y, U

Ordering Data – Configurable Products

Valve Manifolds Type 44 VTSA, G Thread for CPX – Pneumatic Part



→ 0 Options →

Pneumatic valve positions 00 ... 31

- 14 Valve position 00 ... 31: M, O, J, D, N, K, H, B, G, E, P, Q, R, L
- 15 Pressure regulator for position 00 ... 31: ZA, ZB, ZC, ZD, ZE, ZK, ZL, ZF, ZG, ZH, ZI, ZJ, ZM, ZN
- 16 Pressure indicator for position 00 ... 31: T, U
- 17 Flow control valve position 00 ... 31: X
- 18 Vertical pressure isolating plate for position 00 ... 31: ZT
- 19 Vertical supply plate for position 00 ... 31: ZU

Valve position		19 Vertical supply plate for position 00 ... 31: ZU																					
00	01	02	03	04	05	06	07	08	09	10	11	12	13	14	15	16	17	18	19	20	...	30	31
M	M	M	O	O	O	J	J	E	E												...		

14 + 15 + 16 + 17 + 18 + 19

Ordering Table		18 mm	26 mm	42 mm	Conditions	Code	Enter code	
14	Pneumatic valve positions 00 ... 31					-	-	
0	Valve position 00 ... 31	5/2-way valve, single solenoid with pneumatic spring return				M	Enter equipment selection for valve positions in order code	
		5/2-way valve, single solenoid with spring return				O		
		5/2-way valve, double solenoid						J
		5/2-way valve, double solenoid with dominant signal						D
		2x 3/2-way valve, normally open				12		N
		2x 3/2-way valve, normally closed				12		K
		2x 3/2-way valve, 1x normally closed, 1x normally open				12		H
		5/3-way valve, mid-position pressurised						B
		5/3-way valve, mid-position closed						G
		5/3-way valve, mid-position exhausted						E
		2x 3/2-way valve, normally open, reverse operation				13		P
		2x 3/2-way valve, normally closed, reverse operation				13		Q
		2x 3/2-way valve, 1x normally closed, 1x normally open, reverse operation				13		R
		Vacant position						L
15	Pressure regulator for valve position 00 ... 31	Input pressure 10 bar	Pressure regulator plate for port 1			14	ZA	
			Pressure regulator plate for port 4				ZB	
			Pressure regulator plate for port 2				ZC	
			Pressure regulator plate for port 4/2				ZD	
			Pressure regulator plate for port 4/2, reversible			15	ZE	
			Pressure regulator plate for port 4, reversible			15	ZK	
		Input pressure 6 bar	Pressure regulator plate for port 2, reversible			15	ZL	
			Pressure regulator plate for port 1			14	ZF	
			Pressure regulator plate for port 4				ZG	
			Pressure regulator plate for port 2				ZH	
			Pressure regulator plate for port 4/2				ZI	
			Pressure regulator plate for port 4/2, reversible			15	ZJ	
			Pressure regulator plate for port 4, reversible			15	ZM	
			Pressure regulator plate for port 2, reversible			15	ZN	

- 12 N, K, H Not permitted in zones with reverse operation. Not with pressure regulator (15) ZE, ZJ (reversible pressure regulator plate)
- 13 P, Q, R Only permissible in zones with reverse operation or with pressure regulator (15) ZE, ZJ (reversible pressure regulator plate). Pilot pressure required on duct 12 (ducted exhaust air not possible). Not with right-hand end plate (4) Y, Z

- 14 ZA, ZF Not permitted in zones with reverse operation.
- 15 ZE, ZK, ZL, ZJ, ZM, ZN Not permitted in zones with reverse operation. Not with 2x 3/2-way valves (14) N, K, H

Ordering Data – Configurable Products

Valve Manifolds Type 44 VTSA, G Thread for CPX – Pneumatic Part

➔ **0 Options**

Pneumatic accessories

U, ...B, ...T, ...N, ...V

+ **10N**
20

Ordering Table						
Width	18 mm	26 mm	42 mm	Conditions	Code	Enter code
16	Pressure indicator for valve position 00 ... 31	Pressure gauge, 10 bar		16	T	Enter equipment selection for valve positions in order code
		Pressure gauge, 6 bar		17	U	
17	Flow control valve for valve position 00 ... 31	Flow control plate		18	X	
18	Vertical isolating plate for valve position 00 ... 31	Pressure separator plate on valve assembly		19	ZT	
19	Vertical supply plate for valve position 00 ... 31	Compressed air supply on valve		18	ZU	
20	Pneumatic accessories				+	
	Mounting brackets (pack of 5)	Supplied separately		20	U	
	Inscription label holder for valves	5 ... 50			...B	
	Inscription label holder for manifold subbases	5 ... 50			...T	
	Cover cap for manual override, pushing	10 ... 90			...N	
	Cover cap for manual override, covered	10 ... 90			...V	

- 16 T Only with pressure regulator (15) ZA, ZB, ZC, ZD, ZE
- 17 U Only with pressure regulator (15) ZF, ZG, ZH, ZI, ZJ
- 18 X, ZU Not with valves with reverse operation (14) P, Q, R

- 19 ZT Not with right-hand end plate (4) Y, Z
- 20 U Can only be selected if there are more than 9 valve positions. Cannot be combined with DIN H-rail

Ordering Data – Configurable Products

Valve Manifolds Type 44 VTSA, G Thread – Pneumatic Part

FESTO

Sizes of Pneumatic Connections						
		Code	Duct	Width		
				18 mm	26 mm	42 mm – size 1
7		Configuration of all pneumatic connections				
4	Right-hand end plate V, X, Y, U, Z, W	M	12, 14	G $\frac{1}{4}$ (QS-G $\frac{1}{4}$ -10)	G $\frac{1}{4}$ (QS-G $\frac{1}{4}$ -10)	G $\frac{1}{4}$ (QS-G $\frac{1}{4}$ -10)
		G	12, 14	G $\frac{1}{4}$ (QS-G $\frac{1}{4}$ -10)	G $\frac{1}{4}$ (QS-G $\frac{1}{4}$ -10)	G $\frac{1}{4}$ (QS-G $\frac{1}{4}$ -10)
		N	12, 14	G $\frac{1}{4}$ (QS-G $\frac{1}{4}$ -8)	G $\frac{1}{4}$ (QS-G $\frac{1}{4}$ -8)	G $\frac{1}{4}$ (QS-G $\frac{1}{4}$ -8)
4	Right-hand end plate V, X, U	M	1, 3, 5	G $\frac{1}{2}$ (QS-G $\frac{1}{2}$ -16)	G $\frac{1}{2}$ (QS-G $\frac{1}{2}$ -16)	G $\frac{1}{2}$ (QS-G $\frac{1}{2}$ -16)
		G	1, 3, 5	G $\frac{1}{2}$ (QS-G $\frac{1}{2}$ -16)	G $\frac{1}{2}$ (QS-G $\frac{1}{2}$ -16)	G $\frac{1}{2}$ (QS-G $\frac{1}{2}$ -16)
		N	1, 3, 5	G $\frac{1}{2}$ (QS-G $\frac{1}{2}$ -12)	G $\frac{1}{2}$ (QS-G $\frac{1}{2}$ -12)	G $\frac{1}{2}$ (QS-G $\frac{1}{2}$ -12)
9	Left-hand supply plate X	M	1, 3, 5	G $\frac{1}{2}$ (QS-G $\frac{1}{2}$ -16)	G $\frac{1}{2}$ (QS-G $\frac{1}{2}$ -16)	G $\frac{1}{2}$ (QS-G $\frac{1}{2}$ -16)
		G	1, 3, 5	G $\frac{1}{2}$ (QS-G $\frac{1}{2}$ -16)	G $\frac{1}{2}$ (QS-G $\frac{1}{2}$ -16)	G $\frac{1}{2}$ (QS-G $\frac{1}{2}$ -16)
		N	1, 3, 5	G $\frac{1}{2}$ (QS-G $\frac{1}{2}$ -12)	G $\frac{1}{2}$ (QS-G $\frac{1}{2}$ -12)	G $\frac{1}{2}$ (QS-G $\frac{1}{2}$ -12)
11	Type of interlinking block Large A, B, C, E, F, G	M	2, 4	G $\frac{1}{8}$ (QS-G $\frac{1}{8}$ -8)	G $\frac{1}{4}$ (QS-G $\frac{1}{4}$ -10)	G $\frac{3}{8}$ (QS-G $\frac{3}{8}$ -12)
11	Type of interlinking block Small AK, BK, CK, EK, FK, GK	N	2, 4	G $\frac{1}{8}$ (QS-G $\frac{1}{8}$ -6)	G $\frac{1}{4}$ (QS-G $\frac{1}{4}$ -8)	G $\frac{3}{8}$ (QS-G $\frac{3}{8}$ -10)

Ordering Data – Configurable Products

Valve Manifolds Type 45 VTSA-F, G Thread for Multi-pin Plug – Electrical Part

M Mandatory Data				O Options		
Module No.	Valve manifold, electrical part	Electrical connection	Voltage	Connecting cable for multi-pin plug connection	User's manual	DIN H-rail mounting
547963	45E	T, MP1, MP2, MP3, MP4	P, Q	GA, GB, GC, GD, GE, GF, GG, GH, GI, GK, GL, GM, GN, GO, GP, GQ, GR, GS	D, E, F, I, S, V	H
Order example						
547963	45E	- MP1	- P	+ GE	- D	-
1	2	3	4	5	6	7

Ordering Table			Conditions	Code	Enter code	
M	1	Module No.	547963			
	2	Valve manifold, electrical part	Valve manifold type 45, VTSA-F, electrical multi-pin plug connection/manifold box		45E	
	3	Electrical connection	Multi-pin plug, CageClamp	1	-T	
			Electrical multi-pin plug connection, Sub-D (37-pin)	1	-MP1	
			Electrical multi-pin plug connection, individual connection with M12, 6-way	2	-MP2	
			Electrical multi-pin plug connection, individual connection with M12, 10-way	3	-MP3	
			Electrical multi-pin plug connection, round plug connector (19-pin), M23	4	-MP4	
	4	Voltage	24 V DC		-P	
			110 V AC	5	-Q	
O	5	Electrical accessories			+	
	6	Connecting cable for multi-pin plug connection, pre-assembled, supplied loose	Polyurethane	Connecting cable for Sub-D, 2.5 m, 10-core, 8 solenoid coils	6	GA
			Connecting cable for Sub-D, 5 m, 10-core, 8 solenoid coils	6	GB	
			Connecting cable for Sub-D, 10 m, 10-core, 8 solenoid coils	6	GC	
			Connecting cable for Sub-D, 2.5 m, 26-core, 22 solenoid coils	6	GD	
			Connecting cable for Sub-D, 5 m, 26-core, 22 solenoid coils	6	GE	
			Connecting cable for Sub-D, 10 m, 26-core, 22 solenoid coils	6	GF	
			Connecting cable for Sub-D, 2.5 m, 37-core, 32 solenoid coils	6	GG	
			Connecting cable for Sub-D, 5 m, 37-core, 32 solenoid coils	6	GH	
			Connecting cable for Sub-D, 10 m, 37-core, 32 solenoid coils	6	GI	
			Polyvinyl chloride	Connecting cable for Sub-D, 2.5 m, 10-core, 8 solenoid coils	6	GK
			Connecting cable for Sub-D, 5 m, 10-core, 8 solenoid coils	6	GL	
			Connecting cable for Sub-D, 10 m, 10-core, 8 solenoid coils	6	GM	
			Connecting cable for Sub-D, 2.5 m, 27-core, 22 solenoid coils	6	GN	
			Connecting cable for Sub-D, 5 m, 27-core, 22 solenoid coils	6	GO	
			Connecting cable for Sub-D, 10 m, 27-core, 22 solenoid coils	6	GP	
			Connecting cable for Sub-D, 2.5 m, 37-core, 32 solenoid coils	6	GQ	
			Connecting cable for Sub-D, 5 m, 37-core, 32 solenoid coils	6	GR	
			Connecting cable for Sub-D, 10 m, 37-core, 32 solenoid coils	6	GS	
			6	User's manual	German	
	English				-E	
	French				-F	
	Italian				-I	
	Spanish				-S	
	Swedish				-V	
	7	DIN H-rail mounting	1		-H	

- 1 T, MP1 Max. 32 addresses can be selected
- 2 MP2 Max. 12 addresses can be selected
- 3 MP3 Max. 20 addresses can be selected

- 4 MP4 Max. 16 addresses can be selected
- 5 Q Only with electrical connection (3) T (multi-pin plug, CageClamp)
- 6 G... Not with electrical connection (3) T, MP2, MP3 and MP4

Ordering Data – Configurable Products

Valve Manifolds Type 45 VTSA-F, G Thread for Multi-pin Plug – Pneumatic Part

M Mandatory Data				O Options					
Module No.	Valve manifold, pneumatic part	Manual override	Right-hand end plate	Port configuration for supply plates	Pneumatic supply to valve manifold	Configuration of all pneumatic connections	Outgoing direction of all working lines	Left-hand supply plate	Reverse operation
547963	45P	N, R, V	V, X, Y, U, Z, W	K, L	S, V	M, N, G	P	X	Z
Order example									
547963	45P	R	V	K	S	M	P	X	
1	2	3	4	5	6	7	8	9	10

Ordering Table		Width	18 mm	26 mm	Conditions	Code	Enter code
M	1	Module No.	547963	547963			
	2	Valve manifold, pneumatic part	Valve manifold type 45, VTSA-F, modular subbase valves, optimized for flow rate, pneumatic connections with G thread			45P	
	3	Manual override	Pushing (non-detenting)			-N	
			Pushing/detenting			-R	
			Covered			-V	
	4	Right-hand end plate	Right-hand end plate, with supply air/exhaust air, internal pilot air supply			-V	
			Right-hand end plate with supply air/exhaust air, external pilot air supply			-X	
			End plate with pilot air selector, internal pilot air supply		1	-Y	
			End plate with pilot air selector, internal pilot air supply, ducted pilot exhaust air		1	-U	
			End plate with pilot air selector, external pilot air supply		1	-Z	
			End plate with pilot air selector, external pilot air supply, ducted pilot exhaust air		1	-W	
O	5	Port configuration for supply plates	Normal operation: Supply port 1, exhaust port 3/5 separated		2	-K	
			Reverse operation: Exhaust port 1, supply port 3/5 separated				
			Normal operation: Supply port 1, exhaust port 3/5 common		2	-L	
			Reverse operation: Exhaust port 1, supply port 3/5 common				
	6	Pneumatic valve manifold supply (standard: threaded connection)	Silencer and QS push-in fittings			S	
			QS push-in fittings			V	
	7	Configuration of all pneumatic connections	QS push-in fittings, large		3	M	
			QS push-in fittings, small		3	N	
			QS push-in fittings, large and small mixed		3	G	
	8	Outgoing direction of all working lines (standard outlet at front)	90° connection plate, outlet at bottom			P	
	9	Left-hand supply plate	Left-hand supply plate in front of manifold subbase 00			X	
	10	Reverse operation	Reverse operation as of valve position 00		4	Z	

- 1 Y, U, Z, W At least one left-hand supply plate (9) X or one compressed air supply/duct separation (12) U, SU, TU, RU, USU, UTU or URU must be selected
- 2 K, L Must be selected if left-hand supply plate (9) X or one compressed air supply/duct separation (12) (S, T, R, U, SU, US, TU, UT, RU, UR, USU, UTU, URU) was selected
- 3 M, N, G Must be selected if pneumatic valve manifold supply (6) S or V was selected
- 4 Z A reversible pressure zone cannot be terminated with a right-hand end plate (4) V, Y, U (internal pilot air supply)

Ordering Data – Configurable Products



Valve Manifolds Type 45 VTSA-F, G Thread for Multi-pin Plug – Pneumatic Part

→ 0 Options →

Pneumatic manifold subbases 00 ... 15

11 Type of interlinking block: A, B, E, F, AK, BK, EK, FK
 12 Compressed air supply/duct separation: S, T, R, U, SU, US, TU, UT, RU, UR, USU, UTU, URU
 13 Reverse operation: Z

Module position

00	01	02	03	04	05	06	07	08	09	10	11	12	13	14	15
A	B	B	BS	B											

11 + 12 + 13

Ordering Table		18 mm	26 mm	Conditions	Code	Enter code	
11	Pneumatic manifold subbases			5	-	-	
0	Type of interlinking block 00 ... 15	Manifold subbase	2 valve positions, 4 addresses	-	A	Enter the equipment selected in the order code	
			-	2 valve positions, 4 addresses	B		
			2 valve positions, 2 addresses	-	6		E
			-	2 valve positions, 2 addresses	6		F
	Manifold subbase with QS push-in fittings, small	2 valve positions, 4 addresses	-	7	AK		
		-	2 valve positions, 4 addresses	7	BK		
		2 valve positions, 2 addresses	-	8	EK		
		-	2 valve positions, 2 addresses	8	FK		
12	Compressed air supply/duct separation 00 ... 15	Duct separation 1, 3, 5		9 10	S		
		Duct separation 1		9 10	T		
		Duct separation 3, 5		9 10	R		
		Supply plate			U		
		Supply plate with duct separation 1, 3, 5 at left		9	SU		
		Supply plate with duct separation 1, 3, 5 at right		9	US		
		Supply plate with duct separation 1 at left		9	TU		
		Supply plate with duct separation 1 at right		9	UT		
		Supply plate with duct separation 3, 5 at left		9	RU		
		Supply plate with duct separation 3, 5 at right		9	UR		
		2 supply plates with duct separation 1, 3, 5 in centre			USU		
		2 supply plates with duct separation 1 in centre			UTU		
2 supply plates with duct separation 3, 5 in centre			URU				
13	Reverse operation 00 ... 15	Subsequent valve positions permitted for reverse operation		11	Z		

- 5 Manifold subbases must be fitted throughout without any gaps
- 6 E, F Only with valves (14) M, O and L
- 7 AK, BK Only with configuration of all pneumatic connections (7) N or G
- 8 EK, FK Only with configuration of all pneumatic connections (7) N or G
Only with valves (14) M, O and L

- 9 S, T, R, SU, US, TU, UT, RU, UR No pressure-free zones may be created
- 10 S, T, R Cannot be selected on last manifold subbase
- 11 Z Only with compressed air supply/duct separation (12) S, SU, US or USU.
A reversible pressure zone cannot be terminated with a right-hand end plate (4) V, Y, U

Ordering Data – Configurable Products



Valve Manifolds Type 45 VTSA-F, G Thread for Multi-pin Plug – Pneumatic Part

→ 0 Options →

Pneumatic valve positions 00 ... 31

- 14 Valve position 00 ... 31: M, O, J, D, N, K, H, B, G, E, P, Q, R, L
- 15 Pressure regulator for position 00 ... 31: ZA, ZB, ZC, ZD, ZE, ZK, ZL, ZF, ZG, ZH, ZI, ZJ, ZM, ZN
- 16 Pressure indicator for position 00 ... 31: T, U
- 17 Flow control valve position 00 ... 31: X
- 18 Vertical pressure isolating plate for position 00 ... 31: ZT
- 19 Vertical supply plate for position 00 ... 31: ZU

Valve position		19 Vertical supply plate for position 00 ... 31: ZU																					
00	01	02	03	04	05	06	07	08	09	10	11	12	13	14	15	16	17	18	19	20	...	30	31
M	M	M	O	O	O	J	J	E	E												...		

14 + 15 + 16 + 17 + 18 + 19

Ordering Table		18 mm	26 mm	Conditions	Code	Enter code
↓	14 Pneumatic valve positions 00 ... 31				-	-
	0 Valve position 00 ... 31	5/2-way valve, single solenoid with pneumatic spring return			M	Enter equipment selection for valve positions in order code
		5/2-way valve, single solenoid with spring return			O	
		5/2-way valve, double solenoid			J	
		5/2-way valve, double solenoid with dominant signal			D	
		2x 3/2-way valve, normally open	12		N	
		2x 3/2-way valve, normally closed	12		K	
		2x 3/2-way valve, 1x normally closed, 1x normally open	12		H	
		5/3-way valve, mid-position pressurised			B	
		5/3-way valve, mid-position closed			G	
		5/3-way valve, mid-position exhausted			E	
		2x 3/2-way valve, normally open, reverse operation	13		P	
		2x 3/2-way valve, normally closed, reverse operation	13		Q	
		2x 3/2-way valve, 1x normally closed, 1x normally open, reverse operation	13		R	
		Vacant position			L	
↓	15 Pressure regulator for valve position 00 ... 31	Input pressure 10 bar	Pressure regulator plate for port 1	14	ZA	
			Pressure regulator plate for port 4		ZB	
		Pressure regulator plate for port 2		ZC		
		Pressure regulator plate for port 4/2		ZD		
		Pressure regulator plate for port 4/2, reversible	15	ZE		
		Pressure regulator plate for port 4, reversible	15	ZK		
		Pressure regulator plate for port 2, reversible	15	ZL		
	Input pressure 6 bar	Pressure regulator plate for port 1	14	ZF		
		Pressure regulator plate for port 4		ZG		
		Pressure regulator plate for port 2		ZH		
		Pressure regulator plate for port 4/2		ZI		
		Pressure regulator plate for port 4/2, reversible	15	ZJ		
		Pressure regulator plate for port 4, reversible	15	ZM		
		Pressure regulator plate for port 2, reversible	15	ZN		

- 12 N, K, H Not permitted in zones with reverse operation. Not with pressure regulator (15) ZE, ZJ (reversible pressure regulator plate)
- 13 P, Q, R Only permissible in zones with reverse operation or with pressure regulator (15) ZE, ZJ (reversible pressure regulator plate). Pilot pressure required on duct 12 (ducted exhaust air not possible). Not with right-hand end plate (4) Y, Z
- 14 ZA, ZF Not permitted in zones with reverse operation
- 15 ZE, ZK, ZL, ZJ, ZM, ZN Not permitted in zones with reverse operation. Not with 2x 3/2-way valves (14) N, K, H

Ordering Data – Configurable Products

Valve Manifolds Type 45 VTSA-F, G Thread for Multi-pin Plug – Pneumatic Part

➔ 0 Options

Pneumatic accessories

U, ...B, ...T, ...N, ...V

+ 10N
20

Ordering Table						
Width	18 mm	26 mm	Conditions	Code	Enter code	
0	16 Pressure indicator for valve position 00 ... 31	Pressure gauge, 10 bar	16	T	Enter equipment selection for valve positions in order code	
		Pressure gauge, 6 bar	17	U		
17	Flow control valve for valve position 00 ... 31	Flow control plate	18	X		
18	Vertical isolating plate for valve position 00 ... 31	Pressure separator plate on valve assembly	19	ZT		
19	Vertical supply plate for valve position 00 ... 31	Compressed air supply on valve	18	ZU		
20	Pneumatic accessories			+		+
	Mounting brackets (pack of 5)	Supplied separately	20	U		
	Inscription label holder for valves	5 ... 50		...B		
	Inscription label holder for manifold subbases	5 ... 50		...T		
	Cover cap for manual override, pushing	10 ... 90		...N		
	Cover cap for manual override, covered	10 ... 90		...V		

- 16 T Only with pressure regulator (15) ZA, ZB, ZC, ZD, ZE
- 17 U Only with pressure regulator (15) ZF, ZG, ZH, ZI, ZJ
- 18 X, ZU Not with valves with reverse operation (14) P, Q, R

- 19 ZT Not with right-hand end plate (4) Y, Z
- 20 U Can only be selected if there are more than 9 valve positions

Ordering Data – Configurable Products



Valve Manifolds Type 45 VTSA-F, G Thread for CPX – Pneumatic Part

M Mandatory Data				O Options					
Module No.	Valve Manifold, pneumatic part	Manual override	Right-hand end plate	Port configuration for supply plates	Pneumatic supply to valve manifold	Configuration of all pneumatic connections	Outgoing direction of all working lines	Left-hand supply plate	Reverse operation
547965	45P	N, R, V	V, X, Y, U, Z, W	K, L	S, V	M, N, G	P	X	Z
Order example									
547965	45P	R	V	K	S	M	P	X	
1	2	3	4	5	6	7	8	9	10

Ordering table		Width	18 mm	26 mm	Conditions	Code	Enter code
M	1	Module No.	547965	547965			
	2	Valve Manifold, pneumatic part	Valve Manifold type 45, VTSA-F, modular subbase valves, optimized for flow rate, pneumatic connections with G thread			45P	
	3	Manual override	Pushing (non-detenting)			-N	
			Pushing/detenting			-R	
			Covered			-V	
	4	Right-hand end plate	Right-hand end plate, with supply air/exhaust air, internal pilot air supply			-V	
			Right-hand end plate with supply air/exhaust air, external pilot air supply			-X	
			End plate with pilot air selector, internal pilot air supply		1	-Y	
			End plate with pilot air selector, internal pilot air supply, ducted pilot exhaust air		1	-U	
			End plate with pilot air selector, external pilot air supply		1	-Z	
			End plate with pilot air selector, external pilot air supply, ducted pilot exhaust air		1	-W	
	5	Port configuration for supply plates	Normal operation: Supply port 1, exhaust port 3/5 separated		2	-K	
			Reverse operation: Exhaust port 1, supply port 3/5 separated				
			Normal operation: Supply port 1, exhaust port 3/5 common		2	-L	
			Reverse operation: Exhaust port 1, supply port 3/5 common				
	6	Pneumatic valve manifold supply (standard: threaded connection)	Silencer and QS push-in fittings			S	
			QS push-in fittings			V	
	7	Configuration of all pneumatic connections	QS push-in fittings, large		3	M	
			QS push-in fittings, small		3	N	
			QS push-in fittings, large and small mixed		3	G	
	8	Outgoing direction of all working lines (standard outlet at front)	90° connection plate, outlet at bottom			P	
	9	Left-hand supply plate	Left-hand supply plate in front of manifold subbase 00			X	
	10	Reverse operation	Reverse operation as of valve position 00		4	Z	

- 1 Y, U, Z, W At least one left-hand supply plate (9) X or one compressed air supply/duct separation (12) U, SU, TU, RU, USU, UTU or URU must be selected
- 2 K, L Must be selected if left-hand supply plate (9) X or one compressed air supply/duct separation (12) (S, T, R, U, SU, US, TU, UT, RU, UR, USU, UTU, URU) was selected
- 3 M, N, G Must be selected if pneumatic valve manifold supply (6) S or V was selected
- 4 Z A reversible pressure zone cannot be terminated with a right-hand end plate (4) V, Y, U (internal pilot air supply)

Ordering Data – Configurable Products



Valve Manifolds Type 45 VTSA-F, G Thread for CPX – Pneumatic Part

→ 0 Options →

Pneumatic manifold subbases 00 ... 15

11 Type of interlinking block: A, B, E, F, AK, BK, EK, FK
 12 Compressed air supply/duct separation: S, T, R, U, SU, US, TU, UT, RU, UR, USU, UTU, URU
 13 Reverse operation: Z

Module position

00	01	02	03	04	05	06	07	08	09	10	11	12	13	14	15
A	B	B	BS	B											

11 + 12 + 13

Ordering Table		18 mm	26 mm	Conditions	Code	Enter code	
11	Pneumatic manifold subbases			5	-	-	
0	Type of interlinking block 00 ... 15	Manifold subbase	2 valve positions, 4 addresses	-	A	Enter the equipment selected in the order code	
			-	2 valve positions, 4 addresses	B		
			2 valve positions, 2 addresses	-	6		E
			-	2 valve positions, 2 addresses	6		F
	Manifold subbase with QS push-in fittings, small	2 valve positions, 4 addresses	-	7	AK		
		-	2 valve positions, 4 addresses	7	BK		
		2 valve positions, 2 addresses	-	8	EK		
		-	2 valve positions, 2 addresses	8	FK		
12	Compressed air supply/duct separation 00 ... 15	Duct separation 1, 3, 5		9 10	S		
		Duct separation 1		9 10	T		
		Duct separation 3, 5		9 10	R		
		Supply plate			U		
		Supply plate with duct separation 1, 3, 5 at left		9	SU		
		Supply plate with duct separation 1, 3, 5 at right		9	US		
		Supply plate with duct separation 1 at left		9	TU		
		Supply plate with duct separation 1 at right		9	UT		
		Supply plate with duct separation 3, 5 at left		9	RU		
		Supply plate with duct separation 3, 5 at right		9	UR		
		2 supply plates with duct separation 1, 3, 5 in centre			USU		
		2 supply plates with duct separation 1 in centre			UTU		
2 supply plates with duct separation 3, 5 in centre			URU				
13	Reverse operation 00 ... 15	Subsequent valve positions permitted for reverse operation		11	Z		

- 5 Manifold subbases must be fitted throughout without any gaps
- 6 E, F Only with valves (14) M, O and L
- 7 AK, BK Only with configuration of all pneumatic connections (7) N or G
- 8 EK, FK Only with configuration of all pneumatic connections (7) N or G
Only with valves (14) M, O and L

- 9 S, T, R, SU, US, TU, UT, RU, UR No pressure-free zones may be created
- 10 S, T, R Cannot be selected on last manifold subbase
- 11 Z Only with compressed air supply/duct separation (12) S, SU, US or USU.
A reversible pressure zone cannot be terminated with a right-hand end plate (4) V, Y, U

Ordering Data – Configurable Products



Valve Manifolds Type 45 VTSA-F, G Thread for CPX – Pneumatic Part

→ 0 Options →

Pneumatic valve positions 00 ... 31

- 14 Valve position 00 ... 31: M, O, J, D, N, K, H, B, G, E, P, Q, R, L
- 15 Pressure regulator for position 00 ... 31: ZA, ZB, ZC, ZD, ZE, ZK, ZL, ZF, ZG, ZH, ZI, ZJ, ZM, ZN
- 16 Pressure indicator for position 00 ... 31: T, U
- 17 Flow control valve position 00 ... 31: X
- 18 Vertical pressure isolating plate for position 00 ... 31: ZT
- 19 Vertical supply plate for position 00 ... 31: ZU

Valve position		19 Vertical supply plate for position 00 ... 31: ZU																					
00	01	02	03	04	05	06	07	08	09	10	11	12	13	14	15	16	17	18	19	20	...	30	31
M	M	M	O	O	O	J	J	E	E												...		

14 + 15 + 16 + 17 + 18 + 19

Ordering table		18 mm	26 mm	Conditions	Code	Enter code
14	Pneumatic valve positions 00 ... 31				-	-
0	Valve position 00 ... 31	5/2-way valve, single solenoid with pneumatic spring return			M	Enter equipment selection for valve positions in order code
		5/2-way valve, single solenoid with spring return			O	
		5/2-way valve, double solenoid			J	
		5/2-way valve, double solenoid with dominant signal			D	
		2x 3/2-way valve, normally open	12		N	
		2x 3/2-way valve, normally closed	12		K	
		2x 3/2-way valve, 1x normally closed, 1x normally open	12		H	
		5/3-way valve, mid-position pressurised			B	
		5/3-way valve, mid-position closed			G	
		5/3-way valve, mid-position exhausted			E	
		2x 3/2-way valve, normally open, reverse operation	13		P	
		2x 3/2-way valve, normally closed, reverse operation	13		Q	
		2x 3/2-way valve, 1x normally closed, 1x normally open, reverse operation	13		R	
		Vacant position			L	
15	Pressure regulator for valve position 00 ... 31	Input pressure 10 bar	Pressure regulator plate for port 1	14	ZA	
			Pressure regulator plate for port 4		ZB	
			Pressure regulator plate for port 2		ZC	
			Pressure regulator plate for port 4/2		ZD	
			Pressure regulator plate for port 4/2, reversible	15	ZE	
			Pressure regulator plate for port 4, reversible	15	ZK	
			Pressure regulator plate for port 2, reversible	15	ZL	
		Input pressure 6 bar	Pressure regulator plate for port 1	14	ZF	
			Pressure regulator plate for port 4		ZG	
			Pressure regulator plate for port 2		ZH	
			Pressure regulator plate for port 4/2		ZI	
			Pressure regulator plate for port 4/2, reversible	15	ZJ	
			Pressure regulator plate for port 4, reversible	15	ZM	
			Pressure regulator plate for port 2, reversible	15	ZN	

- 12 N, K, H Not permitted in zones with reverse operation. Not with pressure regulator (15) ZE, ZJ (reversible pressure regulator plate)
- 13 P, Q, R Only permissible in zones with reverse operation or with pressure regulator (15) ZE, ZJ (reversible pressure regulator plate). Pilot pressure required on duct 12 (ducted exhaust air not possible). Not with right-hand end plate (4) Y, Z

- 14 ZA, ZF Not permitted in zones with reverse operation.
- 15 ZE, ZK, ZL, ZJ, ZM, ZN Not permitted in zones with reverse operation. Not with 2x 3/2-way valves (14) N, K, H

Ordering Data – Configurable Products

Valve Manifolds Type 45 VTSA-F, G Thread for CPX – Pneumatic Part

➔ **0 Options**

Pneumatic accessories

U, ...B, ...T, ...N, ...V

+ **10N**
20

Ordering Table						
Width	18 mm	26 mm	Conditions	Code	Enter code	
▼ 0	16 Pressure indicator for valve position 00 ... 31	Pressure gauge, 10 bar	16	T	Enter equipment selection for valve positions in order code	
		Pressure gauge, 6 bar	17	U		
	17 Flow control valve for valve position 00 ... 31	Flow control plate	18	X		
	18 Vertical isolating plate for valve position 00 ... 31	Pressure separator plate on valve assembly	19	ZT		
	19 Vertical supply plate for valve position 00 ... 31	Compressed air supply on valve	18	ZU		
	20 Pneumatic accessories			+		+
	Mounting brackets (pack of 5)	Supplied separately	20	U		
	Inscription label holder for valves	5 ... 50		...B		
	Inscription label holder for manifold subbases	5 ... 50		...T		
	Cover cap for manual override, pushing	10 ... 90		...N		
Cover cap for manual override, covered	10 ... 90		...V			

- 16 T** Only with pressure regulator (15) ZA, ZB, ZC, ZD, ZE
- 17 U** Only with pressure regulator (15) ZF, ZG, ZH, ZI, ZJ
- 18 X, ZU** Not with valves with reverse operation (14) P, Q, R

- 19 ZT** Not with right-hand end plate (4) Y, Z
- 20 U** Can only be selected if there are more than 9 valve positions. Cannot be combined with DIN H-rail

Ordering Data – Configurable Products

Valve Manifolds Type 45 VTSA-F, G Thread – Pneumatic Part

FESTO

Sizes of Pneumatic Connections					
		Code	Duct	Width	
				18 mm	26 mm
7		Configuration of all pneumatic connections			
4	Right-hand end plate V, X, Y, U, Z, W	M	12, 14	G $\frac{1}{4}$ (QS-G $\frac{1}{4}$ -10)	G $\frac{1}{4}$ (QS-G $\frac{1}{4}$ -10)
		G	12, 14	G $\frac{1}{4}$ (QS-G $\frac{1}{4}$ -10)	G $\frac{1}{4}$ (QS-G $\frac{1}{4}$ -10)
		N	12, 14	G $\frac{1}{4}$ (QS-G $\frac{1}{4}$ -8)	G $\frac{1}{4}$ (QS-G $\frac{1}{4}$ -8)
4	Right-hand end plate V, X, U	M	1, 3, 5	G $\frac{1}{2}$ (QS-G $\frac{1}{2}$ -16)	G $\frac{1}{2}$ (QS-G $\frac{1}{2}$ -16)
		G	1, 3, 5	G $\frac{1}{2}$ (QS-G $\frac{1}{2}$ -16)	G $\frac{1}{2}$ (QS-G $\frac{1}{2}$ -16)
		N	1, 3, 5	G $\frac{1}{2}$ (QS-G $\frac{1}{2}$ -12)	G $\frac{1}{2}$ (QS-G $\frac{1}{2}$ -12)
9	Left-hand supply plate X	M	1, 3, 5	G $\frac{1}{2}$ (QS-G $\frac{1}{2}$ -16)	G $\frac{1}{2}$ (QS-G $\frac{1}{2}$ -16)
		G	1, 3, 5	G $\frac{1}{2}$ (QS-G $\frac{1}{2}$ -16)	G $\frac{1}{2}$ (QS-G $\frac{1}{2}$ -16)
		N	1, 3, 5	G $\frac{1}{2}$ (QS-G $\frac{1}{2}$ -12)	G $\frac{1}{2}$ (QS-G $\frac{1}{2}$ -12)
11	Type of interlinking block Large A, B, E, F	M	2, 4	G $\frac{1}{8}$ (QS-G $\frac{1}{8}$ -8)	G $\frac{1}{4}$ (QS-G $\frac{1}{4}$ -10)
11	Type of interlinking block Small AK, BK, EK, FK	N	2, 4	G $\frac{1}{8}$ (QS-G $\frac{1}{8}$ -6)	G $\frac{1}{4}$ (QS-G $\frac{1}{4}$ -8)

Ordering Data – Individual Valve

Valve Manifolds Type 44 VTSA, Type 45 VTSA-F – Metric Series



Ordering Data					
	Code	Valve function	Width	Type	Part No.
Solenoid valves, 24 V DC					
	M	5/2-way valve, single solenoid, pneumatic spring return	18 mm	VSVA-B-M52-AZD-A2-1T1L	539184
			26 mm	VSVA-B-M52-AZD-A1-1T1L	539158
			42 mm ¹⁾	VSVA-B-M52-AZD-D1-1T1L	543698
	O	5/2-way valve, single solenoid, spring return	18 mm	VSVA-B-M52-MZD-A2-1T1L	539185
			26 mm	VSVA-B-M52-MZD-A1-1T1L	539159
			42 mm ¹⁾	VSVA-B-M52-MZD-D1-1T1L	543699
	J	5/2-way valve, double solenoid, bistable	18 mm	VSVA-B-B52-ZD-A2-1T1L	539182
			26 mm	VSVA-B-B52-ZD-A1-1T1L	539156
			42 mm ¹⁾	VSVA-B-B52-ZD-D1-1T1L	543696
	D	5/2-way valve, double solenoid, dominant signal	18 mm	VSVA-B-D52-ZD-A2-1T1L	539183
			26 mm	VSVA-B-D52-ZD-A1-1T1L	539157
			42 mm ¹⁾	VSVA-B-D52-ZD-D1-1T1L	543697
	N	2x 3/2-way valve, single solenoid, normally open	18 mm	VSVA-B-T32U-AZD-A2-1T1L	539178
			26 mm	VSVA-B-T32U-AZD-A1-1T1L	539152
			42 mm ¹⁾	VSVA-B-T32U-AZD-D1-1T1L	543692
	K	2x 3/2-way valve, single solenoid, normally closed	18 mm	VSVA-B-T32C-AZD-A2-1T1L	539176
			26 mm	VSVA-B-T32C-AZD-A1-1T1L	539150
			42 mm ¹⁾	VSVA-B-T32C-AZD-D1-1T1L	543690
	H	2x 3/2-way valve, single solenoid, 1x normally open, 1x normally closed	18 mm	VSVA-B-T32H-AZD-A2-1T1L	539180
			26 mm	VSVA-B-T32H-AZD-A1-1T1L	539154
			42 mm ¹⁾	VSVA-B-T32H-AZD-D1-1T1L	543694
	B	5/3-way valve, mid-position pressurised	18 mm	VSVA-B-P53U-ZD-A2-1T1L	539186
			26 mm	VSVA-B-P53U-ZD-A1-1T1L	539160
			42 mm ¹⁾	VSVA-B-P53U-ZD-D1-1T1L	543700
	G	5/3-way valve, mid-position closed	18 mm	VSVA-B-P53C-ZD-A2-1T1L	539188
			26 mm	VSVA-B-P53C-ZD-A1-1T1L	539162
			42 mm ¹⁾	VSVA-B-P53C-ZD-D1-1T1L	543702
	E	5/3-way valve, mid-position exhausted	18 mm	VSVA-B-P53E-ZD-A2-1T1L	539187
			26 mm	VSVA-B-P53E-ZD-A1-1T1L	539161
			42 mm ¹⁾	VSVA-B-P53E-ZD-D1-1T1L	543701
	P	2x 3/2-way valve, single solenoid, reverse operation, normally open	18 mm	VSVA-B-T32F-AZD-A2-1T1L	539179
			26 mm	VSVA-B-T32F-AZD-A1-1T1L	539153
			42 mm ¹⁾	VSVA-B-T32F-AZD-D1-1T1L	543693
	Q	2x 3/2-way valve, single solenoid, reverse operation, normally closed	18 mm	VSVA-B-T32N-AZD-A2-1T1L	539177
			26 mm	VSVA-B-T32N-AZD-A1-1T1L	539151
			42 mm ¹⁾	VSVA-B-T32N-AZD-D1-1T1L	543691
	R	2x 3/2-way valve, single solenoid, reverse operation, 1x normally open, 1x normally closed	18 mm	VSVA-B-T32W-AZD-A2-1T1L	539181
			26 mm	VSVA-B-T32W-AZD-A1-1T1L	539155
			42 mm ¹⁾	VSVA-B-T32W-AZD-D1-1T1L	543695

1) Type 44 VTSA only

Ordering Data – Individual Valve

Valve Manifolds Type 44 VTSA, Type 45 VTSA-F – Metric Series



Ordering Data					
	Code	Valve function	Width	Type	Part No.
Solenoid valves, 110 V AC					
	M	5/2-way valve, single solenoid, pneumatic spring return	18 mm	VSVA-B-M52-AZD-A2-2AT1L	539171
			26 mm	VSVA-B-M52-AZD-A1-2AT1L	539145
			42 mm ¹⁾	VSVA-B-M52-AZD-D1-2AT1L	543685
	O	5/2-way valve, single solenoid, spring return	18 mm	VSVA-B-M52-MZD-A2-2AT1L	539172
			26 mm	VSVA-B-M52-MZD-A1-2AT1L	539146
			42 mm ¹⁾	VSVA-B-M52-MZD-D1-2AT1L	543686
	J	5/2-way valve, double solenoid, bistable	18 mm	VSVA-B-B52-ZD-A2-2AT1L	539169
			26 mm	VSVA-B-B52-ZD-A1-2AT1L	539143
			42 mm ¹⁾	VSVA-B-B52-ZD-D1-2AT1L	543683
	D	5/2-way valve, double solenoid, dominant signal	18 mm	VSVA-B-D52-ZD-A2-2AT1L	539170
			26 mm	VSVA-B-D52-ZD-A1-2AT1L	539144
			42 mm ¹⁾	VSVA-B-D52-ZD-D1-2AT1L	543684
	N	2x 3/2-way valve, single solenoid, normally open	18 mm	VSVA-B-T32U-AZD-A2-2AT1L	539165
			26 mm	VSVA-B-T32U-AZD-A1-2AT1L	539139
			42 mm ¹⁾	VSVA-B-T32U-AZD-D1-2AT1L	543679
	K	2x 3/2-way valve, single solenoid, normally closed	18 mm	VSVA-B-T32C-AZD-A2-2AT1L	539163
			26 mm	VSVA-B-T32C-AZD-A1-2AT1L	539137
			42 mm ¹⁾	VSVA-B-T32C-AZD-D1-2AT1L	543677
	H	2x 3/2-way valve, single solenoid, 1x normally open, 1x normally closed	18 mm	VSVA-B-T32H-AZD-A2-2AT1L	539167
			26 mm	VSVA-B-T32H-AZD-A1-2AT1L	539141
			42 mm ¹⁾	VSVA-B-T32H-AZD-D1-2AT1L	543681
	B	5/3-way valve, mid-position pressurised	18 mm	VSVA-B-P53U-ZD-A2-2AT1L	539173
			26 mm	VSVA-B-P53U-ZD-A1-2AT1L	539147
			42 mm ¹⁾	VSVA-B-P53U-ZD-D1-2AT1L	543687
	G	5/3-way valve, mid-position closed	18 mm	VSVA-B-P53C-ZD-A2-2AT1L	539175
			26 mm	VSVA-B-P53C-ZD-A1-2AT1L	539149
			42 mm ¹⁾	VSVA-B-P53C-ZD-D1-2AT1L	543689
	E	5/3-way valve, mid-position exhausted	18 mm	VSVA-B-P53E-ZD-A2-2AT1L	539174
			26 mm	VSVA-B-P53E-ZD-A1-2AT1L	539148
			42 mm ¹⁾	VSVA-B-P53E-ZD-D1-2AT1L	543688
	P	2x 3/2-way valve, single solenoid, reverse operation, normally open	18 mm	VSVA-B-T32F-AZD-A2-2AT1L	539166
			26 mm	VSVA-B-T32F-AZD-A1-2AT1L	539140
			42 mm ¹⁾	VSVA-B-T32F-AZD-D1-2AT1L	543680
	Q	2x 3/2-way valve, single solenoid, reverse operation, normally closed	18 mm	VSVA-B-T32N-AZD-A2-2AT1L	539164
			26 mm	VSVA-B-T32N-AZD-A1-2AT1L	539138
			42 mm ¹⁾	VSVA-B-T32N-AZD-D1-2AT1L	543678
	R	2x 3/2-way valve, single solenoid, reverse operation, 1x normally open, 1x normally closed	18 mm	VSVA-B-T32W-AZD-A2-2AT1L	539168
			26 mm	VSVA-B-T32W-AZD-A1-2AT1L	539142
			42 mm ¹⁾	VSVA-B-T32W-AZD-D1-2AT1L	543682

1) Type 44 VTSA only

Accessories

Valve Manifolds Type 44 VTSA, Type 45 VTSA-F – Metric Series

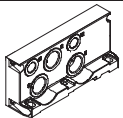
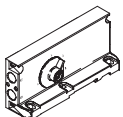
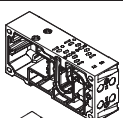
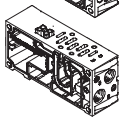
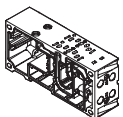
Ordering Data					
Designation	Code	Description	Width	Type	Part No.
Right-hand end plate					
	V	With supply air/exhaust air, internal pilot air supply, G $\frac{1}{2}$		VABE-S6-1R-G12	539234
	X	With supply air/exhaust air, external pilot air supply, G $\frac{1}{2}$		VABE-S6-1RZ-G12	539236
End plate with pilot air selector					
	Y	Internal pilot air supply		VABE-S6-1RZ-G-B1	539238
	U	Internal pilot air supply, ducted pilot exhaust air			
	Z	External pilot air supply			
	W	External pilot air supply, ducted pilot exhaust air			
Manifold subbase, port pattern to ISO 15407-2 and ISO 5599-2 – Type 44 VTSA					
 	A	2 valve positions, 4 addresses, for double solenoid valves	18 mm	VABV-S4-2S-G18-2T2	539224
	B	2 valve positions, 4 addresses, for double solenoid valves	26 mm	VABV-S4-1S-G14-2T2	539220
	C	1 valve position, 2 addresses, for double solenoid valves	42 mm	VABV-S2-1S-G38-T2	542458
	E	2 valve positions, 2 addresses, for single solenoid valves	18 mm	VABV-S4-2S-G18-2T1	539226
	F	2 valve positions, 2 addresses, for single solenoid valves	26 mm	VABV-S4-1S-G14-2T1	539222
	G	1 valve position, 1 address, for single solenoid valves	42 mm	VABV-S2-1S-G38-T1	542459
	Manifold subbase, optimized for flow rate – Type 45 VTSA-F				
	A	2 valve positions, 4 addresses, for double solenoid valves	18 mm	VABV-S4-2HS-G18-2T2	546215
	B	2 valve positions, 4 addresses, for double solenoid valves	26 mm	VABV-S4-1HS-G14-2T2	546211
	E	2 valve positions, 2 addresses, for single solenoid valves	18 mm	VABV-S4-2HS-G18-2T1	546214
	F	2 valve positions, 2 addresses, for single solenoid valves	26 mm	VABV-S4-1HS-G14-2T1	546210

Accessories

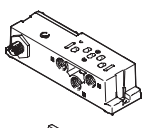
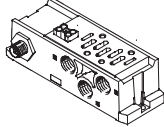
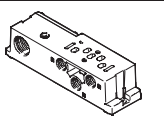
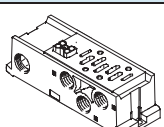
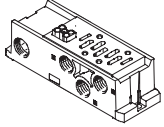

Valve Manifolds Type 44 VTSA – Metric Series

FESTO

Ordering Data						
Designation	Code	Description	Width	Type	Part No.	
Individual subbase, port pattern to ISO 15407-2 and ISO 5599-2, electrical connection with plug connector M12 – Type 44 VTSA						
	Threaded connection, internal pilot air supply					
	–	Connections at side, G $\frac{1}{8}$	18 mm	VABS-S4-2S-G18-B-R3	541070	
	–	Connections at side, G $\frac{1}{4}$	26 mm	VABS-S4-1S-G14-B-R3	541069	
	–	Connections at side, G $\frac{3}{8}$	42 mm	VABS-S2-1S-G38-B-R3	546104	
		Threaded connection, external pilot air supply				
		–	Connections at side, G $\frac{1}{8}$	18 mm	VABS-S4-2S-G18-R3	541064
–		Connections at side, G $\frac{1}{4}$	26 mm	VABS-S4-1S-G14-R3	541063	
–		Connections at side, G $\frac{3}{8}$	42 mm	VABS-S2-1S-G38-R3	546101	
Individual subbase, port pattern to ISO 15407-2, electrical connection with cable manifolds – Type 44 VTSA						
	Threaded connection, internal pilot air supply					
	–	Connections at side, G $\frac{1}{8}$	18 mm	VABS-S4-2S-G18-B-K2	541067	
	–	Connections at side, G $\frac{1}{4}$	26 mm	VABS-S4-1S-G14-B-K2	541065	
	Threaded connection, external pilot air supply	–	Connections at side, G $\frac{1}{8}$	18 mm	VABS-S4-2S-G18-K2	539723
		–	Connections at side, G $\frac{1}{4}$	26 mm	VABS-S4-1S-G14-K2	539725
Individual subbase, port pattern to ISO 5599-2, electrical connection with spring-loaded manifold – Type 44 VTSA						
	Threaded connection, internal pilot air supply					
	–	Connections at side, G $\frac{3}{8}$	42 mm	VABS-S2-1S-G38-B-C1	546762	
	Threaded connection, external pilot air supply					
		–	Connections at side, G $\frac{3}{8}$	42 mm	VABS-S2-1S-G38-C1	546760
Individual subbase, port pattern to ISO 5599-2, electrical connection for self-assembly – Type 44 VTSA						
	Threaded connection, internal pilot air supply					
	–	Connections at side, G $\frac{3}{8}$	42 mm	VABS-S2-1S-G38-B-K1	546102	
	Threaded connection, external pilot air supply					
		–	Connections at side, G $\frac{3}{8}$	42 mm	VABS-S2-1S-G38-K1	546099

Accessories

Valve Manifolds Type 44 VTSA, Type 45 VTSA-F – Metric Series

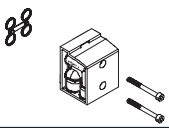
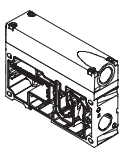
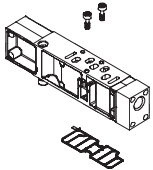
Ordering Data					
Designation	Code	Description	Width	Type	Part No.
Separator plate					
	S	Duct separation 1, 3, 5		VABD-S6-10-P3-C	539228
	T	Duct separation 1		VABD-S6-10-P1-C	539227
	R	Duct separation 3, 5		VABD-S6-10-P2-C	539229
90° connection plate					
	P	Outlet at bottom, connecting thread G $\frac{1}{8}$	18 mm	VABF-S4-2-A2G2-G18	539719
	P	Outlet at bottom, connecting thread G $\frac{1}{4}$	26 mm	VABF-S4-1-A2G2-G14	539721
	P	Outlet at bottom, connecting thread G $\frac{3}{8}$	42 mm ¹⁾	VABF-S2-1-A1G2-G38	546097
Supply plate					
	L	With exhaust plate, 3/5 common, G $\frac{1}{2}$		VABF-S6-10-P1A7-G12	539231
	K	With exhaust port cover, 3/5 separated, G $\frac{1}{2}$		VABF-S6-10-P1A6-G12	539230
Vertical supply plate					
	ZU	Connecting thread G $\frac{1}{8}$	18 mm	VABF-S4-2-P1A3-G18	540173
		Connecting thread G $\frac{1}{4}$	26 mm	VABF-S4-1-P1A3-G14	540171
		Connecting thread G $\frac{3}{8}$	42 mm ¹⁾	VABF-S2-1-P1A3-G38	546093

1) Type 44 VTSA only

Accessories

Valve Manifolds Type 44 VTSA, Type 45 VTSA-F – Metric Series





Ordering Data					
Designation	Code	Description	Width	Type	Part No.
Regulator plate					
	ZA	For port 1, 10 bar	18 mm	VABF-S4-2-R1C2-C-10	540153
		For port 1, 10 bar	26 mm	VABF-S4-1-R1C2-C-10	540154
		For port 1, 10 bar	42 mm ¹⁾	VABF-S2-1-R1C2-C-10	546084
	ZF	For port 1, 6 bar	18 mm	VABF-S4-2-R1C2-C-6	540151
		For port 1, 6 bar	26 mm	VABF-S4-1-R1C2-C-6	540152
		For port 1, 6 bar	26 mm	VABF-S4-1-R1C2-C-6E	549876
		For port 1, 6 bar	42 mm ¹⁾	VABF-S2-1-R1C2-C-6	546083
	ZB	For port 4, 10 bar	18 mm	VABF-S4-2-R3C2-C-10	540157
		For port 4, 10 bar	26 mm	VABF-S4-1-R3C2-C-10	540158
		For port 4, 10 bar	42 mm ¹⁾	VABF-S2-1-R3C2-C-10	546086
	ZG	For port 4, 6 bar	18 mm	VABF-S4-2-R3C2-C-6	540155
		For port 4, 6 bar	26 mm	VABF-S4-1-R3C2-C-6	540156
		For port 4, 6 bar	42 mm ¹⁾	VABF-S2-1-R3C2-C-6	546085
	ZC	For port 2, 10 bar	18 mm	VABF-S4-2-R2C2-C-10	540161
		For port 2, 10 bar	26 mm	VABF-S4-1-R2C2-C-10	540162
		For port 2, 10 bar	42 mm ¹⁾	VABF-S2-1-R2C2-C-10	546088
	ZH	For port 2, 6 bar	18 mm	VABF-S4-2-R2C2-C-6	540159
		For port 2, 6 bar	26 mm	VABF-S4-1-R2C2-C-6	540160
		For port 2, 6 bar	42 mm ¹⁾	VABF-S2-1-R2C2-C-6	546087
	ZD	For ports 2 and 4, 10 bar	18 mm	VABF-S4-2-R4C2-C-10	540165
		For ports 2 and 4, 10 bar	26 mm	VABF-S4-1-R4C2-C-10	540166
		For ports 2 and 4, 10 bar	42 mm ¹⁾	VABF-S2-1-R4C2-C-10	546090
	ZI	For ports 2 and 4, 6 bar	18 mm	VABF-S4-2-R4C2-C-6	540163
		For ports 2 and 4, 6 bar	26 mm	VABF-S4-1-R4C2-C-6	540164
		For ports 2 and 4, 6 bar	42 mm ¹⁾	VABF-S2-1-R4C2-C-6	546089
	ZE	For ports 2 and 4, reversible, 10 bar	18 mm	VABF-S4-2-R5C2-C-10	540169
		For ports 2 and 4, reversible, 10 bar	26 mm	VABF-S4-1-R5C2-C-10	540170
		For ports 2 and 4, reversible, 10 bar	42 mm ¹⁾	VABF-S2-1-R5C2-C-10	546092
	ZJ	For ports 2 and 4, reversible, 6 bar	18 mm	VABF-S4-2-R5C2-C-6	540167
		For ports 2 and 4, reversible, 6 bar	26 mm	VABF-S4-1-R5C2-C-6	540168
		For ports 2 and 4, reversible, 6 bar	42 mm ¹⁾	VABF-S2-1-R5C2-C-6	546091
	ZL	For port 2, reversible, 10 bar	18 mm	VABF-S4-2-R6C2-C-10	546252
		For port 2, reversible, 10 bar	26 mm	VABF-S4-1-R6C2-C-10	546251
		For port 2, reversible, 10 bar	42 mm ¹⁾	VABF-S2-1-R6C2-C-10	546832
	ZN	For port 2, reversible, 6 bar	18 mm	VABF-S4-2-R6C2-C-6	546248
		For port 2, reversible, 6 bar	26 mm	VABF-S4-1-R6C2-C-6	546247
For port 2, reversible, 6 bar		42 mm ¹⁾	VABF-S2-1-R6C2-C-6	546831	
ZK	For port 4, reversible, 10 bar	18 mm	VABF-S4-2-R7C2-C-10	546254	
	For port 4, reversible, 10 bar	26 mm	VABF-S4-1-R7C2-C-10	546253	
	For port 4, reversible, 10 bar	42 mm ¹⁾	VABF-S2-1-R7C2-C-10	546834	
ZM	For port 4, reversible, 6 bar	18 mm	VABF-S4-2-R7C2-C-6	546250	
	For port 4, reversible, 6 bar	26 mm	VABF-S4-1-R7C2-C-6	546249	
	For port 4, reversible, 6 bar	42 mm ¹⁾	VABF-S2-1-R7C2-C-6	546833	

1) Type 44 VTSA only

Accessories

Valve Manifolds Type 44 VTSA, Type 45 VTSA-F – Metric Series

FESTO

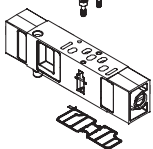
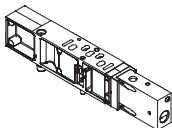
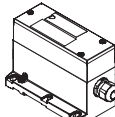
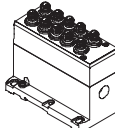
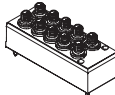
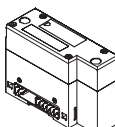
Ordering Data					
Designation	Code	Description	Width	Type	Part No.
Pressure gauge					
	T	With cartridge connection for regulator, 10 bar for regulator plate, code ZA, ZB, ZC, ZD, ZE	18 mm	PAGN-26-16-P10	543487
			26 mm		
			42 mm ¹⁾		
	U	With cartridge connection for regulator, 6 bar for regulator plate, code ZF, ZG, ZH, ZI, ZJ	18 mm	PAGN-26-10-P10	543488
			26 mm		
			42 mm ¹⁾		
Cartridge for regulator plate					
	-	For tubing O.D. 4 mm		QSP10-4	172972
	-	For tubing O.D. 3/16"		QSP10-3/16U	172975
Flow control plate					
	X	Controls the flow of exhaust air after the valve to ducts 3 and 5	18 mm	VABF-S4-2-F1B1-C	540176
			26 mm	VABF-S4-1-F1B1-C	540175
			42 mm ¹⁾	VABF-S2-1-F1B1-C	546095
Vertical shut-off plate					
	ZT	2/2-way valve for shutting off the operating pressure at the valve position	18 mm	VABF-S4-2-L1D1-C	542884
			26 mm	VABF-S4-1-L1D1-C	542885
			42 mm ¹⁾	VABF-S2-1-L1D1-C	546096
Multi-pin node					
	T	Tension spring, for threaded connection, 36-pin		VABE-S6-1LF-C-M1-C36M	543412
	MP1	Sub-D plug, 37-pin		VABE-S6-1LT-C-M1-S37	543414
Individual electrical connection					
	-MP2	Multi-pin node with individual connection M12, 6-way		VABE-S6-LT-C-S6-R5	549046
	-MP3	Multi-pin node with individual connection M12, 10-way		VABE-S6-LT-C-S10-R5	549047
	-	Cover for individual connection M12, 6-way		VAEM-S6-C-S6-R5	549048
	-	Cover for individual connection M12, 10-way		VAEM-S6-C-S10-R5	549049
Pneumatic interface					
	-	For electrical manifold CPX		VABA-S6-1-X1	543416

1) Type 44 VTSA only

Accessories

Valve Manifolds Type 44 VTSA, Type 45 VTSA-F – Metric Series







FESTO

Ordering Data						
Designation	Code	Description	Type	Part No.		
Connecting cable with Sub-D plug socket						
	Polyurethane, IP65					
	GA	Connecting cable for max. 8 solenoid coils, 10-pin, suitable for chain link trunking	2.5 m	NEBV-S1W37-E-2,5-LE10	539240	
	GB		5 m	NEBV-S1W37-E-5-LE10	539241	
	GC		10 m	NEBV-S1W37-E-10-LE10	539242	
	GD	Connecting cable for max. 22 solenoid coils, 26-pin, suitable for chain link trunking	2.5 m	NEBV-S1W37-E-2,5-LE26	539243	
	GE		5 m	NEBV-S1W37-E-5-LE26	539244	
	GF		10 m	NEBV-S1W37-E-10-LE26	539245	
	GG	Connecting cable for max. 32 solenoid coils, 37-pin	2.5 m	NEBV-S1W37-K-2,5-LE37	539246	
	GH		5 m	NEBV-S1W37-K-5-LE37	539247	
	GI		10 m	NEBV-S1W37-K-10-LE37	539248	
	Polyvinyl chloride, IP65					
	GK	Connecting cable for max. 8 solenoid coils, 10-pin	2.5 m	NEBV-S1W37-KM-2,5-LE10	543271	
	GL		5 m	NEBV-S1W37-KM-5-LE10	543272	
	GM		10 m	NEBV-S1W37-KM-10-LE10	543273	
	GN	Connecting cable for max. 22 solenoid coils, 27-pin	2.5 m	NEBV-S1W37-KM-2,5-LE27	543274	
	GO		5 m	NEBV-S1W37-KM-5-LE27	543275	
	GP		10 m	NEBV-S1W37-KM-10-LE27	543276	
	GQ	Connecting cable for max. 32 solenoid coils, 37-pin	2.5 m	NEBV-S1W37-KM-2,5-LE37	543277	
	GR		5 m	NEBV-S1W37-KM-5-LE37	543278	
GS	10 m		NEBV-S1W37-KM-10-LE37	543279		

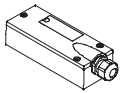
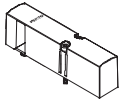
Accessories

Valve Manifolds Type 44 VTSA, Type 45 VTSA-F – Metric Series

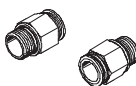
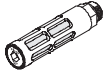

FESTO

Ordering Data					
Designation	Code	Description	Type	Part No.	
Cover for multi-pin plug					
	–	For user configuration	NECV-S1W37	545974	
Cover					
	L	Blanking plate for vacant position	18 mm	VABB-S4-2-WT	539213
			26 mm	VABB-S4-1-WT	539212
			42 mm	VABB-S2-1-WT	543186
	N	Cover cap for manual override, pushing	10 pieces	VAMC-S6-CH	541010
	V	Cover cap for manual override, covered	10 pieces	VAMC-S6-CS	541011
	–	End cap for electrical manifold module, size 18 mm and 26 mm	10 pieces	VABD-S4-E-C	547713
Inscription label holder					
	B	Clip-on inscription label holder for valve cap	5 pieces	ASCF-T-S6	540888
	T	Inscription label holder for manifold blocks	5 pieces	ASCF-M-S6	540889
Push-in fitting					
	–	Connecting thread G $\frac{1}{4}$ for tubing O.D. 10 mm	10 pieces	QS-G $\frac{1}{4}$ -10	186101
		Connecting thread G $\frac{1}{4}$ for tubing O.D. 8 mm	10 pieces	QS-G $\frac{1}{4}$ -8	186099
		Connecting thread G $\frac{1}{8}$ for tubing O.D. 10 mm	10 pieces	QS-G $\frac{1}{8}$ -10	190643
		Connecting thread G $\frac{1}{8}$ for tubing O.D. 8 mm	10 pieces	QS-G $\frac{1}{8}$ -8	186098
		Connecting thread G $\frac{1}{8}$ for tubing O.D. 6 mm	10 pieces	QS-G $\frac{1}{8}$ -6	186096
		Connecting thread G $\frac{1}{2}$ for tubing O.D. 16 mm	1 piece	QS-G $\frac{1}{2}$ -16	186105
		Connecting thread G $\frac{3}{8}$ for tubing O.D. 10 mm	10 pieces	QS-G $\frac{3}{8}$ -10	186102
		Connecting thread G $\frac{3}{8}$ for tubing O.D. 12 mm	10 pieces	QS-G $\frac{3}{8}$ -12	186103
Silencer					
	–	Connecting thread G $\frac{1}{4}$		U- $\frac{1}{4}$	2316
	L	Connecting thread G $\frac{1}{2}$		U- $\frac{1}{2}$	2310
	K	Connecting thread G $\frac{1}{2}$		U- $\frac{1}{2}$ -B	6844

Accessories

FESTO

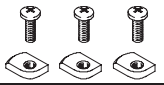
Valve Manifolds Type 44 VTSA, Type 45 VTSA-F – Metric Series

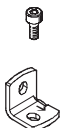
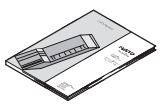
Ordering Data					
Designation	Code	Description	Type	Part No.	
Blanking plug					
	Threaded connection				
	-	Thread G $\frac{1}{8}$	10 pieces	B- $\frac{1}{8}$	3568
	-	Thread G $\frac{1}{4}$	10 pieces	B- $\frac{1}{4}$	3569
DIN H-rail mounting					
	-	VTSA/VTSA-F with fieldbus	3 pieces	CPX-CPA-BG-NRH	526032
		VTSA/VTSA-F with multi-pin plug	2 pieces	CPA-BG-NRH	173498
Wall mounting					
	U	Mounting bracket		VAME-S6-10-W	539214
User manual					
	D	User manual for valve manifold VTSA/VTSA-F	German	P.BE-VTSA-44-DE	538922
	E		English	P.BE-VTSA-44-EN	538923
	S		Spanish	P.BE-VTSA-44-ES	538924
	F		French	P.BE-VTSA-44-FR	538925
	I		Italian	P.BE-VTSA-44-IT	538926
	V		Swedish	P.BE-VTSA-44-SV	538927

Valve Manifolds Type 44 VTSA, Type 45 VTSA-F – Inch Series

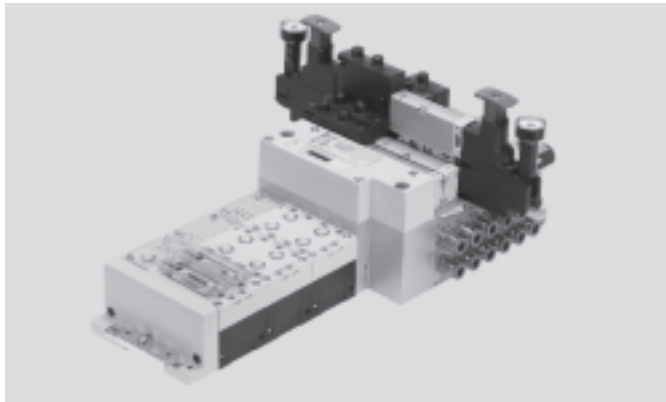

- Modular multi-functional valve manifold for up to 32 valves:
 - Type 44 VTSA, ISO 15407-2/ISO 5599-2
 - Type 45 VTSA-F with optimized flow
- Different valve sizes on one valve manifold:
 - 0.71 in (ISO 02)
 - 1.02 in (ISO 01)
 - 1.65 in (ISO 1), type 44 VTSA only
- Flow rate: up to 53.0 scfm
- Design suitable for electrical peripherals CPX

Product Range Overview														
Electrical connection	Valve types													
	5/2-way valve, single solenoid with pneumatic spring return	5/2-way valve, single solenoid with spring return	5/2-way valve, double solenoid	5/2-way valve, double solenoid dominant switching	2x 3/2-way valve, normally open	2x 3/2-way valve, normally closed	2x 3/2-way valve: 1x normally open, 1x normally closed	5/3-way valve, mid-position pressurised	5/3-way valve, mid-position closed	5/3-way valve, mid-position exhausted	2x 3/2-way valve, normally open, reverse operation	2x 3/2-way valve, normally closed, reverse operation	2x 3/2-way valve: 1x normally open, 1x normally closed, reverse operation	Blanking plate for vacant position
	M	O	J	D	N	K	H	B	G	F	P	Q	R	L
Electrical multi-pin plug connection, CageClamp	■	■	■	■	■	■	■	■	■	■	■	■	■	■
Electrical multi-pin plug connection, Sub-D (37-pin)	■	■	■	■	■	■	■	■	■	■	■	■	■	■
Fieldbus connection/control block	■	■	■	■	■	■	■	■	■	■	■	■	■	■

Features		Contents	
<p>Flexible</p> <ul style="list-style-type: none"> • Easy modification and expansion due to high degree of modularity. Fast connection of the subbases by means of four screws. • Fully modular system allows the combination of 0.71 in (Size 02), 1.02 in (Size 01) and 1.65 in (Size 1) valves on the same manifold without the need for any transition/adaptor plate. • Change direction of working ports with easy-to-install angle plate. • Fieldbus valve terminal suitable for CPX electrical peripherals. <p>Easily integrated</p> <ul style="list-style-type: none"> • Fieldbus nodes: Interbus, DeviceNet, Profibus DP, CANopen, CC-Link via CPX terminal 	<ul style="list-style-type: none"> • Ethernet: Modbus/TCP, EtherNet/IP, TCP/IP via CPX terminal • Full complement of CPX I/O modules • Expandable up to 32 solenoid coils • Integration of a wide range of function modules possible • Supply plates permit a flexible air supply and variable pressure zones <p>Comprehensive</p> <ul style="list-style-type: none"> • High-performance valves in a sturdy metal housing • Complete range of vertical sandwich components such as pressure regulators, flow control valve, individual pressure supply, shutoff plate (hot swap). • Standard air qualities: 40 micron filtration grade. Can be used with lubricated or non-lubricated air, and inert gases. 	<p>Installation and maintenance</p> <ul style="list-style-type: none"> • Manual override available, with momentary, locking, or hidden (non-accessible) options. • Ready-to-install unit, preassembled and tested • Durable, low cost identification by label holder on the valve or label holder on the subbase. • Secure wall mounting or DIN rail mounting • Fast troubleshooting thanks to LEDs on the valves and diagnosis via fieldbus. • Reliability of service thanks to valves that can be replaced easily and quickly. • Easy fault identification using CPX-MMI handheld diagnostic unit. 	<ul style="list-style-type: none"> Features and Benefits → 102 Overview → 103 Pneumatic Components → 117 Electrical Components → 135 Installation and Operation → 140 Technical Data → 144 Dimensional Drawings <ul style="list-style-type: none"> – Type 44 VTSA → 151 – Type 45 VTSA-F → 161 Ordering Data <ul style="list-style-type: none"> – Type 44 VTSA → 168 – Type 45 VTSA-F → 178 Accessories → 190 <p>→ www.festo.com/catalog/vtasa</p> <p>→ www.festo.com/catalog/vtasa-f</p>

Features and Benefits

Valve Manifolds Type 44 VTSA, Type 45 VTSA-F – Inch Series

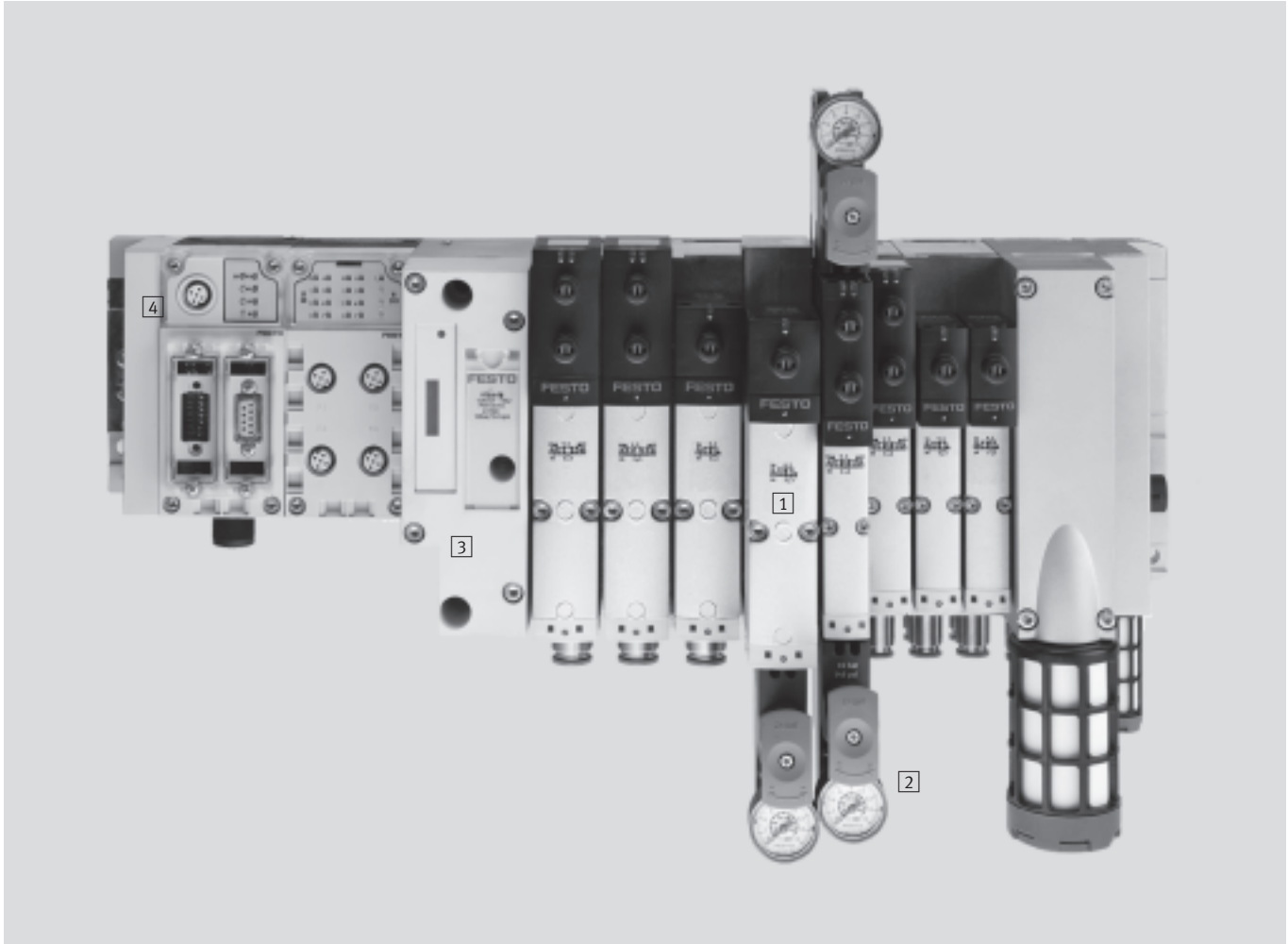

1 Combination of sizes

The flexible combination of different valve sizes on a single valve terminal (0.71 in, 1.02 in and 1.65 in) allows adaptation to different flow requirements. For greater freedom and optimized applications.

2 Operating efficiency

Adjustment of regulators without tools. And with the standardized operating direction from above for regulators and valves, this terminal offers the solution to just about every requirement in terms of functionality.

3 Connection to CPX

What about fieldbus and modular I/Os? Connection to the modern CPX terminal is an added benefit. This level of freedom, modularity, and versatility is unmatched in any valve manifold solution.

4 Decentralized intelligence

The CPX-MMI-1 hand-held device explains errors in plain text and helps expedite troubleshooting, reducing downtimes. Remote maintenance via Ethernet/Internet eliminates the need for servicing at night and over long distances, which can often be very expensive. The on-site intelligence permits CMS (Condition Monitoring Systems) for each valve and statistical error logging with history and timestamp.

A higher degree of modularity

- Valve manifold type 44 VTSA complies to ISO 15407-2 in width 0.71 and 1.02 in and with ISO 5599-2 in width 1.65 in. The VTSA terminal can be used for all applications
- Simple connection of pneumatic and electrical components
- Flow rate up to 53.0 scfm
- 5/2-way, 2x 3/2-way and 5/3-way valve functions
- Voltage options: 24 V DC or 110 V AC
- IP65 rated
- Modular and flexible
- Easy diagnostics and maintenance
- Reliable and durable
- Competitive pricing

Overview – Key Features

Valve Manifolds Type 44 VTSA, Type 45 VTSA-F – Inch Series

Valve Manifold

Reduced downtimes:
LED diagnosis on the spot

Width 0.71, 1.02 and 1.65 in
can be combined on a single
manifold without adapter

Pneumatic interface to CPX

Straightforward electrical
connections
– Fieldbus connection via CPX
– Multi-pin plug connection with
pre-assembled cable or manifold
strip (Cage Clamp)
– Control block via CPX
– Individual connection

CPX diagnostic interface for
handheld devices (channel-oriented
diagnosis down to the individual valve)

Quick mounting:
Direct mounting using screws or DIN H-rail

Secure:
Valves, outputs and logic voltage
can be switched off separately

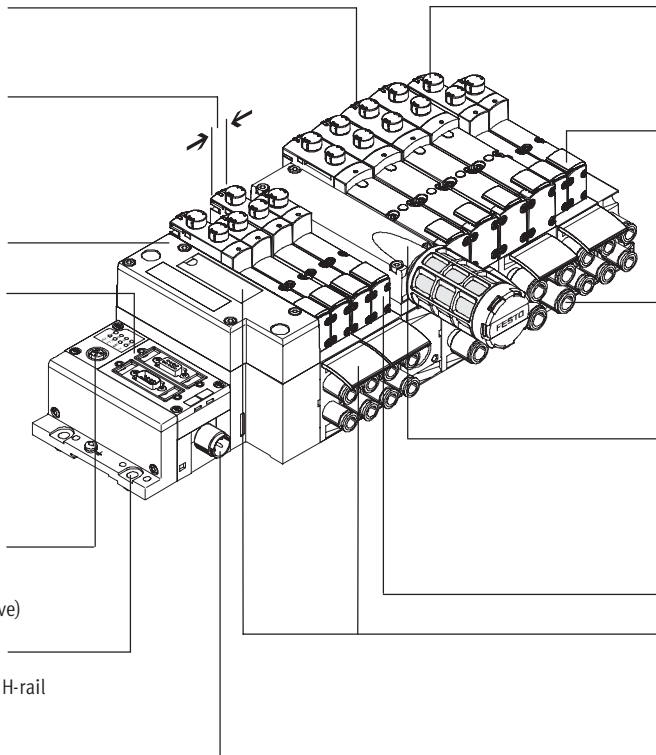

Reliable operation:
Manual override: pushing/detented
or with cover

Flexible:
– 32 valve positions/32 solenoid coils
– One valve series for a wide range of
flow rates

Functional:
Large ports, flow-optimized ducts,
robust metal thread or pre-assembled
QS connections

Modular:
Supply plates facilitate the creation of
multiple pressure zones as well as
numerous additional exhaust and supply
ports

Comprehensive valve functions

Practical:
Large inscription labels

Valve Functions

- 5/2-way valve
 - Single solenoid valve, pneumatic/spring return
 - Double solenoid valve
 - Double solenoid valve with dominant signal
- 2x 3/2-way valve, single solenoid
 - Normally open
 - Normally open, reversible
 - Normally closed
 - Normally closed, reversible
 - 1x normally open, 1x normally closed
 - 1x normally open, 1x normally closed, reversible
- 5/3-way valve
 - Mid-position pressurized
 - Mid-position closed
 - Mid-position exhausted

Special Features

Multi-pin plug manifold

- Max. 32 valve positions/
max. 32 solenoid coils
- Parallel modular valve linking
- Any compressed air supply
- Any number of pressure zones

Fieldbus manifold/control block

- Max. 32 valve positions/
max. 32 solenoid coils
- Any compressed air supply
- Any number of pressure zones

Individual valve

- Electrical connection via standardized
4-pin M12 plug or via 4-pin clamped
manifold connection for configuration
by the user
- Available with internal/external pilot
air supply

Combinable

- Width 0.71 in:
valve flow rate up to 24.7 scfm
- Width 1.02 in:
valve flow rate up to 49.4 scfm
- Width 1.65 in:
valve flow rate up to 53.0 scfm
- Width 1.65 in, 1.02 in and 0.71 in
can be combined on a single valve
manifold

Overview – Key Features

Valve Manifolds Type 44 VTSA, Type 45 VTSA-F – Inch Series

Individual Connection

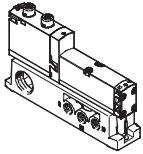
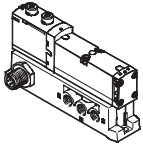

Valves on individual subbases can be used for actuators further away from the valve manifold.

The electrical connection is established using a standard 4-pin M12 plug 24 V DC (EN 61076-2-101)

or it can be configured by the user with a 4-pin clamped manifold connection 24 V DC or 110 V AC.

Manifold Connection

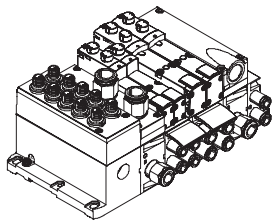

An individual connecting cable carries the control signal between the controller and the valve manifold.

The valve manifolds can be fitted with max. 20 valves and max. 20 solenoid coils.

The electrical connection is established via a 5-pin M12 plug 24 V DC

Multi-pin Plug Connection

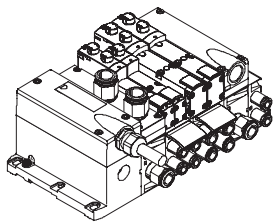

Control signals from the controller to the valve manifold are transmitted via a pre-assembled multi-core cable or a self-assembled multi-pin plug connection (CageClamp), which substantially reduces installation time.

The valve manifolds can be fitted with max. 32 valves and max. 32 solenoid coils.

Variants

- Multi-pin plug connection with manifold strip (CageClamp) 24 V DC or 110 V AC
- Pre-assembled connecting cable 24 V DC
- Sub-D plug connector for fitting by users, 37-pin

Overview – Key Features

Valve Manifolds Type 44 VTSA, Type 45 VTSA-F – Inch Series

Fieldbus Connection via the CPX System

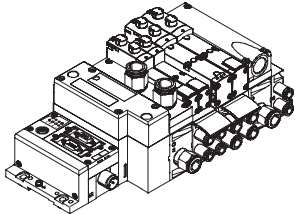

An integrated fieldbus node manages the communication connection to a higher-order PLC. This enables a space-saving pneumatic and electronic solution.

Valve manifolds with fieldbus interfaces can be configured with up to 16 manifold subbases. With 2 solenoid coils per connection, up to 32 solenoid coils can thus be actuated.

Variants

- Profibus-DP
- Interbus
- DeviceNet
- CANopen
- CC-Link
- Ethernet/IP
- CPX manifold

➔ www.festo.com/catalog/cpx

Control Block Connection via the CPX System

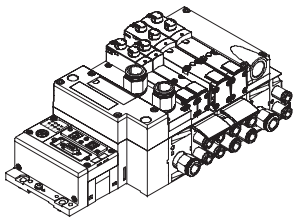

Controllers integrated in the Festo valve manifolds permit the construction of stand-alone control units to IP65, without control cabinets.

Using the slave operation mode, these valve manifolds can be used for intelligent pre-processing and are therefore ideal modules for designing decentralised intelligence.

In the master operation mode, manifold groups can be designed with many options and functions, which can autonomously control a medium-sized machine/system.

- CPX manifold

➔ www.festo.com/catalog/cpx

CP String Extension

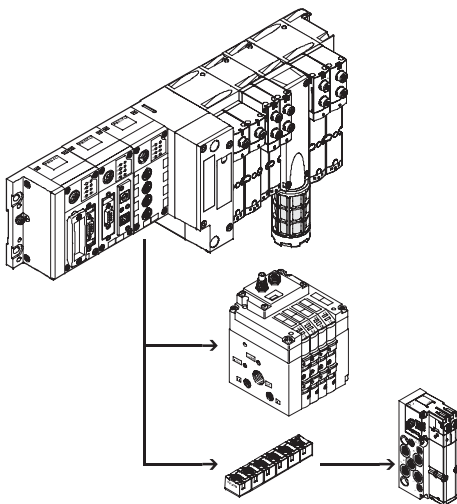

The optional string extension allows additional valve manifolds and I/O modules to be connected to the fieldbus node of the CPX manifold. Different input and output modules as well as CPV-SC, CPV and CPA valve manifolds can be connected. The maximum length of the CP string extension is 32.8 feet, which means that the extension modules can be mounted directly on site. All of the required electrical signals are transmitted via the CP cable, which in turn means that no further installation is needed on the extension module.

The CP string interface offers:

- 32 input signals
- 32 output signals for output modules 24 V DC or solenoid coils
- Logic and sensor supply for the input modules
- Load voltage supply for the valve manifolds
- Logic supply for the output modules

➔ www.festo.com/catalog/cpi

Overview – Pneumatic Components

Valve Manifolds Type 44 VTSA, Type 45 VTSA-F – Inch Series

Modular Pneumatic Components

The modular design of the VTSA/VTSA-F facilitates maximum flexibility right from the planning stage and offers maximum ease of service in operation.

The system consists of manifold subbases and valves. The manifold subbases are screwed together and thus form the support system for the valves.

Inside, the manifold subbases contain the connection ducts for supplying compressed air to and venting from the valve manifold as well as the working ports for the pneumatic cylinders from each valve.

Each manifold subbase is connected to the next using four screws. Individual manifold sections can be isolated and further blocks inserted by loosening these screws. This ensures that the valve manifold can be rapidly and reliably expanded.

Modularity in the basic system

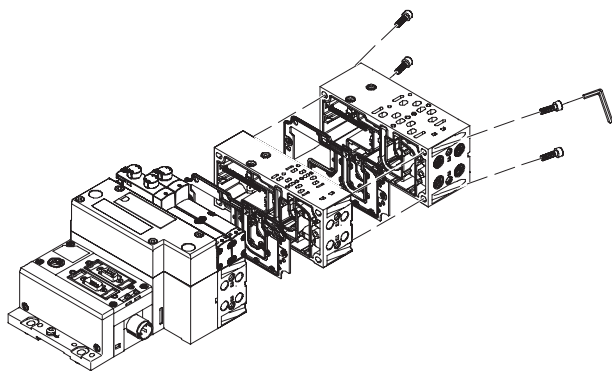

Modularity in the valves

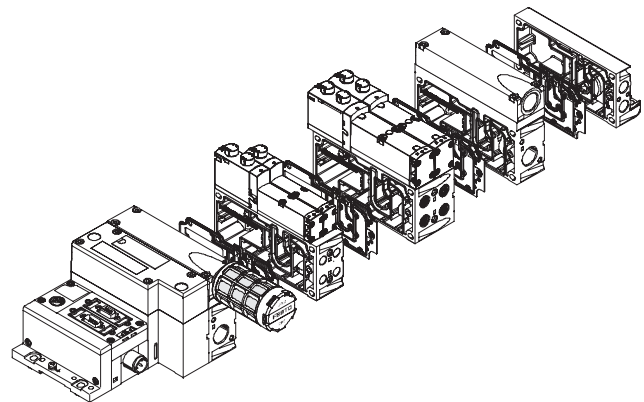

Modularity in the vertical stacking

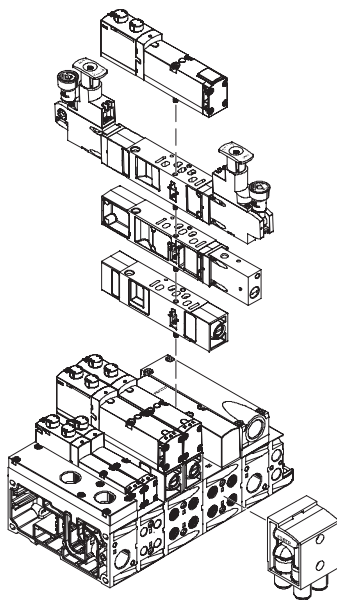

Overview – Electrical Components

Valve Manifolds Type 44 VTSA, Type 45 VTSA-F – Inch Series

Modular Electrical Peripherals

The manner in which the valves are actuated differs according to whether you are using a multi-pin manifold or fieldbus manifold.

The VTSA/-VTSA-F with CPX interface is based on the internal bus system of the CPX and uses this communication system for all solenoid coils and a range of electrical input and output functions.

Parallel linking facilitates the following:

- Transmission of switching information
- High valve density
- Compact design
- Position-based diagnosis
- Separate voltage supply for valves
- Flexible conversion without address shifting
- Transmission of status, parameter and diagnostic data

VTSA with electrical peripherals CPX

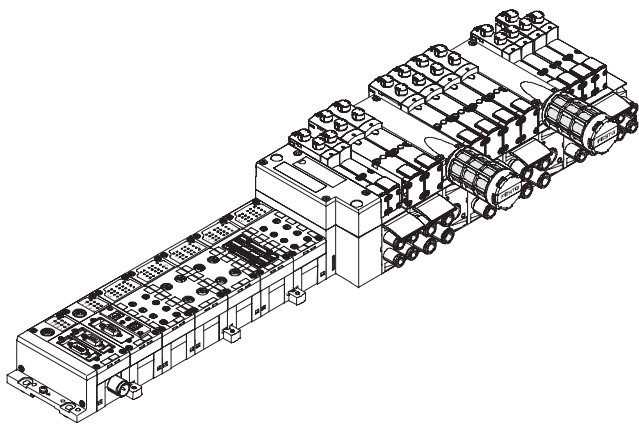

Modularity with electrical peripherals CPX

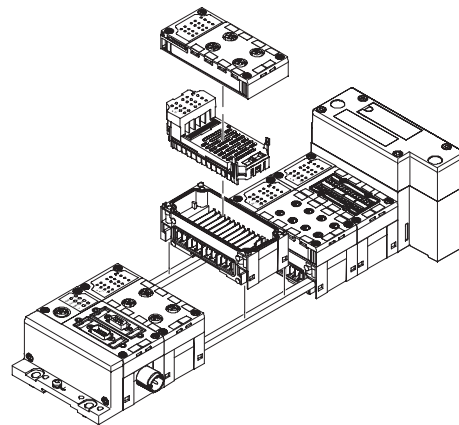

Overview – Multi-pin Connection

Valve Manifolds Type 44 VTSA, Type 45 VTSA-F – Inch Series

Valve Manifold with Multi-pin Plug Connection

Order code:

- 44E for the electrical components
 - 44P for the pneumatic components
 - 45P... for the pneumatic components.
- High flow rate with optimized manifold subbases.

Valve manifolds with multi-pin plug connection can be expanded with up to 32 valves with max. 32 solenoid coils.

The manifold subbases width 0.71 and 1.02 in are prepared for:

- 2 single solenoid valves
- 2 double solenoid valves

The manifold subbases width 1.65 in are prepared for:

- 1 single solenoid valve
- 1 double solenoid valve depending on the size.

- Double solenoid valve positions can be equipped with any valve or a blanking plate.
- Single solenoid valve positions can only be equipped with single solenoid valves or a blanking plate.

The following multi-pin plug connections to IP65 are available:

- 37-pin Sub-D connection (24 V DC):
The connecting cable can be ordered in lengths of 8.2, 16.4 and 32.8 ft for max. 8, 22 or 32 solenoid coils.
- Manifold strip (24 V DC or 110 V AC)

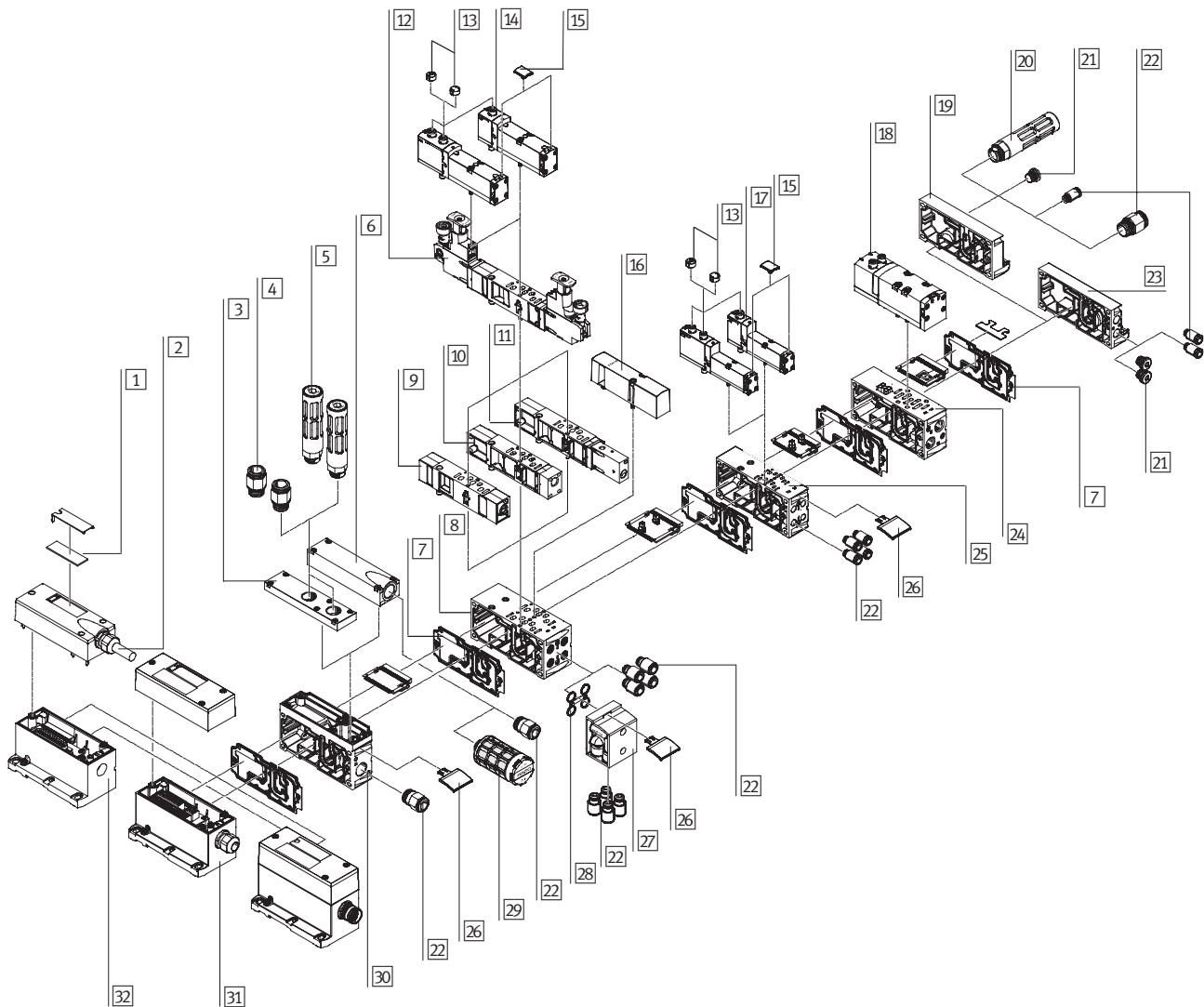

Overview – Multi-pin Connection

Valve Manifolds Type 44 VTSA, Type 45 VTSA-F – Inch Series

Valve Manifold with Multi-pin Plug Connection			
	Brief description	→ Page	
1	Inscription labels	Large, for multi-pin plug connection	–
2	Multi-core cable		98
3	Exhaust plate	Ports 3 and 5 separated	95
4	Fittings	For supply plate	99
5	Silencer	For supply plate	99
6	Exhaust port cover	For ducted exhaust air (ports 3 and 5 combined)	95
7	Duct separation/seal		95
8	Manifold subbase	For valves with a width of 1.02 in	95
9	Flow control plate		97
10	Vertical supply plate		95
11	Vertical shut-off plate		97
12	Pressure regulator plate		96
13	Cover cap	For manual override, pushing, covered	99
14	Valve	Width 1.02 in	91
15	Inscription label holder	For valve	99
16	Blanking plate	For unused valve position (vacant position)	99
17	Valve	Width 0.71 in	91
18	Valve	Width 1.65 in (type 44 only)	91
19	Right-hand end plate		93
20	Silencer	For end plate	99
21	Blanking plugs		100
22	Fittings		99
23	End plate with pilot air selector		93
24	Manifold subbase	For valves with a width of 1.65 in (type 44 only)	93
25	Manifold subbase	For valves with a width of 0.71 in	93
26	Inscription label holder	For supply plate, subbase, 90° connection plate	99
27	90° connection plate		95
28	Seals		95
29	Silencer		99
30	Supply plate		95
31	Multi-pin plug connection	Via manifold strip (CageClamp) 24 V DC or 110 V AC	97
32	Multi-pin plug connection	With multi-core cable 24 V DC	97

Note

The choice of silencer to be used depends on the type of vertical stacking of the valve positions to the left and the right of the supply plate.

Exhaust port cover [6](#) with plastic exhaust air silencer type U-1/2
– A pressure regulator plate

Exhaust port cover [6](#) with metal exhaust air silencer type U-1/2-B
– P pressure regulator plate
– B pressure regulator plate
– AB pressure regulator plate
– Vertical shut-off plate
– Vertical supply plate
– Flow control plate

Overview – Fieldbus Connection

Valve Manifolds Type 44 VTSA, Type 45 VTSA-F – Inch Series

Valve Manifold with Fieldbus Connection, Control Block (Electrical Peripherals CPX)

Order code:

- 50E... for the electrical peripherals
- 44P for the pneumatic components
- 45P... for the pneumatic components.
High flow rate with optimized manifold subbases.

Valve manifolds with fieldbus interface can be expanded with up to 32 valves with max. 32 solenoid coils. Each valve position can be fitted with any valve or a blanking plate.

The rules for CPX apply to the equipment that can be used in combination with the electrical peripherals CPX.

In general:

- Max. 10 electrical modules
- Digital inputs/outputs
- Analogue inputs/outputs
- Parameterisation of inputs and outputs
- Integrated feature-rich diagnostic system
- Preventive maintenance concepts

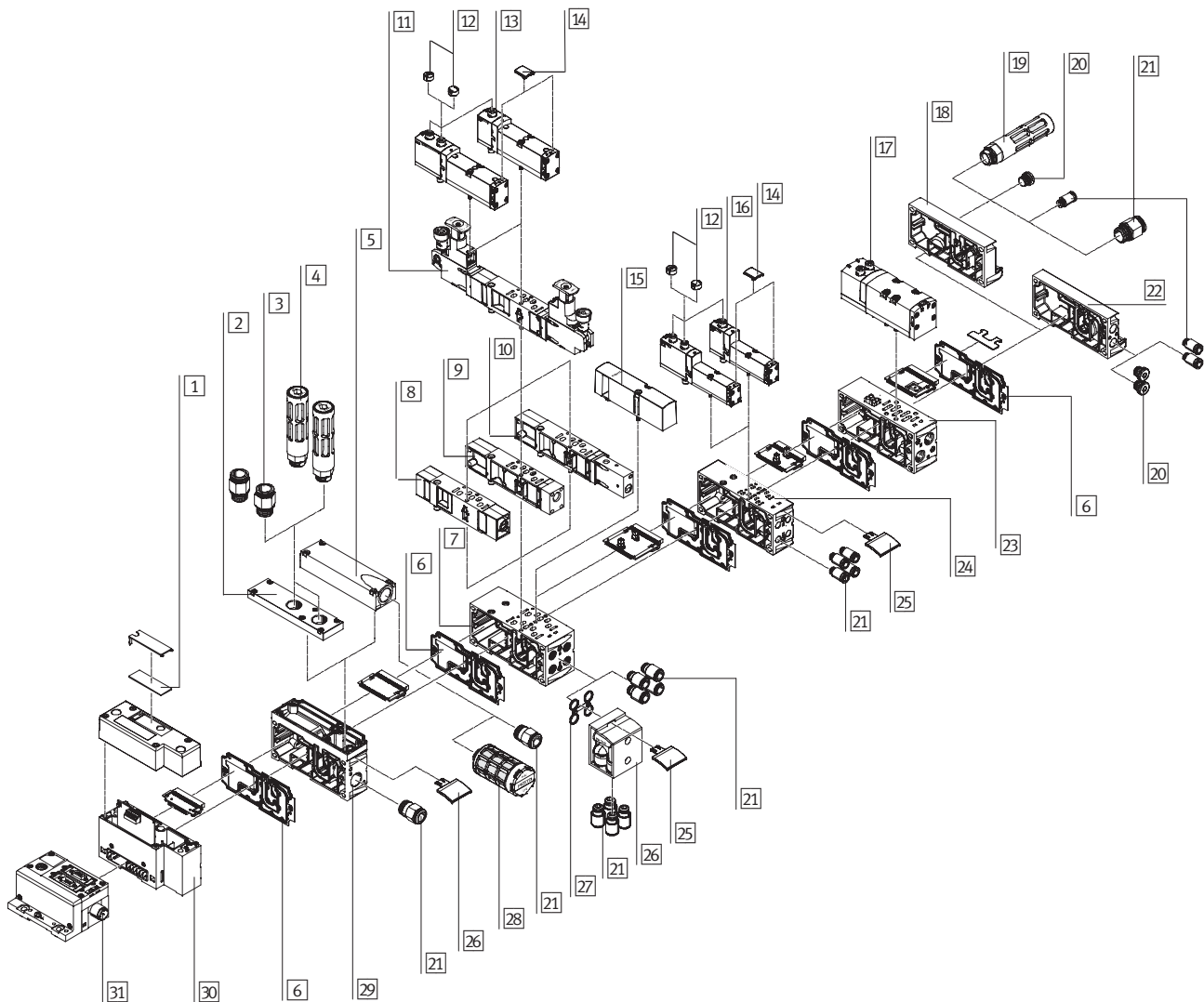

Overview – Fieldbus Connection

Valve Manifolds Type 44 VTSA, Type 45 VTSA-F – Inch Series

Valve Manifold with Fieldbus Connection, Control Block (Electrical Peripherals CPX)			
	Brief description	→ Page	
1	Inscription labels	Large, for pneumatic interface CPX	–
2	Exhaust plate	Ports 3 and 5 separated	95
3	Fittings	For supply plate	99
4	Silencer	For supply plate	99
5	Exhaust port cover	For ducted exhaust air (ports 3 and 5 combined)	95
6	Duct separation/seal		95
7	Manifold subbase	For valves with a width of 1.02 in	93
8	Flow control plate		97
9	Vertical supply plate		95
10	Vertical shut-off plate		97
11	Pressure regulator plate		96
12	Cover cap	For manual override, pushing, covered	99
13	Valve	Width 1.02 in	91
14	Inscription label holder	For valve	99
15	Blanking plate	For unused valve position (vacant position)	99
16	Valve	Width 0.71 in	91
17	Valve	Width 1.65 in (type 44 only)	91
18	Right-hand end plate		93
19	Silencer	For end plate	99
20	Blanking plugs		100
21	Fittings		99
22	End plate with pilot air selector		93
23	Manifold subbase	For valves with a width of 1.65 in (type 44 only)	93
24	Manifold subbase	For valves with a width of 0.71 in	93
25	Inscription label holder	For supply plate/subbase/90° connection plate	99
26	90° connection plate		95
27	Seals		95
28	Silencer		99
29	Supply plate		95
30	Pneumatic interface		97
31	Fieldbus interface		–

Note

The choice of silencer to be used depends on the type of vertical stacking of the valve positions to the left and the right of the supply plate.

Exhaust port cover [5] with plastic exhaust air silencer type U-1/2
– A pressure regulator plate

Exhaust port cover [5] with metal exhaust air silencer type U-1/2-B
– P pressure regulator plate
– B pressure regulator plate
– AB pressure regulator plate
– Vertical shut-off plate
– Vertical supply plate
– Flow control plate

Overview – Single Subbases

Valve Manifolds Type 44 VTSA, Type 45 VTSA-F – Inch Series

Individual Subbase

Order code:

- Using individual part numbers

Individual subbases can be equipped with any valve.

The electrical connection is established using a standard 4-pin M12 plug (EN 61076-2-101) or it can be

configured by the user with a 4-pin clamped manifold connection/open cable end.

Width 0.71 in with M12 plug

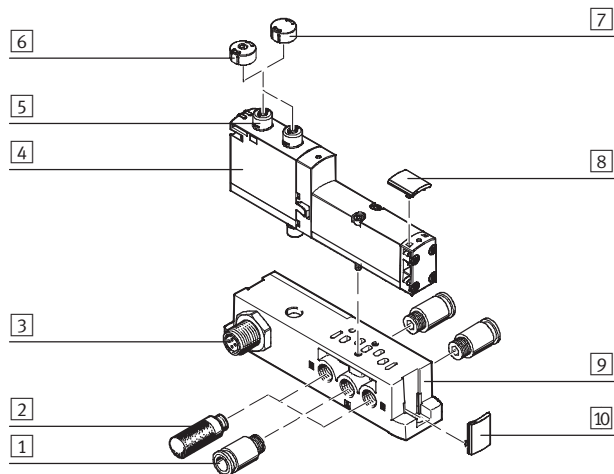

Width 1.02 in with M12 plug

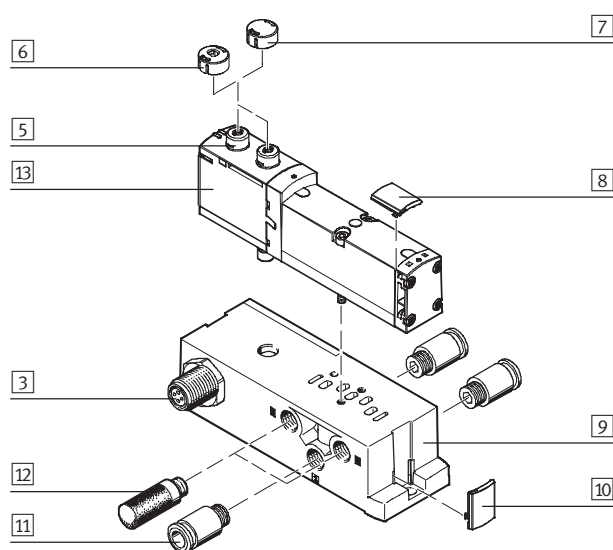

	Brief description	→ Page	
1	Fitting	1/8 NPT for supply/exhaust ports (1, 3, 5) and working ports (2, 4)	99
2	Silencer	1/8 NPT for supply/exhaust ports (1, 3, 5)	99
3	Electrical connection M12 ¹⁾	4-pin	–
4	VSVA valve	Width 0.71 in	91
5	Manual override	Non-detenting/detenting, per solenoid coil	–
6	Cover cap	For manual override, pushing	99
7	Cover cap	For manual override, covered	99
8	Inscription label holder	For valves	99
9	Individual subbase	For valve VSVA	94
10	Inscription label holder	For manifold blocks	99
11	Fitting	1/4 NPT for supply/exhaust ports (1, 3, 5) and working ports (2, 4)	99
12	Silencer	1/4 NPT for supply/exhaust ports (1, 3, 5)	99
13	VSVA valve	Width 1.02 in	91

1) Only with 24 VDC

Overview – Single Subbases

Valve Manifolds Type 44 VTSA, Type 45 VTSA-F – Inch Series

Individual Subbase

Width 0.71 in with clamped manifold connection

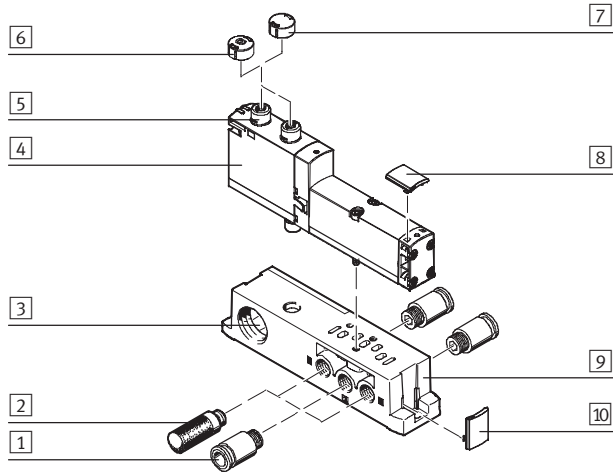

Width 1.02 in with clamped manifold connection

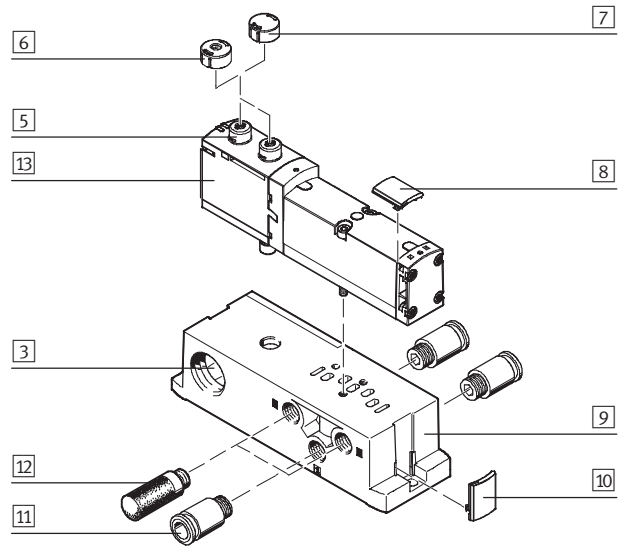

	Brief description	→ Page	
1	Fitting	1/8 NPT for supply/exhaust ports (1, 3, 5) and working ports (2, 4)	99
2	Silencer	1/8 NPT for supply/exhaust ports (1, 3, 5)	99
3	Manifold connection ¹⁾	4-pin, configured by the user	-
4	VSVA valve	Width 0.71 in	91
5	Manual override	By pushing/detenting, per solenoid coil	-
6	Cover cap	For manual override, pushing	99
7	Cover cap	For manual override, covered	99
8	Inscription label holder	For valves	99
9	Individual subbase	For valve VSVA	94
10	Inscription label holder	For manifold blocks	99
11	Fitting	1/4 NPT for supply/exhaust ports (1, 3, 5) and working ports (2, 4)	99
12	Silencer	1/4 NPT for supply/exhaust ports (1, 3, 5)	99
13	VSVA valve	Width 1.02 in	91

1) 24 VDC or 110 VAC

Overview – Single Subbases

Valve Manifolds Type 44 VTSA – Inch Series

Individual Subbase

Width 1.65 in with spring-loaded manifold/open end

Width 1.65 in with M12 plug

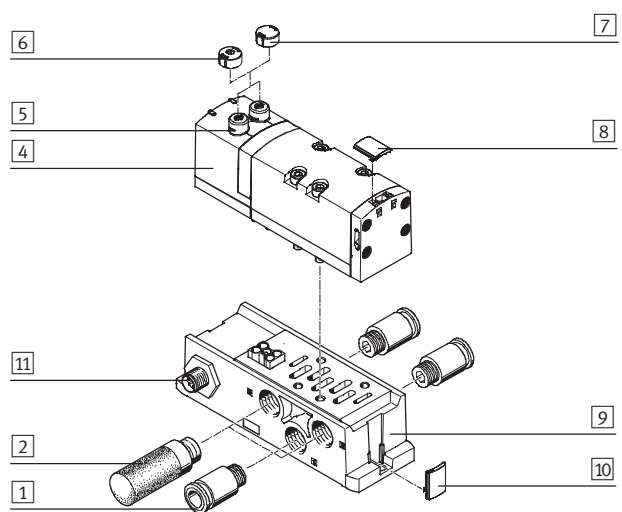
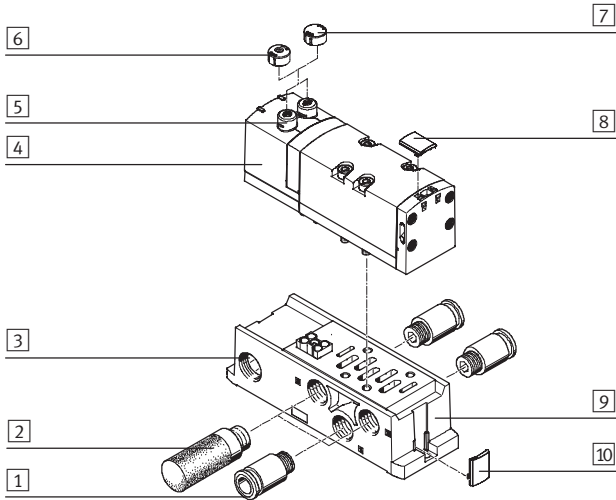

	Brief description	→ Page	
1	Fitting	3/8 NPT for supply/exhaust ports (1, 3, 5) and working ports (2, 4)	99
2	Silencer	3/8 NPT for supply/exhaust ports (1, 3, 5)	99
3	Clamped manifold connection/open end ¹⁾	4-pin, configured by the user	–
4	VSVA valve	Width 1.65 in	91
5	Manual override	Pushing/detenting, per solenoid coil	–
6	Cover cap	For manual override, pushing	99
7	Cover cap	For manual override, covered	99
8	Inscription label holder	For valves	99
9	Individual subbase	For valve VSVA	94
10	Inscription label holder	For manifold blocks	99
11	Electrical connection M12 ²⁾	4-pin	–

1) 24 V DC or 110 V AC

2) Only for 24 V DC

Overview – Individual Connection

Valve Manifolds Type 44 VTSA, Type 45 VTSA-F – Inch Series

Valve Manifold with Individual Connection

Order code:

- 44E for the electrical components
- 45E for the electrical components
- 44P for the pneumatic components
- 45P for the pneumatic components

Valve manifolds with individual connection can be expanded with up to 20 valves with max. 20 solenoid coils.

The manifold subbases width 0.71 and 1.02 in are either prepared for:

- 2 single solenoid valves
- 2 double solenoid valves

The manifold subbases width 1.65 in are prepared for:

- 1 single solenoid valve
- 1 double solenoid valve depending on the size.

- Double solenoid valve positions can be fitted with any valve or a blanking plate.
- Single solenoid valve positions can only be fitted with single solenoid valves or a blanking plate.

The electrical connection is established via a 5-pin M12 plug.

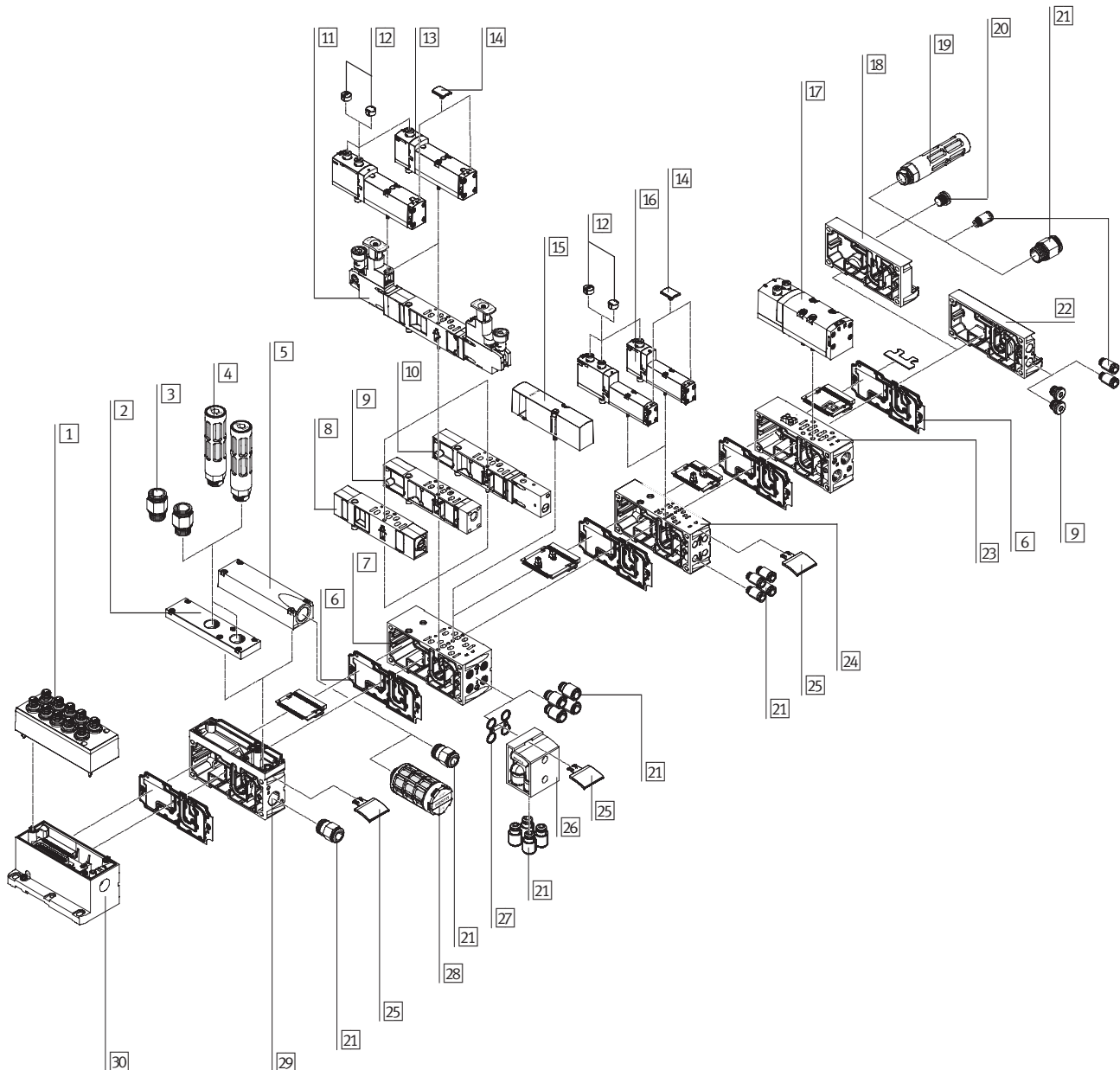

Overview – Individual Connection

Valve Manifolds Type 44 VTSA, Type 45 VTSA-F – Inch Series

Valve Manifold with Individual Connection			
	Brief description	→ Page	
1	Cover	For individual connection	97
2	Exhaust plate	Ports 3 and 5 separated	95
3	Fittings	For supply plate	99
4	Silencer	For supply plate	99
5	Exhaust port cover	For ducted exhaust air (ports 3 and 5 combined)	95
6	Duct separation/seal		95
7	Manifold subbase	For valves with a width of 1.02 in	93
8	Flow control plate		97
9	Vertical supply plate		95
10	Vertical shut-off plate		97
11	Pressure regulator plate		96
12	Cover cap	For manual override, pushing, covered	99
13	Valve	Width 1.02 in	91
14	Inscription label holder	For valve	99
15	Blanking plate	For unused valve position (vacant position)	99
16	Valve	Width 0.71 in	91
17	Valve	Width 1.65 in (type 44 only)	93
18	Right-hand end plate		93
19	Silencer	For end plate	99
20	Blanking plugs		100
21	Fittings		99
22	End plate with pilot air selector		93
23	Manifold subbase	For valves with a width of 1.65 in (type 44 only)	93
24	Manifold subbase	For valves with a width of 0.71 in	93
25	Inscription label holder	For supply plate, subbase, 90° connection plate	99
26	90° connection plate		95
27	Seals		95
28	Silencer		99
29	Supply plate		95
30	Multi-pin plug connection	Individual connection with M12, 10-way or 6-way (including cover)	97

Note

The choice of silencer to be used depends on the type of vertical stacking of the valve positions to the left and the right of the supply plate.

Exhaust port cover [5] with plastic exhaust air silencer type U-1/2
 – A pressure regulator plate

Exhaust port cover [5] with metal exhaust air silencer type U-1/2-B
 – P pressure regulator plate
 – B pressure regulator plate
 – AB pressure regulator plate
 – Vertical shut-off plate
 – Vertical supply plate
 – Flow control plate

Pneumatic Components

Valve Manifolds Type 44 VTSA, Type 45 VTSA-F – Inch Series

Subbase Valve

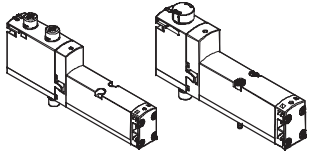

VTSA/VTSA-F offers a comprehensive range of valve functions. All valves are equipped with piston spool and patented sealing system which facilitate efficient sealing, a broad pressure range and long service life.

Subbase valves can be quickly replaced since the tubing connections remain on the subbase. Irrespective of the valve function there are subbase valves with one solenoid coil (single solenoid) or with two solenoid coils for double solenoid or double valve functions.

Reverse operation

Select reverse operation (code Z) if you wish to operate an actuator (cylinder) with different pressures for the forward and return stroke. It must be noted here that these valves must be operated via a separate pressure zone.

Blanking Plate

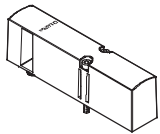

Plate without valve function for reserving valve positions on a valve manifold.

Valves and blanking plates are attached to the manifold subbase using two screws.

Valve Function					
Code	Circuit symbol	Width			Description
		0.71 in	1.02 in	1.65 in	
M		■	■	■	5/2-way valve, single solenoid • Pneumatic spring return
O		■	■	■	5/2-way valve, single solenoid • Spring return
J		■	■	■	5/2-way valve, double solenoid
D		■	■	■	5/2-way valve, double solenoid • Dominant signal with port 14 on the control side
N		■	■	■	2x 3/2-way valve, single solenoid • Normally open • Pneumatic spring return
K		■	■	■	2x 3/2-way valve, single solenoid • Normally closed • Pneumatic spring return

Pneumatic Components

Valve Manifolds Type 44 VTSA, Type 45 VTSA-F – Inch Series



Valve Function					
Code	Circuit symbol	Width			Description
		0.71 in	1.02 in	1.65 in	
H		■	■	■	2x 3/2-way valve, single solenoid <ul style="list-style-type: none"> • Normal position <ul style="list-style-type: none"> – 1x closed – 1x open • Pneumatic spring return • Operating pressure > 44 psi
B		■	■	■	5/3-way valve <ul style="list-style-type: none"> • Mid-position pressurized¹⁾ • Spring force return
G		■	■	■	5/3-way valve <ul style="list-style-type: none"> • Mid-position closed¹⁾ • Spring force return
E		■	■	■	5/3-way valve <ul style="list-style-type: none"> • Mid-position exhausted¹⁾ • Spring force return
P		■	■	■	2x 3/2-way valve, single solenoid <ul style="list-style-type: none"> • Reverse operation • Normally open • Pneumatic spring return
Q		■	■	■	2x 3/2-way valve, single solenoid <ul style="list-style-type: none"> • Reverse operation • Normally closed • Pneumatic spring return
R		■	■	■	2x 3/2-way valve, single solenoid <ul style="list-style-type: none"> • Reverse operation • Normal position <ul style="list-style-type: none"> – 1x closed – 1x open • Pneumatic spring return
L		■	■	■	For valve manifold only: Blanking plate for vacant valve position

1) If neither solenoid coil is energized, the valve moves to its mid-position by means of spring force.
 If both coils are energized at the same time, the valve remains in the previously assumed switching position.

Design	
Valve replacement The valves are attached to the metal manifold subbase using two screws. This means that they can be easily replaced. The high-quality of the manifold subbase guarantees good long-term sealing tightness.	Expansion Vacant positions can be equipped with valves at a later date. The dimensions, mounting points and existing pneumatic installations remain unchanged during this process. The order code VSVA-... is located on the front of the valve beneath the manual override.

Pneumatic Components

Valve Manifolds Type 44 VTSA, Type 45 VTSA-F – Inch Series

Vertical Stacking

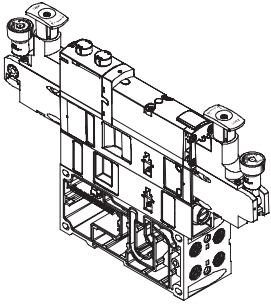

Additional function units can be added to each valve position between the subbase and the valve. These functions, designated as vertical stacking, facilitate special functioning or control

of the respective individual valve position. Combinations of several valve sizes on one valve manifold are possible.

Note

The operation of the components should be checked when combining multiple vertical stacking components.

The following combination of reversible valve manifolds with vertical stacking components is not permitted:

- Reversible pressure regulating plates
- Throttle plates
- Vertical isolating plates
- Vertical supply plates

Vertical stacking components

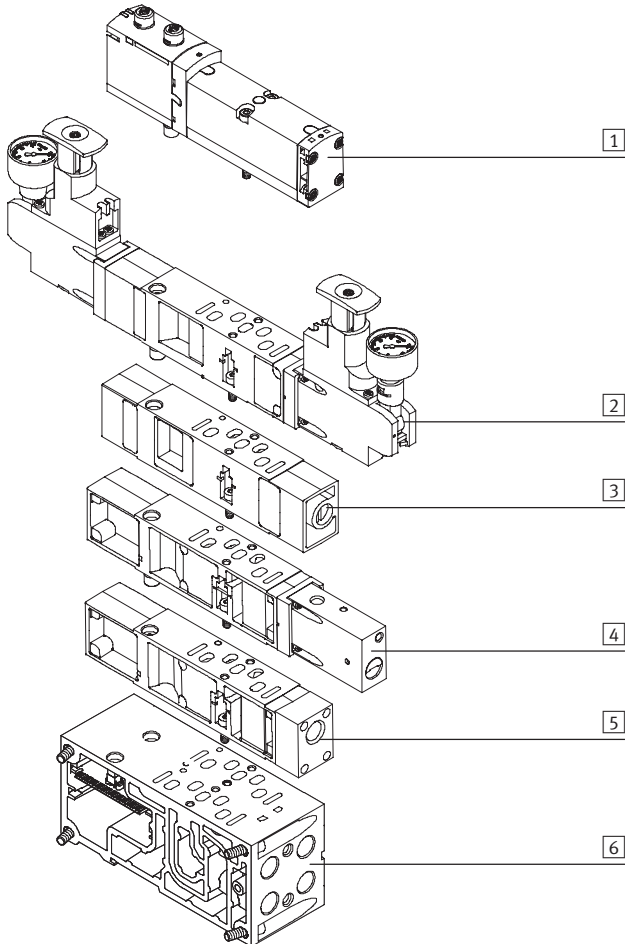

The following component sequence is recommended for valve positions with vertical stacking:

- 1 ISO valve
- 2 Pressure regulator plate
- 3 Flow control plate
- 4 Vertical shut-off plate
- 5 Vertical supply plate
- 6 Manifold subbase

Pneumatic Components

Valve Manifolds Type 44 VTSA, Type 45 VTSA-F – Inch Series



Vertical Stacking

Pressure regulator plate

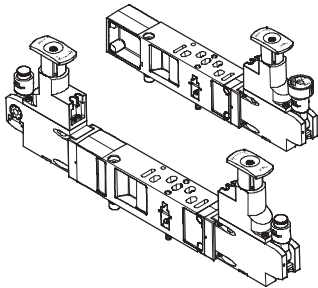

An adjustable pressure regulator can be installed between the subbase and the valve in order to control the force of the respective actuator.

This pressure regulating valve maintains an essentially constant output pressure (secondary side) independent of pressure fluctuations (primary side) and air consumption.

Standard version:

- Standard port pattern to ISO 15407-2 or ISO 5599-2 (type 44 only)
- For supply pressure up to 88 psi or up to 147 psi
- Without pressure gauge (optional)
- Regulator knob with 3 positions (locked, reference position, free running)

Mode of operation of the pressure regulating plate (P regulation) for port 1; code: ZA, ZF

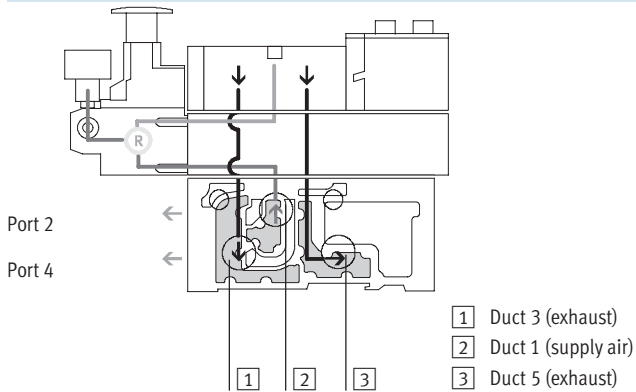

This pressure regulator regulates the pressure before the valve in duct 1. Ducts 2 and 4 thus have the same regulated pressure.

During venting, the exhaust flow in the valve is from duct 2 to duct 3 and from duct 4 to duct 5.

Advantages

- The pressure regulator is not affected by venting, as the pressure is regulated before the valve.
- The pressure regulator can always be adjusted, as the pressure from the valve manifold is always present.

Application examples

- An equal working pressure is required at working ports 2 and 4
- A lower working pressure (e.g. 44 psi) than the operating pressure present on the valve manifold (e.g. 118 psi) is required.

Mode of operation of the pressure regulating plate (A/B regulation) for ports 2 and 4; code: ZD, ZI

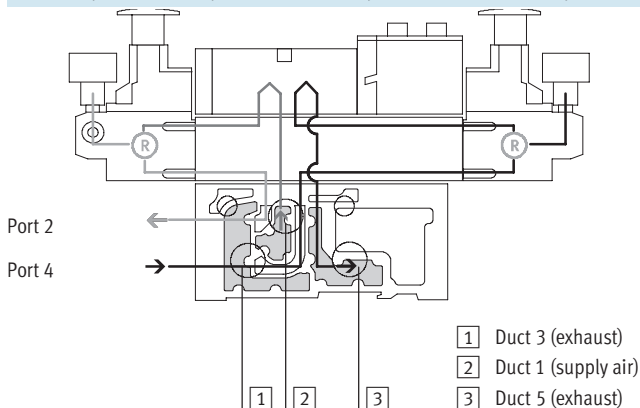

This pressure regulator regulates the pressure in ducts 2 and 4 after the pressure medium flows through the valve. During venting, the exhaust flow in the valve is from duct 2 to duct 3 and from duct 4 to duct 5 via the pressure regulator.

Example with the following switching position:
The supply air flows from duct 1 of the manifold subbase through the valve to duct 2, it is then regulated and made available at port 2 of the manifold subbase. At the same time, venting takes place via duct 4 of the manifold subbase, via the regulator and via the valve into duct 5 of the manifold subbase.

Restrictions

- The pressure regulator cannot be adjusted in the exhaust position. For example, the pressure regulator for duct 4 cannot be adjusted when the valve is pressurized in the switching position from duct 1 to duct 2 and exhausted from duct 4 to duct 5.

Application examples

- When two different working pressures are required instead of the valve manifold operating pressure at ports 2 and 4.

Pneumatic Components

Valve Manifolds Type 44 VTSA, Type 45 VTSA-F – Inch Series

Vertical Stacking

Mode of operation of the pressure regulating plate (A/B regulation, reversible) for ports 2 and 4, reversible; code: ZE, ZI

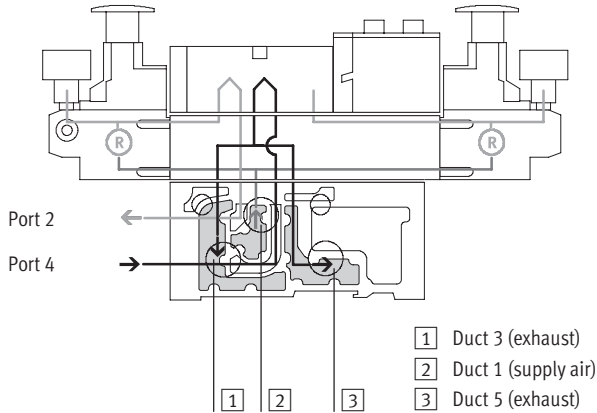

With this pressure regulator, the supply air (duct 1) is split and routed directly to both pressure regulators. The regulated compressed air is present in ducts 3 and 5 on the valve. The valve is thus operated in reversible mode. This means

- Duct 3 routes the working pressure to port 2
- Duct 5 routes the working pressure to port 4

Example with the following switching position:

The supply air in duct 1 is split among ducts 3 and 5 in the regulator and flows from here to the valve. In the valve, the supply air is routed to port 2 of the manifold subbase. The exhaust air is simultaneously routed via duct 4 of the manifold subbase and via the valve to regulator duct 1, where it is split between ducts 3 and 5 and then drawn off via the manifold subbase.

Application examples

- When two different pressures are required in ducts 2 and 4 instead of the operating pressure.
- When fast exhaust performance is required.
- When the pressure regulator must always be adjustable.

Note

- Reversible pressure regulating plates may only be combined with valves that can be operated in reversible mode.
- Valves in valve positions with vertical shut-off plates are operated with internal pilot air supply, even when the valve manifold is operated with external pilot air supply.
- The following combination of reversible valve manifolds with vertical stacking components is not permitted:
 - Reversible pressure regulating plates
 - Flow control plates
 - Vertical shut-off plates
 - Vertical supply plates

Advantages

- Fast cycle times.
- 50% higher exhaust flow rate, as air is not exhausted via the pressure regulator. The load on the pressure regulator is also reduced.
- No quick exhaust valves are required.
- Operating pressure is always present at the pressure regulator, as the pressure is regulated before the valve, i.e. the regulator can always be adjusted.

Disadvantages

- 2x 3/2-way valves (code N, K, H) not used, as pressure is present at ports 3 and 5.
- No practical combination with a flow control plate possible.

Pneumatic Components

Valve Manifolds Type 44 VTSA, Type 45 VTSA-F – Inch Series

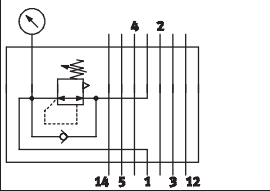
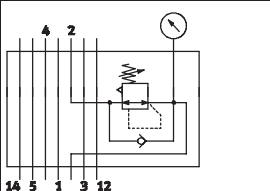
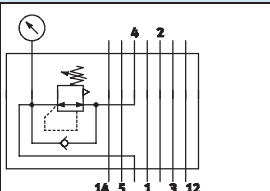
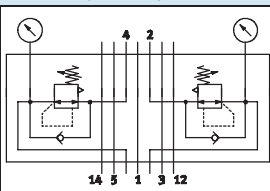
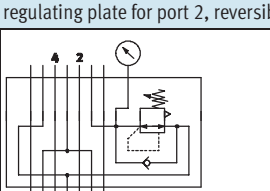
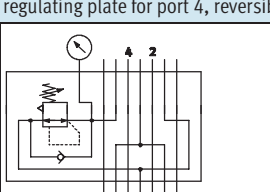

Vertical Stacking – Pressure Regulating Plate								
Code	Type	Width			Supply pressure		Description	
		0.71 in	1.02 in	1.65 in	88 psi	147 psi		
Pressure regulating plate for port 1 (P regulator)								
ZA		VABF-S4-...-R1C2-C-10	■	■	■	-	■	<ul style="list-style-type: none"> Regulates the operating pressure in duct 1 before the directional control valve
ZF		VABF-S4-...-R1C2-C-6	■	■	■	■	-	
Pressure regulating plate for port 2 (B regulator)								
ZC		VABF-S4-...-R2C2-C-10	■	■	■	-	■	<ul style="list-style-type: none"> Regulates the operating pressure in duct 2 after the directional control valve
ZH		VABF-S4-...-R2C2-C-6	■	■	■	■	-	
Pressure regulating plate for port 4 (A regulator)								
ZB		VABF-S4-...-R3C2-C-10	■	■	■	-	■	<ul style="list-style-type: none"> Regulates the operating pressure in duct 4 after the directional control valve
ZG		VABF-S4-...-R3C2-C-6	■	■	■	■	-	
Pressure regulating plate for ports 2 and 4 (AB regulator)								
ZD		VABF-S4-...-R4C2-C-10	■	■	■	-	■	<ul style="list-style-type: none"> Regulates the operating pressure in ducts 2 and 4 after the directional control valve
ZI		VABF-S4-...-R4C2-C-6	■	■	■	■	-	
Pressure regulating plate for port 2, reversible (B regulator)								
ZL		VABF-S4-...-R6C2-C-10	■	■	■	-	■	<ul style="list-style-type: none"> Reversible pressure regulator for port 2
ZN		VABF-S4-...-R6C2-C-6	■	■	■	■	-	
Pressure regulating plate for port 4, reversible (A regulator)								
ZK		VABF-S4-...-R7C2-C-10	■	■	■	-	■	<ul style="list-style-type: none"> Reversible pressure regulator for port 4
ZM		VABF-S4-...-R7C2-C-6	■	■	■	■	-	

Pneumatic Components

Valve Manifolds Type 44 VTSA, Type 45 VTSA-F – Inch Series



Vertical Stacking – Pressure Regulating Plate								
Code		Type	Width			Supply pressure		Description
			0.71 in	1.02 in	1.65 in	88 psi	147 psi	
Pressure regulating plate for ports 2 and 4, reversible (AB regulator)								
ZE		VABF-S4-...-R5C2-C-10	■	■	■	-	■	<ul style="list-style-type: none"> • Reversible pressure regulator for ports 2 and 4 • Pressure regulation before the valve • Redirects the operating pressure from duct 1 to ducts 3 and 5 • Routes the exhaust air from duct 1 to ducts 3 and 5
ZJ		VABF-S4-...-R5C2-C-6	■	■	■	■	-	<p>Note</p> <p>This pressure regulating plate cannot be combined with standard 2x 3/2-way valves (code N, K, H). Reversible 2x 3/2-way valves (code P, Q, R) must not be operated in a separate pressure zone in combination with these pressure regulators.</p>

Pneumatic Components

Valve Manifolds Type 44 VTSA, Type 45 VTSA-F – Inch Series



Vertical Stacking – Flow Control Plate

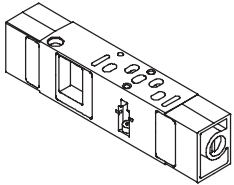

This plate is used for exhaust air flow control in ducts 3 and 5 of a valve in order to adjust the speed of the actuator.

Ducts 3 and 5 can be adjusted independently of each other.

Note

On reversible valve manifolds, supply air flow control takes place in ducts 3 and 5 before the valve.

Code	Type	Width			Description
		0.71 in	1.02 in	1.65 in	
X	VABF-S4-...F1B1-C	■	■	■	<ul style="list-style-type: none"> Controls the flow of exhaust air after the valve to ducts 3 and 5

Vertical Stacking – Vertical Shut-off Plate

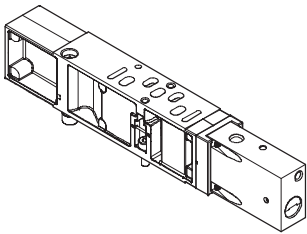

With this plate a valve can be shut off from the supply pressure of the Manifold. This means that the valve can be removed without shutting off the pressure.

Following activation of the shut-off, the exhaust air/return air from the cylinder is drawn off via the M5 threaded connection.

Note

It must be ensured that the operating pressure of the valve manifold lies within the range of the required pilot pressure (i.e. min. 44 psi).

Code	Type	Width			Description
		0.71 in	1.02 in	1.65 in	
ZT	VABF-S4-...L1D1-C	■	■	■	<ul style="list-style-type: none"> 2/2-way valve for shutting off the operating pressure at the valve position Blocks ducts 12 and 14 for the valve position Supplies the valve position with internal pilot air

Vertical Stacking – Vertical Supply Plate

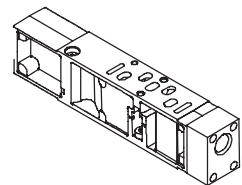

With this plate a valve can be supplied with individual operating pressure independently of the operating pressure of the manifold.

Code	Type	Width			Description
		0.71 in	1.02 in	1.65 in	
ZU	VABF-S4-...P1A3-...	■	■	■	<ul style="list-style-type: none"> Plate with port 11 for supplying an individual operating pressure for a valve position

Pneumatic Components

Valve Manifolds Type 44 VTSA, Type 45 VTSA-F – Inch Series

Manifold Subbase

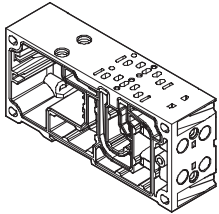

VTSA/VTSA-F is based on a modular system which consists of manifold subbases and valves. Manifold subbases are available for valve width 0.71 and 1.02 in in a double grid, i.e. two valves per manifold subbase. For width 1.65 in (type 44 only) there are manifold subbases for one valve per subbase .

The manifold subbase contains a ducting seal and electrical linking. They can be freely mixed within a valve manifold. The manifold subbases are screwed together and thus form the support system for the valves. Inside the manifold blocks are the connection channels for supplying compressed air to and venting from the valves on the manifold as well as the

working lines for the pneumatic cylinders for each valve. Each manifold subbase is connected to the next using four screws. Individual manifold sections can be isolated and further manifold subbases inserted by loosening these screws. This ensures that the valve manifold can be rapidly and reliably expanded.

Port Patterns on the Manifold Subbase

Type 44 VTSA

Width 0.71 in

Width 1.02 in

Width 1.65 in

Type 45 VTSA-F

Width 0.71 in

Width 1.02 in

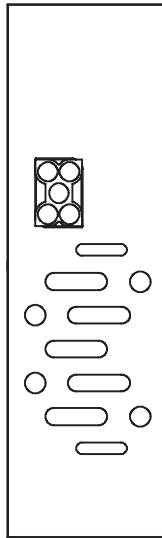
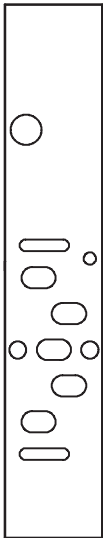

90° Connection Plate for Working Ports (2, 4) of the Manifold Subbases

Code	Image	Type	Width			Ports	Working ports (2, 4) in the 90° connection plate
			0.71 in	1.02 in	1.65 in		
P		NPT thread: VABF-S4-...-A2G2-N...	■	■	■	2 and 4	Outlet at bottom <ul style="list-style-type: none"> • Connection size for 0.71 in width: 1/8 NPT • Connection size for 1.02 in width: 1/4 NPT • Connection size for 1.65 in width: 3/8 NPT

Pneumatic Components

Valve Manifolds Type 44 VTSA, Type 45 VTSA-F – Inch Series



Manifold Subbase Variants – Type 44 VTSA							
Code	Image	Type	Width			No. of valve positions/solenoid coils	Working ports (2, 4) on manifold subbase
			0.71 in	1.02 in	1.65 in		
Manifold subbase for multi-pin plug/fieldbus connection for double solenoid valves							
A AK		NPT thread: VABV-S4-2S-N18-2T2	■	-	-	2/4	• Connection sizes for 0.71 in width: 1/8 NPT, QS-1/8-5/16-U, QS-1/8-1/4-U
B BK		NPT thread: VABV-S4-1S-N14-2T2	-	■	-	2/4	• Connection sizes for 1.02 in width: 1/4 NPT, QS-1/4-3/8-U, QS-1/4-5/16-U
C CK		NPT thread: VABV-S2-1S-N38-2T2	-	-	■	2/4	• Connection sizes for 1.65 in width: 3/8 NPT, QS-3/8-3/8-U, QS-3/8-1/2-U
Manifold subbase for multi-pin plug/fieldbus connection for single solenoid valves							
E EK		NPT thread: VABV-S4-2S-N18-2T1	■	-	-	2/2	• Connection sizes for 0.71 in width: 1/8 NPT, QS-1/8-5/16-U, QS-1/8-1/4-U
F FK		NPT thread: VABV-S4-1S-N14-2T1	-	■	-	2/2	• Connection sizes for 1.02 in width: 1/4 NPT, QS-1/4-3/8-U, QS-1/4-5/16-U
G GK		NPT thread: VABV-S2-1S-N38-2T1	-	-	■	2/2	• Connection sizes for 1.65 in width: 3/8 NPT, QS-3/8-3/8-U, QS-3/8-1/2-U

Manifold Subbase Variants – Type 45 VTSA-F							
Code	Image	Type	Width		No. of valve positions/solenoid coils	Working ports (2, 4) on manifold subbase	
			0.71 in	1.02 in			
Manifold subbase for multi-pin plug/fieldbus connection for double solenoid valves							
A AK		NPT thread: VABV-S4-2HS-N18-2T2	■	-	2/4	• Connection sizes for 0.71 in width: 1/8 NPT, QS-1/8-5/16-U, QS-1/8-1/4-U	
B BK		NPT thread: VABV-S4-1HS-N14-2T2	-	■	2/4	• Connection sizes for 1.02 in width: 1/4 NPT, QS-1/4-3/8-U, QS-1/4-5/16-U	
Manifold subbase for multi-pin plug/fieldbus connection for single solenoid valves							
E EK		NPT thread: VABV-S4-2HS-N18-2T1	■	-	2/2	• Connection sizes for 0.71 in width: 1/8 NPT, QS-1/8-5/16-U, QS-1/8-1/4-U	
F FK		NPT thread: VABV-S4-1HS-N14-2T1	-	■	2/2	• Connection sizes for 1.02 in width: 1/4 NPT, QS-1/4-3/8-U, QS-1/4-5/16-U	

Pneumatic Components

Valve Manifolds Type 44 VTSA, Type 45 VTSA-F – Inch Series

Compressed Air Supply and Venting

Right-hand end plate
– Code V

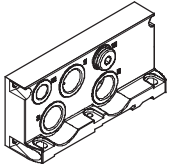

Port configuration for supply plates
Exhaust air 3/5 separated
– Code K

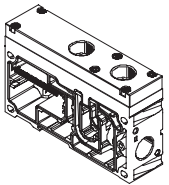

Right-hand end plate
– Code X

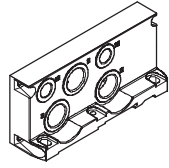

Port configuration for supply plates
Exhaust port 3/5 common
– Code L

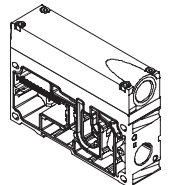

End plate with pilot air selector
– Code Y, U, Z, W

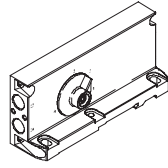

The valve manifold VTSA/VTSA-F can be supplied with compressed air at one or more points. This is a reliable way of ensuring that all functional components of the manifold will always offer good performance, even with large-scale expansions. The valve manifold is supplied via supply plates (max. 16 per manifold) or via an end plate. Venting is performed either using silencers or ports for ducted exhaust air on the supply plates and/or on the right-hand end plate. There are two types of supply plates:

- Exhaust port 3/5 common
- Exhaust 3/5 port separated

Pilot air supply

The port for the pneumatic supply is located on the supply plates or the right-hand end plate. The ports differ for the following types of pilot air supply:

- Internal
- External

Internal pilot air supply

Internal pilot air supply can be selected if the required working pressure is between 44 and 147 psi. The pilot air supply is then branched from the compressed air supply 1 using an internal connection. Port 14 on the right-hand end plate is sealed with a blanking plug.

External pilot air supply

If the supply pressure is less than 44 psi, you must operate your valve manifold using external pilot air supply. The pilot air supply is supplied via port 14 on the right-hand end plate to this end. This is the case even if the valve manifold is operated with different pressure zones.

Note

If a gradual pressure build-up in the system using a pressurized on-off valve is required, external pilot supply air where the control pressure applied during switch-on is already very high should be selected.

Right-hand End Plate

Different right-hand end plates are available.

With the following two end plates, the outgoing direction of the ports is aligned with the horizontal stacking direction.

Right-hand end plates with supply air/exhaust air

- Internal pilot air supply: Code V
- External pilot air supply: Code X

For end plates with pilot air selector, the outgoing direction of the ports is to the front face of the valve manifold. This means that all of the ports on the manifold can be combined in one outgoing direction.

The special feature of the end plates with pilot air selector is the selector switch itself, which has four settings for different pilot air supply/pilot exhaust air.

End plates with pilot air selector switch set at the factory for:

- Internal pilot air supply: Code Y
- External pilot air supply: Code Z
- Internal pilot air supply, ducted pilot exhaust air: Code U
- External pilot air supply, ducted pilot exhaust air: Code W

Note

The end plate with pilot air selector must be used in combination with a supply plate. The reversible 3/2-way valves (code P, Q, R) must only be operated in selector position 1 or 2 (code Z, Y).

Right-hand End Plate with Coding Cap

Code	Selector position
Z	1
Y	2
W	3
U	4

Pneumatic Components

Valve Manifolds Type 44 VTSA, Type 45 VTSA-F – Inch Series

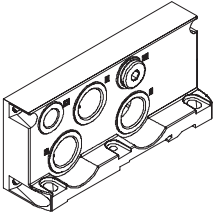
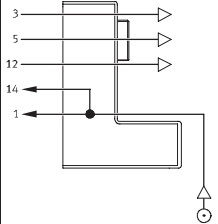
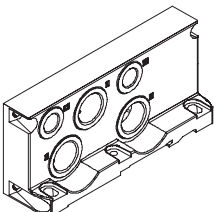
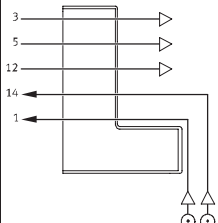
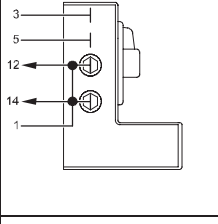
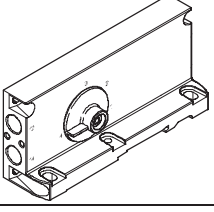
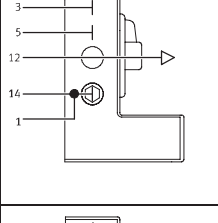
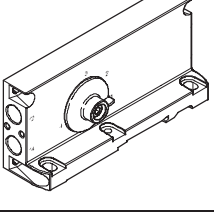
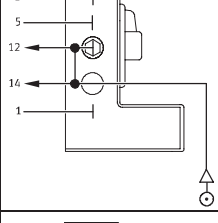
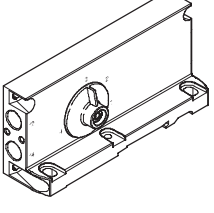
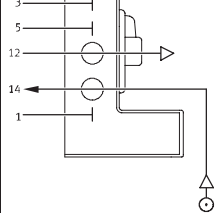

Right-hand End Plate						
Code	Type of compressed air supply and pilot air supply	Width			Description	
		0.71 in	1.02 in	1.65 in		
Right-hand end plate						
V			■	■	■	Supply air/exhaust air, internal pilot air supply, silencer <ul style="list-style-type: none"> • Pilot air supply is branched internally from port 1 • Port 14 is sealed with a blanking plug • Exhaust 3/5 via silencer • For operating pressure in the range 44 ... 147 psi • Pilot exhaust¹⁾
X			■	■	■	Supply air/exhaust air, external pilot air supply, silencer <ul style="list-style-type: none"> • Pilot air supply between 2 and 10 bar is connected at port 14 • Exhaust 3/5 via silencer • For operating pressure in the range -13.2 ... 147 psi (suitable for vacuum) • Pilot exhaust¹⁾
Code ²⁾	End plate with pilot air selector					
Y (2)			■	■	■	Internal pilot air supply <ul style="list-style-type: none"> • Pilot air supply is branched internally from port 1 • Ports 1/12/14 are internally connected • Ports 12/14 are sealed with blanking plugs • Pilot exhaust air is vented via valve housing
U (4)			■	■	■	Internal pilot supply air, ducted exhaust air <ul style="list-style-type: none"> • Pilot air supply is branched internally from port 1 • Ports 1/14 are internally connected • Port 14 is sealed with a blanking plug • Pilot exhaust via port 12 with silencer¹⁾
Z (1)			■	■	■	External pilot air supply <ul style="list-style-type: none"> • Pilot air supply is connected at port 14 • Port 12 is sealed with a blanking plug • Ports 12/14 are internally connected • Pilot exhaust air is vented via valve housing
W (3)			■	■	■	External pilot supply air, ducted exhaust air <ul style="list-style-type: none"> • Pilot air supply is connected at port 14 • Pilot exhaust via port 12 with silencer¹⁾

1) Ducted pilot exhaust air is only possible with turned seals on the valve
 2) Selector position in brackets

Pneumatic Components

Valve Manifolds Type 44 VTSA, Type 45 VTSA-F – Inch Series



Compressed Air Supply/Duct Separation

Additional supply plates can be used for larger manifolds or to create pressure zones.

These can be selected at any point before or after manifold subbases.

Supply plates contain the ports:

- Compressed air supply port (1)
- Exhaust port (3/5) common or separated

Depending on your order, the exhaust air ducts are either ducted or vented via silencers.

VTSA/VTSA-F with ducted exhaust air

With ducted exhaust air, venting can be performed via a supply plate or a right-hand end plate (code V or X).

If a duct separation is required, there are three different options:

- Duct separation 1, 3, 5: Code S
- Duct separation 1: Code T
- Duct separation 3, 5: Code R

If a combination of duct separation (S, T or R) and one or two supply plates is required, the following variants can be selected:

- Supply plate with duct separation on the left-hand side:
Code SU, TU, RU
- Supply plate with duct separation on the right-hand side:
Code US, UT, UR
- 2 supply plates with intermediate duct separation:
Code USU, UTU, URU

Supply Plates						
Code	Image	Type	Width			Description
			0.71 in	1.02 in	1.65 in	
U		<ul style="list-style-type: none"> • Exhaust port 3/5 common For NPT thread: VABF-S6-10-P1A7-N12 • Exhaust air 3/5 separated For NPT thread: VABF-S6-10-P1A6-N12 	■	■	■	Supply plate without duct separation (no R, S or T selected)
SU TU RU			■	■	■	Supply plate with duct separation on left, if R, S or T selected
US UT UR			■	■	■	Supply plate with duct separation on right, if R, S or T selected
USU UTU URU			■	■	■	2 supply plates with duct separation in centre, if R, S or T selected

Pneumatic Components

Valve Manifolds Type 44 VTSA, Type 45 VTSA-F – Inch Series



Configuration of All Pneumatic Connections with NPT Thread											
Code ¹⁾			Connection	Designation	Code M Push-in connector large	Code N Push-in connector small					
V		-	Right-hand end plate, internal pilot air supply, silencer								
			1	Compressed air/ vacuum supply	Push-in fitting	QS-1/2-5/8-U	QS-1/2-1/2-U				
			3/5	Exhaust air	Via silencer	U-1/2-B-NPT	U-1/2-B-NPT				
			14	Pilot air supply	Blanking plug	B-1/4-NPT	B-1/4-NPT				
X		-	Right-hand end plate, external pilot air supply, silencer								
			1	Compressed air/ vacuum supply	Push-in fitting	QS-1/2-5/8-U	QS-1/2-1/2-U				
			3/5	Exhaust air	Via silencer	U-1/2-B-NPT	U-1/2-B-NPT				
			12	Pilot exhaust air	Via silencer	U-1/4-B-NPT	U-1/4-B-NPT				
Y (2)			End plate with pilot air selector, internal pilot air supply								
			12/14	Pilot air supply/ pilot exhaust air	Blanking plug/push-in fitting	B-1/4-NPT / QS-1/4-3/8-U	B-1/4-NPT / QS-1/4-5/16-U				
			U (4)			End plate with pilot air selector, internal pilot air supply, ducted exhaust air					
						12/14	Pilot air supply/ pilot exhaust air	Blanking plug/blanking plug	B-1/4-NPT / B-1/4-NPT	B-1/4-NPT / B-1/4-NPT	
Z (1)			End plate with pilot air selector, external pilot air supply								
			12/14	Pilot air supply/ pilot exhaust air	Push-in fitting or silencer/push-in fitting	QS-1/4-3/8-U or U-1/4-B-NPT / QS-1/4-3/8-U	QS-1/4-5/16-U or U-1/4-B-NPT / QS-1/4-5/16-U				
W (3)			End plate with pilot air selector, external pilot air supply, ducted exhaust air								
			12/14	Pilot air supply/ pilot exhaust air	Push-in fitting or silencer/blanking plug	QS-1/4-3/8-U or U-1/4-B-NPT / B-1/4-NPT	QS-1/4-5/16-U or U-1/4-B-NPT / B-1/4-NPT				

1) Selektor position in brackets.

Pneumatic Components

Valve Manifolds Type 44 VTSA, Type 45 VTSA-F – Inch Series

Creation of Pressure Zones and Separation of Exhaust Air

The valve manifold VTSA/VTSA-F offers a number of options for creating pressure zones if different working pressures are required.

Pressure zones are created by isolating the internal supply ducts between the manifold subbases using an appropriate duct separation.

Compressed air is supplied and vented by using a supply plate.

The position of the supply plates and duct separations can be freely selected for VTSA/VTSA-F.

Duct separations are integrated ex-works as per your order.

Duct order and separations can be distinguished by their coding, even when the valve manifold is assembled.

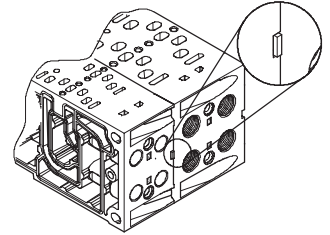

Creating Pressure Zones						
Code	Separating seal		Width			Description
	Pictorial examples	Coding	0.71 in	1.02 in	1.65 in	
T			■	■	■	Duct 1 separated
S			■	■	■	Duct 1 and 3/5 separated
R			■	■	■	Duct 3/5 separated

Pneumatic Components

Valve Manifolds Type 44 VTSA, Type 45 VTSA-F – Inch Series



Examples: Compressed Air Supply and Pilot Air Supply, Right-hand End Plate

Internal pilot air supply, silencer/ducted exhaust air

Right-hand end plate
Code V

The diagram opposite shows an example for the configuration and connection of the compressed air supply with internal pilot supply air. Port 14 on the right-hand end plate is tightly sealed. Exhaust air 3/5 is drawn off via the silencer. Duct separations can be used optionally to create pressure zones.

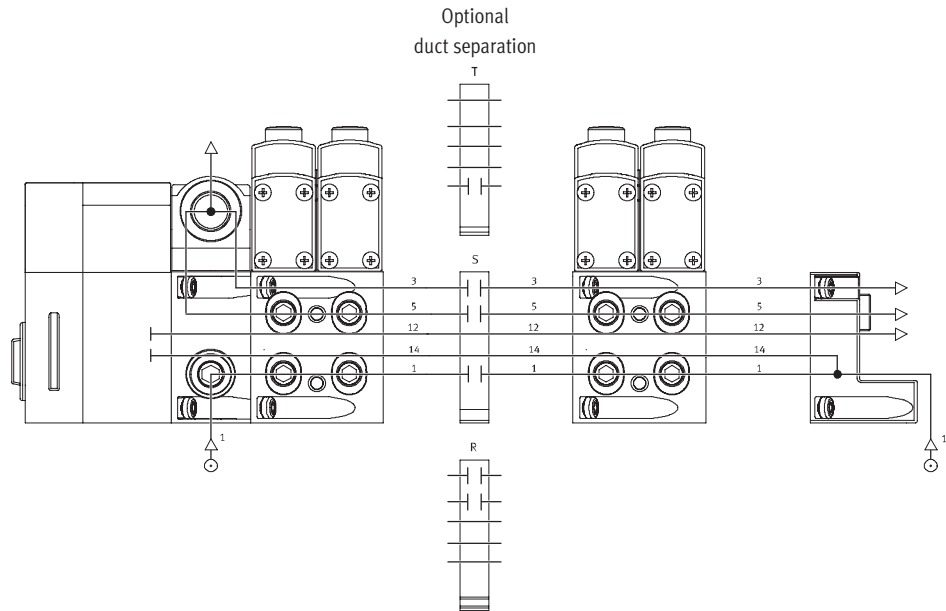

External pilot air supply, silencer/ducted exhaust air

Right-hand end plate
Code X

The diagram opposite shows an example for the configuration and connection of the compressed air supply with external pilot supply air. Port 14 on the right-hand end plate is equipped with a fitting for this. Exhaust air 3/5 is drawn off via the silencer. Duct separations can be used optionally to create pressure zones.

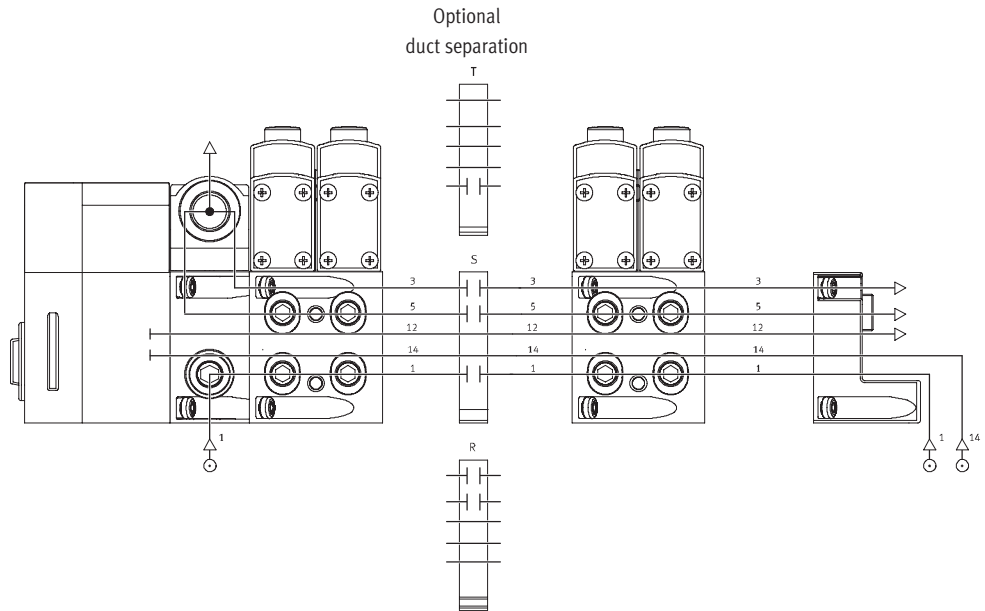

Pneumatic Components

Valve Manifolds Type 44 VTSA, Type 45 VTSA-F – Inch Series



Examples: Compressed Air Supply and Pilot Air Supply via End Plate with Pilot Air Selector

Internal pilot air supply, ducted exhaust air/silencer

Right-hand end plate
Code Y, U – code U shown

The diagram opposite shows an example for the configuration and connection of the compressed air supply with internal pilot supply air. Port 14 on the right-hand end plate is tightly sealed. Exhaust air 3/5 is ducted or drawn off via the silencer. Duct separations can be used optionally to create pressure zones.

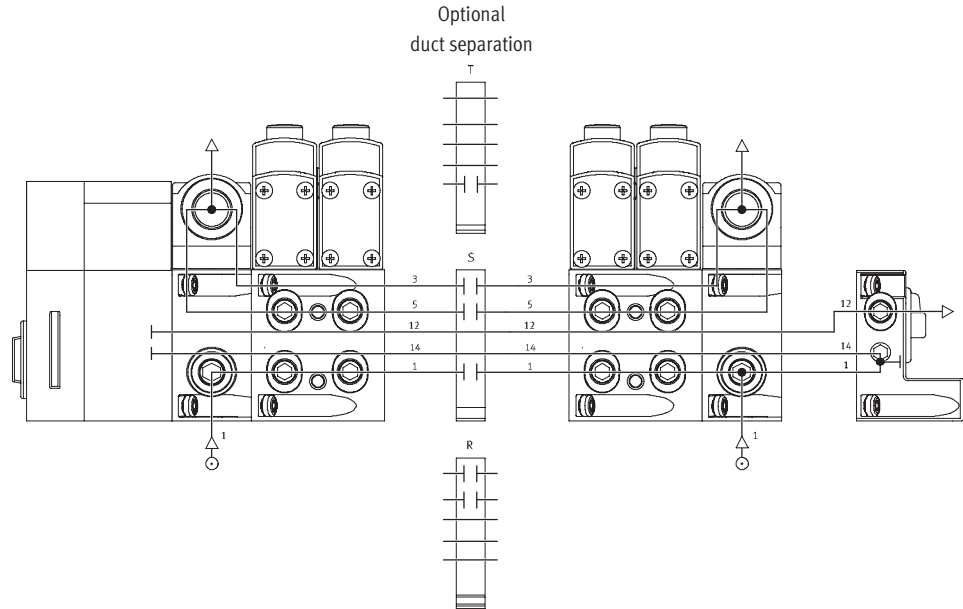

External pilot air supply, ducted exhaust air/silencer

Right-hand end plate
Code Z, W – code Z shown

The diagram opposite shows an example for the configuration and connection of the compressed air supply with external pilot supply air. Port 14 on the right-hand end plate is equipped with a fitting for this. Exhaust air 3/5 is ducted or drawn off via the silencer. Duct separations can be used optionally to create pressure zones.

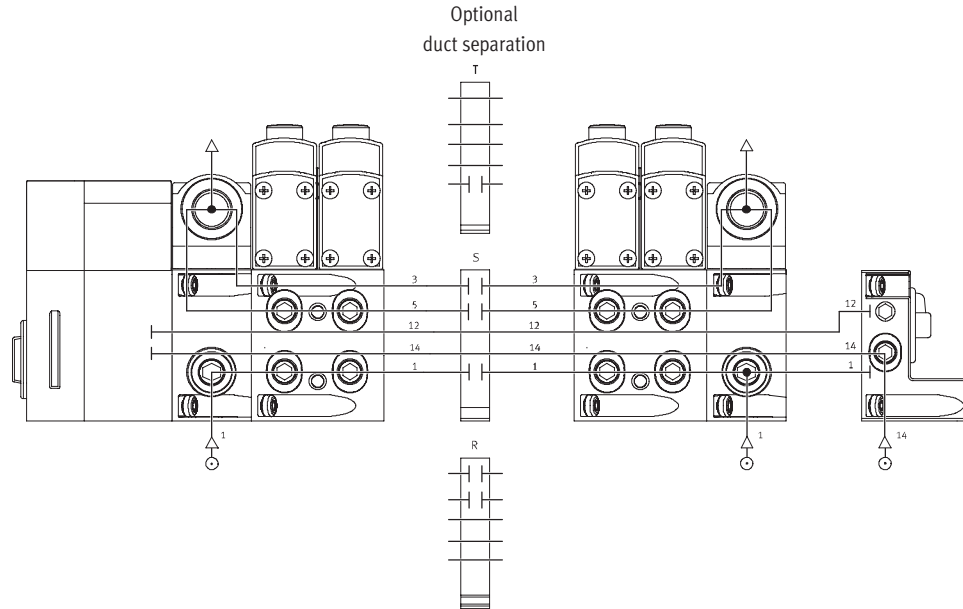

Pneumatic Components

Valve Manifolds Type 44 VTSA, Type 45 VTSA-F – Inch Series



Examples: Creation of Pressure Zones

VTSA/VTSA-F with CPX manifold connection

VTSA/VTSA-F allows the creation of up to 16 pressure zones (32 pressure zones if only size 1 (1.65 in), ISO 5599-2, is fitted). The diagram shows an example for the configuration and connection of three pressure zones using duct separations – with internal pilot air supply.

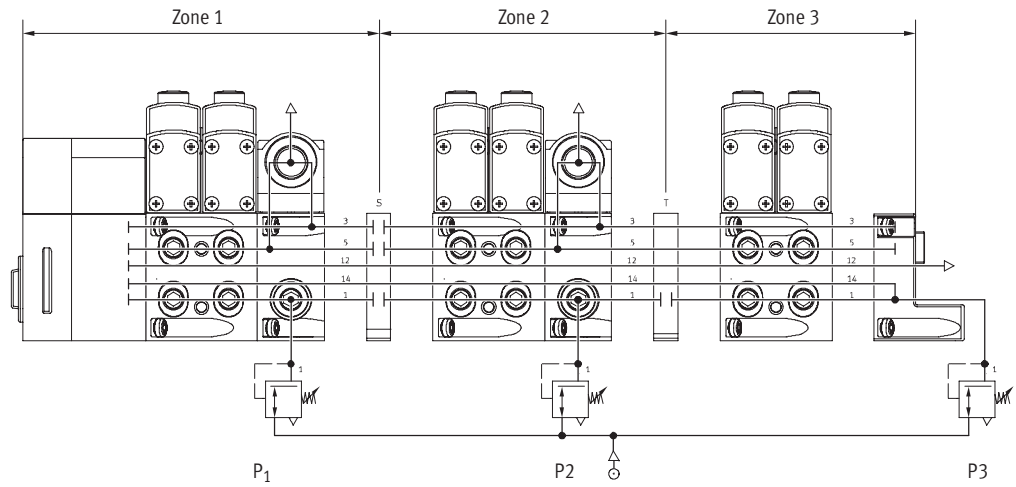

Electrical Components

Valve Manifolds Type 44 VTSA, Type 45 VTSA-F – Inch Series

Protective Circuit

Each VTSA/VTSA-F solenoid coil is protected with a spark arresting protective circuit as well as against reverse-polarity protection.

24 V DC version

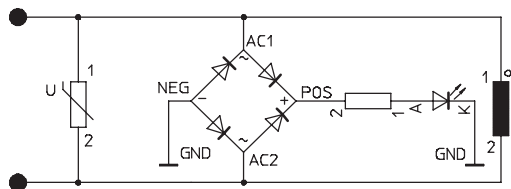

110 V AC version

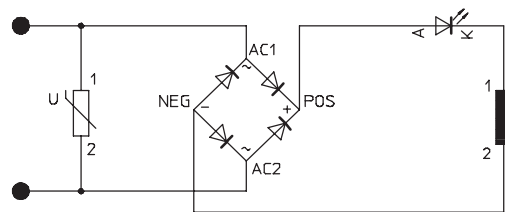

Individual Valve

Valves can also be used on individual subbases for actuators further away from the valve manifold.

- Electrical M12 connector, 4 pin 24 V DC
- Screw terminal connection for configuration by the user 24 V DC or 110 V AC

Electrical Connection, Individual Valve 24 V DC

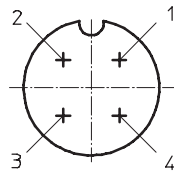
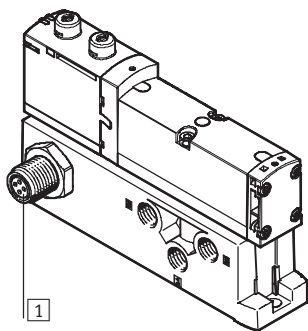

1 Connector plug M12x1, male, 4-pin to EN 61076-2-101

Pin allocation M12 on individual valve to ISO 20401

With positive logic:

- Pin1 – Not allocated
- Pin2 – 24 V DC for coil 12
- Pin3 – 0 V for coil 12 and 14 or
- Pin4 – 24 V DC for coil 14

With negative logic:

- Pin1 – Not allocated
- Pin2 – 0 V for coil 12
- Pin3 – 24 V DC for coil 12 and 14
- Pin4 – 0 V for coil 14

Electrical Connection, Individual Valve, 24 V DC or 110 V AC

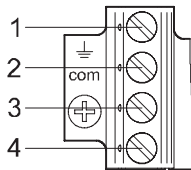
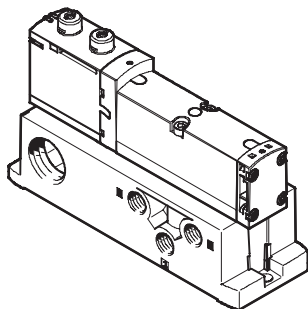

Terminal allocation for assembly by the user

With positive logic:

- 1 – Unused (with 110 V AC connection for earthing)
- 2 – 24 V DC for coil 12
- 3 – 0 V for coil 12 and 14
- 4 – 24 V DC for coil 14

With negative logic:

- 1 – Unused
- 2 – 0 V for coil 12
- 3 – 24 V DC for coil 12 and 14
- 4 – 0 V for coil 14

Electrical Components

Valve Manifolds Type 44 VTSA, Type 45 VTSA-F – Inch Series

Fieldbus Connection/Control Block

All functions and features of the electrical peripherals CPX are permitted in connection with the CPX interface. This means:

- The valves and electrical outputs are supplied via the operating voltage connection of the CPX.
- The valves are supplied and switched independently via a separate port on the CPX.

Note

Further information can be found in www.festo.com/catalog/cpx

Electrical Multi-pin Plug Connection

The following multi-pin plug connection variants are offered for the valve manifold VTSA:

- Individual electrical connection M12 (5-pin M12 for 24 V DC): 6 or 10 M12 connectors allowing for 2 solenoids to be activated per connection.
- Sub-D multi-pin plug connection (37-pin for 24 V DC): A maximum of 32 solenoids can be

activated. The manifold is available with up to 32 single solenoid valves, 16 double solenoid valves, or a combination of up to 32 solenoids.

- Terminal box (cage clamp terminal strip for 24 V DC or 110 V AC): A maximum of 32 solenoids can be activated. The manifold is available with up to 32 single solenoid valves, 16 double solenoid valves, or a combination of up to 32 solenoids.

Each pin on the Sub-D multi-pin plug or terminal box can activate exactly a single solenoid coil.

If the maximum configurable number of valve positions is 32, this means that 32 valves can be addressed via a single solenoid coil.

With 16 or less valve positions, 2 valve solenoid coils per valve can be addressed.

Note

Use the following 37-pin connecting cables from Festo to connect the valve manifold with Sub-D multi-pin plug connection:

- NEBV-S1W37-...-LE10 for max. 8 solenoid coils
- NEBV-S1W37-...-LE26 for max. 22 solenoid coils
- NEBV-S1W37-...-LE37 for max. 32 solenoid coils
- NECV-S1W37 pre-assembled plug connector

Individual Electrical Connection, 6-way Code MP2, or 10-way Code MP3, 24 V DC

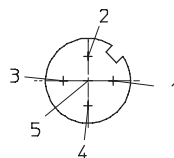
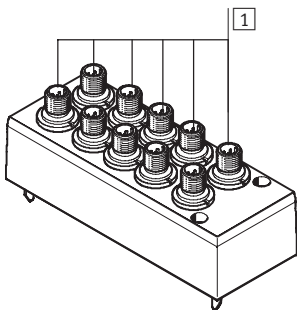

1 Connector plug M12x1, male, 5-pin

Pin allocation M12

- Pin1 – Unused
- Pin2 – 24 V DC for coil 12
- Pin3 – 0 V for coil 12 and 14
- Pin4 – 24 V DC for coil 14
- Pin5 – Functional earth

Electrical Components

Valve Manifolds Type 44 VTSA, Type 45 VTSA-F – Inch Series



Pin Allocation – Terminal Box (CageClamp), 24 V DC and 110 V AC; Electrical Connection Code T				
	Manifold	Coil/address	Manifold	Coil/address
<p>Each solenoid coil must be assigned to a specific terminal on the terminal strip in order for actuation of the valves to take place.</p>	1	0	17	16
	2	1	18	17
	3	2	19	18
	4	3	20	19
	5	4	21	20
	6	5	22	21
	7	6	23	22
	8	7	24	23
	9	8	25	24
	10	9	26	25
	11	10	27	26
	12	11	28	27
	13	12	29	28
	14	13	30	29
	15	14	31	30
	16	15	32	31
	<p>Note The drawing shows the view onto the terminal strip (CageClamp).</p>	Conductor		
33		0 V	35	0 V
34		0 V	36	0 V

1) 0 V for positive switching control signals; connect 24 V for negative switching control signals; mixed operation is not permitted.

Sub-D plug, 24 V DC; Electrical Connection Code MP1							
Type	Sheath	Length [ft]	Wire x mm ² [mm ²]	Cable Ø [in]	Part No.		
NEBV-S1W37-E2,5-LE10	Polyurethane (PUR)	8.2	10 x 0.34	0.30	539240		
NEBV-S1W37-E5-LE10		16.4			539241		
NEBV-S1W37-E10-LE10		32.8			539242		
NEBV-S1W37-E2,5-LE26		8.2	26 x 0.34		0.45	539243	
NEBV-S1W37-E5-LE26		16.4				539244	
NEBV-S1W37-E10-LE26		32.8				539245	
NEBV-S1W37-K2,5-LE37		8.2	37 x 0.34			0.51	539246
NEBV-S1W37-K5-LE37		16.4					539247
NEBV-S1W37-K10-LE37		32.8					539248
NEBV-S1W37-KM-2,5-LE10	Polyvinyl chloride (PVC)	8.2	10 x 0.34	0.30			543271
NEBV-S1W37-KM-5-LE10		16.4					543272
NEBV-S1W37-KM-10-LE10		32.8					543273
NEBV-S1W37-KM-2,5-LE27		8.2	27 x 0.34		0.45		543274
NEBV-S1W37-KM-5-LE27		16.4					543275
NEBV-S1W37-KM-10-LE27		32.8					543276
NEBV-S1W37-KM-2,5-LE37		8.2	37 x 0.34			0.51	543277
NEBV-S1W37-KM-5-LE37		16.4					543278
NEBV-S1W37-KM-10-LE37		32.8					543279

Electrical Components

Valve Manifolds Type 44 VTSA, Type 45 VTSA-F – Inch Series



Pin Allocation – Sub-D Plug Socket, 24 V DC; Electrical Connection Code MP1						
	Pin ²⁾	Address/coil	Core color ¹⁾	Pin ²⁾	Address/coil	Core color ¹⁾
	1	0	WH	17	16	WH PK
	2	1	BN	18	17	PK BN
	3	2	GN	19	18	WH BU
	4	3	YE	20	19	BN BU
	5	4	GY	21	20	WH RD
	6	5	PK	22	21	BN RD
	7	6	BU	23	22	GY GN
	8	7	RD	24	23	YE GY
	9	8	GY PK	25	24	PK GN
	10	9	RD BU	26	25	YE PK
	11	10	WH GN	27	26	GN BU
	12	11	BN GN	28	27	YE BU
	13	12	WH YE	29	28	GN RD
	14	13	YE BN	30	29	YE RD
	15	14	WH GY	31	30	GN BK
	16	15	GY BN	32	31	GY BU
Note The drawing shows the view onto the Sub-D plug socket at the multi-core cable NEBV-S1W37-....	Conductor					
	33	0 V ³⁾	YE BK	35	0 V ³⁾	BN BK
	34	0 V ³⁾	WH BK	36	0 V ³⁾	BK
	Earthing					
	37	FE (earth)	VT	–	–	–

- 1) To IEC 757
- 2) Pin 9 ... 35: Not available with cable NEBV-S1-W37-...-10
Pin 23 ... 33: Not available with cable NEBV-S1-W37-...-26
- 3) 0 V for positive switching control signals; connect 24 V for negative switching control signals; mixed operation is not permitted.

Dimensions⁴⁾

Download CAD Data → www.festo.com/us/cad

Multi-pin cable NEBV-S1W37-....

1 Cable conduit fitting M20x1.5

The wire colors refer to the following pre-assembled multi-core cables from Festo:

- NEBV-S1W37-...-10 for valve manifold with max. 8 solenoid coils
- NEBV-S1W37-...-26 for valve manifold with max. 22 solenoid coils
- NEBV-S1W37-...-37 for valve manifold with max. 32 solenoid coils

4) Dimensions are in inches, unless otherwise noted.

Electrical Components

Valve Manifolds Type 44 VTSA, Type 45 VTSA-F – Inch Series

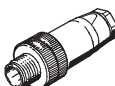
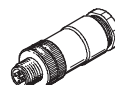
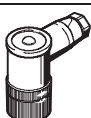
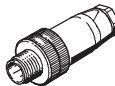
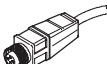
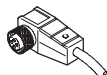
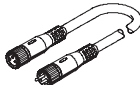

Electrical Connection Technology				
	Electrical connection	Type of mounting/cable length	Type	Part No.
Sensor plug/socket for inputs/outputs				
	Straight plug, 4-pin, screw manifold	Threaded connector M12	SEA-GS-7	18666
			SEA-GS-9	18778
			SEA-GS-11-DUO	18779
	Plug socket, angled, 4-pin, screw manifold	Union nut M12	SEA-M12-4WD-PG7	185498
	Straight plug, 4-pin, screw manifold	Threaded connector M12	SEA-4GS-7-2,5	192008
Plug socket with cable for connecting individual valves or sensors				
	Straight socket, 4-pin, M12	16.4 ft	SIM-M12-4GD-5-PU	164259
	Angled socket, 4-pin, M12	16.4 ft	SIM-M12-4WD-5-PU	164258
	Modular system for connecting cables	–	NEBU-... → www.festo.com/catalog/nebu	–

Installation and Operation

Valve Manifolds Type 44 VTSA, Type 45 VTSA-F – Inch Series

Valve Manifold Assembly

Sturdy manifold attachment thanks to:

- Four through-holes for wall mounting
- Additional mounting bracket
- H-rail mounting

Wall mounting

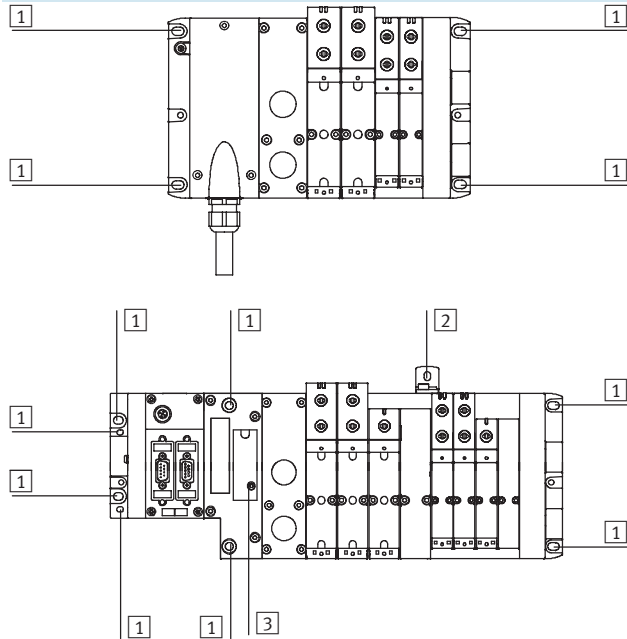

The VTSA/VTSA-F valve manifold is screwed onto the mounting surface using M6 screws. The mounting holes are located at the following points:

- Multi-pin plug (4 pieces):
2 each at the multi-pin connection block and the right-hand end plate
 - Fieldbus (4 pieces):
2 each at the left-hand (CPX) and right-hand (VTSA/VTSA-F) end plate.
- The pneumatic interface additionally provides further mounting holes as well as optional mounting brackets.

The fieldbus version additionally provides a bracket for wall mounting (Part No. 665983). The mounting brackets can be used with very long valve manifolds (6 manifold subbases or more) to improve load capacity during vibration or shocks.

- 1 Hole for M6 screw
- 2 Hole for M5 screw
- 3 Hole for DIN H-rail mounting

DIN H-rail mounting

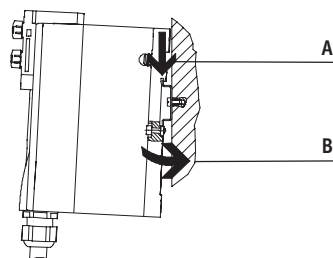

The VTSA/VTSA-F valve manifold is hooked onto the DIN H-rail (see arrow A). It is then swivelled about the DIN H-rail, then swung into place and secured with the clamping shim (see arrow B).

For DIN H-rail mounting of the valve manifold you will need the following VTSA/VTSA-F mounting kit:

- With multi-pin plug:
CPA-BG-NRH
- With fieldbus:
CPX-CPA-BG-NRH

This permits mounting of the valve manifold on a DIN H-rail to EN 60715.

Individual Valve Assembly

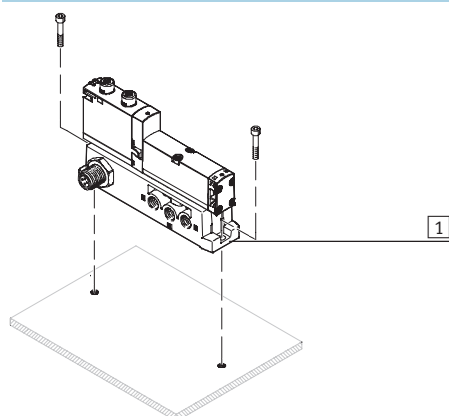

- 1 Vertical mounting holes

The individual manifold block is designed for wall mounting for integration into a system or machine. It is mounted vertically.

Installation and Operation

Valve Manifolds Type 44 VTSA, Type 45 VTSA-F – Inch Series

Display and Operation

Each solenoid coil is allocated an LED which indicates its switching status.

- Indicator 12 shows the switching status of the pilot control for output 2
- Indicator 14 shows the switching status of the pilot control for output 4

Manual override

The manual override allows the valve to be switched when in the electrically non-activated or de-energized status.

The valve is actuated by pushing the manual override. The set switching status can also be secured by turning the manual override.

Alternatives:

- A cover cap (accessory code N) can be fitted over the manual override to prevent it from being turned. The valve can then only be actuated by pressing it.
- A cover cap (accessory code V) can be fitted over the manual override to prevent it from being accidentally actuated.

Pneumatic connection and control elements

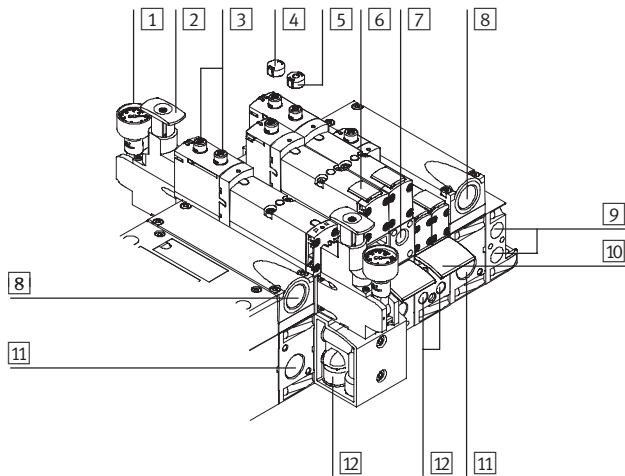

- | | |
|--|---|
| <ul style="list-style-type: none"> 1 Pressure gauge (optional) 2 Adjusting knob of optional pressure regulating plate 3 Manual override (for each pilot solenoid coil, pushing or pushing/detenting) 4 Optional cover cap for manual override (inhibits manual override) 5 Optional cover for manual override with non-detenting pushing function 6 Inscription label holder for valve 7 Adjusting screw of optional flow control plate 8 Exhaust ports (valves) (3/5) | <ul style="list-style-type: none"> 9 Pilot ports 12 and 14 for supplying the external pilot air supply 10 Inscription label holder for manifold block 11 Supply port 1 (operating pressure) 12 Working ports 2 and 4, for each valve position |
|--|---|

Note
A manually actuated valve (manual override) cannot be reset electrically. Conversely, an electrically actuated valve cannot be reset using the mechanical manual override.

Electrical connection and display components

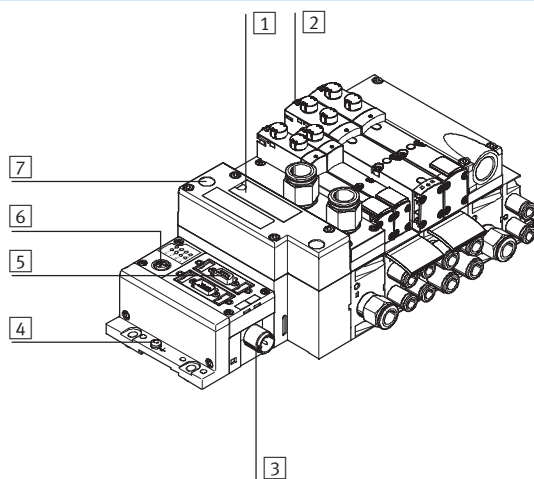

- 1 Inscription area and cover for DIN H-rail mounting
- 2 Yellow LEDs: Signal status display for pilot solenoid coils
- 3 Voltage supply connection
- 4 Earth manifold
- 5 Fieldbus connection (bus-specific)
- 6 Service interface for handheld unit, etc.
- 7 Red LED: Common fault display for valves

Installation and Operation

Valve Manifolds Type 44 VTSA, Type 45 VTSA-F – Inch Series



Manual Override (MO)

Manual override with automatic return (pushing)

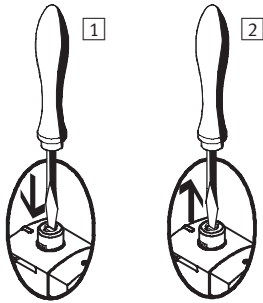

- 1 Press in the stem of the manual override using a pin or screwdriver. Valve is then actuated.
- 2 Remove the screwdriver. Spring force pushes the stem of the manual override back. Valve returns to the initial position (not with double solenoid valve code J).

Manual override set via turning (covered)

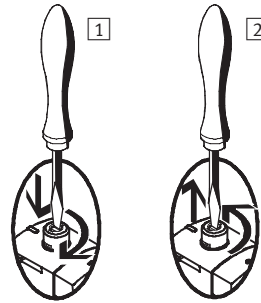

- 1 Press in the stem of the manual override using a pin or screwdriver until the valve switches and then turn the stem clockwise by 90° until the stop is reached. Valve remains actuated.
- 2 Turn the stem anti-clockwise by 90° until the stop is reached and then remove the screwdriver. Spring force pushes the stem of the manual override back. Valve returns to the initial position (not with double solenoid valve code J and D).

Inscription System

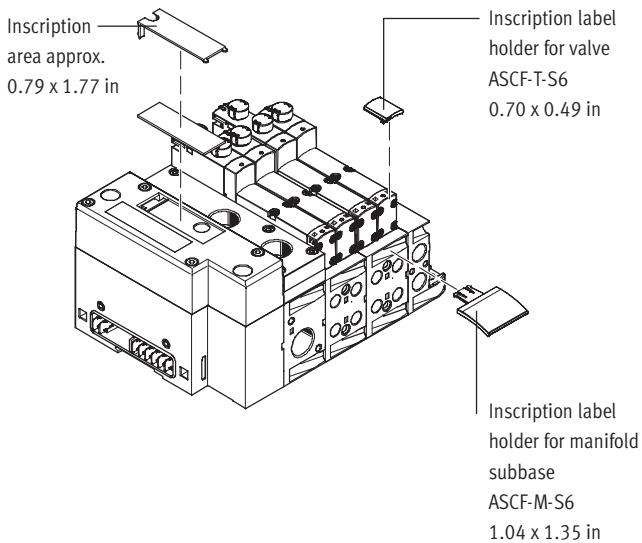

Inscription label holders can be applied to the valves and subbases to identify them. These inscription label holders can be ordered by entering the code B or T in the order code for accessories. Scope of delivery: Inscription label holder including inscription label. The following inscription labels can be used as spares:

- Inscription label holder for valve type ASCF-T-S6: Part No. 540888
 - Inscription label holder for manifold subbase type ASCF-M-S6: Part No. 540889
- Large inscription labels can be attached to the pneumatic interface as an alternative or in addition to the smaller labels.

Instructions for Use

Valve Manifolds Type 44 VTSA, Type 45 VTSA-F – Inch Series

Operate your equipment with unlubricated compressed air if possible. Festo valves and cylinders are designed for operation under normal use without any additional lubrication and still have a long service life.

The quality of compressed air downstream from the compressor must correspond to that of unlubricated compressed air. If possible, do not operate all of your equipment with lubricated compressed air. The lubricators should, where possible, always be installed directly upstream of the actuator used.

Unsuitable additional oil and an excessive oil content in the compressed air reduce the service life of the valve manifold.

Use Festo special oil OFSW-32 or the alternatives listed in the Festo catalog (as specified in DIN 51524 HLP32; basic oil viscosity 32 CST at 104 °F).

Bio-oils

When using bio-oils (oils which are based upon synthetic or native ester, e.g. rapeseed oil methyl ester), the maximum residual oil content of 0.1 mg/m³ must not be exceeded (see ISO 8573-1 Class 2).

Mineral oils

When using mineral oils (e.g. HLP oils to DIN 51524, parts 1 through 3) or similar oils based on poly-alpha-olefins (PAO), the maximum residual oil content of 5 mg/m³ must not be exceeded (see ISO 8573-1 Class 4).

A higher residual oil content irrespective of the compressor oil cannot be permitted, as the basic lubricant would be flushed out over time.

Technical Data

Valve Manifolds Type 44 VTSA, Type 45 VTSA-F – Inch Series

Flow rate

- Width 0.71 in: Up to 24.7 scfm
- Width 1.02 in: Up to 49.7 scfm
- Width 1.65 in: Up to 53.0 scfm

Valve width

- 02: 0.71 in (18 mm)
- 01: 1.02 in (26 mm)
- 1: 1.65 in (42 mm)

Voltage

- 24 V DC
- 110 V AC

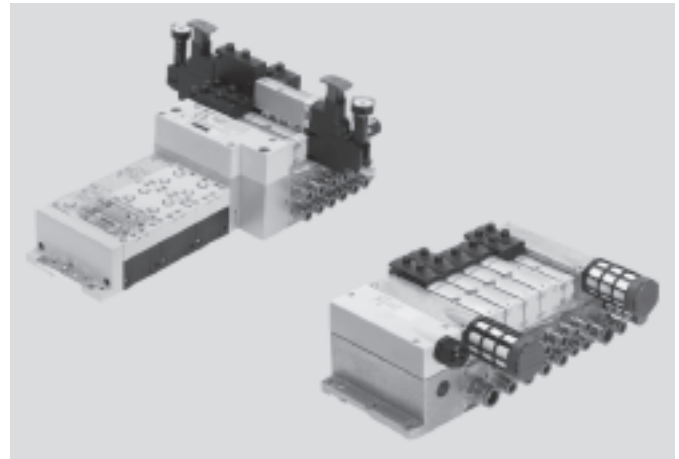

General Technical Data				
Width		0.71 in	1.02 in	1.65 in (type 44 VTSA only)
Design	Electromagnetically actuated piston spool valve			
Lubrication	Lubrication for life			
Type of mounting	Wall mounting			
	On DIN H-rail to EN 60715			
Mounting position	Any			
Manual override	Pushing, pushing/detenting, covered			
Pneumatic connections		NPT thread	NPT thread	NPT thread
Pneumatic connection	Via manifold subbase			
Supply port	1	1/2 NPT, QS-1/2-1/2-U, QS-1/2-5/8-U	1/2 NPT, QS-1/2-1/2-U, QS-1/2-5/8-U	1/2 NPT, QS-1/2-1/2-U, QS-1/2-5/8-U
Exhaust port	3/5	1/2 NPT, QS-1/2-1/2-U, QS-1/2-5/8-U	1/2 NPT, QS-1/2-1/2-U, QS-1/2-5/8-U	1/2 NPT, QS-1/2-1/2-U, QS-1/2-5/8-U
Working ports	2/4	1/8 NPT, QS-1/8-1/4-U, QS-1/8-3/16-U	1/4 NPT, QS-1/4-5/16-U, QS-1/4-3/8-U	3/8 NPT, QS-3/8-3/8-U, QS-3/8-1/2-U
Port for external pilot supply air	14	1/4 NPT	1/4 NPT	1/4 NPT
Pilot exhaust air port	12	1/4 NPT	1/4 NPT	1/4 NPT
Certification	CE			

Technical Data

Valve Manifolds Type 44 VTSA, Type 45 VTSA-F – Inch Series



Standard Nominal Flow Rate [scfm] – Type 44 VTSA													
Valve function order code	M	O	J	D	N	K	H	B	G	E	P	Q	R
Width 0.71 in													
Flow rate of valve	26.5				21.2			24.7 ¹⁾ 15.2 ²⁾		21.2			
Flow rate of valve on individual subbase	21.2				17.7			19.4 ¹⁾ 12.7 ²⁾		17.7			
Flow rate of valve on valve manifold	19.4				14.1			15.9 ¹⁾ 10.6 ²⁾		14.1			
Width 1.02 in													
Flow rate of valve	49.4				44.1			49.4 ¹⁾ 35.3 ²⁾		44.1			
Flow rate of valve on individual subbase	42.4				38.8			42.4 ¹⁾ 30.0 ²⁾		35.3			
Flow rate of valve on valve manifold	38.8				31.8			35.3 ¹⁾ 24.7 ²⁾		31.8			
Width 1.65 in													
Flow rate of valve	63.5				49.4			60.0 ¹⁾ 26.5 ²⁾		49.4			
Flow rate of valve on individual subbase	45.9				42.4			42.4 ¹⁾ 28.2 ²⁾		42.4			
Flow rate of valve on valve manifold	53.0				42.4			49.4 ¹⁾ 28.2 ²⁾		42.4			

1) Switching position

2) Mid-position

Standard Nominal Flow Rate [scfm] – Type 45 VTSA-F													
Valve function order code	M	O	J	D	N	K	H	B	G	E	P	Q	R
Width 0.71 in													
Flow rate of valve	26.5				21.2			17.7 ¹⁾ 11.6 ²⁾		21.2			
Flow rate of valve on valve manifold	24.7				19.4			17.7 ¹⁾ 11.6 ²⁾		19.4			
Width 1.02 in													
Flow rate of valve	49.4				44.1			49.4 ¹⁾ 24.7 ²⁾		44.1			
Flow rate of valve on valve manifold	47.7				40.6			47.7 ¹⁾ 24.7 ²⁾		40.6			

1) Switching position

2) Mid-position

Technical Data

Valve Manifolds Type 44 VTSA, Type 45 VTSA-F – Inch Series



Operating and Environmental Conditions			M	O	J	D	N	K	H	B	G	E	P	Q	R	
Valve function order code																
Operating medium			Filtered compressed air, lubricated or unlubricated, inert gases													
Grade of filtration			[μm]	40 (average pore size)												
Operating pressure	Pilot pressure		[psi]	44 ... 147												
	With internal pilot air		[psi]	44 ... 147												
	With external pilot air		[psi]	-13.2 ... +147				44 ... 147				-13.2 ... +147				
Ambient temperature			[$^{\circ}\text{F}$]	23 ... 122												
Temperature of medium			[$^{\circ}\text{F}$]	23 ... 122												
Storage temperature ¹⁾			[$^{\circ}\text{F}$]	-4 ... +104												
Relative air humidity			[%]	90												

1) Long-term storage

Pilot Pressure p12/14 as a Function of Operating Pressure p1

For 3/2-way valves

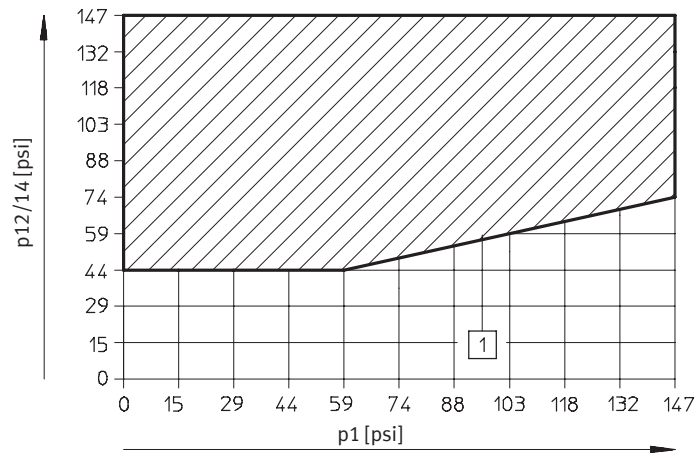

1) Operating range for valves with external pilot air supply

Valve Response Times [ms]		M	O	J	D	N	K	H	B	G	E	P	Q	R
18 mm														
Response times	on	22	12	-	-	12	12	12	15	15	15	25	25	25
	off	28	38	-	-	30	30	30	44	44	44	12	12	12
	changeover	-	-	11	11	-	-	-	22	22	22	-	-	-
26 mm														
Response times	on	25	20	-	-	20	20	20	22	22	22	32	32	32
	off	45	65	-	-	38	38	38	65	65	65	30	30	30
	changeover	-	-	18	18	-	-	-	33	33	33	-	-	-
42 mm (type 44 VTSA only)														
Response times	on	27	22	-	-	20	20	20	22	22	22	34	34	34
	off	45	60	-	-	38	38	38	65	65	65	28	28	28
	changeover	-	-	16	16	-	-	-	-	-	-	-	-	-

Technical Data

Valve Manifolds Type 44 VTSA, Type 45 VTSA-F – Inch Series



Flow Rate q_n as a Function of Output Pressure p_2 with Pressure Regulator Plates (P Regulator Plate) for Port 1

Width 0.71 in

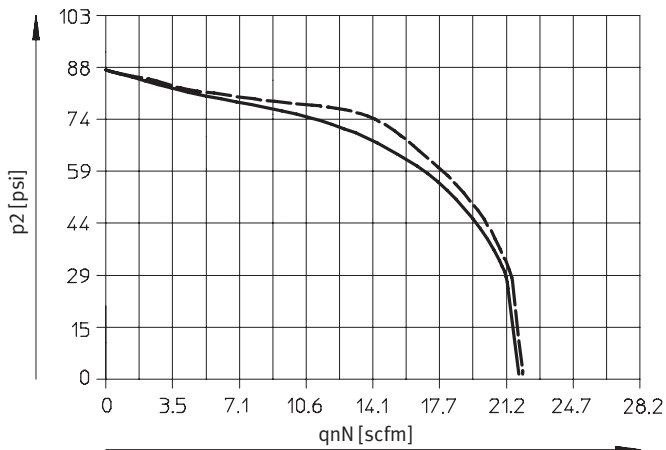

--- 88 psi
— 147 psi

Width 1.02 in

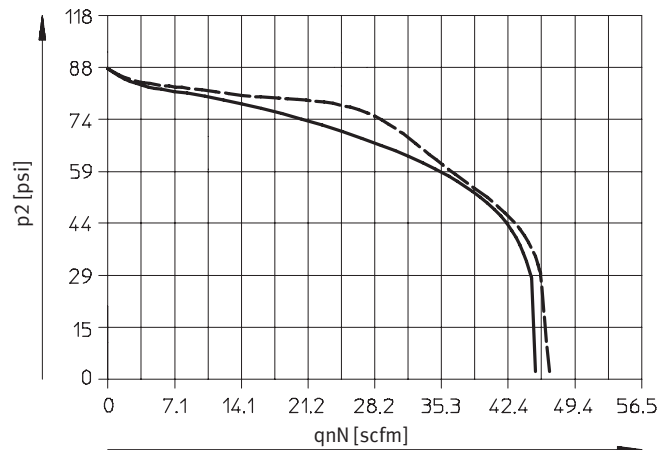

--- 88 psi
— 147 psi

Flow Rate q_n as a Function of Output Pressure p_2 with Pressure Regulator Plates (AB Regulator Plates) for Port 2, 4 or Ports 4/2

Width 0.71 in

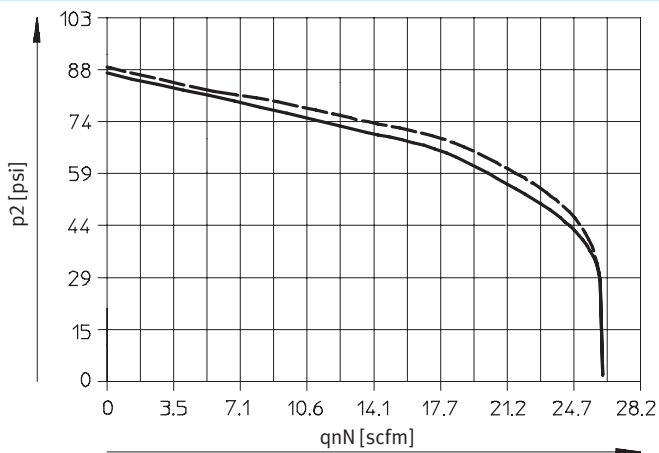

--- 88 psi
— 147 psi

Width 1.02 in

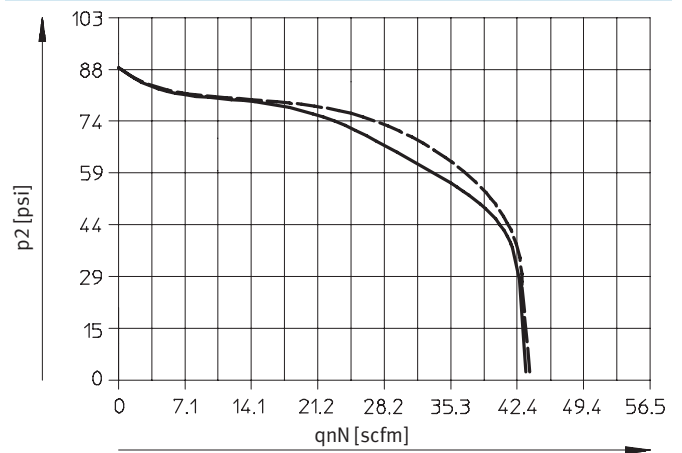

--- 88 psi
— 147 psi

Technical Data

Valve Manifolds Type 44 VTSA, Type 45 VTSA-F – Inch Series



Flow Rate q_n as a Function of Output Pressure p_2 with Pressure Regulator Plates (AB Regulator Plates, Rev.) for Ports 4/2, Reversible

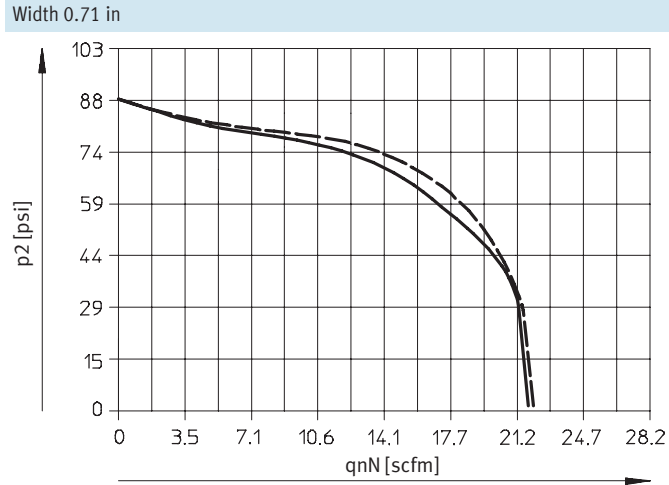

--- 88 psi
— 147 psi

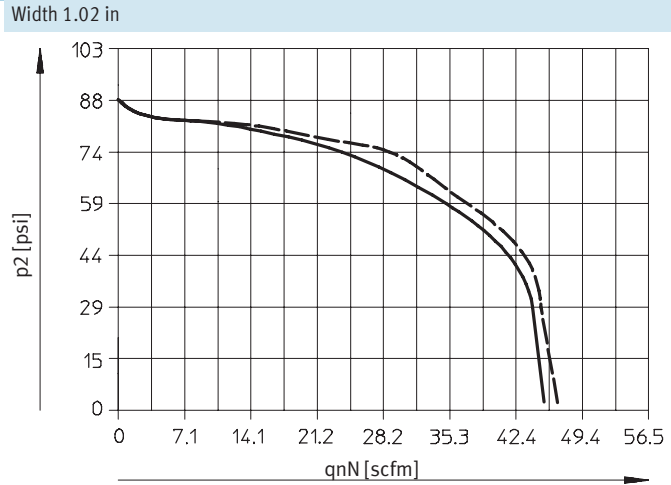

--- 88 psi
— 147 psi

Flow Rate q_n as a Function of Flow Control

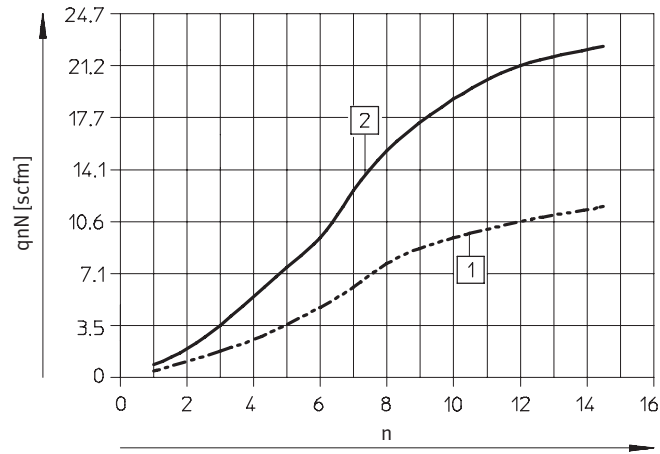

1 Width 0.71 in
2 Width 1.02 in
n Revolutions of the adjusting screw

Technical Data

Valve Manifolds Type 44 VTSA, Type 45 VTSA-F – Inch Series

Electrical Data – VTSA/VTSA-F with CPX Manifold			
	0.71 in	1.02 in	1.65 in (type 44 only)
Voltage supply for electronics/sensors (pin 1)			
Operating voltage [V]	24 DC ±10%		
Steady state current consumption at 24 V DC [mA]	20		
Duty cycle	100%		
Load voltage supply for valves (pin 2)			
Operating voltage [V]	24 DC ±10%		
Diagnostic message undervoltage V_{OFF} load voltage outside function range [V]	21.6 ... 21.5		
Protection class to EN 60529	IP65 (for all types of signal transmission in assembled state)		
Power consumption at 24 V DC			
2x 3/2-way valve [W]	1.3		
5/2-way valve, 5/3-way valve [W]	1.6		

Electrical Data – VTSA/VTSA-F with Multi-pin Plug Connection			
	0.71 in	1.02 in	1.65 in
Load voltage supply for valves			
Operating voltage [V]	24 DC ±10%		
	110 AC ±10% (50 ... 60 Hz)		
Duty cycle	100%		
Protection class to EN 60529	IP65 (for all types of signal transmission in assembled state), NEMA 4		
Power consumption at 24 V DC			
2x 3/2-way valve [W]	1.3		
5/2-way valve, 5/3-way valve [W]	1.6		
Power consumption at 110 V AC			
2x 3/2-way valve [VA]	1		
5/2-way valve, 5/3-way valve [VA]	1.6		

Technical Data

Valve Manifolds Type 44 VTSA, Type 45 VTSA-F – Inch Series



Materials			
	0.71 in	1.02 in	1.65 in
Manifold subbase	Die-cast aluminum		
Valve	Die-cast aluminum, reinforced polyamide		
Seals	Nitrile rubber, elastomer (support made of steel)		
Supply plate	Die-cast aluminum		
Right-hand end plate	Die-cast aluminum		
Left-hand pneumatic interface	Die-cast aluminum		
Flow control plate	Die-cast aluminum		
Pressure regulator plate	Die-cast aluminum, reinforced polyamide		
Multi-pin connection block	Die-cast aluminum		
Cover for the pneumatic interface and multi-pin plug connection	Wellamid, reinforced polyamide		

Product Weight [lb]			
	0.71 in	1.02 in	1.65 in (type 44 only)
Sub-D multi-pin interface module or manifold strip ¹⁾	1.21		
Interface module CPX ¹⁾	3.24		
Supply plate ²⁾			
• Exhaust plate with 3 and 5 common	1.36		
• Exhaust port cover with 3 and 5 separated	1.32		
Right-hand end plate ³⁾			
• Axial	0.75		
• Selector	0.62		
Manifold subbase ⁴⁾	0.99	1.40	0.75
90° connection plate ³⁾	0.37	0.51	0.39
Pressure regulator plate			
for port 1	0.77	0.89	1.41
for port 4 or 2	0.81	0.99	1.41
for ports 4/2	1.35	1.53	2.03
Flow control plate	0.50	0.71	0.49
Vertical supply plate ³⁾	0.31	0.42	0.75
Vertical shut-off plate	0.46	0.60	1.32
Valves			
• 5/3-way valve (code B, G, E)	0.42	0.71	1.01
• 5/2-way valve, single solenoid (code M, O)	0.36	0.65	0.94
• 5/2-way valve, double solenoid (code J, D)	0.38	0.61	0.97
• 2x 3/2-way valve (code N, K, H, P, Q, R)	0.42	0.74	0.97
Blanking plate	0.08	0.16	0.15

1) With thin metal seal, printed circuit board

2) With thin metal seal and electrical manifold module

3) With screws

4) With thin metal seal, electrical manifold module, inscription label holder, 4 screws

Dimensional Drawings

Valve Manifolds Type 44 VTSA – Inch Series

Dimensions¹⁾

Download CAD Data → www.festo.com/us/cad

Individual subbase with cable manifolds, width 0.71 in

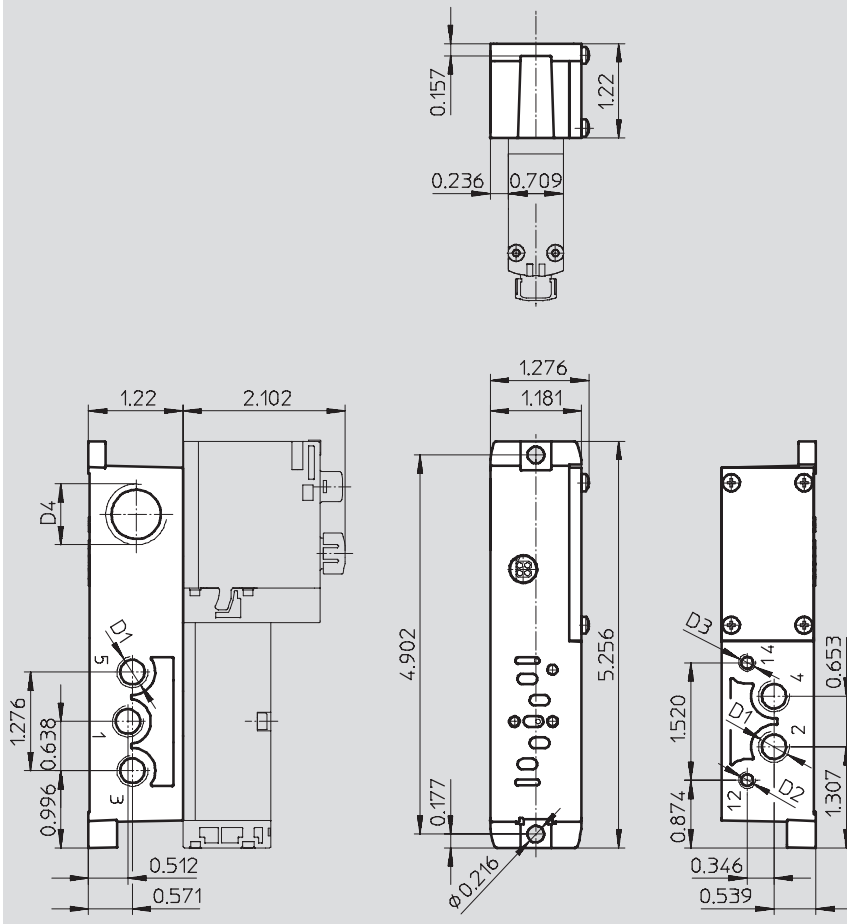

Type	D1	D2	D3	D4
External pilot air supply, cable manifolds				
VABS-S4-2S-N18-K2	1/8 NPT	10-32 UNF-2B	10-32 UNF-2B	1/2 NPT
Internal pilot air supply, cable manifolds				
VABS-S4-2S-N18-B-K2	1/8 NPT	10-32 UNF-2B	–	1/2 NPT

1) Dimensions are in inches, unless otherwise noted.

Dimensional Drawings

Valve Manifolds Type 44 VTSA – Inch Series

Dimensions¹⁾

Download CAD Data → www.festo.com/us/cad

Individual subbase with cable manifolds, width 1.02 in

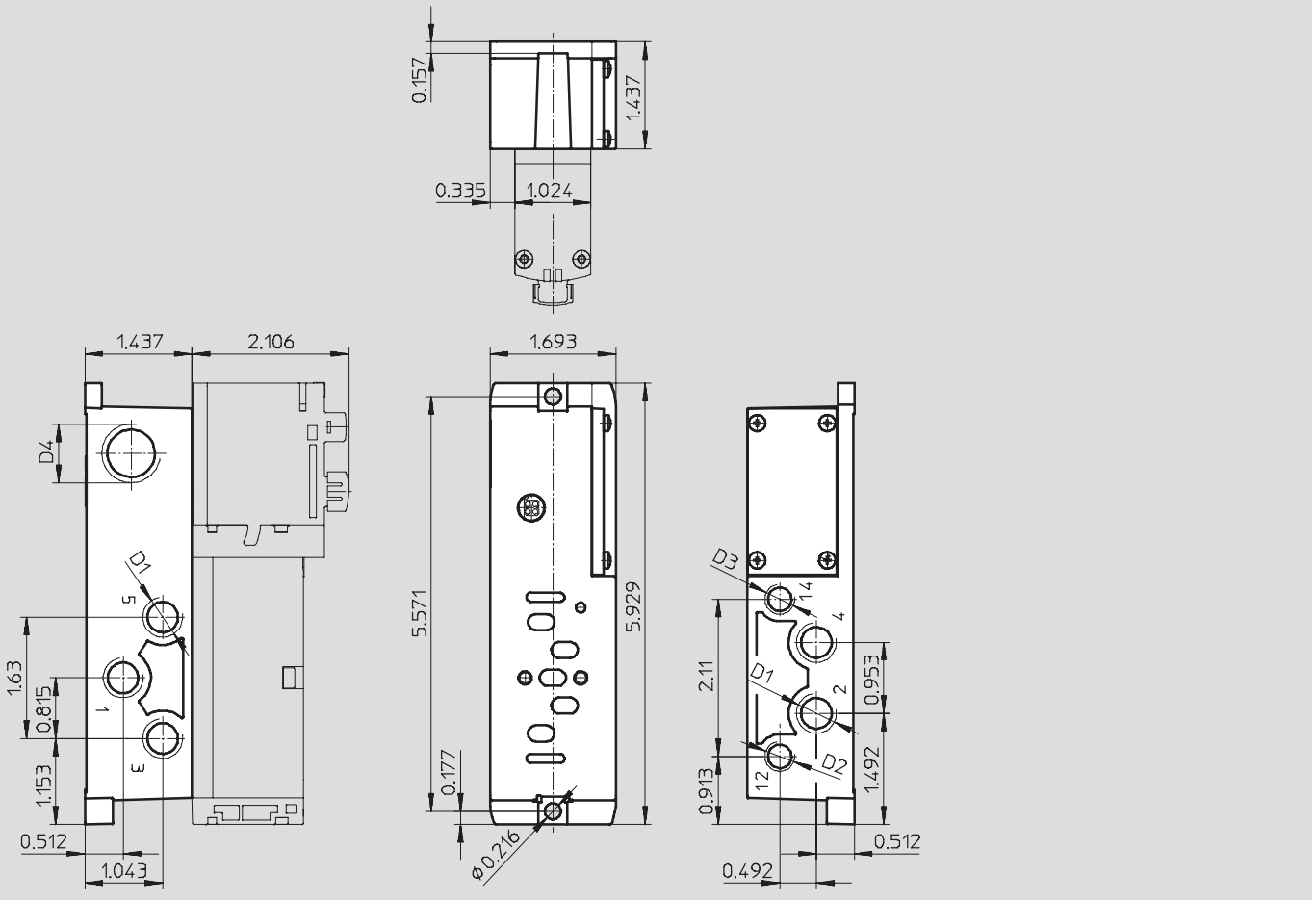

Type	D1	D2	D3	D4
External pilot air supply, cable manifolds				
VABS-S4-1S-N14-K2	¼ NPT	⅛ NPT	⅛ NPT	½ NPT
Internal pilot air supply, cable manifolds				
VABS-S4-1S-N14-B-K2	¼ NPT	⅛ NPT	-	½ NPT

1) Dimensions are in inches, unless otherwise noted.

Dimensional Drawings

Valve Manifolds Type 44 VTSA – Inch Series

Dimensions¹⁾

Download CAD Data → www.festo.com/us/cad

Individual subbase with spring-loaded manifold (C1) or for self-assembly (K1), width 1.65 in

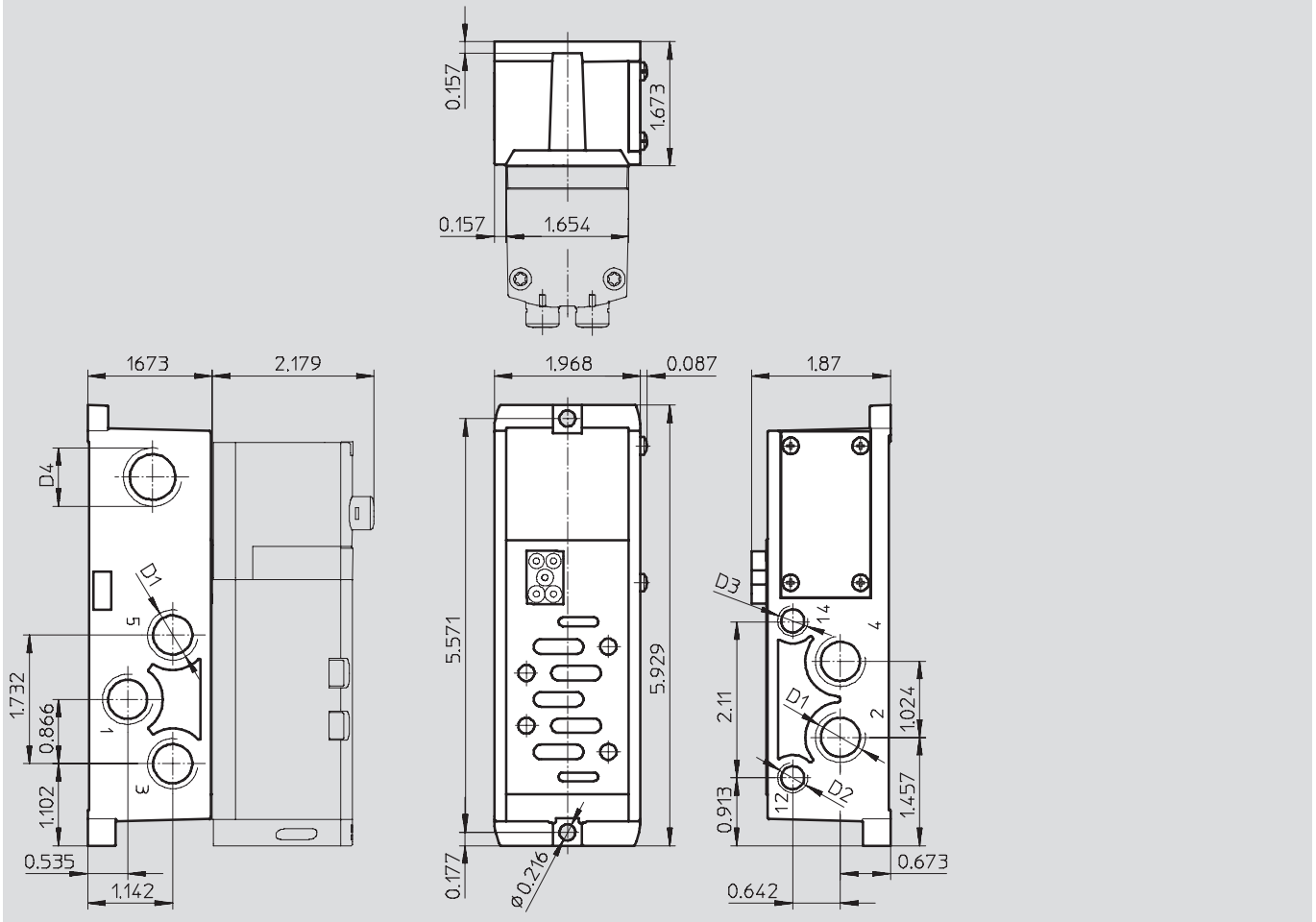

Type	D1	D2	D3	D4
External pilot air supply				
VABS-S2-1S-N38-K1(C1)	3/8 NPT	1/8 NPT	1/8 NPT	1/2 NPT
Internal pilot air supply				
VABS-S2-1S-N14-B-K1(C1)	3/8 NPT	1/8 NPT	-	1/2 NPT

1) Dimensions are in inches, unless otherwise noted.

Dimensional Drawings

Valve Manifolds Type 44 VTSA – Inch Series



Dimensions¹⁾

Download CAD Data → www.festo.com/us/cad

Valve Manifold with individual electrical connection

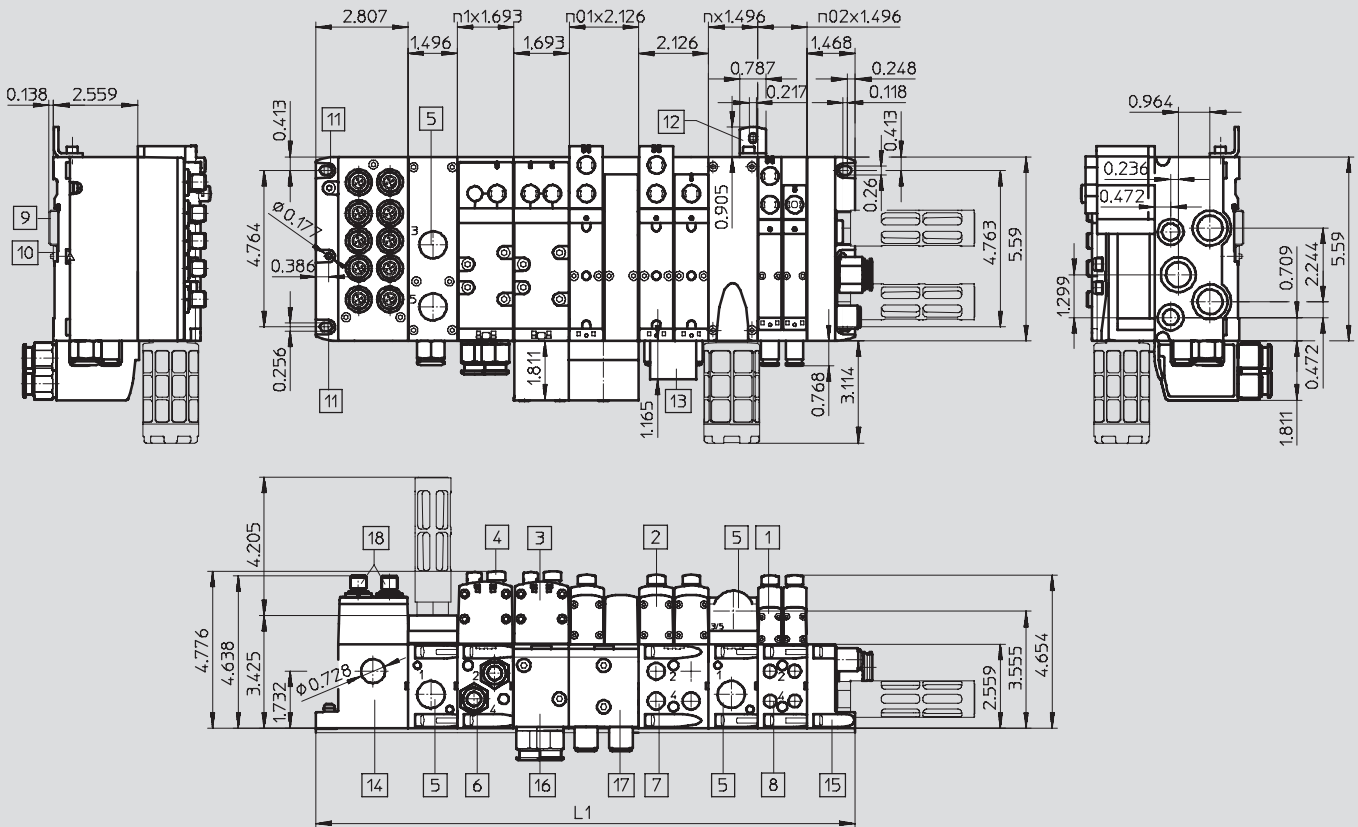

- | | | | |
|-----------------------------|--------------------------------|---|---|
| 1 Solenoid valve 0.71 in | 7 Threaded connection ¼ NPT | 13 Inscription label holder | n02 Number of manifold subbases 0.71 in |
| 2 Solenoid valve 1.02 in | 8 Threaded connection ⅛ NPT | 14 Individual connection | n01 Number of manifold subbases 1.02 in |
| 3 Solenoid valve 1.65 in | 9 DIN H-rail | 15 End plate | n1 Number of manifold subbases 1.65 in |
| 4 Cover cap/manual override | 10 DIN H-rail mounting kit | 16 90° connection plate width 1.65 in, G¾ | n Number of supply plates (only with end plate with pilot air selector) |
| 5 Threaded connection ½ NPT | 11 Mounting hole | 17 90° connection plate width 0.71 in, G¾ | |
| 6 Threaded connection ⅜ NPT | 12 Additional mounting bracket | 17 90° connection plate width 1.02 in, G¾ | |
| | | 18 M12 plug, 5-pin (6-way or 10-way) | |

Width	L1
0.71 in	$2.807 + n02 \times 1.496 + n \times 1.496 + 1.468$
1.02 in	$2.807 + n01 \times 2.126 + n \times 1.496 + 1.468$
1.65 in	$2.807 + n1 \times 1.693 + n \times 1.496 + 1.468$
Mixture of 0.71, 1.02 and 1.65 in	$2.807 + n02 \times 1.496 + n01 \times 2.126 + n1 \times 1.693 + n \times 1.496 + 1.468$

1) Dimensions are in inches, unless otherwise noted.

Dimensional Drawings

Valve Manifolds Type 44 VTSA – Inch Series

Dimensions¹⁾

Download CAD Data → www.festo.com/us/cad

Valve manifold with multi-pin plug connection

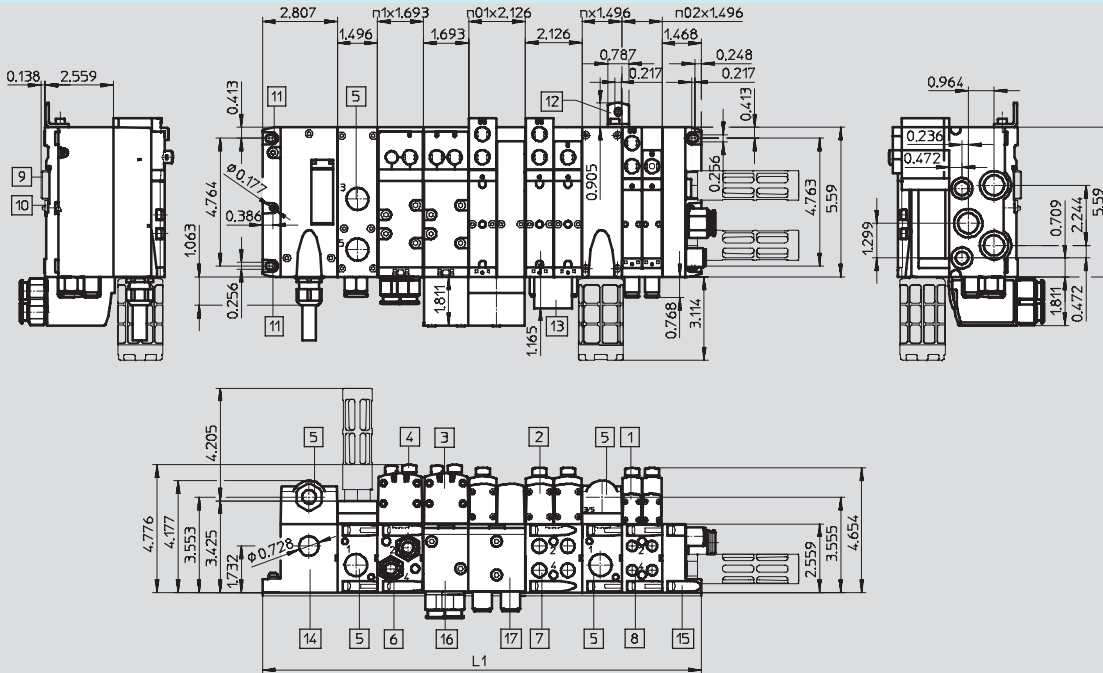

- | | | | |
|-----------------------------|-------------------------------|---|---|
| 1 Solenoid valve 0.71 in | 5 Threaded connection 1/2 NPT | 11 Mounting hole | n02 Number of manifold subbases 0.71 in |
| 2 Solenoid valve 1.02 in | 6 Threaded connection 3/8 NPT | 12 Additional mounting bracket | n01 Number of manifold subbases 1.02 in |
| 3 Solenoid valve 1.65 in | 7 Threaded connection 1/4 NPT | 13 Inscription label holder | n1 Number of manifold subbases 1.65 in |
| 4 Cover cap/manual override | 8 Threaded connection 1/8 NPT | 14 Multi-pin plug connection | n Number of supply plates |
| | 9 DIN H-rail | 15 End plate | |
| | 10 DIN H-rail mounting kit | 16 90° connection plate width 1.65 in, G3/8 | |
| | | 17 90° connection plate width 0.71 in, G3/8 | |
| | | | |
| | | | |
| | | | |
| | | | |

Width	L1
0.71 in	$2.807 + n02 \times 1.496 + n \times 1.496 + 1.468$
1.02 in	$2.807 + n01 \times 2.126 + n \times 1.496 + 1.468$
1.65 in	$2.807 + n1 \times 1.693 + n \times 1.496 + 1.468$
Mixture of 0.71, 1.02 and 1.65 in	$2.807 + n02 \times 1.496 + n01 \times 2.126 + n1 \times 1.693 + n \times 1.496 + 1.468$

Supply plate with silencer

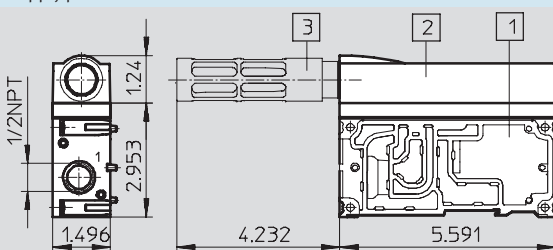

- | |
|------------------------|
| 1 Supply plate |
| 2 Exhaust port cover |
| 3 Silencer U-1/2-B-NPT |

1) Dimensions are in inches, unless otherwise noted.

Dimensional Drawings

Valve Manifolds Type 44 VTSA – Inch Series

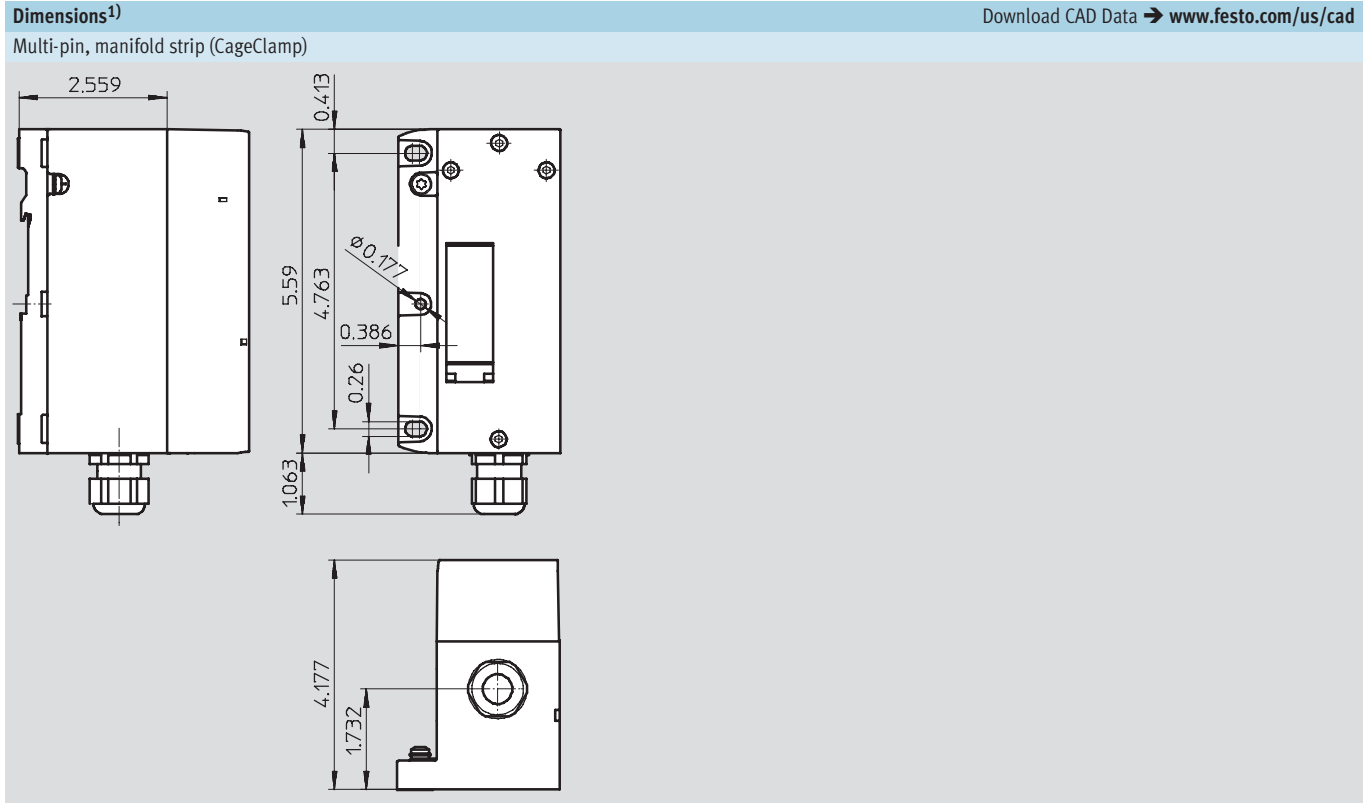

1) Dimensions are in inches, unless otherwise noted.

Dimensional Drawings

Valve Manifolds Type 44 VTSA – Inch Series

Dimensions¹⁾

Download CAD Data → www.festo.com/us/cad

Valve manifold with fieldbus connection

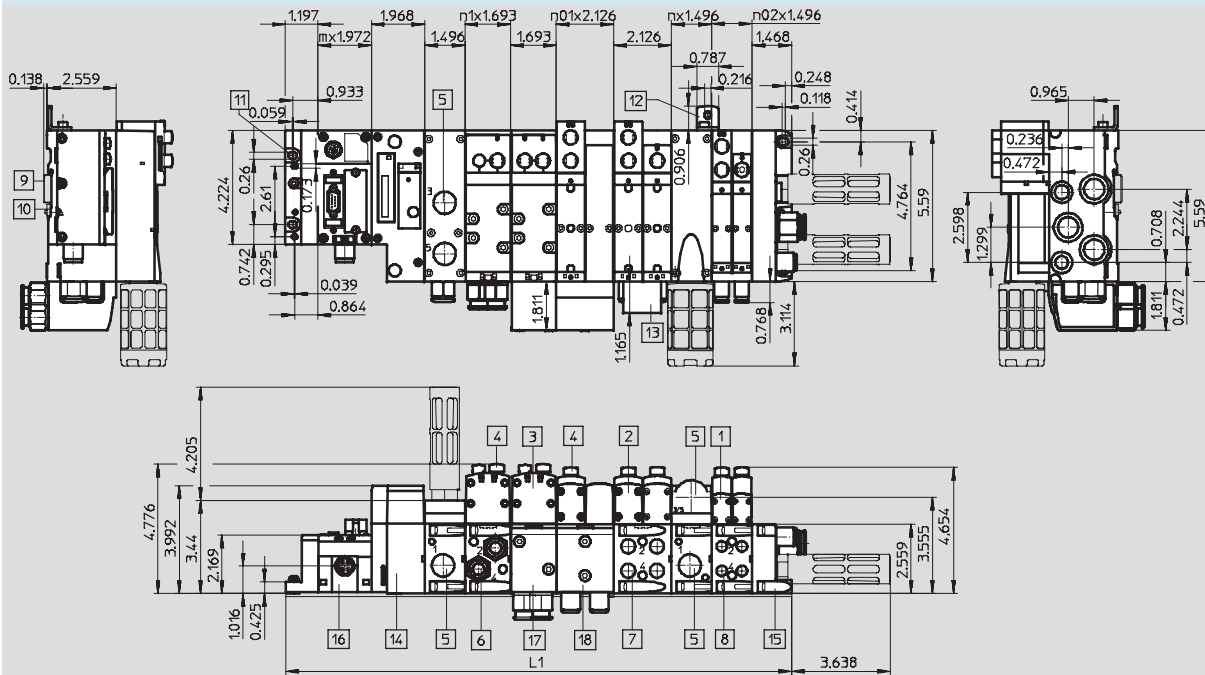

- | | | | |
|-------------------------------|--------------------------------|---|---|
| 1 Solenoid valve 0.71 in | 7 Threaded connection 1/4 NPT | 14 Pneumatic interface CPX | n02 Number of manifold subbases 0.71 in |
| 2 Solenoid valve 1.02 in | 8 Threaded connection 1/8 NPT | 15 End plate | n01 Number of manifold subbases 1.02 in |
| 3 Solenoid valve 1.65 in | 9 DIN H-rail | 16 CPX module/fieldbus node | n1 Number of manifold subbases 1.65 in |
| 4 Cover cap/manual override | 10 DIN H-rail mounting kit | 17 90° connection plate width 1.65 in, G3/8 | n Number of supply plates (only with end plate with pilot air selector) |
| 5 Threaded connection 1/2 NPT | 11 Mounting hole | 18 90° connection plate width 0.71 in, G3/8 | m Number of CPX modules |
| 6 Threaded connection 3/8 NPT | 12 Additional mounting bracket | width 1.02 in, G1/4 | |
| | 13 Inscription label holder | | |

Width	L1
0.71 in	$1.197 + m \times 1.972 + 1.968 + n02 \times 1.496 + n \times 1.496 + 1.468$
1.02 in	$1.197 + m \times 1.972 + 1.968 + n01 \times 2.126 + n \times 1.496 + 1.468$
1.65 in	$1.197 + m \times 1.972 + 1.968 + n1 \times 1.693 + n \times 1.496 + 1.468$
Mixture of 0.71, 1.02 and 1.65 in	$1.197 + m \times 1.972 + 1.968 + n02 \times 1.496 + n01 \times 2.126 + n1 \times 1.693 + n \times 1.496 + 1.468$

Supply plate with silencer

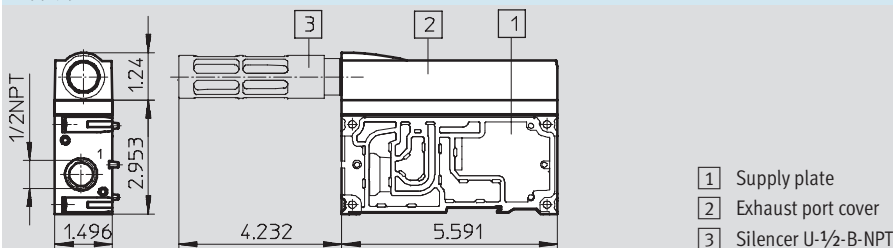

- | |
|------------------------|
| 1 Supply plate |
| 2 Exhaust port cover |
| 3 Silencer U-1/2-B-NPT |

1) Dimensions are in inches, unless otherwise noted.

Dimensional Drawings

Valve Manifolds Type 44 VTSA – Inch Series

Dimensions¹⁾ Download CAD Data → www.festo.com/us/cad

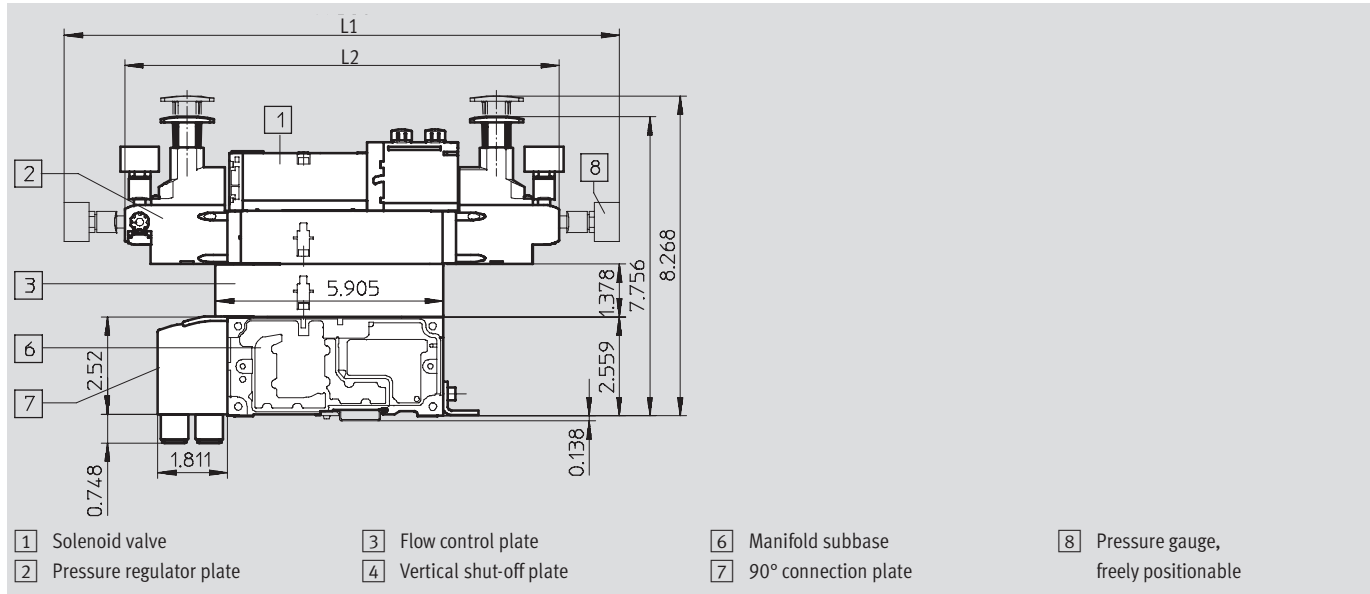
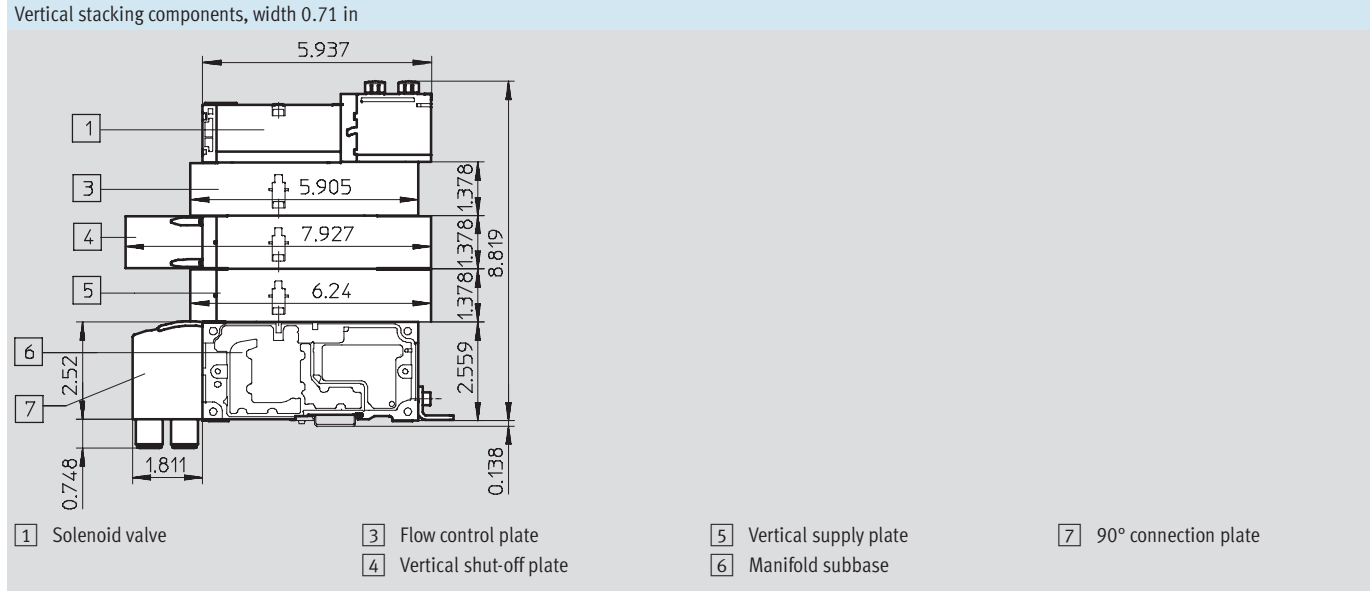

Width	L1	L2
0.71 in	13.71	10.58
1.02 in	14.40	11.26

1) Dimensions are in inches, unless otherwise noted.

Dimensional Drawings

Valve Manifolds Type 44 VTSA – Inch Series

Dimensions¹⁾ Download CAD Data → www.festo.com/us/cad

Vertical stacking components

- 1 Solenoid valve
- 2 Pressure regulator plate
- 3 Flow control plate
- 6 Manifold subbase
- 7 90° connection plate
- 8 Pressure gauge, freely positionable
- 9 Standard rotary knob
- 10 Lockable rotary knob

Width	L1	L2
0.71 in	13.71	10.58
1.02 in	14.40	11.26
1.65 in	16.15	12.27

1) Dimensions are in inches, unless otherwise noted.

Dimensional Drawings

Valve Manifolds Type 44 VTSA – Inch Series

Dimensions¹⁾

Download CAD Data → www.festo.com/us/cad

Right-hand end plate

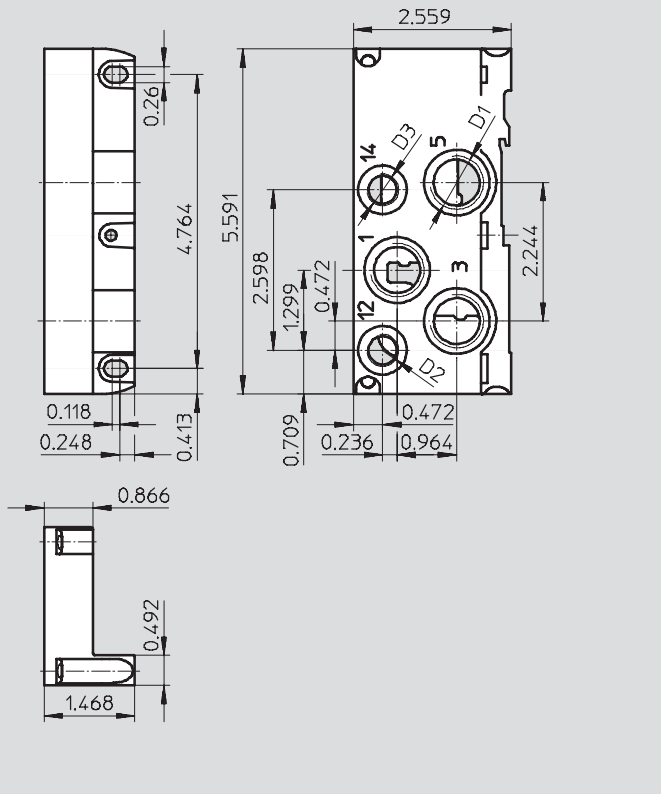

Right-hand end plate with pilot air selector

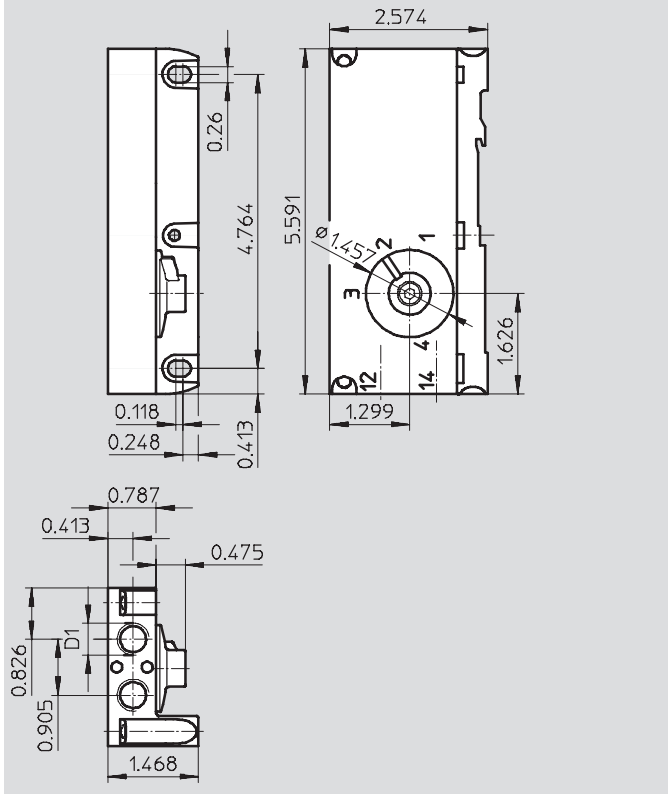

Type	D1	D2	D3
VABE-S6-1R-N12	1/2 NPT	1/4 NPT	1/4 NPT
VABE-S6-1RZ-N12			

Type	D1
VABE-S6-1RZ-N-B1	1/4 NPT

1) Dimensions are in inches, unless otherwise noted.

Dimensional Drawings

Valve Manifolds Type 45 VTSA-F – Inch Series

Dimensions¹⁾

Download CAD Data → www.festo.com/us/cad

Valve manifold with individual electrical connection

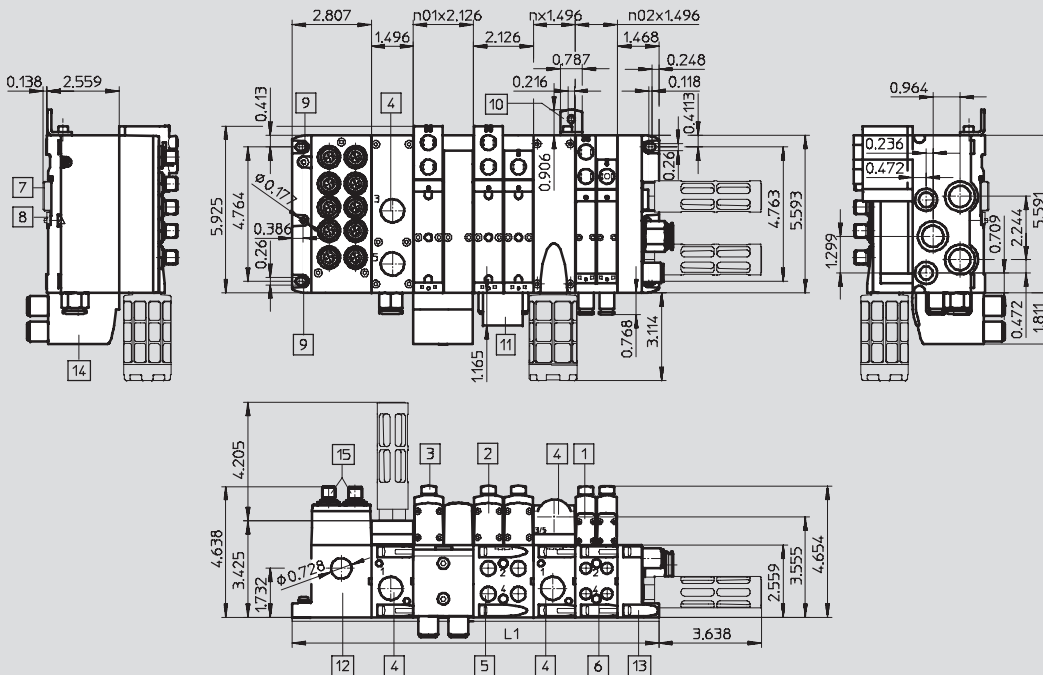

- | | | | |
|-----------------------------|-------------------------------|--------------------------------------|---|
| 1 Solenoid valve 0.71 in | 4 Threaded connection 1/2 NPT | 10 Additional mounting bracket | n02 Number of manifold subbases 0.71 in |
| 2 Solenoid valve 1.02 in | 5 Threaded connection 1/4 NPT | 11 Inscription label holder | n01 Number of manifold subbases 1.02 in |
| 3 Cover cap/manual override | 6 Threaded connection 1/8 NPT | 12 Individual connection | n Number of supply plates |
| | 7 DIN H-rail | 13 End plate | |
| | 8 DIN H-rail mounting kit | 14 90° connection plate | |
| | 9 Mounting hole | 15 M12 plug, 5-pin (6-way or 10-way) | |

Width	L1
0.71 in	$2.807 + n02 \times 1.496 + n \times 1.496 + 1.468$
1.02 in	$2.807 + n01 \times 2.126 + n \times 1.496 + 1.468$
Mixture of 0.71 and 1.02 in	$2.807 + n02 \times 1.496 + n01 \times 2.126 + n \times 1.496 + 1.468$

1) Dimensions are in inches, unless otherwise noted.

Dimensional Drawings

Valve Manifolds Type 45 VTSA-F – Inch Series



Dimensions¹⁾

Download CAD Data → www.festo.com/us/cad

Valve Manifold with multi-pin plug connection

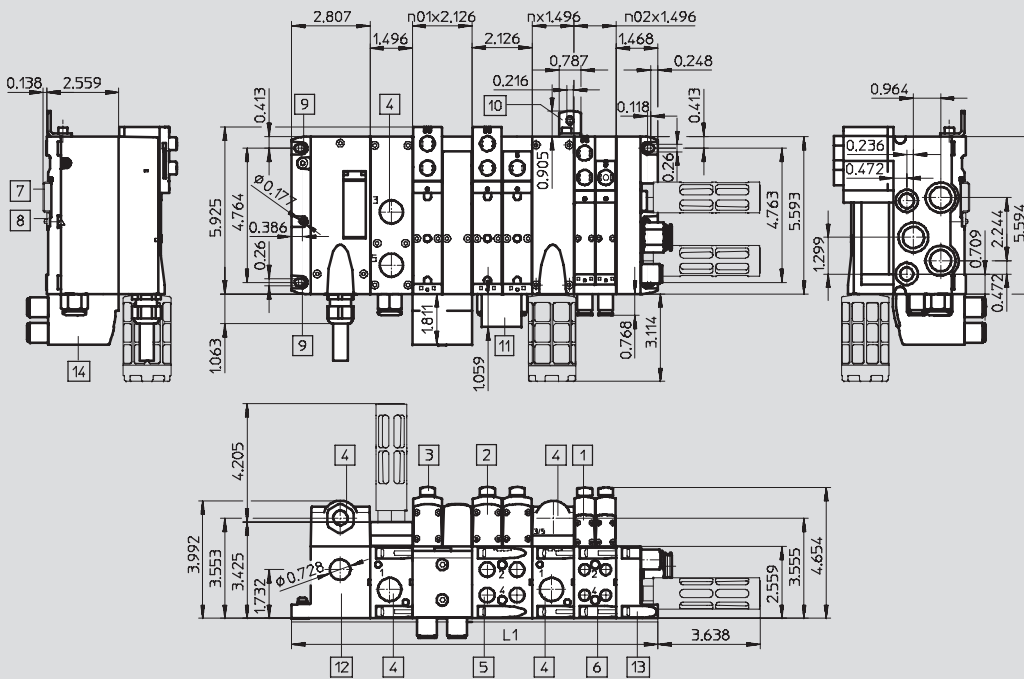

- | | | | |
|-----------------------------|-------------------------------|--------------------------------|---|
| 1 Solenoid valve 0.71 in | 4 Threaded connection 1/2 NPT | 8 DIN H-rail mounting kit | n02 Number of manifold subbases 0.71 in |
| 2 Solenoid valve 1.02 in | 5 Threaded connection 1/4 NPT | 9 Mounting hole | n01 Number of manifold subbases 1.02 in |
| 3 Cover cap/manual override | 6 Threaded connection 1/8 NPT | 10 Additional mounting bracket | n Number of supply plates |
| | 7 DIN H-rail | 11 Inscription label holder | |
| | | 12 Multi-pin plug connection | |
| | | 13 End plate | |
| | | 14 90° connection plate | |

Width	L1
0.71 in	$2.807 + n02 \times 1.496 + n \times 1.496 + 1.468$
1.02 in	$2.807 + n01 \times 2.126 + n \times 1.496 + 1.468$
Mixture of 0.71 and 1.02 in	$2.807 + n02 \times 1.496 + n01 \times 2.126 + n \times 1.496 + 1.468$

Supply plate with silencer

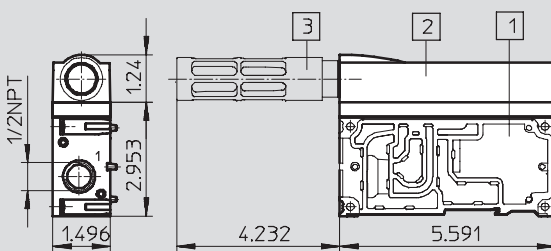

- | |
|------------------------|
| 1 Supply plate |
| 2 Exhaust port cover |
| 3 Silencer U-1/2-B-NPT |

1) Dimensions are in inches, unless otherwise noted.

Dimensional Drawings

Valve Manifolds Type 45 VTSA-F – Inch Series

Dimensions¹⁾ Download CAD Data → www.festo.com/us/cad

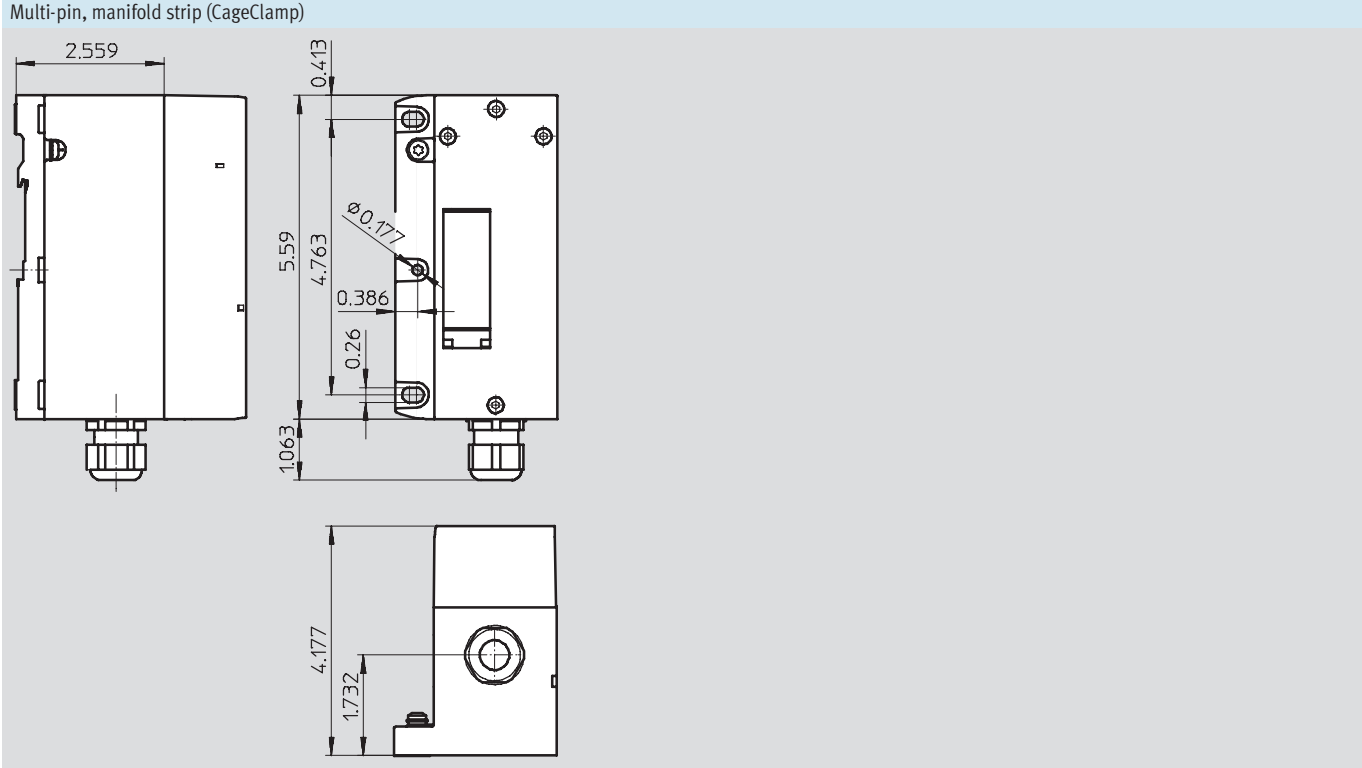

1) Dimensions are in inches, unless otherwise noted.

Dimensional Drawings

Valve Manifolds Type 45 VTSA-F – Inch Series



Dimensions¹⁾

Download CAD Data → www.festo.com/us/cad

Valve manifold with fieldbus connection

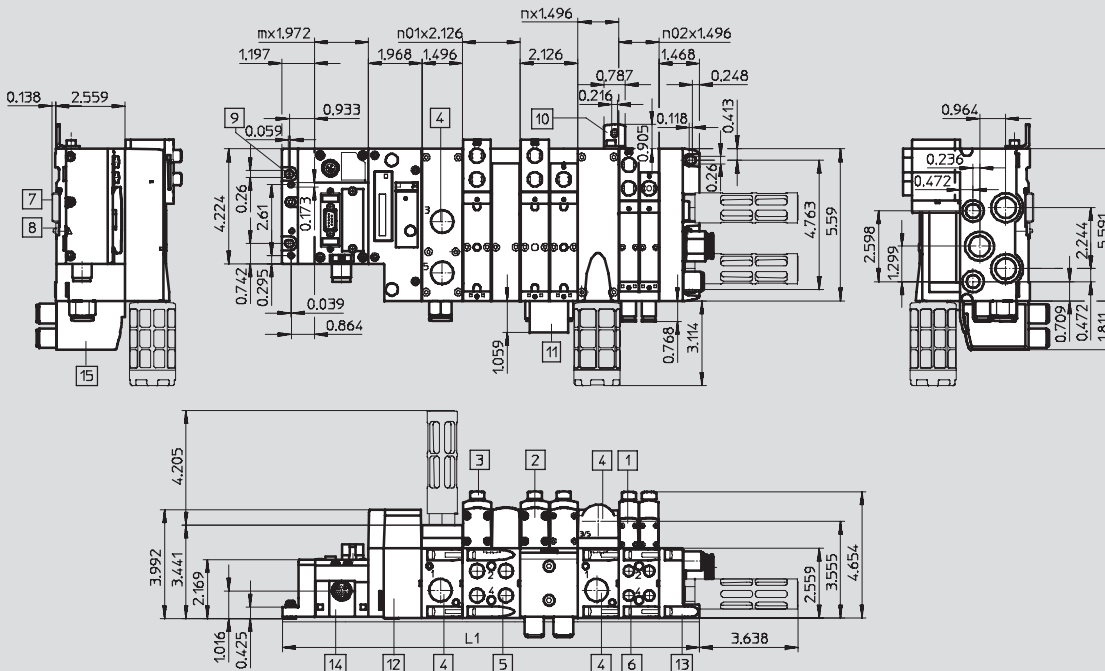

- | | | | |
|-----------------------------|-------------------------------|--------------------------------|---|
| 1 Solenoid valve 0.71 in | 4 Threaded connection 1/2 NPT | 10 Additional mounting bracket | n02 Number of manifold subbases 0.71 in |
| 2 Solenoid valve 1.02 in | 5 Threaded connection 1/4 NPT | 11 Inscription label holder | n01 Number of manifold subbases 1.02 in |
| 3 Cover cap/manual override | 6 Threaded connection 1/8 NPT | 12 Pneumatic interface CPX | n Number of supply plates |
| 7 DIN H-rail | 8 DIN H-rail mounting kit | 13 End plate | m Number of CPX modules |
| 9 Mounting hole | | 14 CPX module/fieldbus node | |
| | | 15 90° connection plate | |
| | | | width 0.71 in, G1/8 |
| | | | width 1.02 in, G1/4 |

Width	L1
0.71 in	$1.197 + m \times 1.972 + 1.968 + n02 \times 1.496 + n \times 1.496 + 1.468$
1.02 in	$1.197 + m \times 1.972 + 1.968 + n01 \times 2.126 + n \times 1.496 + 1.468$
Mixture of 0.71 and 1.02 in	$1.197 + m \times 1.972 + 1.968 + n02 \times 1.496 + n01 \times 2.126 + n \times 1.496 + 1.468$

Supply plate with silencer

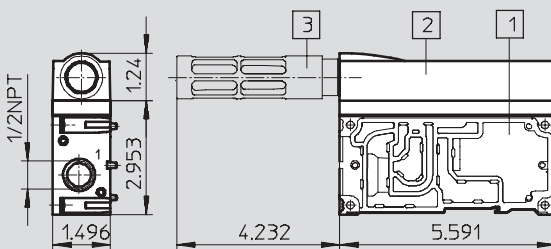

- | |
|------------------------|
| 1 Supply plate |
| 2 Exhaust port cover |
| 3 Silencer U-1/2-B-NPT |

1) Dimensions are in inches, unless otherwise noted.

Dimensional Drawings

Valve Manifolds Type 45 VTSA-F – Inch Series

Dimensions¹⁾ Download CAD Data → www.festo.com/us/cad

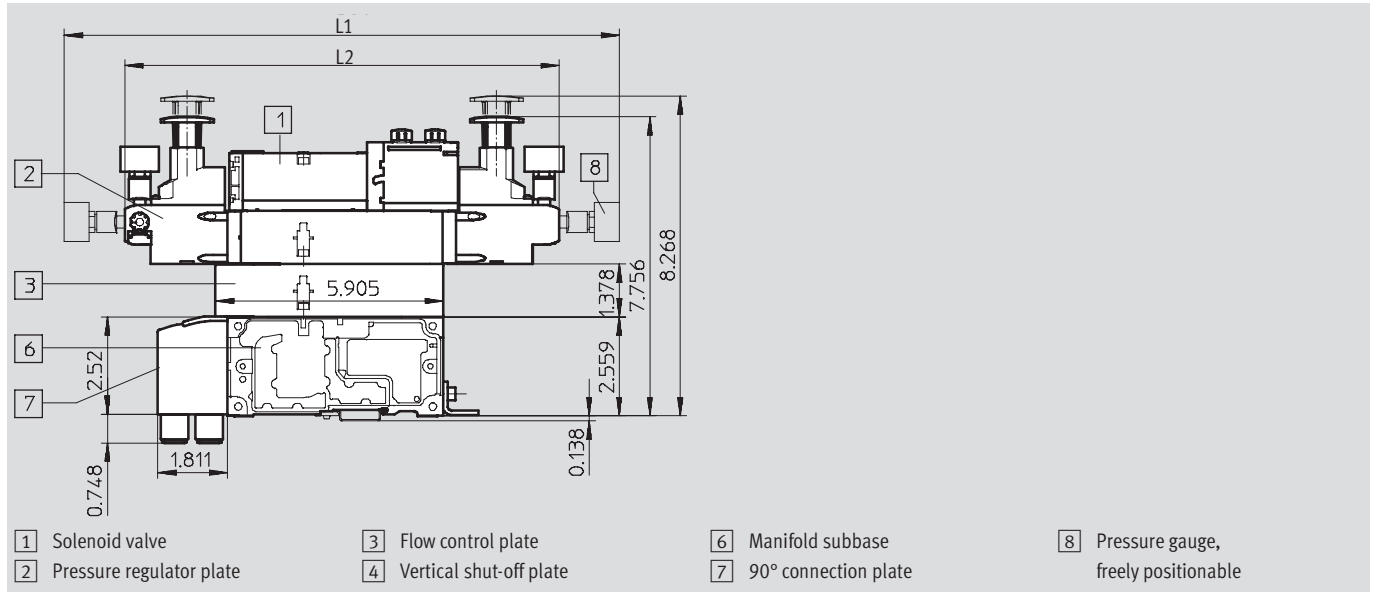
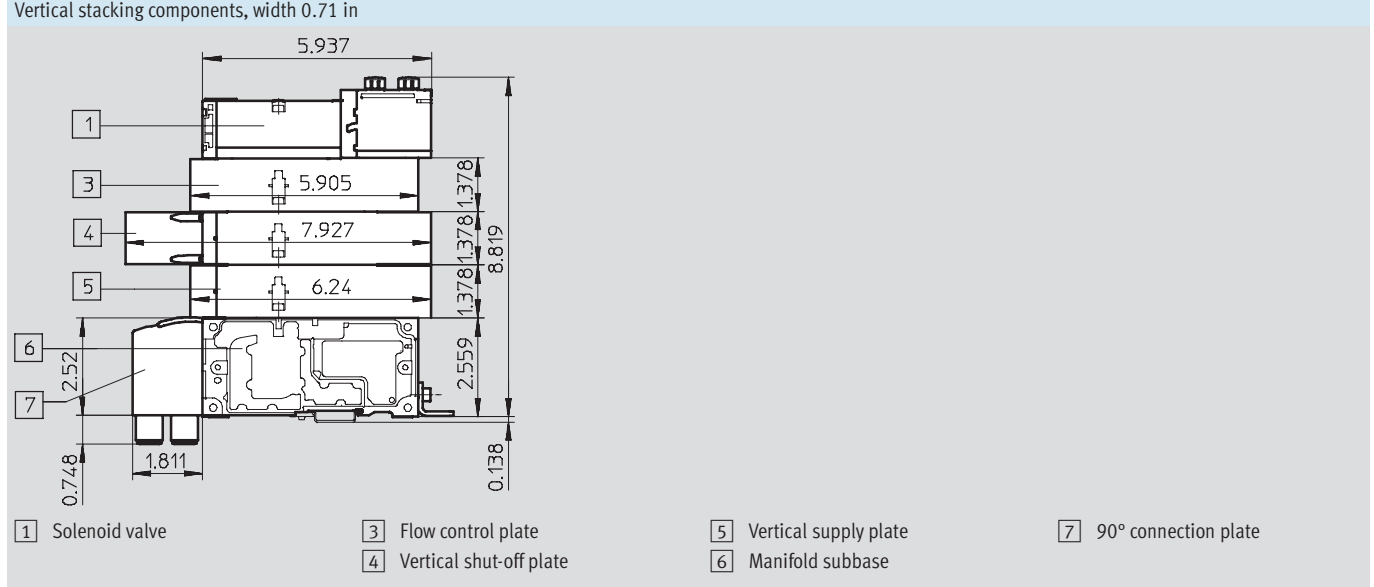

Width	L1	L2
0.71 in	13.71	10.58
1.02 in	14.40	11.26

1) Dimensions are in inches, unless otherwise noted.

Dimensional Drawings

Valve Manifolds Type 45 VTSA-F – Inch Series



Dimensions¹⁾

Download CAD Data → www.festo.com/us/cad

Right-hand end plate

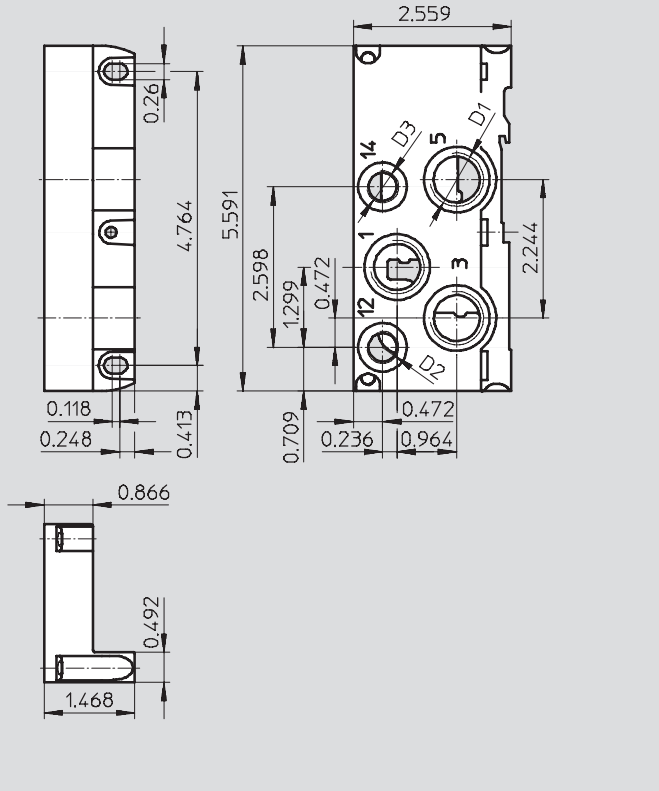

Right-hand end plate with pilot air selector

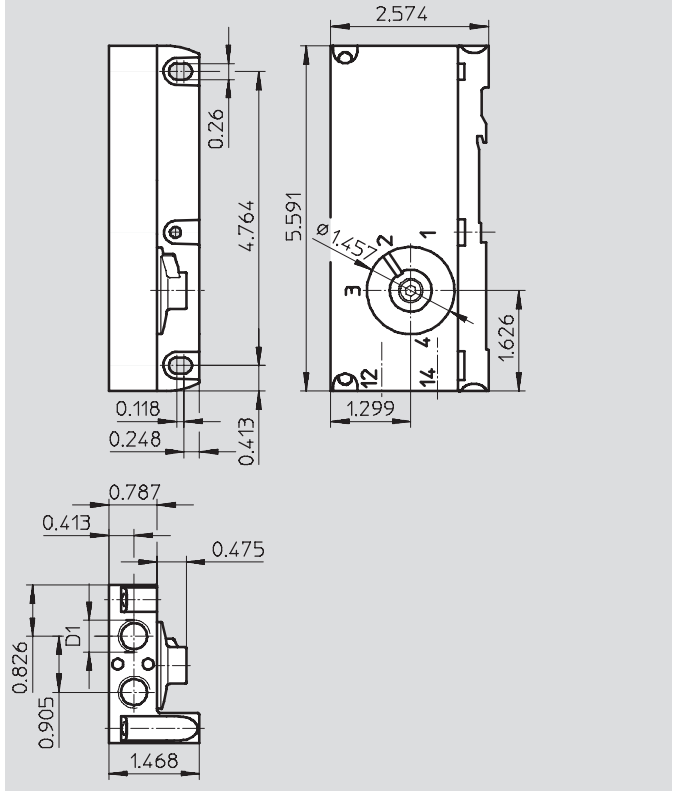

Type	D1	D2	D3
VABE-S6-1R-N12	1/2 NPT	1/4 NPT	1/4 NPT
VABE-S6-1RZ-N12			

Type	D1
VABE-S6-1RZ-N-B1	1/4 NPT

1) Dimensions are in inches, unless otherwise noted.

Online Product Configurator

Valve Manifolds Type 44 VTSA, Type 45 VTSA-F – Inch Series



Configuring VTSA Valve Manifolds

Available via our online catalog at www.festo.com/catalog/vtsa

A product configurator is available to help you configure a VTSA valve manifold that best fits your needs.

The valve manifolds are fully assembled according to your order specifications and are individually tested. This reduces the amount of assembly and installation time required to a minimum.

Valve terminals are ordered using an order code.

Ordering data for type 44

→ 168

Ordering data for type 45

→ 178

Ordering data for CPX

→ www.festo.com/catalog/cpx

The illustration provides an example of a valve manifold configuration.

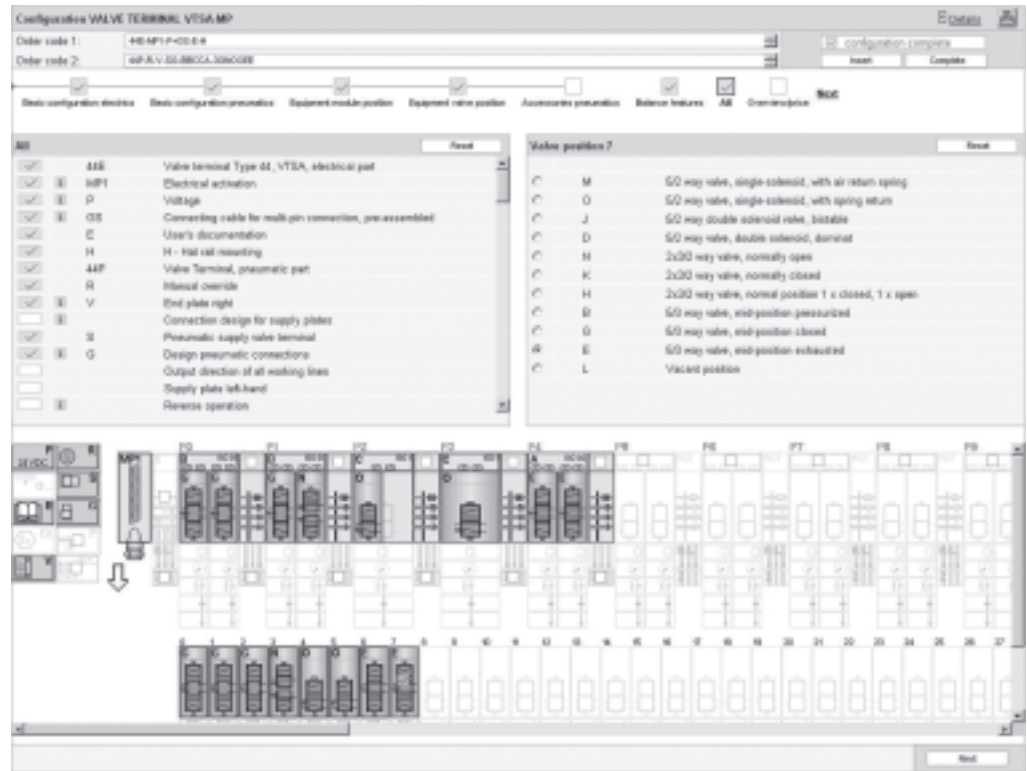

The following steps give a brief explanation of how to use the on-line Festo product configurator to determine an order code

From the Festo Industrial Automation home page www.festo.com/usa select the “Catalog” link from the “Products” menu at the top of the page; this will bring you directly to the home page for the Pneumatic Catalog.

From this location you may now use the search box, located above the Product Tree on the left hand side of the page, to perform a text based search for your product. Valid search criteria are “Part No.’s” (e.g. 539215, 547963, etc.), “Type” (e.g. VTSA, Type 44/45), or “Article Type” (e.g. valve manifold).

You may also visually navigate the catalog by using the product tree on the left or the product images off to the right.

Once you’ve located the style of VTSA (type 44 or 45, NPT or ISO, etc.) you want, click on the blue shopping basket icon (this does not initiate an order). Confirm the quantity required in the pop-up window and click Ok. You must now view your shopping basket to configure your manifold; click on the “Basket” link on the far-right side of the page and then on the configuration symbol. You can then configure the valve terminal step by step (from the top down) according to your requirements.

If you already have a complete order code, you may easily input it using the “Insert” button (upper right). The first order code (beginning with 44E or 45E) will specify your electrical configuration and options. The second part of the order code (beginning with 44P or 45P) will specify your pneumatic configuration and options.

As you make selections the product configurator will assist you by showing you various indicators along the way. Incompatible selections are indicated by a red box with an X in it. Incomplete “required” selections are indicated by a light green box. Incomplete “optional” selections are indicated by an empty box. Completed selections are indicated by a light blue box with a check mark in it.

Once you have selected all required components, look for the “Configuration Complete” indicator in the upper-right corner of the page. Press the “Complete” button to add the configured manifold to your basket for on-line order. On-line order is not required; you may also copy down your order code for future reference or phone/fax order.

Ordering Data – Configurable Products

Valve Manifolds Type 44 VTSA, NPT Thread for Multi-pin Plug – Electrical Part

M Mandatory Data				O Options		
Module No.	Valve manifold, electrical part	Electrical connection	Voltage	Connecting cable for multi-pin plug connection	User's manual	DIN H-rail mounting
539216	44E	T, MP1, MP2, MP3	P, Q	GA, GB, GC, GD, GE, GF, GG, GH, GI, GK, GL, GM, GN, GO, GP, GQ, GR, GS	D, E, F, I, S, V	H
Order example						
539216	44E	- MP1	- P	+ GE	- D	-
1	2	3	4	5	6	7

Ordering Table			Conditions	Code	Enter code	
M 1	Module No.	539216				
2	Valve manifold, electrical part	Valve manifold type 44, VTSA, electrical multi-pin plug connection/manifold box		44E		
3	Electrical connection	Multi-pin plug, CageClamp	1	-T		
		Electrical multi-pin plug connection, Sub-D (37-pin)	1	-MP1		
		Electrical multi-pin plug connection, individual connection with M12, 6-way	2	-MP2		
		Electrical multi-pin plug connection, individual connection with M12, 10-way	3	-MP3		
4	Voltage	24 V DC		-P		
		110 V AC	5	-Q		
O 5	Electrical accessories			+	+	
	Connecting cable for multi-pin plug connection, pre-assembled, supplied loose	Polyurethane				
		Connecting cable for Sub-D, 8.2 ft, 10-core, 8 solenoid coils	6	GA		
		Connecting cable for Sub-D, 16.4 ft, 10-core, 8 solenoid coils	6	GB		
		Connecting cable for Sub-D, 32.8 ft, 10-core, 8 solenoid coils	6	GC		
		Connecting cable for Sub-D, 8.2 ft, 26-core, 22 solenoid coils	6	GD		
		Connecting cable for Sub-D, 16.4 ft, 26-core, 22 solenoid coils	6	GE		
		Connecting cable for Sub-D, 32.8 ft, 26-core, 22 solenoid coils	6	GF		
		Connecting cable for Sub-D, 8.2 ft, 37-core, 32 solenoid coils	6	GG		
		Connecting cable for Sub-D, 16.4 ft, 37-core, 32 solenoid coils	6	GH		
		Connecting cable for Sub-D, 32.8 ft, 37-core, 32 solenoid coils	6	GI		
		Polyvinyl chloride				
		Connecting cable for Sub-D, 8.2 ft, 10-core, 8 solenoid coils	6	GK		
		Connecting cable for Sub-D, 16.4 ft, 10-core, 8 solenoid coils	6	GL		
		Connecting cable for Sub-D, 32.8 ft, 10-core, 8 solenoid coils	6	GM		
		Connecting cable for Sub-D, 8.2 ft, 27-core, 22 solenoid coils	6	GN		
		Connecting cable for Sub-D, 16.4 ft, 27-core, 22 solenoid coils	6	GO		
		Connecting cable for Sub-D, 32.8 ft, 27-core, 22 solenoid coils	6	GP		
		Connecting cable for Sub-D, 8.2 ft, 37-core, 32 solenoid coils	6	GQ		
		Connecting cable for Sub-D, 16.4 ft, 37-core, 32 solenoid coils	6	GR		
		Connecting cable for Sub-D, 32.8 ft, 37-core, 32 solenoid coils	6	GS		
6	User's manual	German		-D		
		English		-E		
		French		-F		
		Italian		-I		
		Spanish		-S		
		Swedish		-V		
7	DIN H-rail mounting	1		-H		

- 1 T, MP1 Max. 32 addresses can be selected
- 2 MP2 Max. 12 addresses can be selected
- 3 MP3 Max. 20 addresses can be selected

- 5 Q Only with electrical connection (3) T (multi-pin plug, CageClamp)
- 6 G... Not with electrical connection (3) T, MP2, MP3 and MP4

Ordering Data – Configurable Products

Valve Manifolds Type 44 VTSA, NPT Thread for Multi-pin Plug – Pneumatic Part

M Mandatory Data				O Options					
Module No.	Valve manifold, pneumatic part	Manual override	Right-hand end plate	Port configuration for supply plates	Pneumatic supply to valve Manifold	Configuration of all pneumatic connections	Outgoing direction of all working lines	Left-hand supply plate	Reverse operation
539216	44PN	N, R, V	V, X, Y, U, Z, W	K, L	S, V	M, N, G	P	X	Z
Order example	44PN	- R	- V	- K	S	M	P	X	
1	2	3	4	5	6	7	8	9	10

Ordering Table		Width	0.71 in	1.02 in	1.65 in – size 1	Conditions	Code	Enter code
M	1	Module No.	539216	539216	539216			
	2	Valve manifold, pneumatic part	Valve manifold type 44, VTSA, modular subbase valves to ISO 15407-2, pneumatic connections with NPT thread				44PN	
	3	Manual override	Pushing (non-detenting)				-N	
			Pushing/detenting				-R	
			Covered				-V	
	4	Right-hand end plate	Right-hand end plate, with supply air/exhaust air, internal pilot air supply				-V	
			Right-hand end plate with supply air/exhaust air, external pilot air supply				-X	
			End plate with pilot air selector, internal pilot air supply			1	-Y	
			End plate with pilot air selector, internal pilot air supply, ducted pilot exhaust air			1	-U	
			End plate with pilot air selector, external pilot air supply			1	-Z	
			End plate with pilot air selector, external pilot air supply, ducted pilot exhaust air			1	-W	
O	5	Port configuration for supply plates	Normal operation: Supply port 1, exhaust port 3/5 separated			2	-K	
			Reverse operation: Exhaust port 1, supply port 3/5 separated					
			Normal operation: Supply port 1, exhaust port 3/5 common			2	-L	
			Reverse operation: Exhaust port 1, supply port 3/5 common					
	6	Pneumatic valve manifold supply (standard: threaded connection)	Silencer and QS push-in fittings				S	
			QS push-in fittings				V	
	7	Configuration of all pneumatic connections	QS push-in fittings, large			3	M	
			QS push-in fittings, small			3	N	
			QS push-in fittings, large and small mixed			3	G	
	8	Outgoing direction of all working lines (standard outlet at front)	90° connection plate, outlet at bottom				P	
	9	Left-hand supply plate	Left-hand supply plate in front of manifold subbase 00				X	
	10	Reverse operation	Reverse operation as of valve position 00			4	Z	

- 1 **Y, U, Z, W** At least one left-hand supply plate (9) X or one compressed air supply/duct separation (12) U, SU, TU, RU, USU, UTU or URU must be selected
- 2 **K, L** Must be selected if left-hand supply plate (9) X or one compressed air supply/duct separation (12) (S, T, R, U, SU, US, TU, UT, RU, UR, USU, UTU, URU) was selected
- 3 **M, N, G** Must be selected if pneumatic valve manifold supply (6) S or V was selected
- 4 **Z** A reversible pressure zone cannot be terminated with a right-hand end plate (4) V, Y, U (internal pilot air supply)

Ordering Data – Configurable Products



Valve Manifolds Type 44 VTSA, NPT Thread for Multi-pin Plug – Pneumatic Part

→ 0 Options →

Pneumatic manifold subbases 00 ... 15

11 Type of interlinking block: A, B, C, E, F, G, AK, BK, CK, EK, FK, GK
 12 Compressed air supply/duct separation: S, T, R, U, SU, US, TU, UT, RU, UR, USU, UTU, URU
 13 Reverse operation: Z

Module position

00	01	02	03	04	05	06	07	08	09	10	11	12	13	14	15
A	B	B	BS	B											

11 + 12 + 13

Ordering Table		Width	0.71 in	1.02 in	1.65 in – size 1	Condit ions	Code	Enter code
↓	11	Pneumatic manifold subbases				5	-	-
0		Type of interlinking block 00 ... 15	Manifold subbase	2 valve positions, 4 addresses	–		A	Enter the equipment selected in the order code
				–	2 valve positions, 4 addresses		B	
				–	–		C	
				2 valve positions, 2 addresses	–	6	E	
				–	2 valve positions, 2 addresses	6	F	
				–	–	6	G	
			Manifold subbase with QS push-in fittings, small	2 valve positions, 4 addresses	–	7	AK	
				–	2 valve positions, 4 addresses	7	BK	
				–	–	7	CK	
				2 valve positions, 2 addresses	–	8	EK	
				–	2 valve positions, 2 addresses	8	FK	
				–	–	8	GK	
				–	1 valve position, 1 address	8	GK	
	12	Compressed air supply/duct separation 00 ... 15		Duct separation 1, 3, 5		9 10	S	
				Duct separation 1		9 10	T	
				Duct separation 3, 5		9 10	R	
				Supply plate			U	
				Supply plate with duct separation 1, 3, 5 at left		9	SU	
				Supply plate with duct separation 1, 3, 5 at right		9	US	
				Supply plate with duct separation 1 at left		9	TU	
				Supply plate with duct separation 1 at right		9	UT	
				Supply plate with duct separation 3, 5 at left		9	RU	
				Supply plate with duct separation 3, 5 at right		9	UR	
				2 supply plates with duct separation 1, 3, 5 in centre			USU	
				2 supply plates with duct separation 1 in centre			UTU	
				2 supply plates with duct separation 3, 5 in centre			URU	
↓	13	Reverse operation 00 ... 15		Subsequent valve positions permitted for reverse operation		11	Z	

- 5 Manifold subbases must be fitted throughout without any gaps
- 6 E, F, G Only with valves (14) M, O and L
- 7 AK, BK, CK Only with configuration of all pneumatic connections (7) N or G
- 8 EK, FK, GK Only with configuration of all pneumatic connections (7) N or G.
Only with valves (14) M, O and L

- 9 S, T, R, SU, US, TU, UT, RU, UR No pressure-free zones may be created
- 10 S, T, R Cannot be selected on last manifold subbase
- 11 Z Only with compressed air supply/duct separation (12) S, SU, US or USU.
A reversible pressure zone cannot be terminated with a right-hand end plate (4) V, Y, U

Ordering Data – Configurable Products



Valve Manifolds Type 44 VTSA, NPT Thread for Multi-pin Plug – Pneumatic Part

→ 0 Options →

Pneumatic valve positions 00 ... 31

- 14 Valve position 00 ... 31: M, O, J, D, N, K, H, B, G, E, P, Q, R, L
- 15 Pressure regulator for position 00 ... 31: ZA, ZB, ZC, ZD, ZE, ZK, ZL, ZF, ZG, ZH, ZI, ZJ, ZM, ZN
- 16 Pressure indicator for position 00 ... 31: T, U
- 17 Flow control valve position 00 ... 31: X
- 18 Vertical pressure isolating plate for position 00 ... 31: ZT
- 19 Vertical supply plate for position 00 ... 31: ZU

Valve position		19 Vertical supply plate for position 00 ... 31: ZU																					
00	01	02	03	04	05	06	07	08	09	10	11	12	13	14	15	16	17	18	19	20	...	30	31
M	M	M	O	O	O	J	J	E	E												...		

14 + 15 + 16 + 17 + 18 + 19

Ordering Table		Width	0.71 in	1.02 in	1.65 in – size 1	Conditions	Code	Enter code
↓	14	Pneumatic valve positions 00 ... 31					-	-
	0	Valve position 00 ... 31	5/2-way valve, single solenoid with pneumatic spring return				M	Enter equipment selection for valve positions in order code
		5/2-way valve, single solenoid with spring return				O		
		5/2-way valve, double solenoid				J		
		5/2-way valve, double solenoid with dominant signal				D		
		2x 3/2-way valve, normally open			12	N		
		2x 3/2-way valve, normally closed			12	K		
		2x 3/2-way valve, 1x normally closed, 1x normally open			12	H		
		5/3-way valve, mid-position pressurised				B		
		5/3-way valve, mid-position closed				G		
		5/3-way valve, mid-position exhausted				E		
		2x 3/2-way valve, normally open, reverse operation			13	P		
		2x 3/2-way valve, normally closed, reverse operation			13	Q		
		2x 3/2-way valve, 1x normally closed, 1x normally open, reverse operation			13	R		
		Vacant position				L		
↓	15	Pressure regulator for valve position 00 ... 31	Input pressure 147 psi	Pressure regulator plate for port 1		14	ZA	
				Pressure regulator plate for port 4			ZB	
		Pressure regulator plate for port 2			ZC			
		Pressure regulator plate for port 4/2			ZD			
		Pressure regulator plate for port 4/2, reversible		15	ZE			
		Pressure regulator plate for port 4, reversible		15	ZK			
		Pressure regulator plate for port 2, reversible		15	ZL			
		Input pressure 88 psi	Pressure regulator plate for port 1		14	ZF		
		Pressure regulator plate for port 4			ZG			
		Pressure regulator plate for port 2			ZH			
		Pressure regulator plate for port 4/2			ZI			
		Pressure regulator plate for port 4/2, reversible		15	ZJ			
		Pressure regulator plate for port 4, reversible		15	ZM			
		Pressure regulator plate for port 2, reversible		15	ZN			

- 12 N, K, H Not permitted in zones with reverse operation. Not with pressure regulator (15) ZE, ZJ (reversible pressure regulator plate)
- 13 P, Q, R Only permissible in zones with reverse operation or with pressure regulator (15) ZE, ZJ (reversible pressure regulator plate). Pilot pressure required on duct 12 (ducted exhaust air not possible). Not with right-hand end plate (4) Y, Z
- 14 ZA, ZF Not permitted in zones with reverse operation
- 15 ZE, ZK, ZL, ZJ, ZM, ZN Not permitted in zones with reverse operation. Not with 2x 3/2-way valves (14) N, K, H

Ordering Data – Configurable Products



Valve Manifolds Type 44 VTSA, NPT Thread for Multi-pin Plug – Pneumatic Part

➔ 0 Options

Pneumatic accessories

U, ...B, ...T, ...N, ...V

+ 10N
20

Ordering Table						
Width	0.71 in	1.02 in	1.65 in – size 1	Conditions	Code	Enter code
↓ 0	16 Pressure indicator for valve position 00 ... 31	Pressure gauge, 147 psi		16	T	Enter equipment selection for valve positions in order code
		Pressure gauge, 88 psi		17	U	
17	Flow control valve for valve position 00 ... 31	Flow control plate		18	X	
18	Vertical isolating plate for valve position 00 ... 31	Pressure separator plate on valve assembly		19	ZT	
19	Vertical supply plate for valve position 00 ... 31	Compressed air supply on valve		18	ZU	
20	Pneumatic accessories				+	
	Mounting brackets (pack of 5)	Supplied separately		20	U	+
	Inscription label holder for valves	5 ... 50			...B	
	Inscription label holder for manifold subbases	5 ... 50			...T	
	Cover cap for manual override, pushing	10 ... 90			...N	
	Cover cap for manual override, covered	10 ... 90			...V	

- 16 T Only with pressure regulator (15) ZA, ZB, ZC, ZD, ZE
- 17 U Only with pressure regulator (15) ZF, ZG, ZH, ZI, ZJ
- 18 X, ZU Not with valves with reverse operation (14) P, Q, R

- 19 ZT Not with right-hand end plate (4) Y, Z
- 20 U Can only be selected if there are more than 9 valve positions

Ordering Data – Configurable Products

Valve Manifolds Type 44 VTSA, NPT Thread for CPX – Pneumatic Part

M Mandatory Data				O Options					
Module No.	Valve manifold, pneumatic part	Manual override	Right-hand end plate	Port configuration for supply plates	Pneumatic supply to valve manifold	Configuration of all pneumatic connections	Outgoing direction of all working lines	Left-hand supply plate	Reverse operation
539218	44PN	N, R, V	V, X, Y, U, Z, W	K, L	S, V	M, N, G	P	X	Z
Order example	44PN	- R	- V	- K	S	M	P	X	
1	2	3	4	5	6	7	8	9	10

Ordering Table		Width	0.71 in	1.02 in	1.65 in – size 1	Conditions	Code	Enter code
M	1	Module No.	539218	539218	539218			
	2	Valve manifold, pneumatic part	Valve manifold type 44, VTSA, modular subbase valves to ISO 15407-2, pneumatic connections with NPT thread				44PN	
	3	Manual override	Pushing (non-detenting)				-N	
			Pushing/detenting				-R	
			Covered				-V	
	4	Right-hand end plate	Right-hand end plate, with supply air/exhaust air, internal pilot air supply				-V	
			Right-hand end plate with supply air/exhaust air, external pilot air supply				-X	
			End plate with pilot air selector, internal pilot air supply			1	-Y	
			End plate with pilot air selector, internal pilot air supply, ducted pilot exhaust air			1	-U	
			End plate with pilot air selector, external pilot air supply			1	-Z	
			End plate with pilot air selector, external pilot air supply, ducted pilot exhaust air			1	-W	
O	5	Port configuration for supply plates	Normal operation: Supply port 1, exhaust port 3/5 separated			2	-K	
			Reverse operation: Exhaust port 1, supply port 3/5 separated					
			Normal operation: Supply port 1, exhaust port 3/5 common			2	-L	
			Reverse operation: Exhaust port 1, supply port 3/5 common					
	6	Pneumatic valve manifold supply (standard: threaded connection)	Silencer and QS push-in fittings				S	
			QS push-in fittings				V	
	7	Configuration of all pneumatic connections	QS push-in fittings, large			3	M	
			QS push-in fittings, small			3	N	
			QS push-in fittings, large and small mixed			3	G	
	8	Outgoing direction of all working lines (standard outlet at front)	90° connection plate, outlet at bottom				P	
	9	Left-hand supply plate	Left-hand supply plate in front of manifold subbase 00				X	
	10	Reverse operation	Reverse operation as of valve position 00			4	Z	

- 1 Y, U, Z, W At least one left-hand supply plate (9) X or one compressed air supply/duct separation (12) U, SU, TU, RU, USU, UTU or URU must be selected
- 2 K, L Must be selected if left-hand supply plate (9) X or one compressed air supply/duct separation (12) (S, T, R, U, SU, US, TU, UT, RU, UR, USU, UTU, URU) was selected
- 3 M, N, G Must be selected if pneumatic valve manifold supply (6) S or V was selected
- 4 Z A reversible pressure zone cannot be terminated with a right-hand end plate (4) V, Y, U (internal pilot air supply)

Ordering Data – Configurable Products

Valve Manifolds Type 44 VTSA, NPT Thread for CPX – Pneumatic Part



→ 0 Options →

Pneumatic manifold subbases 00 ... 15

11 Type of interlinking block: A, B, C, E, F, G, AK, BK, CK, EK, FK, GK
 12 Compressed air supply/duct separation: S, T, R, U, SU, US, TU, UT, RU, UR, USU, UTU, URU
 13 Reverse operation: Z

Module position

00	01	02	03	04	05	06	07	08	09	10	11	12	13	14	15
A	B	B	BS	B											

11 + 12 + 13

Ordering Table		Width	0.71 in	1.02 in	1.65 in – size 1	Condit ions	Code	Enter code
↓	11	Pneumatic manifold subbases				5	-	-
0	Type of interlinking block 00 ... 15	Manifold subbase	2 valve positions, 4 addresses	–	–		A	Enter the equipment selected in the order code
			–	2 valve positions, 4 addresses	–		B	
			–	–	1 valve position, 2 addresses		C	
			2 valve positions, 2 addresses	–	–	6	E	
			–	2 valve positions, 2 addresses	–	6	F	
		Manifold subbase with QS push-in fittings, small	2 valve positions, 4 addresses	–	–	6	G	
			–	2 valve positions, 4 addresses	–	7	AK	
			–	–	1 valve position, 2 addresses	7	BK	
			2 valve positions, 2 addresses	–	–	7	CK	
			–	2 valve positions, 2 addresses	–	8	EK	
		–	2 valve positions, 2 addresses	–	8	FK		
		–	–	1 valve position, 1 address	8	GK		
	12	Compressed air supply/duct separation 00 ... 15	Duct separation 1, 3, 5			9 10	S	
			Duct separation 1			9 10	T	
			Duct separation 3, 5			9 10	R	
			Supply plate				U	
			Supply plate with duct separation 1, 3, 5 at left			9	SU	
			Supply plate with duct separation 1, 3, 5 at right			9	US	
			Supply plate with duct separation 1 at left			9	TU	
			Supply plate with duct separation 1 at right			9	UT	
			Supply plate with duct separation 3, 5 at left			9	RU	
			Supply plate with duct separation 3, 5 at right			9	UR	
			2 supply plates with duct separation 1, 3, 5 in centre				USU	
			2 supply plates with duct separation 1 in centre				UTU	
			2 supply plates with duct separation 3, 5 in centre				URU	
↓	13	Reverse operation 00 ... 15	Subsequent valve positions permitted for reverse operation			11	Z	

- 5 Manifold subbases must be fitted throughout without any gaps
- 6 E, F, G Only with valves (14) M, O and L
- 7 AK, BK, CK Only with configuration of all pneumatic connections (?) N or G
- 8 EK, FK, GK Only with configuration of all pneumatic connections (?) N or G.
Only with valves (14) M, O and L

- 9 S, T, R, SU, US, TU, UT, RU, UR No pressure-free zones may be created
- 10 S, T, R Cannot be selected on last manifold subbase
- 11 Z Only with compressed air supply/duct separation (12) S, SU, US or USU.
A reversible pressure zone cannot be terminated with a right-hand end plate (4) V, Y, U

Ordering Data – Configurable Products

Valve Manifolds Type 44 VTSA, NPT Thread for CPX – Pneumatic Part



→ 0 Options →

Pneumatic valve positions 00 ... 31

- 14 Valve position 00 ... 31: M, O, J, D, N, K, H, B, G, E, P, Q, R, L
- 15 Pressure regulator for position 00 ... 31: ZA, ZB, ZC, ZD, ZE, ZK, ZL, ZF, ZG, ZH, ZI, ZJ, ZM, ZN
- 16 Pressure indicator for position 00 ... 31: T, U
- 17 Flow control valve position 00 ... 31: X
- 18 Vertical pressure isolating plate for position 00 ... 31: ZT
- 19 Vertical supply plate for position 00 ... 31: ZU

Valve position		19 Vertical supply plate for position 00 ... 31: ZU																					
00	01	02	03	04	05	06	07	08	09	10	11	12	13	14	15	16	17	18	19	20	...	30	31
M	M	M	O	O	O	J	J	E	E												...		

14 + 15 + 16 + 17 + 18 + 19

Ordering Table		Width	0.71 in	1.02 in	1.65 in – size 1	Conditions	Code	Enter code
↓	14	Pneumatic valve positions 00 ... 31					-	-
	0	Valve position 00 ... 31	5/2-way valve, single solenoid with pneumatic spring return				M	Enter equipment selection for valve positions in order code
		5/2-way valve, single solenoid with spring return					O	
		5/2-way valve, double solenoid					J	
		5/2-way valve, double solenoid with dominant signal					D	
		2x 3/2-way valve, normally open			12		N	
		2x 3/2-way valve, normally closed			12		K	
		2x 3/2-way valve, 1x normally closed, 1x normally open			12		H	
		5/3-way valve, mid-position pressurised					B	
		5/3-way valve, mid-position closed					G	
		5/3-way valve, mid-position exhausted					E	
		2x 3/2-way valve, normally open, reverse operation			13		P	
		2x 3/2-way valve, normally closed, reverse operation			13		Q	
		2x 3/2-way valve, 1x normally closed, 1x normally open, reverse operation			13		R	
		Vacant position					L	
	15	Pressure regulator for valve position 00 ... 31	Input pressure 147 psi	Pressure regulator plate for port 1		14	ZA	
				Pressure regulator plate for port 4			ZB	
				Pressure regulator plate for port 2			ZC	
				Pressure regulator plate for port 4/2			ZD	
				Pressure regulator plate for port 4/2, reversible		15	ZE	
				Pressure regulator plate for port 4, reversible		15	ZK	
				Pressure regulator plate for port 2, reversible		15	ZL	
			Input pressure 88 psi	Pressure regulator plate for port 1		14	ZF	
				Pressure regulator plate for port 4			ZG	
				Pressure regulator plate for port 2			ZH	
				Pressure regulator plate for port 4/2			ZI	
				Pressure regulator plate for port 4/2, reversible		15	ZJ	
				Pressure regulator plate for port 4, reversible		15	ZM	
				Pressure regulator plate for port 2, reversible		15	ZN	

- 12 N, K, H Not permitted in zones with reverse operation. Not with pressure regulator (15) ZE, ZJ (reversible pressure regulator plate)
- 13 P, Q, R Only permissible in zones with reverse operation or with pressure regulator (15) ZE, ZJ (reversible pressure regulator plate). Pilot pressure required on duct 12 (ducted exhaust air not possible). Not with right-hand end plate (4) Y, Z
- 14 ZA, ZF Not permitted in zones with reverse operation.
- 15 ZE, ZK, ZL, ZJ, ZM, ZN Not permitted in zones with reverse operation. Not with 2x 3/2-way valves (14) N, K, H

Ordering Data – Configurable Products

Valve Manifolds Type 44 VTSA, NPT Thread for CPX – Pneumatic Part



➔ **0 Options**

Pneumatic accessories

U, ...B, ...T, ...N, ...V

+ **10N**
20

Ordering Table							
Width	0.71 in	1.02 in	1.65 in – size 1	Conditions	Code	Enter code	
16	Pressure indicator for valve position 00 ... 31	Pressure gauge, 147 psi		16	T	Enter equipment selection for valve positions in order code	
		Pressure gauge, 88 psi		17	U		
17	Flow control valve for valve position 00 ... 31	Flow control plate		18	X		
18	Vertical isolating plate for valve position 00 ... 31	Pressure separator plate on valve assembly		19	ZT		
19	Vertical supply plate for valve position 00 ... 31	Compressed air supply on valve		18	ZU		
20	Pneumatic accessories				+		+
	Mounting brackets (pack of 5)	Supplied separately		20	U		
	Inscription label holder for valves	5 ... 50			...B		
	Inscription label holder for manifold subbases	5 ... 50			...T		
	Cover cap for manual override, pushing	10 ... 90			...N		
	Cover cap for manual override, covered	10 ... 90			...V		

- 16 T Only with pressure regulator (15) ZA, ZB, ZC, ZD, ZE
- 17 U Only with pressure regulator (15) ZF, ZG, ZH, ZI, ZJ
- 18 X, ZU Not with valves with reverse operation (14) P, Q, R

- 19 ZT Not with right-hand end plate (4) Y, Z
- 20 U Can only be selected if there are more than 9 valve positions. Cannot be combined with DIN H-rail

Ordering Data – Configurable Products

Valve Manifolds Type 44 VTSA, NPT Thread for CPX – Pneumatic Part



Sizes of Pneumatic Connections						
	Code	Duct	Width			
			0.71 in	1.02 in	1.65 in – size 1	
7			Configuration of all pneumatic connections			
4	Right-hand end plate V, X, Y, U, Z, W	M	12, 14	1/4 NPT (QS-1/4-3/8-U)	1/4 NPT (QS-1/4-3/8-U)	1/4 NPT (QS-1/4-3/8-U)
		G	12, 14	1/4 NPT (QS-1/4-3/8-U)	1/4 NPT (QS-1/4-3/8-U)	1/4 NPT (QS-1/4-3/8-U)
		N	12, 14	1/4 NPT (QS-1/4-5/16-U)	1/4 NPT (QS-1/4-5/16-U)	1/4 NPT (QS-1/4-5/16-U)
4	Right-hand end plate V, X, U	M	1, 3, 5	1/2 NPT (QS-1/2-5/8-U)	1/2 NPT (QS-1/2-5/8-U)	1/2 NPT (QS-1/2-5/8-U)
		G	1, 3, 5	1/2 NPT (QS-1/2-5/8-U)	1/2 NPT (QS-1/2-5/8-U)	1/2 NPT (QS-1/2-5/8-U)
		N	1, 3, 5	1/2 NPT (QS-1/2-1/2-U)	1/2 NPT (QS-1/2-1/2-U)	1/2 NPT (QS-1/2-1/2-U)
9	Left-hand supply plate X	M	1, 3, 5	1/2 NPT (QS-1/2-5/8-U)	1/2 NPT (QS-1/2-5/8-U)	1/2 NPT (QS-1/2-5/8-U)
		G	1, 3, 5	1/2 NPT (QS-1/2-5/8-U)	1/2 NPT (QS-1/2-5/8-U)	1/2 NPT (QS-1/2-5/8-U)
		N	1, 3, 5	1/2 NPT (QS-1/2-1/2-U)	1/2 NPT (QS-1/2-1/2-U)	1/2 NPT (QS-1/2-1/2-U)
11	Type of interlinking block Large A, B, C, E, F, G	M	2, 4	1/8 NPT (QS-1/8-5/16-U)	1/4 NPT (QS-1/4-3/8-U)	3/8 NPT (QS-3/8-1/2-U)
11	Type of interlinking block Small AK, BK, CK, EK, FK, GK	N	2, 4	1/8 NPT (QS-1/8-1/4-U)	1/4 NPT (QS-G1/4-5/16-U)	3/8 NPT (QS-3/8-3/8-U)

Ordering Data – Configurable Products

Valve Manifolds Type 45 VTSA-F, NPT Thread for Multi-pin Plug – Electrical Part

M Mandatory Data				O Options		
Module No.	Valve manifold, electrical part	Electrical connection	Voltage	Connecting cable for multi-pin plug connection	User's manual	DIN H-rail mounting
547964	45E	T, MP1, MP2, MP3, MP4	P, Q	GA, GB, GC, GD, GE, GF, GG, GH, GI, GK, GL, GM, GN, GO, GP, GQ, GR, GS	D, E, F, I, S, V	H
Order example						
547964	45E	- MP1	- P	+ GE	- D	- H
1	2	3	4	5	6	7

Ordering Table			Conditions	Code	Enter code	
M	1	Module No.	547964			
	2	Valve manifold, electrical part	Valve manifold type 45, VTSA-F, electrical multi-pin plug connection/manifold box		45E	
	3	Electrical connection	Multi-pin plug, CageClamp	1	-T	
			Electrical multi-pin plug connection, Sub-D (37-pin)	1	-MP1	
			Electrical multi-pin plug connection, individual connection with M12, 6-way	2	-MP2	
			Electrical multi-pin plug connection, individual connection with M12, 10-way	3	-MP3	
			Electrical multi-pin plug connection, round plug connector (19-pin), M23	4	-MP4	
	4	Voltage	24 V DC		-P	
			110 V AC	5	-Q	
O	5	Electrical accessories			+	
	6	Connecting cable for Polyurethane multi-pin plug connection, e pre-assembled, supplied loose	Connecting cable for Sub-D, 8.2 ft, 10-core, 8 solenoid coils	6	GA	
			Connecting cable for Sub-D, 16.4 ft, 10-core, 8 solenoid coils	6	GB	
			Connecting cable for Sub-D, 32.8 ft, 10-core, 8 solenoid coils	6	GC	
			Connecting cable for Sub-D, 8.2 ft, 26-core, 22 solenoid coils	6	GD	
			Connecting cable for Sub-D, 16.4 ft, 26-core, 22 solenoid coils	6	GE	
			Connecting cable for Sub-D, 32.8 ft, 26-core, 22 solenoid coils	6	GF	
			Connecting cable for Sub-D, 8.2 ft, 37-core, 32 solenoid coils	6	GG	
			Connecting cable for Sub-D, 16.4 ft, 37-core, 32 solenoid coils	6	GH	
			Connecting cable for Sub-D, 32.8 ft, 37-core, 32 solenoid coils	6	GI	
			Polyvinyl chloride	Connecting cable for Sub-D, 8.2 ft, 10-core, 8 solenoid coils	6	GK
				Connecting cable for Sub-D, 16.4 ft, 10-core, 8 solenoid coils	6	GL
				Connecting cable for Sub-D, 32.8 ft, 10-core, 8 solenoid coils	6	GM
				Connecting cable for Sub-D, 8.2 ft, 27-core, 22 solenoid coils	6	GN
				Connecting cable for Sub-D, 16.4 ft, 27-core, 22 solenoid coils	6	GO
				Connecting cable for Sub-D, 32.8 ft, 27-core, 22 solenoid coils	6	GP
				Connecting cable for Sub-D, 8.2 ft, 37-core, 32 solenoid coils	6	GQ
				Connecting cable for Sub-D, 16.4 ft, 37-core, 32 solenoid coils	6	GR
				Connecting cable for Sub-D, 32.8 ft, 37-core, 32 solenoid coils	6	GS
			7	User's manual	German	
	English				-E	
	French				-F	
	Italian				-I	
	Spanish				-S	
	Swedish				-V	
	7	DIN H-rail mounting	1		-H	

- 1 T, MP1 Max. 32 addresses can be selected
- 2 MP2 Max. 12 addresses can be selected
- 3 MP3 Max. 20 addresses can be selected

- 4 MP4 Max. 16 addresses can be selected
- 5 Q Only with electrical connection (3) T (multi-pin plug, CageClamp)
- 6 G... Not with electrical connection (3) T, MP2, MP3 and MP4

Ordering Data – Configurable Products

Valve Manifolds Type 45 VTSA-F, NPT Thread for Multi-pin Plug – Pneumatic Part

M Mandatory Data				O Options					
Module No.	Valve manifold, pneumatic part	Manual override	Right-hand end plate	Port configuration for supply plates	Pneumatic supply to valve manifold	Configuration of all pneumatic connections	Outgoing direction of all working lines	Left-hand supply plate	Reverse operation
547964	45PN	N, R, V	V, X, Y, U, Z, W	K, L	S, V	M, N, G	P	X	Z
Order example									
547964	45PN	R	V	K	S	M	P	X	
1	2	3	4	5	6	7	8	9	10

Ordering Table		Width	0.71 in	1.02 in	Conditions	Code	Enter code
M	1	Module No.	547964	547964			
	2	Valve manifold, pneumatic part	Valve manifold type 45, VTSA-F, modular subbase valves, optimised for flow rate, pneumatic connections with NPT thread			45PN	
	3	Manual override	Pushing (non-detenting)			-N	
			Pushing/detenting			-R	
			Covered			-V	
	4	Right-hand end plate	Right-hand end plate, with supply air/exhaust air, internal pilot air supply			-V	
			Right-hand end plate with supply air/exhaust air, external pilot air supply			-X	
			End plate with pilot air selector, internal pilot air supply		1	-Y	
			End plate with pilot air selector, internal pilot air supply, ducted pilot exhaust air		1	-U	
			End plate with pilot air selector, external pilot air supply		1	-Z	
			End plate with pilot air selector, external pilot air supply, ducted pilot exhaust air		1	-W	
	5	Port configuration for supply plates	Normal operation: Supply port 1, exhaust port 3/5 separated		2	-K	
			Reverse operation: Exhaust port 1, supply port 3/5 separated				
			Normal operation: Supply port 1, exhaust port 3/5 common		2	-L	
			Reverse operation: Exhaust port 1, supply port 3/5 common				
	6	Pneumatic valve manifold supply (standard: threaded connection)	Silencer and QS push-in fittings			S	
			QS push-in fittings			V	
	7	Configuration of all pneumatic connections	QS push-in fittings, large		3	M	
			QS push-in fittings, small		3	N	
			QS push-in fittings, large and small mixed		3	G	
	8	Outgoing direction of all working lines (standard outlet at front)	90° connection plate, outlet at bottom			P	
	9	Left-hand supply plate	Left-hand supply plate in front of manifold subbase 00			X	
	10	Reverse operation	Reverse operation as of valve position 00		4	Z	

- 1 **Y, U, Z, W** At least one left-hand supply plate (9) X or one compressed air supply/duct separation (12) U, SU, TU, RU, USU, UTU or URU must be selected
- 2 **K, L** Must be selected if left-hand supply plate (9) X or one compressed air supply/duct separation (12) (S, T, R, U, SU, US, TU, UT, RU, UR, USU, UTU, URU) was selected
- 3 **M, N, G** Must be selected if pneumatic valve manifold supply (6) S or V was selected
- 4 **Z** A reversible pressure zone cannot be terminated with a right-hand end plate (4) V, Y, U (internal pilot air supply)

Ordering Data – Configurable Products



Valve Manifolds Type 45 VTSA-F, NPT Thread for Multi-pin Plug – Pneumatic Part

→ 0 Options →

Pneumatic manifold subbases 00 ... 15

11 Type of interlinking block: A, B, E, F, AK, BK, EK, FK
 12 Compressed air supply/duct separation: S, T, R, U, SU, US, TU, UT, RU, UR, USU, UTU, URU
 13 Reverse operation: Z

Module position

00	01	02	03	04	05	06	07	08	09	10	11	12	13	14	15
A	B	B	BS	B											

11 + 12 + 13

Ordering Table		Width	0.71 in	1.02 in	Conditions	Code	Enter code
↓	11	Pneumatic manifold subbases			5	-	-
0		Type of interlinking block 00 ... 15	2 valve positions, 4 addresses	-		A	Enter the equipment selected in the order code
		Manifold subbase	-	2 valve positions, 4 addresses		B	
			2 valve positions, 2 addresses	-	6	E	
			-	2 valve positions, 2 addresses	6	F	
		Manifold subbase with QS push-in fittings, small	2 valve positions, 4 addresses	-	7	AK	
			-	2 valve positions, 4 addresses	7	BK	
			2 valve positions, 2 addresses	-	8	EK	
			-	2 valve positions, 2 addresses	8	FK	
	12	Compressed air supply/duct separation 00 ... 15	Duct separation 1, 3, 5		9 10	S	
			Duct separation 1		9 10	T	
			Duct separation 3, 5		9 10	R	
			Supply plate			U	
			Supply plate with duct separation 1, 3, 5 at left		9	SU	
			Supply plate with duct separation 1, 3, 5 at right		9	US	
			Supply plate with duct separation 1 at left		9	TU	
			Supply plate with duct separation 1 at right		9	UT	
			Supply plate with duct separation 3, 5 at left		9	RU	
			Supply plate with duct separation 3, 5 at right		9	UR	
			2 supply plates with duct separation 1, 3, 5 in centre			USU	
			2 supply plates with duct separation 1 in centre			UTU	
			2 supply plates with duct separation 3, 5 in centre			URU	
↓	13	Reverse operation 00 ... 15	Subsequent valve positions permitted for reverse operation		11	Z	

- 5 Manifold subbases must be fitted throughout without any gaps
- 6 E, F Only with valves (14) M, O and L
- 7 AK, BK Only with configuration of all pneumatic connections (7) N or G
- 8 EK, FK Only with configuration of all pneumatic connections (7) N or G
Only with valves (14) M, O and L

- 9 S, T, R, SU, US, TU, UT, RU, UR No pressure-free zones may be created
Cannot be selected on last manifold subbase
- 10 S, T, R Only with compressed air supply/duct separation (12) S, SU, US or USU.
- 11 Z A reversible pressure zone cannot be terminated with a right-hand end plate (4) V, Y, U

Ordering Data – Configurable Products

Valve Manifolds Type 45 VTSA-F, NPT Thread for Multi-pin Plug – Pneumatic Part



→ 0 Options →

Pneumatic valve positions 00 ... 31

- 14 Valve position 00 ... 31: M, O, J, D, N, K, H, B, G, E, P, Q, R, L
- 15 Pressure regulator for position 00 ... 31: ZA, ZB, ZC, ZD, ZE, ZK, ZL, ZF, ZG, ZH, ZI, ZJ, ZM, ZN
- 16 Pressure indicator for position 00 ... 31: T, U
- 17 Flow control valve position 00 ... 31: X
- 18 Vertical pressure isolating plate for position 00 ... 31: ZT
- 19 Vertical supply plate for position 00 ... 31: ZU

Valve position		19 Vertical supply plate for position 00 ... 31: ZU																					
00	01	02	03	04	05	06	07	08	09	10	11	12	13	14	15	16	17	18	19	20	...	30	31
M	M	M	O	O	O	J	J	E	E												...		

14 + 15 + 16 + 17 + 18 + 19

Ordering Table		Width	0.71 in	1.02 in	Conditions	Code	Enter code	
↓	14	Pneumatic valve positions 00 ... 31				-	-	
	0	Valve position 00 ... 31	5/2-way valve, single solenoid with pneumatic spring return			M	Enter equipment selection for valve positions in order code	
		5/2-way valve, single solenoid with spring return				O		
		5/2-way valve, double solenoid				J		
		5/2-way valve, double solenoid with dominant signal				D		
		2x 3/2-way valve, normally open		12		N		
		2x 3/2-way valve, normally closed		12		K		
		2x 3/2-way valve, 1x normally closed, 1x normally open		12		H		
		5/3-way valve, mid-position pressurised				B		
		5/3-way valve, mid-position closed				G		
		5/3-way valve, mid-position exhausted				E		
		2x 3/2-way valve, normally open, reverse operation		13		P		
		2x 3/2-way valve, normally closed, reverse operation		13		Q		
		2x 3/2-way valve, 1x normally closed, 1x normally open, reverse operation		13		R		
		Vacant position				L		
↓	15	Pressure regulator for valve position 00 ... 31	Input pressure 147 psi	Pressure regulator plate for port 1		14		ZA
				Pressure regulator plate for port 4				ZB
		Pressure regulator plate for port 2			ZC			
		Pressure regulator plate for port 4/2			ZD			
		Pressure regulator plate for port 4/2, reversible		15	ZE			
		Pressure regulator plate for port 4, reversible		15	ZK			
		Pressure regulator plate for port 2, reversible		15	ZL			
		Input pressure 88 psi	Pressure regulator plate for port 1		14	ZF		
		Pressure regulator plate for port 4			ZG			
		Pressure regulator plate for port 2			ZH			
		Pressure regulator plate for port 4/2			ZI			
		Pressure regulator plate for port 4/2, reversible		15	ZJ			
		Pressure regulator plate for port 4, reversible		15	ZM			
		Pressure regulator plate for port 2, reversible		15	ZN			

- 12 N, K, H Not permitted in zones with reverse operation. Not with pressure regulator (15) ZE, ZJ (reversible pressure regulator plate)
- 13 P, Q, R Only permissible in zones with reverse operation or with pressure regulator (15) ZE, ZJ (reversible pressure regulator plate). Pilot pressure required on duct 12 (ducted exhaust air not possible). Not with right-hand end plate (4) Y, Z
- 14 ZA, ZF Not permitted in zones with reverse operation
- 15 ZE, ZK, ZL, ZJ, ZM, ZN Not permitted in zones with reverse operation. Not with 2x 3/2-way valves (14) N, K, H

Ordering Data – Configurable Products

Valve Manifolds Type 45 VTSA-F, NPT Thread for Multi-pin Plug – Pneumatic Part

➔ **0 Options**

Pneumatic accessories

U, ...B, ...T, ...N, ...V

+ **10N**
20

Ordering Table						
Width	0.71 in	1.02 in	Conditions	Code	Enter code	
↓ 0	16 Pressure indicator for valve position 00 ... 31	Pressure gauge, 147 psi	16	T	Enter equipment selection for valve positions in order code	
		Pressure gauge, 88 psi	17	U		
17 Flow control valve for valve position 00 ... 31	Flow control plate	18	X			
18 Vertical isolating plate for valve position 00 ... 31	Pressure separator plate on valve assembly	19	ZT			
19 Vertical supply plate for valve position 00 ... 31	Compressed air supply on valve	18	ZU			
20 Pneumatic accessories				+		+
	Mounting brackets (pack of 5)	Supplied separately	20	U		
	Inscription label holder for valves	5 ... 50		...B		
	Inscription label holder for manifold subbases	5 ... 50		...T		
	Cover cap for manual override, pushing	10 ... 90		...N		
	Cover cap for manual override, covered	10 ... 90		...V		

- 16 T Only with pressure regulator (15) ZA, ZB, ZC, ZD, ZE
- 17 U Only with pressure regulator (15) ZF, ZG, ZH, ZI, ZJ
- 18 X, ZU Not with valves with reverse operation (14) P, Q, R

- 19 ZT Not with right-hand end plate (4) Y, Z
- 20 U Can only be selected if there are more than 9 valve positions

Ordering Data – Configurable Products

Valve Manifolds Type 45 VTSA-F, NPT Thread for CPX – Pneumatic Part

M Mandatory Data				O Options					
Module No.	Valve manifold, pneumatic part	Manual override	Right-hand end plate	Port configuration for supply plates	Pneumatic supply to valve manifold	Configuration of all pneumatic connections	Outgoing direction of all working lines	Left-hand supply plate	Reverse operation
547966	45PN	N, R, V	V, X, Y, U, Z, W	K, L	S, V	M, N, G	P	X	Z
Order example	45PN	- R	- V	- K	S	M	P	X	
1	2	3	4	5	6	7	8	9	10

Ordering table		Width	0.71 in	1.02 in	Conditions	Code	Enter code
M	1	Module No.	547966	547966			
	2	Valve manifold, pneumatic part	Valve manifold type 45, VTSA-F, modular subbase valves, optimized for flow rate, pneumatic connections with NPT thread			45PN	
	3	Manual override	Pushing (non-detenting)			-N	
			Pushing/detenting			-R	
			Covered			-V	
	4	Right-hand end plate	Right-hand end plate, with supply air/exhaust air, internal pilot air supply			-V	
			Right-hand end plate with supply air/exhaust air, external pilot air supply			-X	
			End plate with pilot air selector, internal pilot air supply			1 -Y	
			End plate with pilot air selector, internal pilot air supply, ducted pilot exhaust air			1 -U	
			End plate with pilot air selector, external pilot air supply			1 -Z	
			End plate with pilot air selector, external pilot air supply, ducted pilot exhaust air			1 -W	
	5	Port configuration for supply plates	Normal operation: Supply port 1, exhaust port 3/5 separated			2 -K	
			Reverse operation: Exhaust port 1, supply port 3/5 separated				
			Normal operation: Supply port 1, exhaust port 3/5 common			2 -L	
			Reverse operation: Exhaust port 1, supply port 3/5 common				
	6	Pneumatic valve manifold supply (standard: threaded connection)	Silencer and QS push-in fittings			S	
			QS push-in fittings			V	
	7	Configuration of all pneumatic connections	QS push-in fittings, large			3 M	
			QS push-in fittings, small			3 N	
			QS push-in fittings, large and small mixed			3 G	
	8	Outgoing direction of all working lines (standard outlet at front)	90° connection plate, outlet at bottom			P	
	9	Left-hand supply plate	Left-hand supply plate in front of manifold subbase 00			X	
	10	Reverse operation	Reverse operation as of valve position 00			4 Z	

- 1 **Y, U, Z, W** At least one left-hand supply plate (9) X or one compressed air supply/duct separation (12) U, SU, TU, RU, USU, UTU or URU must be selected
- 2 **K, L** Must be selected if left-hand supply plate (9) X or one compressed air supply/duct separation (12) (S, T, R, U, SU, US, TU, UT, RU, UR, USU, UTU, URU) was selected
- 3 **M, N, G** Must be selected if pneumatic valve Manifold supply (6) S or V was selected
- 4 **Z** A reversible pressure zone cannot be terminated with a right-hand end plate (4) V, Y, U (internal pilot air supply)

Ordering Data – Configurable Products



Valve Manifolds Type 45 VTSA-F, NPT Thread for CPX – Pneumatic Part

→ 0 Options →

Pneumatic manifold subbases 00 ... 15

11 Type of interlinking block: A, B, E, F, AK, BK, EK, FK
 12 Compressed air supply/duct separation: S, T, R, U, SU, US, TU, UT, RU, UR, USU, UTU, URU
 13 Reverse operation: Z

Module position

00	01	02	03	04	05	06	07	08	09	10	11	12	13	14	15
A	B	B	BS	B											

11 + 12 + 13

Ordering Table		Width	0.71 in	1.02 in	Conditions	Code	Enter code
0	11 Pneumatic manifold subbases				5	-	-
	Type of interlinking block 00 ... 15	Manifold subbase	2 valve positions, 4 addresses	-		A	Enter the equipment selected in the order code
			-	2 valve positions, 4 addresses		B	
		Manifold subbase with QS push-in fittings, small	2 valve positions, 2 addresses	-	6	E	
			-	2 valve positions, 2 addresses	6	F	
			2 valve positions, 4 addresses	-	7	AK	
			-	2 valve positions, 4 addresses	7	BK	
	12 Compressed air supply/duct separation 00 ... 15		2 valve positions, 2 addresses	-	8	EK	
			-	2 valve positions, 2 addresses	8	FK	
			Duct separation 1, 3, 5		9 10	S	
			Duct separation 1		9 10	T	
			Duct separation 3, 5		9 10	R	
			Supply plate			U	
Supply plate with duct separation 1, 3, 5 at left				9	SU		
Supply plate with duct separation 1, 3, 5 at right		9	US				
Supply plate with duct separation 1 at left		9	TU				
Supply plate with duct separation 1 at right		9	UT				
Supply plate with duct separation 3, 5 at left		9	RU				
Supply plate with duct separation 3, 5 at right		9	UR				
2 supply plates with duct separation 1, 3, 5 in centre			USU				
2 supply plates with duct separation 1 in centre			UTU				
2 supply plates with duct separation 3, 5 in centre			URU				
13 Reverse operation 00 ... 15		Subsequent valve positions permitted for reverse operation		11	Z		

- 5 Manifold subbases must be fitted throughout without any gaps
- 6 E, F Only with valves (14) M, O and L
- 7 AK, BK Only with configuration of all pneumatic connections (7) N or G
- 8 EK, FK Only with configuration of all pneumatic connections (7) N or G
Only with valves (14) M, O and L

- 9 S, T, R, SU, US, TU, UT, RU, UR No pressure-free zones may be created
Cannot be selected on last manifold subbase
- 10 S, T, R Only with compressed air supply/duct separation (12) S, SU, US or USU.
- 11 Z A reversible pressure zone cannot be terminated with a right-hand end plate (4) V, Y, U

Ordering Data – Configurable Products

Valve Manifolds Type 45 VTSA-F, NPT Thread for CPX – Pneumatic Part



→ 0 Options →

Pneumatic valve positions 00 ... 31

- 14 Valve position 00 ... 31: M, O, J, D, N, K, H, B, G, E, P, Q, R, L
- 15 Pressure regulator for position 00 ... 31: ZA, ZB, ZC, ZD, ZE, ZK, ZL, ZF, ZG, ZH, ZI, ZJ, ZM, ZN
- 16 Pressure indicator for position 00 ... 31: T, U
- 17 Flow control valve position 00 ... 31: X
- 18 Vertical pressure isolating plate for position 00 ... 31: ZT
- 19 Vertical supply plate for position 00 ... 31: ZU

Valve position		19 Vertical supply plate for position 00 ... 31: ZU																					
00	01	02	03	04	05	06	07	08	09	10	11	12	13	14	15	16	17	18	19	20	...	30	31
M	M	M	O	O	O	J	J	E	E												...		

14 + 15 + 16 + 17 + 18 + 19

Ordering Table		Width	0.71 in	1.02 in	Conditions	Code	Enter code	
↓	14	Pneumatic valve positions 00 ... 31				-	-	
	0	Valve position 00 ... 31	5/2-way valve, single solenoid with pneumatic spring return			M	Enter equipment selection for valve positions in order code	
		5/2-way valve, single solenoid with spring return				O		
		5/2-way valve, double solenoid				J		
		5/2-way valve, double solenoid with dominant signal				D		
		2x 3/2-way valve, normally open		12		N		
		2x 3/2-way valve, normally closed		12		K		
		2x 3/2-way valve, 1x normally closed, 1x normally open		12		H		
		5/3-way valve, mid-position pressurised				B		
		5/3-way valve, mid-position closed				G		
		5/3-way valve, mid-position exhausted				E		
		2x 3/2-way valve, normally open, reverse operation		13		P		
		2x 3/2-way valve, normally closed, reverse operation		13		Q		
		2x 3/2-way valve, 1x normally closed, 1x normally open, reverse operation		13		R		
		Vacant position				L		
↓	15	Pressure regulator for valve position 00 ... 31	Input pressure 147 psi	Pressure regulator plate for port 1		14		ZA
				Pressure regulator plate for port 4				ZB
		Pressure regulator plate for port 2			ZC			
		Pressure regulator plate for port 4/2			ZD			
		Pressure regulator plate for port 4/2, reversible		15	ZE			
		Pressure regulator plate for port 4, reversible		15	ZK			
		Pressure regulator plate for port 2, reversible		15	ZL			
		Input pressure 88 psi	Pressure regulator plate for port 1		14		ZF	
		Pressure regulator plate for port 4					ZG	
		Pressure regulator plate for port 2					ZH	
		Pressure regulator plate for port 4/2					ZI	
		Pressure regulator plate for port 4/2, reversible		15			ZJ	
		Pressure regulator plate for port 4, reversible		15			ZM	
		Pressure regulator plate for port 2, reversible		15			ZN	

- 12 N, K, H Not permitted in zones with reverse operation. Not with pressure regulator (15) ZE, ZJ (reversible pressure regulator plate)
- 13 P, Q, R Only permissible in zones with reverse operation or with pressure regulator (15) ZE, ZJ (reversible pressure regulator plate). Pilot pressure required on duct 12 (ducted exhaust air not possible). Not with right-hand end plate (4) Y, Z
- 14 ZA, ZF Not permitted in zones with reverse operation.
- 15 ZE, ZK, ZL, ZJ, ZM, ZN Not permitted in zones with reverse operation. Not with 2x 3/2-way valves (14) N, K, H

Ordering Data – Configurable Products



Valve Manifolds Type 45 VTSA-F, NPT Thread for CPX – Pneumatic Part

➔ **0 Options**

Pneumatic accessories

U, ...B, ...T, ...N, ...V

+ **10N**

20

Ordering Table						
Width	0.71 in	1.02 in	Conditions	Code	Enter code	
16	Pressure indicator for valve position 00 ... 31	Pressure gauge, 147 psi	16	T	Enter equipment selection for valve positions in order code	
		Pressure gauge, 88 psi	17	U		
17	Flow control valve for valve position 00 ... 31	Flow control plate	18	X		
18	Vertical isolating plate for valve position 00 ... 31	Pressure separator plate on valve assembly	19	ZT		
19	Vertical supply plate for valve position 00 ... 31	Compressed air supply on valve	18	ZU		
20	Pneumatic accessories			+		+
	Mounting brackets (pack of 5)	Supplied separately	20	U		
	Inscription label holder for valves	5 ... 50		...B		
	Inscription label holder for manifold subbases	5 ... 50		...T		
	Cover cap for manual override, pushing	10 ... 90		...N		
	Cover cap for manual override, covered	10 ... 90		...V		

- 16 T Only with pressure regulator (15) ZA, ZB, ZC, ZD, ZE
- 17 U Only with pressure regulator (15) ZF, ZG, ZH, ZI, ZJ
- 18 X, ZU Not with valves with reverse operation (14) P, Q, R

- 19 ZT Not with right-hand end plate (4) Y, Z
- 20 U Can only be selected if there are more than 9 valve positions. Cannot be combined with DIN H-rail

Ordering Data – Configurable Products

Valve Manifolds Type 45 VTSA-F, NPT Thread for CPX – Pneumatic Part

FESTO

Sizes of Pneumatic Connections					
		Code	Duct	Width	
				0.71 in	1.02 in
7		Configuration of all pneumatic connections			
4	Right-hand end plate V, X, Y, U, Z, W	M	12, 14	1/4 NPT (QS-1/4-3/8-U)	1/4 NPT (QS-1/4-3/8-U)
		G	12, 14	1/4 NPT (QS-1/4-3/8-U)	1/4 NPT (QS-1/4-3/8-U)
		N	12, 14	1/4 NPT (QS-1/4-5/16-U)	1/4 NPT (QS-1/4-5/16-U)
4	Right-hand end plate V, X, U	M	1, 3, 5	1/2 NPT (QS-1/2-5/8-U)	1/2 NPT (QS-1/2-5/8-U)
		G	1, 3, 5	1/2 NPT (QS-1/2-5/8-U)	1/2 NPT (QS-1/2-5/8-U)
		N	1, 3, 5	1/2 NPT (QS-1/2-1/2-U)	1/2 NPT (QS-1/2-1/2-U)
9	Left-hand supply plate X	M	1, 3, 5	1/2 NPT (QS-1/2-5/8-U)	1/2 NPT (QS-1/2-5/8-U)
		G	1, 3, 5	1/2 NPT (QS-1/2-5/8-U)	1/2 NPT (QS-1/2-5/8-U)
		N	1, 3, 5	1/2 NPT (QS-1/2-1/2-U)	1/2 NPT (QS-1/2-1/2-U)
11	Type of interlinking block Large A, B, E, F	M	2, 4	1/8 NPT (QS-1/8-5/16-U)	1/4 NPT (QS-1/4-3/8-U)
11	Type of interlinking block Small AK, BK, EK, FK	N	2, 4	1/8 NPT (QS-1/8-1/4-U)	1/4 NPT (QS-G1/4-5/16-U)

Ordering Data – Individual Valve

Valve Manifolds Type 44 VTSA, Type 45 VTSA-F – Inch Series



Ordering Data					
	Code	Valve function	Width	Type	Part No.
Solenoid valves, 24 V DC					
	M	5/2-way valve, single solenoid, pneumatic spring return	0.71 in	VSVA-B-M52-AZD-A2-1T1L	539184
			1.02 in	VSVA-B-M52-AZD-A1-1T1L	539158
			1.65 in ¹⁾	VSVA-B-M52-AZD-D1-1T1L	543698
	O	5/2-way valve, single solenoid, spring return	0.71 in	VSVA-B-M52-MZD-A2-1T1L	539185
			1.02 in	VSVA-B-M52-MZD-A1-1T1L	539159
			1.65 in ¹⁾	VSVA-B-M52-MZD-D1-1T1L	543699
	J	5/2-way valve, double solenoid, bistable	0.71 in	VSVA-B-B52-ZD-A2-1T1L	539182
			1.02 in	VSVA-B-B52-ZD-A1-1T1L	539156
			1.65 in ¹⁾	VSVA-B-B52-ZD-D1-1T1L	543696
	D	5/2-way valve, double solenoid, dominant signal	0.71 in	VSVA-B-D52-ZD-A2-1T1L	539183
			1.02 in	VSVA-B-D52-ZD-A1-1T1L	539157
			1.65 in ¹⁾	VSVA-B-D52-ZD-D1-1T1L	543697
	N	2x 3/2-way valve, single solenoid, normally open	0.71 in	VSVA-B-T32U-AZD-A2-1T1L	539178
			1.02 in	VSVA-B-T32U-AZD-A1-1T1L	539152
			1.65 in ¹⁾	VSVA-B-T32U-AZD-D1-1T1L	543692
	K	2x 3/2-way valve, single solenoid, normally closed	0.71 in	VSVA-B-T32C-AZD-A2-1T1L	539176
			1.02 in	VSVA-B-T32C-AZD-A1-1T1L	539150
			1.65 in ¹⁾	VSVA-B-T32C-AZD-D1-1T1L	543690
	H	2x 3/2-way valve, single solenoid, 1x normally open, 1x normally closed	0.71 in	VSVA-B-T32H-AZD-A2-1T1L	539180
			1.02 in	VSVA-B-T32H-AZD-A1-1T1L	539154
			1.65 in ¹⁾	VSVA-B-T32H-AZD-D1-1T1L	543694
	B	5/3-way valve, mid-position pressurised	0.71 in	VSVA-B-P53U-ZD-A2-1T1L	539186
			1.02 in	VSVA-B-P53U-ZD-A1-1T1L	539160
			1.65 in ¹⁾	VSVA-B-P53U-ZD-D1-1T1L	543700
	G	5/3-way valve, mid-position closed	0.71 in	VSVA-B-P53C-ZD-A2-1T1L	539188
			1.02 in	VSVA-B-P53C-ZD-A1-1T1L	539162
			1.65 in ¹⁾	VSVA-B-P53C-ZD-D1-1T1L	543702
	E	5/3-way valve, mid-position exhausted	0.71 in	VSVA-B-P53E-ZD-A2-1T1L	539187
			1.02 in	VSVA-B-P53E-ZD-A1-1T1L	539161
			1.65 in ¹⁾	VSVA-B-P53E-ZD-D1-1T1L	543701
	P	2x 3/2-way valve, single solenoid, reverse operation, normally open	0.71 in	VSVA-B-T32F-AZD-A2-1T1L	539179
			1.02 in	VSVA-B-T32F-AZD-A1-1T1L	539153
			1.65 in ¹⁾	VSVA-B-T32F-AZD-D1-1T1L	543693
	Q	2x 3/2-way valve, single solenoid, reverse operation, normally closed	0.71 in	VSVA-B-T32N-AZD-A2-1T1L	539177
			1.02 in	VSVA-B-T32N-AZD-A1-1T1L	539151
			1.65 in ¹⁾	VSVA-B-T32N-AZD-D1-1T1L	543691
	R	2x 3/2-way valve, single solenoid, reverse operation, 1x normally open, 1x normally closed	0.71 in	VSVA-B-T32W-AZD-A2-1T1L	539181
			1.02 in	VSVA-B-T32W-AZD-A1-1T1L	539155
			1.65 in ¹⁾	VSVA-B-T32W-AZD-D1-1T1L	543695

1) Type 44 VTSA only

Ordering Data – Individual Valve

Valve Manifolds Type 44 VTSA, Type 45 VTSA-F – Inch Series



Ordering Data					
	Code	Valve function	Width	Type	Part No.
Solenoid valves, 110 V AC					
	M	5/2-way valve, single solenoid, pneumatic spring return	0.71 in	VSVA-B-M52-AZD-A2-2AT1L	539171
			1.02 in	VSVA-B-M52-AZD-A1-2AT1L	539145
			1.65 in ¹⁾	VSVA-B-M52-AZD-D1-2AT1L	543685
	O	5/2-way valve, single solenoid, spring return	0.71 in	VSVA-B-M52-MZD-A2-2AT1L	539172
			1.02 in	VSVA-B-M52-MZD-A1-2AT1L	539146
			1.65 in ¹⁾	VSVA-B-M52-MZD-D1-2AT1L	543686
	J	5/2-way valve, double solenoid, bistable	0.71 in	VSVA-B-B52-ZD-A2-2AT1L	539169
			1.02 in	VSVA-B-B52-ZD-A1-2AT1L	539143
			1.65 in ¹⁾	VSVA-B-B52-ZD-D1-2AT1L	543683
	D	5/2-way valve, double solenoid, dominant signal	0.71 in	VSVA-B-D52-ZD-A2-2AT1L	539170
			1.02 in	VSVA-B-D52-ZD-A1-2AT1L	539144
			1.65 in ¹⁾	VSVA-B-D52-ZD-D1-2AT1L	543684
	N	2x 3/2-way valve, single solenoid, normally open	0.71 in	VSVA-B-T32U-AZD-A2-2AT1L	539165
			1.02 in	VSVA-B-T32U-AZD-A1-2AT1L	539139
			1.65 in ¹⁾	VSVA-B-T32U-AZD-D1-2AT1L	543679
	K	2x 3/2-way valve, single solenoid, normally closed	0.71 in	VSVA-B-T32C-AZD-A2-2AT1L	539163
			1.02 in	VSVA-B-T32C-AZD-A1-2AT1L	539137
			1.65 in ¹⁾	VSVA-B-T32C-AZD-D1-2AT1L	543677
	H	2x 3/2-way valve, single solenoid, 1x normally open, 1x normally closed	0.71 in	VSVA-B-T32H-AZD-A2-2AT1L	539167
			1.02 in	VSVA-B-T32H-AZD-A1-2AT1L	539141
			1.65 in ¹⁾	VSVA-B-T32H-AZD-D1-2AT1L	543681
	B	5/3-way valve, mid-position pressurised	0.71 in	VSVA-B-P53U-ZD-A2-2AT1L	539173
			1.02 in	VSVA-B-P53U-ZD-A1-2AT1L	539147
			1.65 in ¹⁾	VSVA-B-P53U-ZD-D1-2AT1L	543687
	G	5/3-way valve, mid-position closed	0.71 in	VSVA-B-P53C-ZD-A2-2AT1L	539175
			1.02 in	VSVA-B-P53C-ZD-A1-2AT1L	539149
			1.65 in ¹⁾	VSVA-B-P53C-ZD-D1-2AT1L	543689
	E	5/3-way valve, mid-position exhausted	0.71 in	VSVA-B-P53E-ZD-A2-2AT1L	539174
			1.02 in	VSVA-B-P53E-ZD-A1-2AT1L	539148
			1.65 in ¹⁾	VSVA-B-P53E-ZD-D1-2AT1L	543688
	P	2x 3/2-way valve, single solenoid, reverse operation, normally open	0.71 in	VSVA-B-T32F-AZD-A2-2AT1L	539166
			1.02 in	VSVA-B-T32F-AZD-A1-2AT1L	539140
			1.65 in ¹⁾	VSVA-B-T32F-AZD-D1-2AT1L	543680
	Q	2x 3/2-way valve, single solenoid, reverse operation, normally closed	0.71 in	VSVA-B-T32N-AZD-A2-2AT1L	539164
			1.02 in	VSVA-B-T32N-AZD-A1-2AT1L	539138
			1.65 in ¹⁾	VSVA-B-T32N-AZD-D1-2AT1L	543678
	R	2x 3/2-way valve, single solenoid, reverse operation, 1x normally open, 1x normally closed	0.71 in	VSVA-B-T32W-AZD-A2-2AT1L	539168
			1.02 in	VSVA-B-T32W-AZD-A1-2AT1L	539142
			1.65 in ¹⁾	VSVA-B-T32W-AZD-D1-2AT1L	543682

1) Type 44 VTSA only

Accessories

Valve Manifolds Type 44 VTSA, Type 45 VTSA-F – Inch Series

FESTO

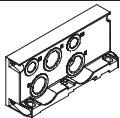
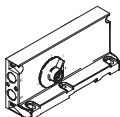
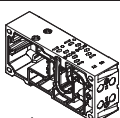
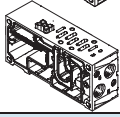
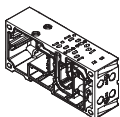
Ordering Data					
Designation	Code	Description	Width	Type	Part No.
Right-hand end plate					
	V	With supply air/exhaust air, internal pilot air supply, 1/2 NPT		VABE-S6-1R-N12	539235
	X	With supply air/exhaust air, external pilot air supply, 1/2 NPT		VABE-S6-1RZ-N12	539237
End plate with pilot air selector					
	Y	Internal pilot air supply		VABE-S6-1RZ-N-B1	539239
	U	Internal pilot air supply, ducted pilot exhaust air			
	Z	External pilot air supply			
	W	External pilot air supply, ducted pilot exhaust air			
Manifold subbase, port pattern to ISO 15407-2 and ISO 5599-2 – Type 44 VTSA					
 	A	2 valve positions, 4 addresses, for double solenoid valves	0.71 in	VABV-S4-2S-N18-2T2	539223
	B	2 valve positions, 4 addresses, for double solenoid valves	1.02 in	VABV-S4-1S-N14-2T2	539219
	C	1 valve position, 2 addresses, for double solenoid valves	1.65 in	VABV-S2-1S-N38-T2	542460
	E	2 valve positions, 2 addresses, for single solenoid valves	0.71 in	VABV-S4-2S-N18-2T1	539225
	F	2 valve positions, 2 addresses, for single solenoid valves	1.02 in	VABV-S4-1S-N14-2T1	539221
	G	1 valve position, 1 address, for single solenoid valves	1.65 in	VABV-S2-1S-N38-T1	542461
	Manifold subbase, optimised for flow rate – Type 45 VTSA-F				
	A	2 valve positions, 4 addresses, for double solenoid valves	0.71 in	VABV-S4-2HS-N18-2T2	546217
	B	2 valve positions, 4 addresses, for double solenoid valves	1.02 in	VABV-S4-1HS-N14-2T2	546213
	E	2 valve positions, 2 addresses, for single solenoid valves	0.71 in	VABV-S4-2HS-N18-2T1	546216
	F	2 valve positions, 2 addresses, for single solenoid valves	1.02 in	VABV-S4-1HS-N14-2T1	546212

Accessories

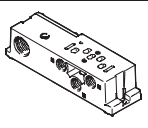
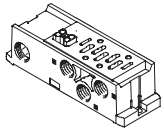
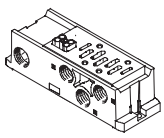

Valve Manifolds Type 44 VTSA, Type 45 VTSA-F – Inch Series

Ordering Data					
Designation	Code	Description	Width	Type	Part No.
Individual subbase, port pattern to ISO 15407-2, electrical connection with cable manifolds – Type 44 VTSA					
	NPT thread, internal pilot air supply				
	–	Connections at side, 1/8 NPT	0.71 in	VABS-S4-2S-N18-B-K2	541068
	–	Connections at side, 1/4 NPT	1.02 in	VABS-S4-1S-N14-B-K2	541066
	NPT thread, external pilot air supply				
	–	Connections at side, 1/8 NPT	0.71 in	VABS-S4-2S-N18-K2	539724
	–	Connections at side, 1/4 NPT	1.02 in	VABS-S4-1S-N14-K2	539726
Individual subbase, port pattern to ISO 5599-2, electrical connection with spring-loaded manifold – Type 44 VTSA					
	NPT thread, internal pilot air supply				
	–	Connections at side, 3/8 NPT	1.65 in	VABS-S2-1S-N38-B-C1	546763
	NPT thread, external pilot air supply				
	–	Connections at side, 3/8 NPT	1.65 in	VABS-S2-1S-N38-C1	546761
Individual subbase, port pattern to ISO 5599-2, electrical connection for self-assembly – Type 44 VTSA					
	NPT thread, internal pilot air supply				
	–	Connections at side, 3/8 NPT	1.65 in	VABS-S2-1S-N38-B-K1	546103
	NPT thread, external pilot air supply				
	–	Connections at side, 3/8 NPT	1.65 in	VABS-S2-1S-N38-K1	546100

Accessories

Valve Manifolds Type 44 VTSA, Type 45 VTSA-F – Inch Series

FESTO

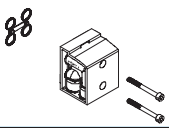
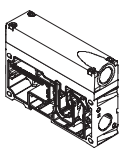
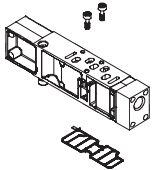
Ordering Data					
Designation	Code	Description	Width	Type	Part No.
Separator plate					
	S	Duct separation 1, 3, 5		VABD-S6-10-P3-C	539228
	T	Duct separation 1		VABD-S6-10-P1-C	539227
	R	Duct separation 3, 5		VABD-S6-10-P2-C	539229
90° connection plate					
	P	Outlet at bottom, connecting thread 1/8 NPT	0.71 in	VABF-S4-2-A2G2-N18	539720
	P	Outlet at bottom, connecting thread 1/4 NPT	1.02 in	VABF-S4-1-A2G2-N14	539722
	P	Outlet at bottom, connecting thread 3/8 NPT	1.65 in ¹⁾	VABF-S2-1-A1G2-N38	546098
Supply plate					
	L	With exhaust plate, 3/5 common, 1/2 NPT		VABF-S6-10-P1A7-N12	539233
	K	With exhaust port cover, 3/5 separated, 1/2 NPT		VABF-S6-10-P1A6-N12	539232
Vertical supply plate					
	ZU	Connecting thread 1/8 NPT	0.71 in	VABF-S4-2-P1A3-N18	540174
		Connecting thread 1/4 NPT	1.02 in	VABF-S4-1-P1A3-N14	540172
		Connecting thread 3/8 NPT	1.65 in ¹⁾	VABF-S2-1-P1A3-N38	546094

1) Type 44 VTSA only

Accessories

Valve Manifolds Type 44 VTSA, Type 45 VTSA-F – Inch Series



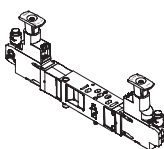

Ordering Data					
Designation	Code	Description	Width	Type	Part No.
Regulator plate					
	ZA	For port 1, 10 bar	0.71 in	VABF-S4-2-R1C2-C-10	540153
		For port 1, 10 bar	1.02 in	VABF-S4-1-R1C2-C-10	540154
		For port 1, 10 bar	1.65 in ¹⁾	VABF-S2-1-R1C2-C-10	546084
	ZF	For port 1, 6 bar	0.71 in	VABF-S4-2-R1C2-C-6	540151
		For port 1, 6 bar	1.02 in	VABF-S4-1-R1C2-C-6	540152
		For port 1, 6 bar	1.02 in	VABF-S4-1-R1C2-C-6E	549876
		For port 1, 6 bar	1.65 in ¹⁾	VABF-S2-1-R1C2-C-6	546083
	ZB	For port 4, 10 bar	0.71 in	VABF-S4-2-R3C2-C-10	540157
		For port 4, 10 bar	1.02 in	VABF-S4-1-R3C2-C-10	540158
		For port 4, 10 bar	1.65 in ¹⁾	VABF-S2-1-R3C2-C-10	546086
	ZG	For port 4, 6 bar	0.71 in	VABF-S4-2-R3C2-C-6	540155
		For port 4, 6 bar	1.02 in	VABF-S4-1-R3C2-C-6	540156
		For port 4, 6 bar	1.65 in ¹⁾	VABF-S2-1-R3C2-C-6	546085
	ZC	For port 2, 10 bar	0.71 in	VABF-S4-2-R2C2-C-10	540161
		For port 2, 10 bar	1.02 in	VABF-S4-1-R2C2-C-10	540162
		For port 2, 10 bar	1.65 in ¹⁾	VABF-S2-1-R2C2-C-10	546088
	ZH	For port 2, 6 bar	0.71 in	VABF-S4-2-R2C2-C-6	540159
		For port 2, 6 bar	1.02 in	VABF-S4-1-R2C2-C-6	540160
		For port 2, 6 bar	1.65 in ¹⁾	VABF-S2-1-R2C2-C-6	546087
	ZD	For ports 2 and 4, 10 bar	0.71 in	VABF-S4-2-R4C2-C-10	540165
		For ports 2 and 4, 10 bar	1.02 in	VABF-S4-1-R4C2-C-10	540166
		For ports 2 and 4, 10 bar	1.65 in ¹⁾	VABF-S2-1-R4C2-C-10	546090
	ZI	For ports 2 and 4, 6 bar	0.71 in	VABF-S4-2-R4C2-C-6	540163
		For ports 2 and 4, 6 bar	1.02 in	VABF-S4-1-R4C2-C-6	540164
		For ports 2 and 4, 6 bar	1.65 in ¹⁾	VABF-S2-1-R4C2-C-6	546089
	ZE	For ports 2 and 4, reversible, 10 bar	0.71 in	VABF-S4-2-R5C2-C-10	540169
		For ports 2 and 4, reversible, 10 bar	1.02 in	VABF-S4-1-R5C2-C-10	540170
		For ports 2 and 4, reversible, 10 bar	1.65 in ¹⁾	VABF-S2-1-R5C2-C-10	546092
	ZJ	For ports 2 and 4, reversible, 6 bar	0.71 in	VABF-S4-2-R5C2-C-6	540167
		For ports 2 and 4, reversible, 6 bar	1.02 in	VABF-S4-1-R5C2-C-6	540168
For ports 2 and 4, reversible, 6 bar		1.65 in ¹⁾	VABF-S2-1-R5C2-C-6	546091	
ZL	For port 2, reversible, 10 bar	0.71 in	VABF-S4-2-R6C2-C-10	546252	
	For port 2, reversible, 10 bar	1.02 in	VABF-S4-1-R6C2-C-10	546251	
	For port 2, reversible, 10 bar	1.65 in ¹⁾	VABF-S2-1-R6C2-C-10	546832	
ZN	For port 2, reversible, 6 bar	0.71 in	VABF-S4-2-R6C2-C-6	546248	
	For port 2, reversible, 6 bar	1.02 in	VABF-S4-1-R6C2-C-6	546247	
	For port 2, reversible, 6 bar	1.65 in ¹⁾	VABF-S2-1-R6C2-C-6	546831	
ZK	For port 4, reversible, 10 bar	0.71 in	VABF-S4-2-R7C2-C-10	546254	
	For port 4, reversible, 10 bar	1.02 in	VABF-S4-1-R7C2-C-10	546253	
	For port 4, reversible, 10 bar	1.65 in ¹⁾	VABF-S2-1-R7C2-C-10	546834	
ZM	For port 4, reversible, 6 bar	0.71 in	VABF-S4-2-R7C2-C-6	546250	
	For port 4, reversible, 6 bar	1.02 in	VABF-S4-1-R7C2-C-6	546249	
	For port 4, reversible, 6 bar	1.65 in ¹⁾	VABF-S2-1-R7C2-C-6	546833	

1) Type 44 VTSA only

Accessories

Valve Manifolds Type 44 VTSA, Type 45 VTSA-F – Inch Series

FESTO

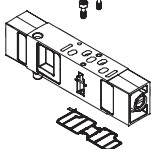
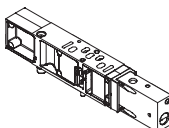
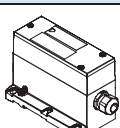
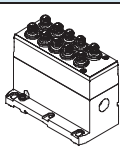
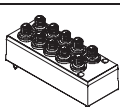
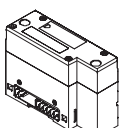
Ordering Data						
Designation	Code	Description	Width	Type	Part No.	
Pressure gauge						
	T	With cartridge connection for regulator, 10 bar for regulator plate, code ZA, ZB, ZC, ZD, ZE	0.71 in	PAGN-26-16-P10	543487	
			1.02 in			
			1.65 in ¹⁾			
	U	With cartridge connection for regulator, 6 bar for regulator plate, code ZF, ZG, ZH, ZI, ZJ	0.71 in	PAGN-26-10-P10	543488	
			1.02 in			
			1.65 in ¹⁾			PAGN-40-10-P10
Cartridge for regulator plate						
	–	For tubing O.D. 0.157 in		QSP10-4	172972	
			For tubing O.D. 0.236 in		QSP10-6	172973
			For tubing O.D. 3/16"		QSP10-3/16U	172975
Flow control plate						
	X	Controls the flow of exhaust air after the valve to ducts 3 and 5	0.71 in	VABF-S4-2-F1B1-C	540176	
			1.02 in	VABF-S4-1-F1B1-C	540175	
			1.65 in ¹⁾	VABF-S2-1-F1B1-C	546095	
Vertical shut-off plate						
	ZT	2/2-way valve for shutting off the operating pressure at the valve position	0.71 in	VABF-S4-2-L1D1-C	542884	
			1.02 in	VABF-S4-1-L1D1-C	542885	
			1.65 in ¹⁾	VABF-S2-1-L1D1-C	546096	
Multi-pin node						
	T	Tension spring, for NPT connection, 36-pin		VABE-S6-1LF-C-M1-C36N	543413	
	MP1	Sub-D plug, 37-pin		VABE-S6-1LT-C-M1-S37	543414	
Individual electrical connection						
	-MP2	Multi-pin node with individual connection M12, 6-way		VABE-S6-LT-C-S6-R5	549046	
	-MP3	Multi-pin node with individual connection M12, 10-way		VABE-S6-LT-C-S10-R5	549047	
	–	Cover for individual connection M12, 6-way		VAEM-S6-C-S6-R5	549048	
	–	Cover for individual connection M12, 10-way		VAEM-S6-C-S10-R5	549049	
Pneumatic interface						
	–	For electrical manifold CPX		VABA-S6-1-X1	543416	

1) Type 44 VTSA only

Accessories







Valve Manifolds Type 44 VTSA, Type 45 VTSA-F – Inch Series

Ordering Data						
Designation	Code	Description		Type	Part No.	
Connecting cable with Sub-D plug socket						
	Polyurethane, IP65					
	GA	Connecting cable for max. 8 solenoid coils, 10-pin, suitable for chain link trunking	8.2 ft	NEBV-S1W37-E-2,5-LE10	539240	
	GB		16.4 ft	NEBV-S1W37-E-5-LE10	539241	
	GC		32.8 ft	NEBV-S1W37-E-10-LE10	539242	
	GD	Connecting cable for max. 22 solenoid coils, 26-pin, suitable for chain link trunking	8.2 ft	NEBV-S1W37-E-2,5-LE26	539243	
	GE		16.4 ft	NEBV-S1W37-E-5-LE26	539244	
	GF		32.8 ft	NEBV-S1W37-E-10-LE26	539245	
	GG	Connecting cable for max. 32 solenoid coils, 37-pin	8.2 ft	NEBV-S1W37-K-2,5-LE37	539246	
	GH		16.4 ft	NEBV-S1W37-K-5-LE37	539247	
	GI		32.8 ft	NEBV-S1W37-K-10-LE37	539248	
	Polyvinyl chloride, IP65					
	GK	Connecting cable for max. 8 solenoid coils, 10-pin	8.2 ft	NEBV-S1W37-KM-2,5-LE10	543271	
	GL		16.4 ft	NEBV-S1W37-KM-5-LE10	543272	
	GM		32.8 ft	NEBV-S1W37-KM-10-LE10	543273	
	GN	Connecting cable for max. 22 solenoid coils, 27-pin	8.2 ft	NEBV-S1W37-KM-2,5-LE27	543274	
	GO		16.4 ft	NEBV-S1W37-KM-5-LE27	543275	
	GP		32.8 ft	NEBV-S1W37-KM-10-LE27	543276	
	GQ	Connecting cable for max. 32 solenoid coils, 37-pin	8.2 ft	NEBV-S1W37-KM-2,5-LE37	543277	
	GR		16.4 ft	NEBV-S1W37-KM-5-LE37	543278	
GS	32.8 ft		NEBV-S1W37-KM-10-LE37	543279		

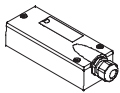
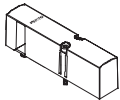
Accessories

Valve Manifolds Type 44 VTSA, Type 45 VTSA-F – Inch Series

FESTO

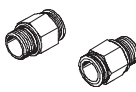
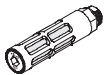
Ordering Data					
Designation	Code	Description	Type	Part No.	
Cover for multi-pin plug					
	–	For user configuration	NECV-S1W37	545974	
Cover					
	L	Blanking plate for vacant position	0.71 in	VABB-S4-2-WT	539213
			1.02 in	VABB-S4-1-WT	539212
			1.65 in	VABB-S2-1-WT	543186
	N	Cover cap for manual override, pushing	10 pieces	VAMC-S6-CH	541010
	V	Cover cap for manual override, covered	10 pieces	VAMC-S6-CS	541011
	–	End cap for electrical manifold module, size 18 mm and 26 mm	10 pieces	VABD-S4-E-C	547713
Inscription label holder					
	B	Clip-on inscription label holder for valve cap	5 pieces	ASCF-T-S6	540888
	T	Inscription label holder for manifold blocks	5 pieces	ASCF-M-S6	540889
Push-in fitting					
	–	Connecting thread 1/4 NPT for tubing O.D. 5/16"	QS-1/4-5/16-U	153609	
		Connecting thread 1/4 NPT for tubing O.D. 1/2"	QS-1/4-1/2-U	190681	
		Connecting thread 1/8 NPT for tubing O.D. 5/16"	QS-1/8-5/16-U	153608	
		Connecting thread 1/8 NPT for tubing O.D. 1/4"	QS-1/8-1/4-U	153605	
		Connecting thread 1/2 NPT for tubing O.D. 1/2"	QS-1/2-1/2-U	153615	
		Connecting thread 1/2 NPT for tubing O.D. 5/8"	QS-1/2-5/8-U	190682	
Silencer					
	–	Connecting thread 1/4 NPT	U-1/4-B-NPT	12639	
	K, L	Connecting thread 1/2 NPT	U-1/2-B-NPT	12741	

Accessories

Valve Manifolds Type 44 VTSA, Type 45 VTSA-F – Inch Series

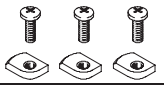
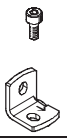
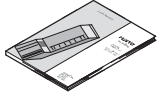

Ordering Data					
Designation	Code	Description	Type	Part No.	
Blanking plug					
	-	Thread 1/8 NPT	1 piece	B-1/8-NPT	173985
	-	Thread 1/4 NPT	1 piece	B-1/4-NPT	174165
DIN H-rail mounting					
	-	VTSA/VTSA-F with fieldbus	3 pieces	CPX-CPA-BG-NRH	526032
	-	VTSA/VTSA-F with multi-pin plug	2 pieces	CPA-BG-NRH	173498
Wall mounting					
	U	Mounting bracket		VAME-S6-10-W	539214
User manual					
	D	User manual for valve manifold VTSA/VTSA-F	German	P.BE-VTSA-44-DE	538922
	E		English	P.BE-VTSA-44-EN	538923
	S		Spanish	P.BE-VTSA-44-ES	538924
	F		French	P.BE-VTSA-44-FR	538925
	I		Italian	P.BE-VTSA-44-IT	538926
	V		Swedish	P.BE-VTSA-44-SV	538927

Product Range and Company Overview

A Complete Suite of Automation Services

Our experienced engineers provide complete support at every stage of your development process, including: conceptualization, analysis, engineering, design, assembly, documentation, validation, and production.



Custom Automation Components
Complete custom engineered solutions



Custom Control Cabinets
Comprehensive engineering support and on-site services



Complete Systems
Shipment, stocking and storage services

The Broadest Range of Automation Components

With a comprehensive line of more than 30,000 automation components, Festo is capable of solving the most complex automation requirements.



Electromechanical
Electromechanical actuators, motors, controllers & drives



Pneumatics
Pneumatic linear and rotary actuators, valves, and air supply



PLCs and I/O Devices
PLC's, operator interfaces, sensors and I/O devices

Supporting Advanced Automation... As No One Else Can!

Festo is a leading global manufacturer of pneumatic and electromechanical systems, components and controls for industrial automation, with more than 12,000 employees in 56 national headquarters serving more than 180 countries. For more than 80 years, Festo has continuously elevated the state of manufacturing with innovations and optimized motion control solutions that deliver higher performing, more profitable automated manufacturing and processing equipment. Our dedication to the advancement of automation extends beyond technology to the education and development of current and future automation and robotics designers with simulation tools, teaching programs, and on-site services.

Quality Assurance, ISO 9001 and ISO 14001 Certifications

Festo Corporation is committed to supply all Festo products and services that will meet or exceed our customers' requirements in product quality, delivery, customer service and satisfaction.

To meet this commitment, we strive to ensure a consistent, integrated, and systematic approach to management that will meet or exceed the requirements of the ISO 9001 standard for Quality Management and the ISO 14001 standard for Environmental Management.



© Copyright 2008, Festo Corporation. While every effort is made to ensure that all dimensions and specifications are correct, Festo cannot guarantee that publications are completely free of any error, in particular typing or printing errors. Accordingly, Festo cannot be held responsible for the same. For Liability and Warranty conditions, refer to our "Terms and Conditions of Sale", available from your local Festo office. All rights reserved. No part of this publication may be reproduced, distributed, or transmitted in any form or by any means, electronic, mechanical, photocopying or otherwise, without the prior written permission of Festo. All technical data subject to change according to technical update.



Printed on recycled paper at New Horizon Graphic, Inc., FSC certified as an environmentally friendly printing plant.

Festo North America

United States

Customer Resource Center

502 Earth City Expy., Suite 125
Earth City, MO 63045

For ordering assistance, or to find
your nearest Festo Distributor,

Call: 1.800.99.FESTO

Fax: 1.800.96.FESTO

Email: customer.service@us.festo.com

For technical support,

Call: 1.866.GO.FESTO

Fax: 1.800.96.FESTO

Email: product.support@us.festo.com

Headquarters

Festo Corporation
395 Moreland Road
P.O. Box 18023
Hauppauge, NY 11788
www.festo.com/us

Sales Offices

Appleton

N. 922 Tower View Drive, Suite N
Greenville, WI 54942

Boston

120 Presidential Way, Suite 330
Woburn, MA 01801

Chicago

1441 East Business Center Drive
Mt. Prospect, IL 60056

Dallas

1825 Lakeway Drive, Suite 600
Lewisville, TX 75057

Detroit - Automotive Engineering Center

2601 Cambridge Court, Suite 320
Auburn Hills, MI 48326

New York

395 Moreland Road
Hauppauge, NY 11788

Silicon Valley

4935 Southfront Road, Suite F
Livermore, CA 94550

Design and Manufacturing Operations



East: 395 Moreland Road, Hauppauge, NY 11788



Central: 1441 East Business Center Drive, Mt. Prospect, IL 60056



West: 4935 Southfront Road, Suite F, Livermore, CA 94550

Mexico

Headquarters

Festo Pneumatic, S.A.
Av. Ceylán 3, Col. Tequesquahuac
54020 Tlalnepantla, Edo. de México
Call: 011 52 [55] 53 21 66 00
Fax: 011 52 [55] 53 21 66 65
Email: festo.mexico@mx.festo.com
www.festo.com/mx



Canada

Headquarters

Festo Inc.
5300 Explorer Drive
Mississauga, Ontario L4W 5G4
Call: 1.905.624.9000
Fax: 1.905.624.9001
Email: info.ca@ca.festo.com
www.festo.com/ca



Festo Worldwide

Argentina Australia Austria Belarus Belgium Brazil Bulgaria Canada Chile China Colombia Croatia Czech Republic Denmark
Estonia Finland France Germany Great Britain Greece Hong Kong Hungary India Indonesia Iran Ireland Israel Italy Japan
Latvia Lithuania Malaysia Mexico Netherlands New Zealand Norway Peru Philippines Poland Romania Russia Serbia Singapore
Slovakia Slovenia South Africa South Korea Spain Sweden Switzerland Taiwan Thailand Turkey Ukraine United States Venezuela

www.festo.com