

San Ace 100W

9W2TM type

Splash Proof Centrifugal Fan

Features

Water and Dust Protection

Its IP68-rated⁽¹⁾ water and dust protection, which is improved compared with that of our current model, ensures stable fan operation even in harsh environments.⁽²⁾

High Airflow and High Static Pressure

This fan delivers a maximum airflow of 2.03 m³/min and a maximum static pressure of 708 Pa.⁽³⁾

Low Noise and High Energy Efficiency

The PWM control function enables the control of fan speed, contributing to lowering noise and improving energy efficiency of devices.

(1) The degree of protection (IP code) is defined by IEC 60529 (International Electrotechnical Commission) as follows.

(2) Current model: *San Ace 100W 9W2TM type* *100 x 25 mm Splash Proof Centrifugal Fan

(3) For models 9W2TM24P4G001 and 9W2TM48P4G001



∅100 x 25 mm

Specifications

When the optional inlet nozzle (109-1080H) is mounted.

The models listed below **have pulse sensors with PWM control function.**

Model no.	Rated voltage [V]	Operating voltage range [V]	PWM duty cycle* [%]	Rated current [A]	Rated input [W]	Rated speed [min ⁻¹]	Max. airflow [m ³ /min] [CFM]	Max. static pressure [Pa] [inchH ₂ O]	SPL [dB(A)]	Operating temperature [°C]	Expected life [h]
9W2TM24P4G001	24	18 to 27.6	100	0.7	16.8	7400	2.03 71.7	708 2.84	65	-20 to +70	40000/60°C (70000/40°C)
			20	0.04	0.96	1500	0.39 14	30 0.12	31		
9W2TM24P4H001			100	0.44	10.56	6400	1.77 62.5	560 2.25	60		
			20	0.04	0.96	1500	0.39 14	30 0.12	31		
9W2TM48P4G001	48	36 to 60	100	0.35	16.8	7400	2.03 71.7	708 2.84	65		
			20	0.04	1.92	1500	0.39 14	30 0.12	31		
9W2TM48P4H001			100	0.22	10.56	6400	1.77 62.5	560 2.25	60		
			20	0.04	1.92	1500	0.39 14	30 0.12	31		

* PWM input frequency is 25 kHz; models without specifications at 0% PWM duty cycle have zero fan speed at 0%.

Common Specifications

- Material Motor case: Aluminum (Black coating), Impeller: Plastic (Flammability: UL 94V-0)
- Expected life Refer to specifications
(L10 life: 90% survival rate for continuous operation in indoor free air at 60°C, rated voltage)
Expected life at 40°C is for reference only.
- Motor protection function Locked rotor burnout protection, Reverse polarity protection
- Dielectric strength 50/60 Hz, 500 VAC, for 1 minute (between lead wire conductors and motor case)
- Insulation resistance 10 MΩ or more with a 500 VDC megger (between lead wire conductors and motor case)
- Sound pressure level (SPL) At 1 m away from the air inlet
- Operating temperature Refer to specifications (Non-condensing)
- Storage temperature -30 to +70°C (Non-condensing)
- Lead wire ⊕ Red ⊖ Black Sensor Yellow Control Brown
- Mass 190 g
- Ingress protection IP68

Airflow - Static Pressure Characteristics

• PWM duty cycle

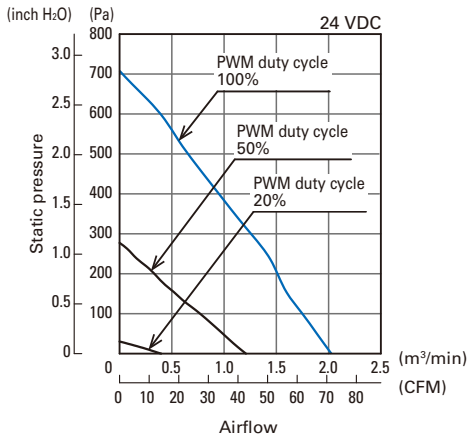

9W2TM24P4G001

• Operating voltage range

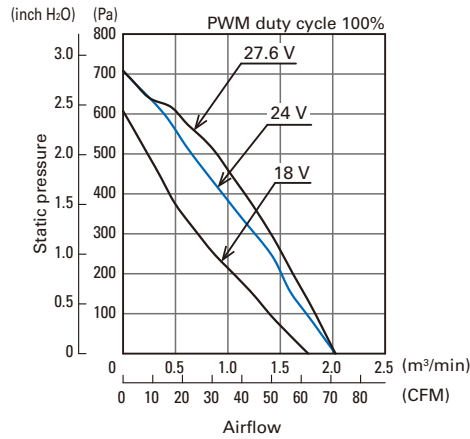

9W2TM24P4G001

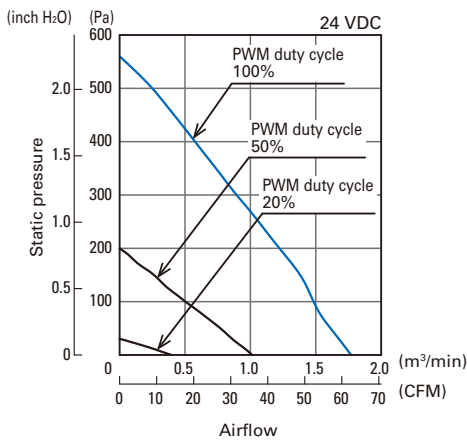

9W2TM24P4H001

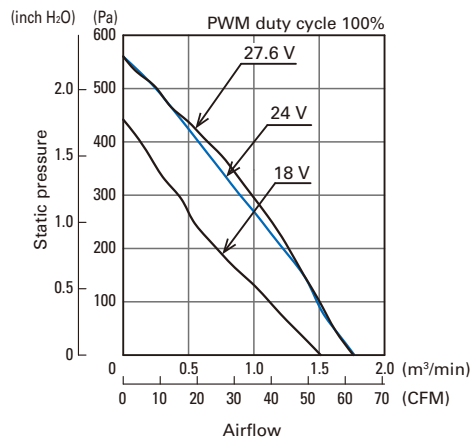

9W2TM24P4H001

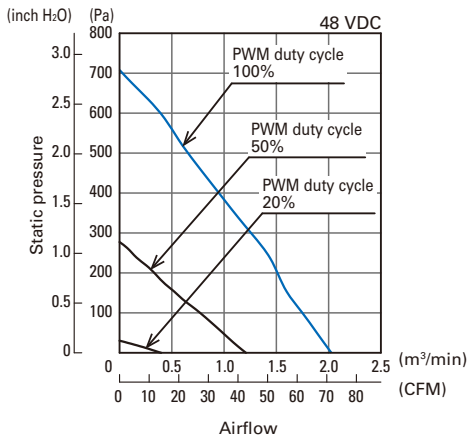

9W2TM48P4G001

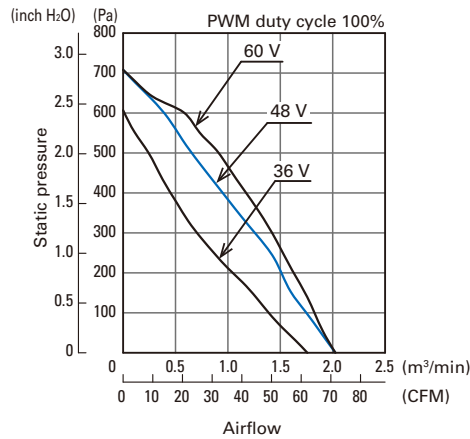

9W2TM48P4G001

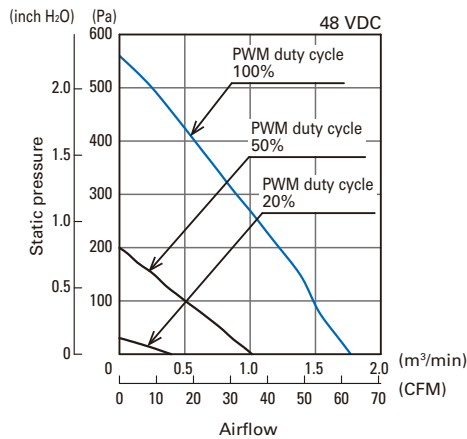

9W2TM48P4H001

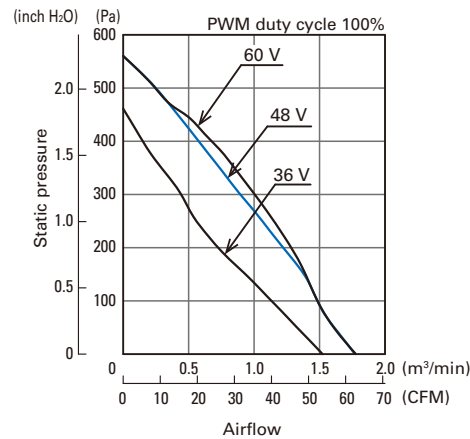

9W2TM48P4H001

PWM Duty - Speed Characteristics Example

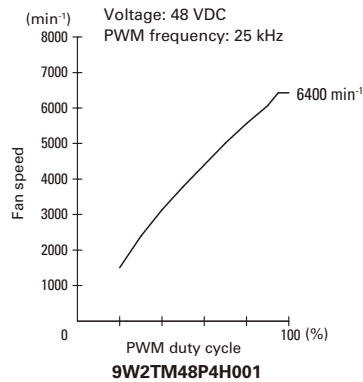
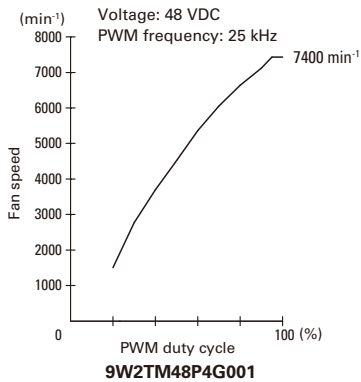
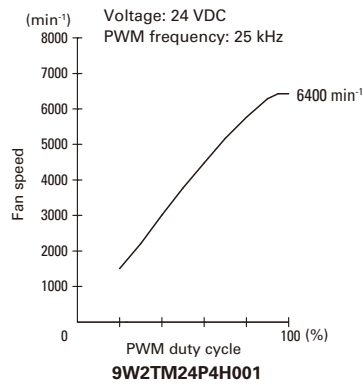
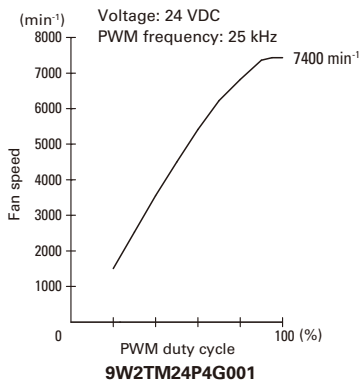

PWM Input Signal Example

Input signal waveform

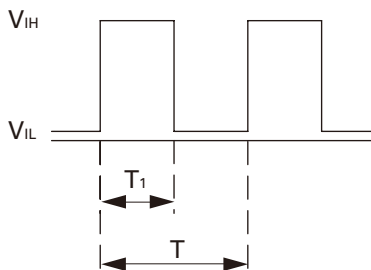

$V_{IH} = 4.75 \text{ to } 5.25 \text{ V}$ $V_{IL} = 0 \text{ to } 0.4 \text{ V}$

PWM duty cycle (%) = $\frac{T_1}{T} \times 100$ PWM frequency 25 (kHz) = $\frac{1}{T}$

Current source (I_{source}) = 1 mA max. (when control voltage is 0 V)

Current sink (I_{sink}) = 1 mA max. (when control voltage is 5.25 V)

Control terminal voltage = 5.25 V max. (when control terminal is open)

When the PWM control terminal is open,

the fan speed is the same as the speed at 100% PWM duty cycle.

Either a TTL input or open collector/drain input can be used for the PWM input signal.

Example of Connection Schematic

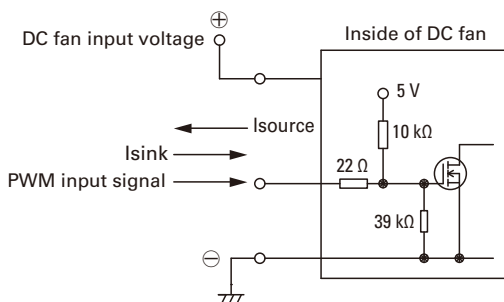

Specifications for Pulse Sensors

Output circuit: Open collector

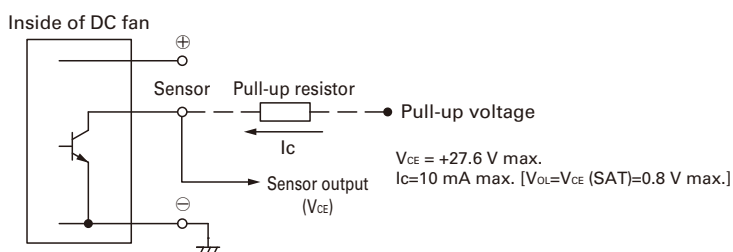

Output waveform (Need pull-up resistor)

In case of steady running

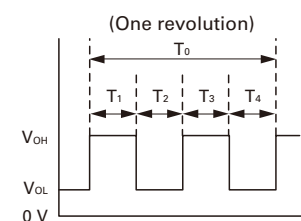

$T_{1 \text{ to } 4} \doteq (1/4) T_0$

$T_{1 \text{ to } 4} \doteq (1/4) T_0 = 60/4N \text{ (s)}$

$N = \text{Fan speed (min}^{-1}\text{)}$

Dimensions (unit: mm)

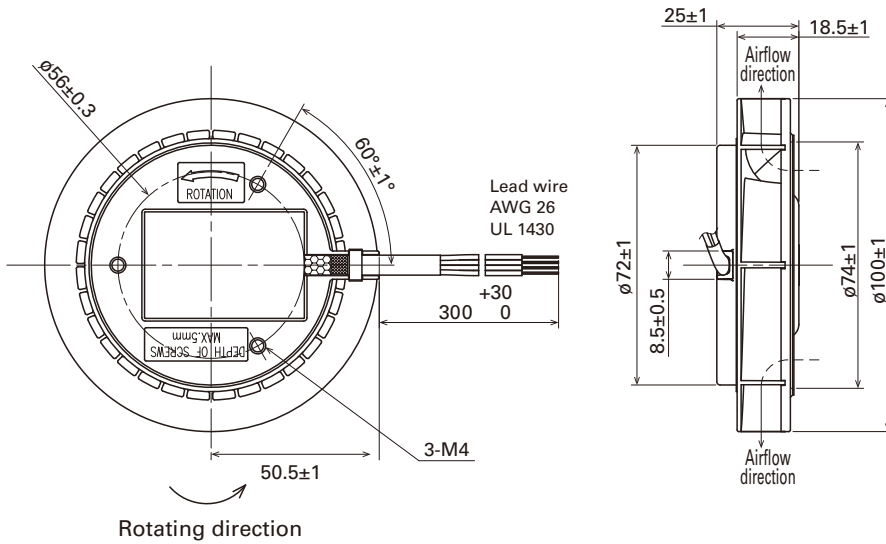

Reference Dimensions of Mounting Holes and Vent Opening (unit: mm)

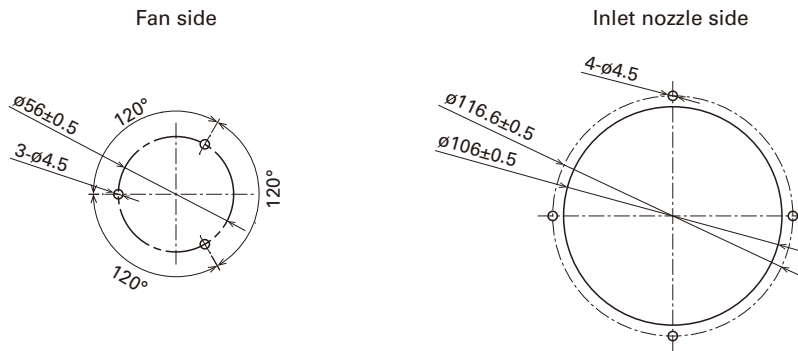

Reference Diagram for Mounting (unit: mm)

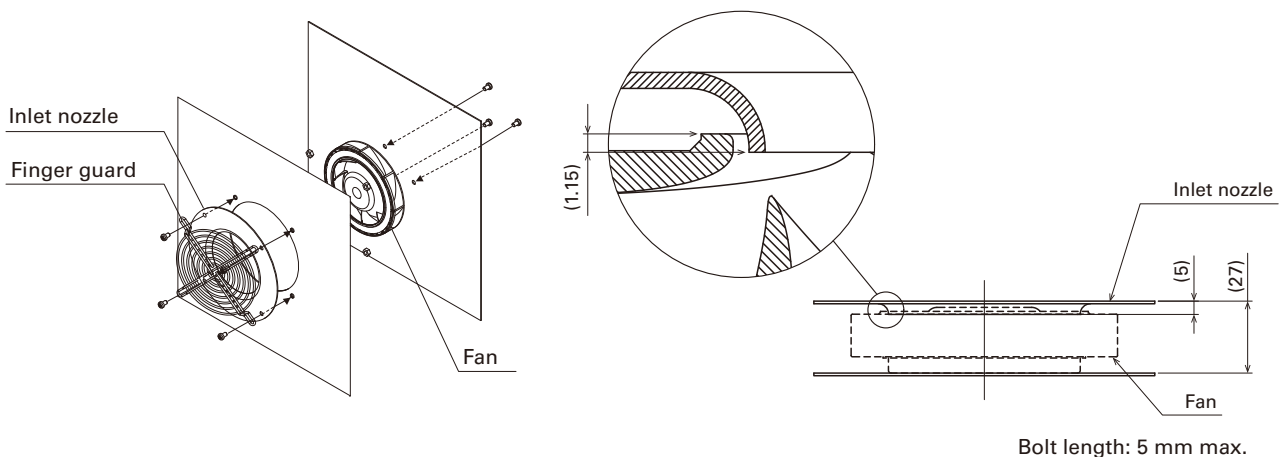

Notice

- Please read the "Safety Precautions" on our website before using the product.
- The products shown in this catalog are subject to Japanese Export Control Law. Diversion contrary to the law of exporting country is prohibited.
- For protecting fan bearings against electrolytic corrosion near strong electromagnetic noise sources, we provide effective countermeasures such as Electrolytic Corrosion Proof Fans and EMC guards. Contact us for details.

SANYO DENKI CO., LTD. 3-33-1 Minami-Otsuka, Toshima-ku, Tokyo 170-8451, Japan TEL: +81 3 5927 1020

<https://www.sanyodenki.com/>

The names of companies and/or their products specified in this catalog are the trade names, and/or trademarks and/or registered trademarks of such respective companies.

"San Ace" is a trademark of SANYO DENKI CO., LTD.

Specifications are subject to change without notice.

CATALOG No. C1117B001 '21.7