

## Insulation Resistance Monitoring Device

# K7GE-MG

### Reliable, Safe and Accurate Automatic Insulation Resistance Measurements



- Measures insulation resistance automatically when a trigger signal is input
- Identifies the trend in insulation deterioration from the measurement data collected via communications
- Conducts measurements safely with a Megger voltage of 50 VDC
- Able to measure up to eight points simultaneously
- Constantly monitors the voltage applied to the device targeted for measurement, and automatically stops measurement if the target device power is turned ON after measurement has started



**NEW**

Refer to your OMRON website for the most recent information on applicable safety standards.

### Overview

The K7GE-MG is a device that automatically measures the insulation resistance of a load and supports trend monitoring. Periodic inspections by manpower may cause an unexpected machine stoppage due to a decrease in insulation resistance of equipment before the next inspection. The K7GE-MG provides automatic monitoring of the insulation resistance of each load and allows planned maintenance.

The K7GE-MG measures the insulation resistance by the same detection principle (Megger method) as a Megohmmeter.

To measure the insulation resistance using the K7GE-MG, it is necessary to combine one Main Unit with at least one Probe Unit.

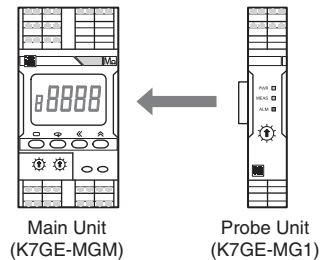

The functions of the Main Unit and Probe Unit are shown in the figure on the right. The Main Unit correspond to a Megohmmeter, and the Probe Unit correspond to a measurement probe with internal contacts. The Main Unit turns ON these contacts in sequence and measure multiple loads individually. Up to eight Probe Units can be connected to one Main Unit.

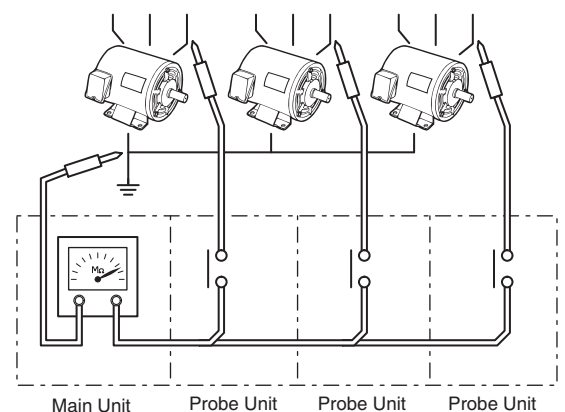

# K7GE-MG

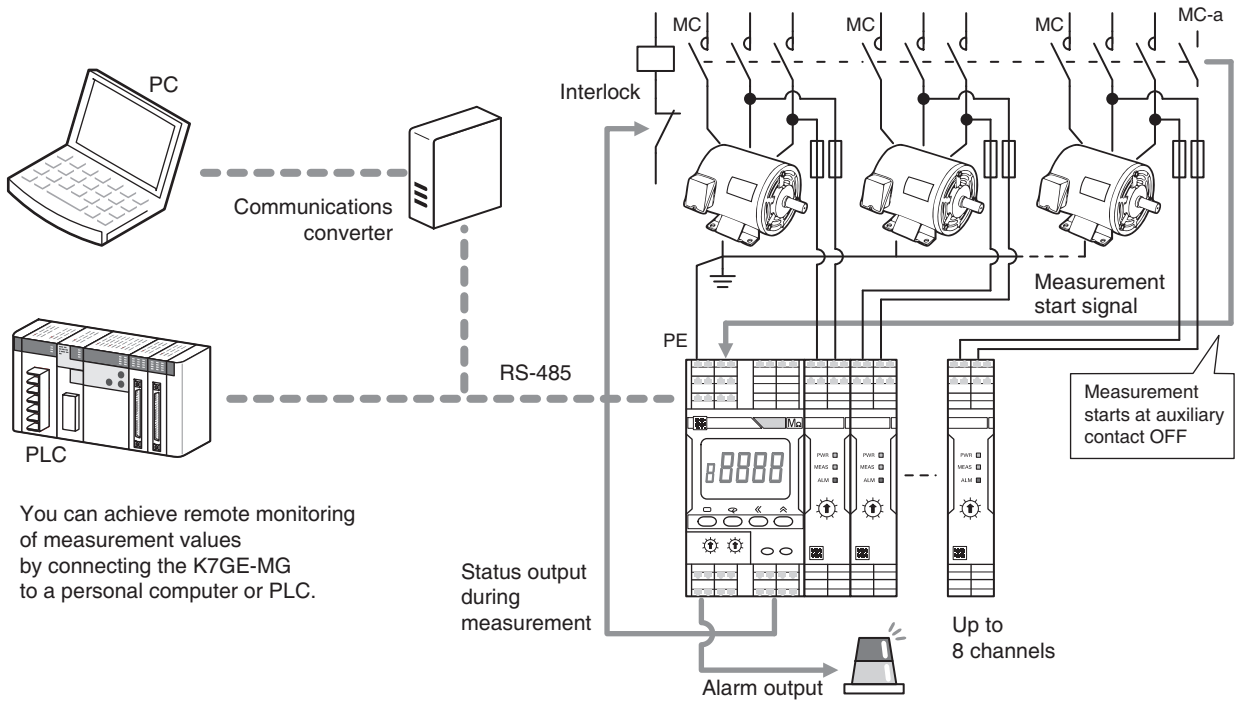

## System Configuration



## Ordering Information

Unit	Power supply voltage	Model
Main Unit	100 to 240 VAC	<b>K7GE-MGMA</b>
	24 VAC/VDC	<b>K7GE-MGMD</b>
Probe Unit	---	<b>K7GE-MG1</b>

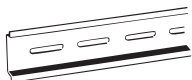
## Accessories (Order Separately)

DIN Tracks	Model
	<b>PFP-100N</b>
	<b>PFP-50N</b>
End Plate	Model
	<b>PFP-M</b>

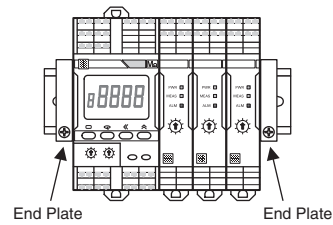

End Plates must be mounted at both ends to prevent contact failure between the Units due to vibration and shock.

## Ratings and Specifications

Item	Specifications	
Power supply voltage and frequency	K7GE-MGMA: 100 to 240 VAC, 50/60 Hz K7GE-MGMD: 24 VAC, 50/60 Hz, 24 VDC	
Operating voltage range	85% to 110% of the rated voltage	
Operating frequency range	45 to 65 Hz	
Power consumption	Maximum Unit configuration: one Main Unit and eight Probe Units 12.9 VA max. (100 to 240 VAC)/7.8 VA max. (24 VAC)/4.7 W max. (24 VDC) Minimum Unit configuration: one Main Unit and one Probe Unit 8.4 VA max. (100 to 240 VAC)/4.6 VA max. (24 VAC)/2.5 W max. (24 VDC)	
Ambient operating temperature	-10 to 55°C (with no condensation or icing)	
Ambient operating humidity	25% to 85% (with no condensation)	
Storage temperature	-20 to 65°C	
Altitude	2,000 m max.	
Recommended fuse	T2A, time delay, high-breaking capacity (for Main Unit operating power supply) Tripping current: 7 A max., fast-blow (for Probe Unit voltage input)	
Insulation resistance	20 MΩ min. Between all external terminals and the case, between all power supply terminals and all other terminals, between PE terminal, and trigger input terminal, all communications terminals and all transistor output terminals 1,000 MΩ min. Between Probe Unit voltage monitoring terminal and PE terminal	
Dielectric strength	2,000 VAC for 1 minute Between all external terminals and the case, between all power supply terminals and all other terminals, between PE terminal, and trigger input terminal, all communications terminals and all transistor output terminals 1,000 VDC for 1 minute Between Probe Unit voltage monitoring terminal and PE terminal	
Vibration resistance	Frequency: 10 to 55 Hz, 0.35-mm single amplitude, acceleration 50 m/s <sup>2</sup> , 10 sweeps of 5 min each in X, Y, and Z directions	
Shock resistance	100 m/s <sup>2</sup> , 3 times each in X, Y, and Z axes, 6 directions	
Degree of protection	IP20	
Terminal block type	Push-In Plus	
Exterior color	Black (Munsell N 1.5)	
Mounting	DIN Track mounting	
Weight	Main Unit: Approx. 156 g Probe Unit: Approx. 63 g	
Installation environment	Operation power supply: EN/IEC 61010-1 Over-voltage category II Pollution degree 2 Measurement circuit: EN/IEC 61010-2-030 Pollution degree 2 For details about the measurement category, refer to <i>Conformance to Safety Standards</i> on page 14.	
Electromagnetic environment	EN/IEC 61326-1 Industrial electromagnetic environment	
Safety standards	UL 61010-1 Korean Radio Waves Act (KN 61000-6-2 and KN 11) RCM	
Wiring material	Wire type	Solid wire or stranded wire
	Wiring material	Copper
	Recommended wire	0.25 to 1.5 mm <sup>2</sup> AWG 24 to AWG 16
	Stripping length Without ferrules	8 mm

# K7GE-MG

## Measurement Specifications

Item	Specifications
Measurement range	0.1 to 99.9 MΩ (0.0 MΩ for less than 0.1 MΩ)
Measuring accuracy	±5% rdg. ±1 digit (at ambient temperature -10 to 55°C and ambient humidity 25% to 65%)
Megger voltage	50 VDC
Measurement operation	Perform one measurement operation for each trigger. One-shot trigger.
Average count	Disabled (1 time)/Enabled (8 times)
Measurement target	Single-phase/3-phase AC induction motors An inverter-driven motor requires a contactor on the secondary coil of the inverter. Similarly, a servo motor requires a contactor on the secondary coil of the Servo Drive. A motor with a star delta starter requires a delta connection or a star connection for measurement. Also able to measure DC motors.

## Input Specifications of Trigger Input Terminals

Item	Specifications
Input type	No-voltage contact and open collector are possible.
Residual voltage at short circuit	1.5 V max.
Open leakage current	0.1 mA max.
ON current at short circuit	Approx. 7 mA
Minimum detection time	Received as a valid continuous input for at least 50 ms for both ON and OFF.

## Output Specifications of Transistor Output Terminals

Item	Specifications
Contact form	NPN open collector
Rated voltage	24 VDC (maximum voltage: 26.4 VDC)
Maximum current	50 mA
Leakage current when power turning OFF	0.1 mA max.
Residual voltage	1.5 V max.

## Input Specifications of Voltage Input Terminals

Item	Specifications
System voltage (All are specified as line voltage)	AC waveform: <Single-phase, 2-wire, N-phase ground> Sine waveform: 100 to 600 VAC, -15% to 10%, 50/60±5 Hz Thyristor waveform: 100 to 600 VAC, -15% to 10%, 50/60±5 Hz (0° to 150° dia.) Inverter waveform: 100 to 600 VAC, -15% to 10%, 20 to 85 Hz <3-phase, 3-wire, S-phase ground> Sine waveform: 100 to 480 VAC, -15% to 10%, 50/60±5 Hz Thyristor waveform: 100 to 480 VAC, -15% to 10%, 50/60±5 Hz (0° to 150° dia.) Inverter waveform: 100 to 480 VAC, -15% to 10%, 20 to 85 Hz <3-phase, 4-wire, N-phase ground> Sine waveform: 100 to 600 VAC, -15% to 10%, 50/60±5 Hz Thyristor waveform: 100 to 600 VAC, -15% to 10%, 50/60±5 Hz (0° to 150° dia.) Inverter waveform: 100 to 600 VAC, -15% to 10%, 20 to 85 Hz DC waveform: 24 to 480 VDC, -15% to 10%

## Communications Specifications

Item	Specifications
Physical layer	RS-485
Transmission path connection method	RS-485: Multidrop
Communications method	RS-485 (2-wire, half duplex)
Synchronization method	Asynchronous
Connection configurations	Master and Slave configurations are 1:1 or 1:N connections.
Maximum number of Units	32 (including one host system)
Cable length	Total 500 m max. (twisted-pair cable)
Baud rate	9.6, 19.2, 38.4 or 57.6 kbps
Data length	7/8 bits
Stop bits	1/2 bits
Error detection	Vertical parity (none/even/odd) BCC (with CompoWay/F selected), CRC-16 (with Modbus RTU selected)
Flow control	None
Retry function	None
Buffer	97 bytes
Send wait time	0 to 99 ms
Protocol	CompoWay/F and Modbus RTU

# K7GE-MG

## Nomenclature

### Front Section

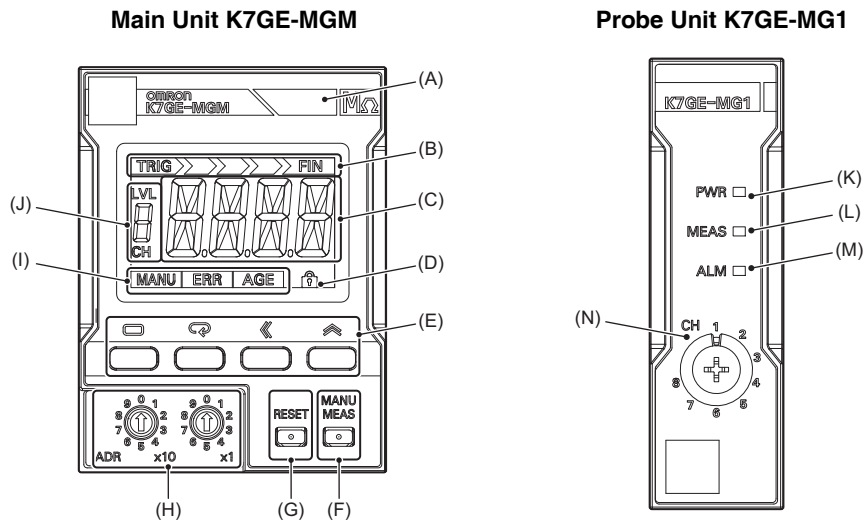

Symbol	Name	Operation
(A)	Alarm output indicator	Displays the alarm judgment results of automatic measurement in three colors. Green: Normal, Yellow: Warning (Alarm 1 occurrence), Red: Critical (Alarm 2 occurrence) If the status is different across multiple channels, the display color is decided in the priority order of red (critical) > yellow (warning) > green (normal).
(B)	Measurement step indicator	The automatic measurement operation consists of several steps. This indicator shows the progress of the step from the start to the end of the measurement.
(C)	Main display	The following contents are displayed in the operating status of the Main Unit. Measuring operation: The remaining seconds until the measurement completes are counted down After measurement completed: The insulation resistance measurement value, or characters indicating measurement failure Setting level: The setting parameter name, or setting value Error occurs: The characters indicating the error status
(D)	Protect indicator	Indicates that the protect function of the setting parameter is set.
(E)	Operation keys	Level Key (□): Selects the setting level. Mode Key (↻): Selects the setting parameter of the Initial Setting Level and Communications Setting Level. Displays the measurement value of each channel at the Operation Level. Also used to select between enabling/disabling of measurement value display automatic scroll. Shift Key (⏪): Sets the parameter value to a changeable state. Used for digit shift in the changeable state. Up Key (⏴): Increments the value when the parameter is in a changeable state.
(F)	Manual Measurement Key	Selects to start or end manual measurement. Manual measurement is used to check the operation when the system is started up. Automatic measurement requires a trigger signal to start measurement, but manual measurement does not require a trigger signal. You can use manual measurement in the same way as a Megohmmeter.
(G)	Reset Key	Selects to return to the power reset status. Even if the measuring operation is in progress, priority is given to the Reset Key, and measurement stops to return to the power reset status. The Reset Key is enabled only in the Operation Level.
(H)	Unit Number Setting Switch	Sets the unit number during communications.
(I)	Status display	MANU: Indicates the manual measurement state. ERR: Indicates that a system error occurred. AGE: Indicates that it is time to replace the Main Unit (guideline).
(J)	LVL/CH display	Displays the level, or the value of the channel number. LVL: Indicates that the value displayed in the LVL/CH display is the "Level". CH: Indicates that the value displayed in the LVL/CH display is the "Channel".
(K)	PWR indicator (green)	Indicates that the Probe Unit power is ON.
(L)	MEAS indicator (green)	Indicates that measurement is in progress for the load connected to the Probe Unit.
(M)	ALM indicator (red)	Indicates that an alarm occurred in the load connected to the Probe Unit.
(N)	Channel Number Setting Switch	Sets a unique channel number for each Unit when multiple Probe Units are added.

## Terminal Section

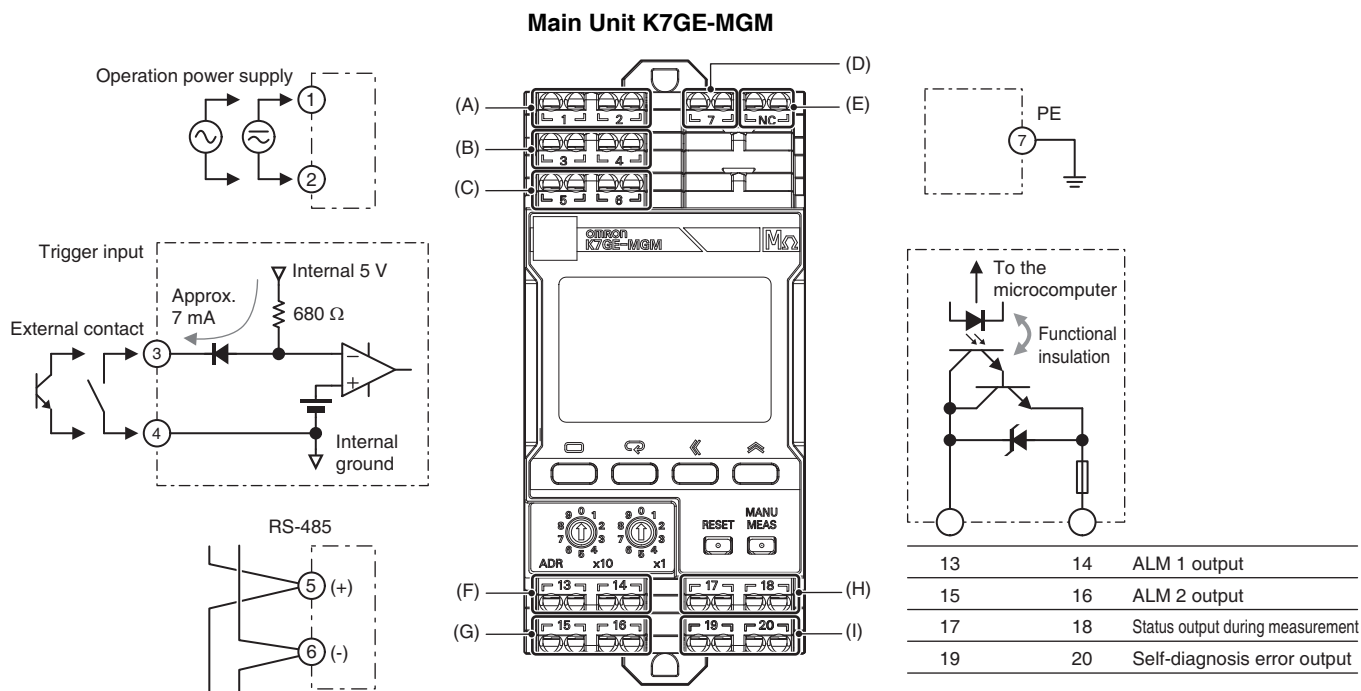

Symbol	Terminal Number	Name	Operation
(A)	1 and 2	Operation power supply	Connect the operation power supply to the Main Unit.
(B)	3 and 4	Trigger input	Input terminals of the external contact from where a trigger signal is applied. No. 3: Collector of the NPN transistor, No. 4: Emitter of the NPN transistor
(C)	5 and 6	RS-485	Connect the RS-485 communications line. No. 5: +, No. 6: -
(D)	7	PE	A protective earthing terminal.
(E)	NC	NC	Do not connect anything to this terminal.
(F)	13 and 14	ALM 1 output	Compares the measurement value and alarm value 1, and outputs an alarm. No. 13: Collector of the NPN transistor, No. 14: Emitter of the NPN transistor
(G)	15 and 16	ALM 2 output	Compares the measurement value and alarm value 2, and outputs an alarm. No. 15: Collector of the NPN transistor, No. 16: Emitter of the NPN transistor
(H)	17 and 18	Status output during measurement	Provides notification that measurement is in progress. The output is normally open (OFF). You can use this output to design an interlock circuit to prevent accidental restart of the load during measurement operation. No. 17: Collector of the NPN transistor, No. 18: Emitter of the NPN transistor
(I)	19 and 20	Self-diagnosis error output	Provides notification about system error in the Main Unit. The output is normally closed (ON). No. 19: Collector of the NPN transistor, No. 20: Emitter of the NPN transistor

## Terminal Section

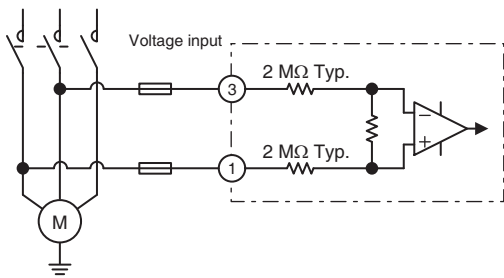

Probe Unit K7GE-MG1

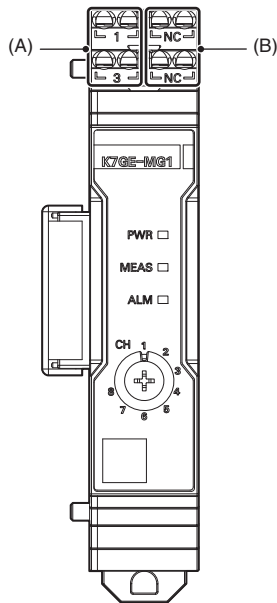

Symbol	Terminal Number	Name	Operation
(A)	1 and 3	Voltage input	Connect the load terminals. No. 1: Connect the R-phase in a 3-phase system, and the L-phase in a single-phase system No. 3: Connect the S-phase in a 3-phase system, and the N-phase in a single-phase system Use the No. 1 terminal to discharge the electric charge and apply the Megger voltage.
(B)	NC	NC	Do not connect anything to this terminal.

## Connection Diagram

### When the Load Is a Single-Phase/3-Phase Induction Motor (Direct Connection to Commercial Power Supply)

Install a contactor between the power line and the motor.

 Do not connect any other device such as a transformer or a filter between the contactor and the motor. Doing so may cause incorrect measurement.

Connect the voltage input of the Probe Unit of the K7GE-MG to the secondary output terminal (motor side) of the contactor.

 Make sure that it is not connected to the primary side (power supply side). It cannot be measured correctly and may cause a hazardous condition.

The figure shows a simplified view of the wiring for status output during measurement, and ALM 1 and ALM 2 outputs. Use an appropriate relay for relaying in consideration of the switching capacity of the output transistor. The specifications of the output transistor for the K7GE-MG are 24 VDC (+10%), 50 mA max.

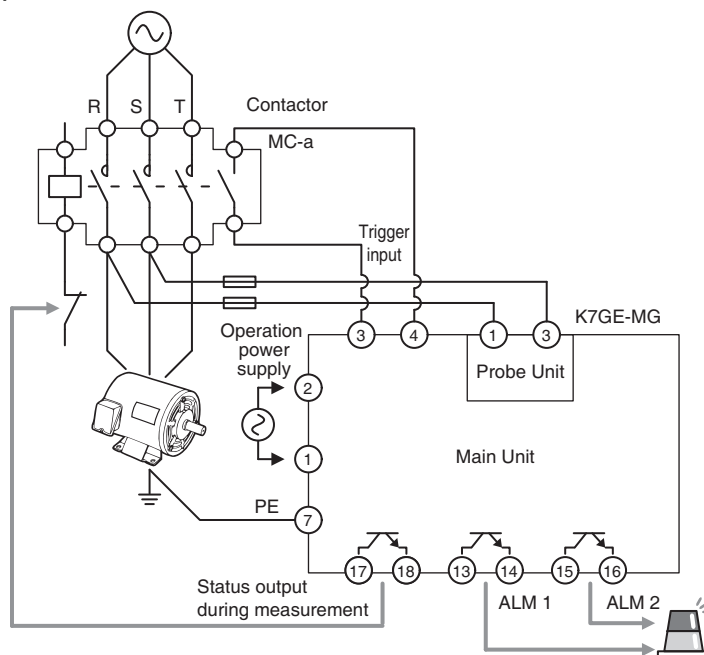

### When the Load Is an Inverter-Driven Motor

Install a contactor between the inverter output and the motor. If a noise filter is to be inserted at the output side of the inverter, insert it between the inverter output and the primary output terminal of the contactor.

 Do not connect any other device such as a transformer or a filter between the contactor and the motor. Doing so may cause incorrect measurement.

Connect the voltage input of the Probe Unit of the K7GE-MG to the secondary output terminal (motor side) of the contactor.

 Make sure that it is not connected to the primary side (power supply side). It cannot be measured correctly and may cause a hazardous condition.

The figure shows a simplified view of the wiring for status output during measurement, and ALM 1 and ALM 2 outputs. Use an appropriate relay for relaying in consideration of the switching capacity of the output transistor. The specifications of the output transistor for the K7GE-MG are 24 VDC (+10%), 50 mA max.

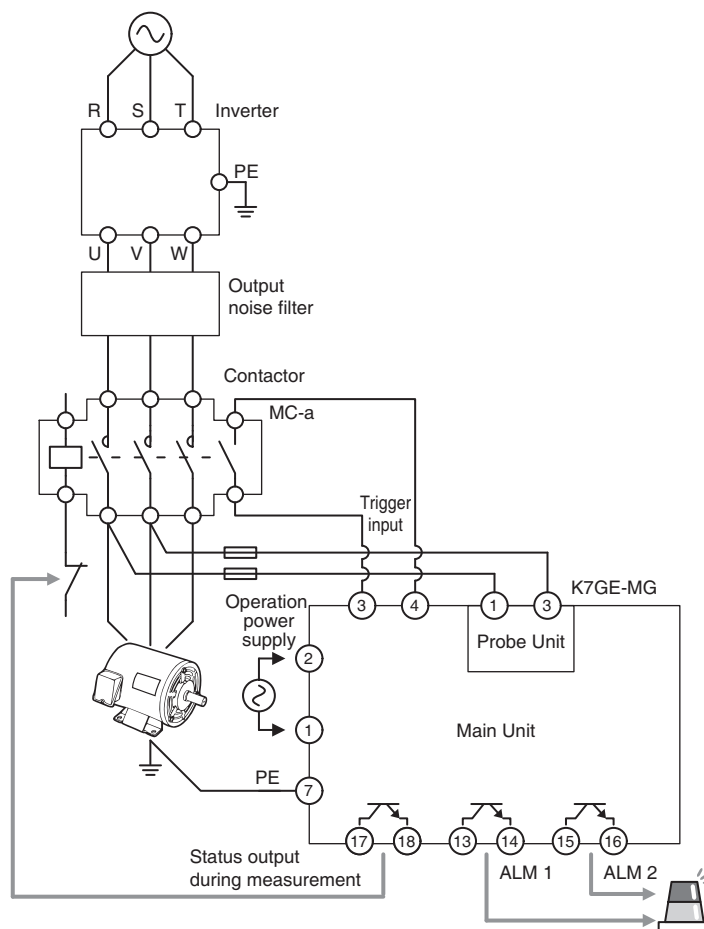

## When the Load Is a Servo Motor

Install a contactor between the Servo Drive output and the motor.

The contactor is required only in the power line. Relays the motor power cables other than the power line to the terminal blocks and connect it to the Servo Drive directly.

Connect the voltage input of the Probe Unit of the K7GE-MG to the secondary output terminal (motor side) of the contactor.

Turn the contactor ON and OFF when the Servo Drive power is OFF.



Do not connect any other device such as a transformer or a filter between the contactor and the motor. Doing so may cause incorrect measurement.



Make sure that it is not connected to the primary side (power supply side). It cannot be measured correctly and may cause a hazardous condition.



If the contactor is turned OFF while the Servo Drive is turned ON, the rotating shaft of the motor will be in a free. If the contactor is turned on after that, the motor may perform unintended operation and can be dangerous.

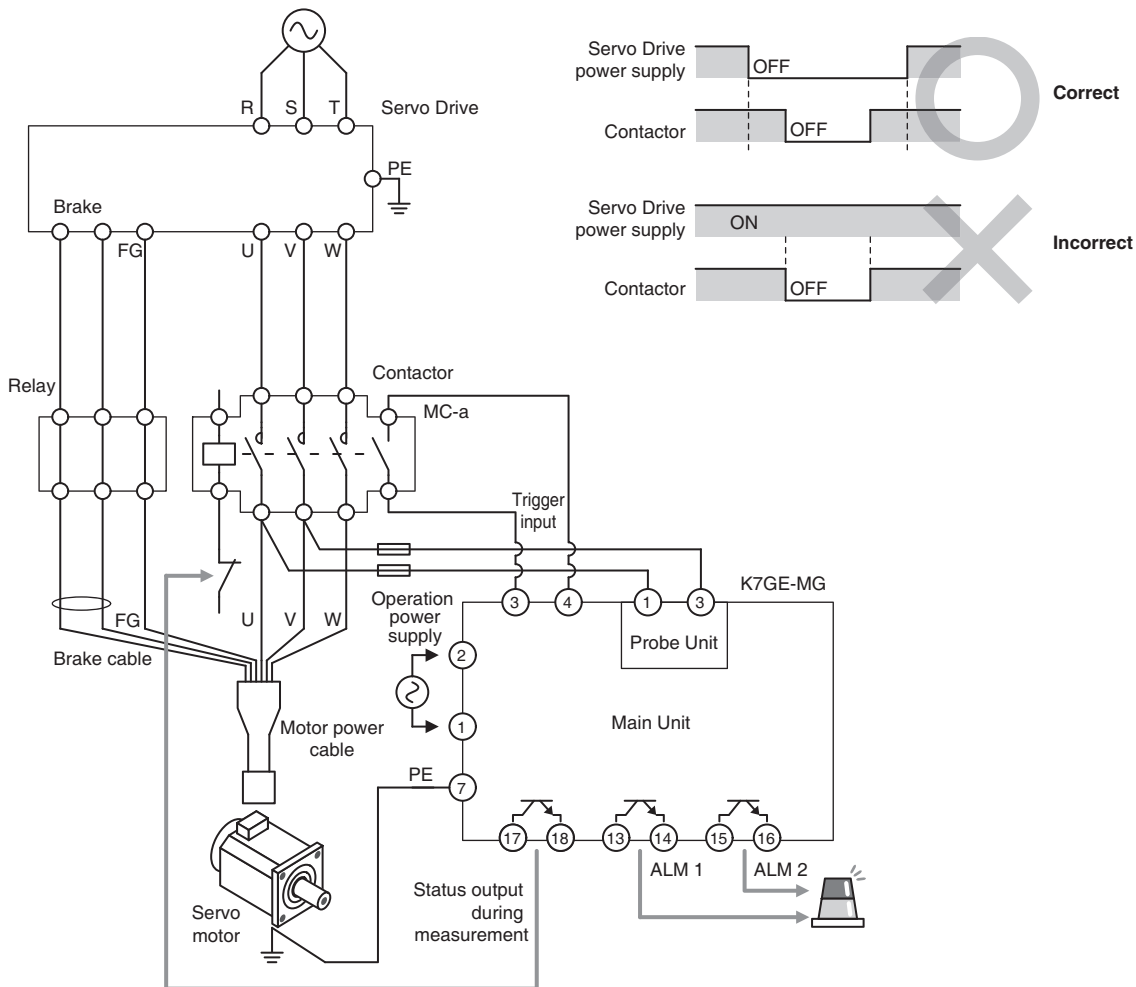

The figure shows a simplified view of the wiring for status output during measurement, and ALM 1 and ALM 2 outputs. Use an appropriate relay for relaying in consideration of the switching capacity of the output transistor. The specifications of the output transistor for the K7GE-MG are 24 VDC (+10%), 50 mA max.

Dimensions

(Unit: mm)

Main Unit  
K7GE-MGM

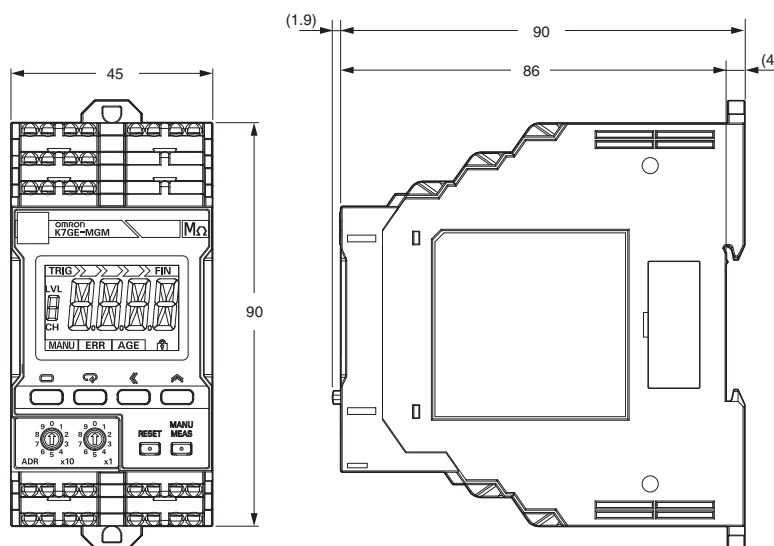

Probe Unit  
K7GE-MG1

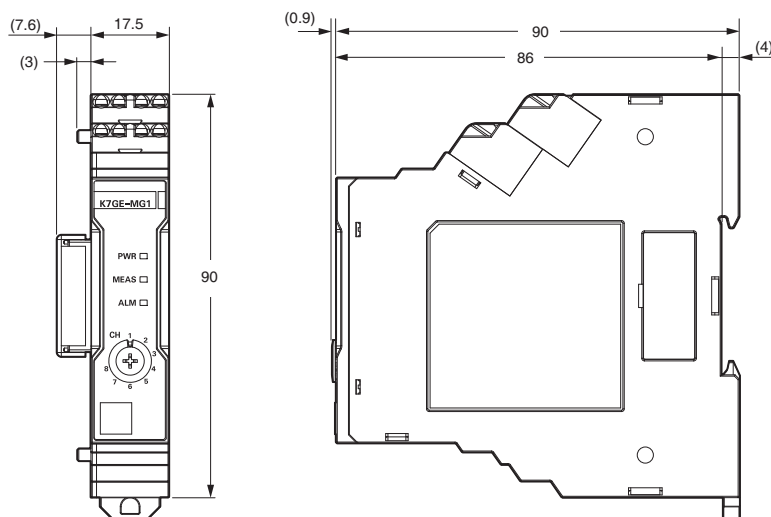

Optional Products for DIN Track Mounting

DIN Tracks  
PFP-100N  
PFP-50N

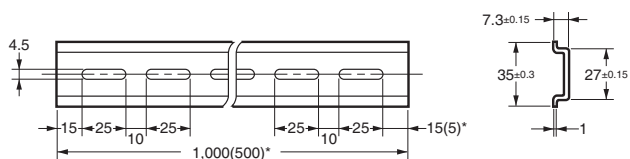
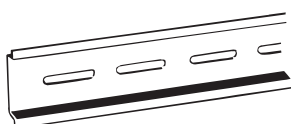

\* Dimensions in parentheses are for the PFP-50N.

End Plate  
PFP-M

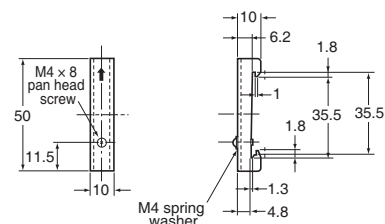

Setting Parameter Flow

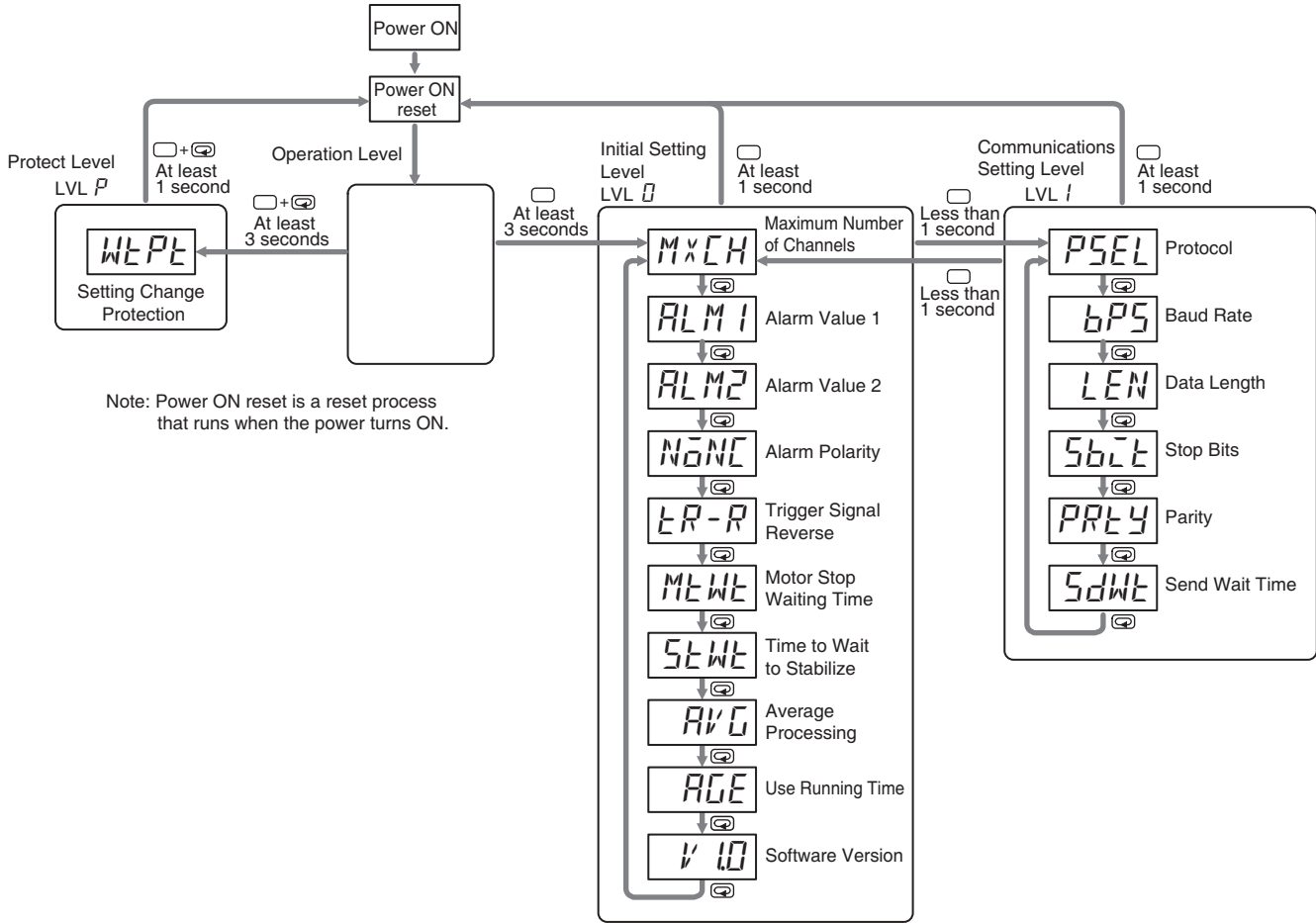

Level	Parameter name	Characters	Setting range	Description
Protect	Setting Change Protection	WLPt	OFF/ON	Use key operations to change the setting value, <b>Enabled</b> /Disabled
Initial Setting	Maximum Number of Channels	MxCH	<u>1</u> to 8	Total number of channels, default value: <u>1</u>
	Alarm Value 1	ALM1	0.0 to 99.9 MΩ	Alarm threshold value (warning), default value: <b>20.0</b>
	Alarm Value 2	ALM2	0.0 to 99.9 MΩ	Alarm threshold value (critical), default value: <b>1.0</b>
	Alarm Polarity	NONC	n-o/n-c	Alarm output polarity, Normally open/ <b>Normally close</b>
	Trigger Signal Reverse	LR-R	OFF/ON	<b>Start measurement when trigger contact input is OFF</b> / Start measurement when trigger contact input is ON
	Motor Stop Waiting Time	MtWt	0 to 299 s	Time from trigger input to load stopping, default value: <b>10</b>
	Time to Wait to Stabilize	StWt	0 to 99 s	Time for the measurement value to stabilize after the Megger voltage is applied, default value: <b>60</b>
	Average Processing	AVG	OFF/ON	Average processing of measurement values, <b>None</b> /Yes
	Use Running Time	RGE	OFF/ON	Running time estimation function, <b>Not used</b> /Used
	Software Version	V ID	-	Displays the software version of the K7GE-MG. * The version number depends on the current software version.
Communications Setting	Protocol	PSEL	CWF/MOD	Protocol selection, <b>CompoWay/F</b> / Modbus RTU
	Baud Rate	bPS	<b>9.6</b> /19.2/38.4/57.6 kbps	Baud rate, default value: <b>9.6</b>
	Data Length	LEN	<b>7</b> /8 bits	Data length, default value: <b>7</b>
	Stop Bits	StBt	<b>1</b> / <b>2</b> bits	Stop bits, default value: <b>2</b>
	Parity	PRtY	NONE/ <b>EVEN</b> /ODD	Parity, default value: <b>EVEN</b>
Send Wait Time	SdWt	0 to 99 ms	Response wait time from the host, default value: <b>20</b>	

Note: **Bold text values** indicate default settings.

## K7GE-MG Logging Tool

The K7GE-MG Logging Tool (this tool) makes it easy to perform remote monitoring.

Measurement time	CH1			CH2			CH3			CH4			CH5			CH6		
	Mean	ALM1	ALM2	Mean	ALM1	ALM2	Mean	ALM1	ALM2	Mean	ALM1	ALM2	Mean	ALM1	ALM2	Mean	ALM1	ALM2
2020/12/1 18:00	99.9	0	0	21.0	0	0	99.9	0	0	99.9	0	0	99.9	0	0	99.9	0	0
2020/12/2 18:00	99.9	0	0	21.1	0	0	99.9	0	0	99.9	0	0	99.9	0	0	99.9	0	0
2020/12/3 18:00	99.9	0	0	20.7	0	0	99.9	0	0	99.9	0	0	99.9	0	0	99.9	0	0
2020/12/4 18:00	99.9	0	0	20.2	0	0	99.9	0	0	99.9	0	0	99.9	0	0	99.9	0	0
2020/12/7 18:00	99.9	0	0	18.5	1	0	99.9	0	0	99.9	0	0	99.9	0	0	99.9	0	0
2020/12/8 18:00	99.9	0	0	18.3	1	0	99.9	0	0	99.9	0	0	99.9	0	0	99.9	0	0
2020/12/9 18:00	99.9	0	0	18.2	1	0	99.9	0	0	99.9	0	0	99.9	0	0	99.9	0	0
2020/12/10 18:00	99.9	0	0	18.0	1	0	99.9	0	0	99.9	0	0	99.9	0	0	99.9	0	0

The main specifications of the tool are as follows:

- Data for up to five sets of the monitoring device can be logged.
- A maximum of eight Probe Units can be included in one set.
- The measurement values and alarm status data for each set can be logged.  
Up to 1,000 values of data can be logged.
- The setting parameters can be read and written.

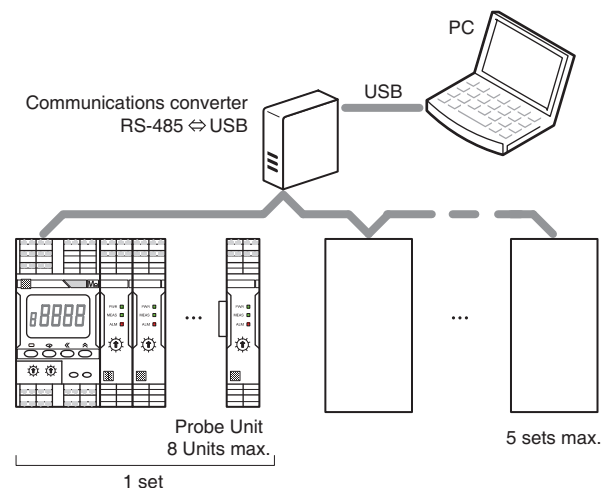

The system requirements are as follows.

<b>Supported OS</b>	Windows 10 64-bit edition, English or Japanese
<b>PC specifications</b>	1 GHz or faster CPU, 1 GB or more of RAM, and 16 GB or more of reserved disk area
<b>Excel</b>	Excel 2019 32-bit or 64-bit edition, English or Japanese * For Excel 2013/2016 32-bit edition, OMRON performed a connection test only on the Japanese version in combination with the Japanese version of Windows 10.
<b>RS485-USB communications converter</b>	Use a commercially available product. * OMRON performed an evaluation test on the SI-35USB-2 manufactured by LINE EYE. (The driver version is V2.12.18.)

Refer to Help in this tool for details on using this tool.

You can download the latest version of this tool from the following OMRON website.

[https://www.ia.omron.com/k7ge\\_tool](https://www.ia.omron.com/k7ge_tool)

In the interest of product improvement, the K7GE-MG Logging Tool specifications are subject to change without notice.

# K7GE-MG

## Conformance to Safety Standards

- For wiring from the Probe Unit to the load, use a Class CC, Class J, or Class T fuse with a rated current of 7 A or less.
- The protection provided by the device may be impaired if the device is used in a manner that is not specified by the manufacturer.
- To use the Product, install it as an embedded device within a control panel.
- The table below shows the nominal voltage and measurement circuit connections available for each measurement category in the Main Power Supply System Configurations. Do not use the device under conditions that exceed this category and conditions.

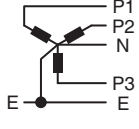
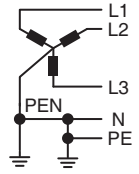
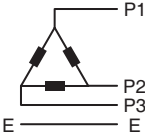
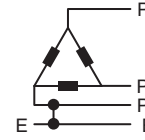
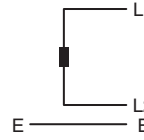
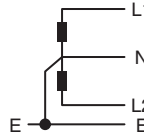
Main Power Supply System Configurations					
	3-phase, 4-wire type (neutral point grounding) TT  TN-C-S 	3-phase, 3-wire type (no grounding) 	3-phase, 3-wire type (single-phase grounding) 	Single-phase, 2-wire type AC or DC 	Single-phase (split phase), 2-wire type AC or DC 
<b>CAT III</b>	Phase voltage/line voltage 277 V/480 V	Line voltage 300 V	Line voltage 300 V	Line voltage 240 V	Phase voltage/ line voltage 240 V/480 V
<b>CAT II</b>	347 V/600 V in addition to the above	480 V in addition to the above	480 V in addition to the above	480 V in addition to the above	Same as above
<b>Connection to measurement circuit</b>	<b>TT:</b> Connect E in the diagram above to the No. 7 terminal (PE) of the K7GE-MGM. Connect P1 and P2 to the No. 1 and No. 3 terminals of the K7GE-MG1.	Connect E in the diagram above to the No. 7 terminal (PE) of the K7GE-MGM. Connect P1 and P2 to the No. 1 and No. 3 terminals of the K7GE-MG1.	Connect E in the diagram above to the No. 7 terminal (PE) of the K7GE-MGM. Connect L1 and L2 to the No. 1 and No. 3 terminals of the K7GE-MG1.		
	<b>TN-C-S:</b> Connect PE in the diagram above to the No. 7 terminal (PE) of the K7GE-MGM. Connect L1 and L2 to the No. 1 and No. 3 terminals of the K7GE-MG1.				

### Measurement Category

The measurement category classifies the places and equipment entry wire which you can connect to the measurement terminals, as prescribed in EN/IEC 61010-2-030.

Each category is as follows.

- CAT I:** Equipment to connect to circuits where measures are taken to limit transient overvoltages to low levels
- CAT II:** Energy-consuming equipment with an energy supply from fixed wiring equipment (such as a power outlet)
- CAT III:** Equipment in fixed wiring equipment that particularly demands equipment reliability and effectiveness
- CAT IV:** Equipment to use at the electrical service entry

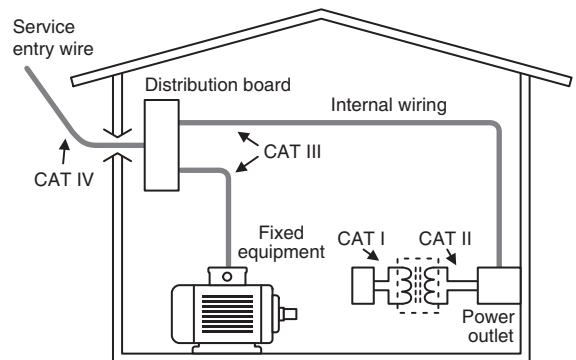

Microsoft, Windows is either registered trademarks or trademarks of Microsoft Corporation in the United States and other countries.

Megger is a registered trademark or trademark of Megger Group Limited.

Modbus is a registered trademark or trademark of Schneider Electric USA, Inc. in Japan, the United States or other countries.

Other company names and product names in this document are the trademarks or registered trademarks of their respective companies.

# Terms and Conditions Agreement

## **Read and understand this catalog.**

Please read and understand this catalog before purchasing the products. Please consult your OMRON representative if you have any questions or comments.

## **Warranties.**

(a) Exclusive Warranty. Omron's exclusive warranty is that the Products will be free from defects in materials and workmanship for a period of twelve months from the date of sale by Omron (or such other period expressed in writing by Omron). Omron disclaims all other warranties, express or implied.

(b) Limitations. OMRON MAKES NO WARRANTY OR REPRESENTATION, EXPRESS OR IMPLIED, ABOUT NON-INFRINGEMENT, MERCHANTABILITY OR FITNESS FOR A PARTICULAR PURPOSE OF THE PRODUCTS. BUYER ACKNOWLEDGES THAT IT ALONE HAS DETERMINED THAT THE PRODUCTS WILL SUITABLY MEET THE REQUIREMENTS OF THEIR INTENDED USE.

Omron further disclaims all warranties and responsibility of any type for claims or expenses based on infringement by the Products or otherwise of any intellectual property right. (c) Buyer Remedy. Omron's sole obligation hereunder shall be, at Omron's election, to (i) replace (in the form originally shipped with Buyer responsible for labor charges for removal or replacement thereof) the non-complying Product, (ii) repair the non-complying Product, or (iii) repay or credit Buyer an amount equal to the purchase price of the non-complying Product; provided that in no event shall Omron be responsible for warranty, repair, indemnity or any other claims or expenses regarding the Products unless Omron's analysis confirms that the Products were properly handled, stored, installed and maintained and not subject to contamination, abuse, misuse or inappropriate modification. Return of any Products by Buyer must be approved in writing by Omron before shipment. Omron Companies shall not be liable for the suitability or unsuitability or the results from the use of Products in combination with any electrical or electronic components, circuits, system assemblies or any other materials or substances or environments. Any advice, recommendations or information given orally or in writing, are not to be construed as an amendment or addition to the above warranty.

See <http://www.omron.com/global/> or contact your Omron representative for published information.

## **Limitation on Liability; Etc.**

OMRON COMPANIES SHALL NOT BE LIABLE FOR SPECIAL, INDIRECT, INCIDENTAL, OR CONSEQUENTIAL DAMAGES, LOSS OF PROFITS OR PRODUCTION OR COMMERCIAL LOSS IN ANY WAY CONNECTED WITH THE PRODUCTS, WHETHER SUCH CLAIM IS BASED IN CONTRACT, WARRANTY, NEGLIGENCE OR STRICT LIABILITY.

Further, in no event shall liability of Omron Companies exceed the individual price of the Product on which liability is asserted.

## **Suitability of Use.**

Omron Companies shall not be responsible for conformity with any standards, codes or regulations which apply to the combination of the Product in the Buyer's application or use of the Product. At Buyer's request, Omron will provide applicable third party certification documents identifying ratings and limitations of use which apply to the Product. This information by itself is not sufficient for a complete determination of the suitability of the Product in combination with the end product, machine, system, or other application or use. Buyer shall be solely responsible for determining appropriateness of the particular Product with respect to Buyer's application, product or system. Buyer shall take application responsibility in all cases.

NEVER USE THE PRODUCT FOR AN APPLICATION INVOLVING SERIOUS RISK TO LIFE OR PROPERTY OR IN LARGE QUANTITIES WITHOUT ENSURING THAT THE SYSTEM AS A WHOLE HAS BEEN DESIGNED TO ADDRESS THE RISKS, AND THAT THE OMRON PRODUCT(S) IS PROPERLY RATED AND INSTALLED FOR THE INTENDED USE WITHIN THE OVERALL EQUIPMENT OR SYSTEM.

## **Programmable Products.**

Omron Companies shall not be responsible for the user's programming of a programmable Product, or any consequence thereof.

## **Performance Data.**

Data presented in Omron Company websites, catalogs and other materials is provided as a guide for the user in determining suitability and does not constitute a warranty. It may represent the result of Omron's test conditions, and the user must correlate it to actual application requirements. Actual performance is subject to the Omron's Warranty and Limitations of Liability.

## **Change in Specifications.**

Product specifications and accessories may be changed at any time based on improvements and other reasons. It is our practice to change part numbers when published ratings or features are changed, or when significant construction changes are made. However, some specifications of the Product may be changed without any notice. When in doubt, special part numbers may be assigned to fix or establish key specifications for your application. Please consult with your Omron's representative at any time to confirm actual specifications of purchased Product.

## **Errors and Omissions.**

Information presented by Omron Companies has been checked and is believed to be accurate; however, no responsibility is assumed for clerical, typographical or proofreading errors or omissions.

## KC Mark 표준 준수

### 사 용 자 안 내 문

이 기기는 업무용 환경에서  
사용할 목적으로 적합성평가를 받은  
기기로서 가정용 환경에서 사용하는  
경우 전파간섭의 우려가 있습니다.

**OMRON Corporation Industrial Automation Company**  
Kyoto, JAPAN

Contact: [www.ia.omron.com](http://www.ia.omron.com)

**Regional Headquarters**

**OMRON EUROPE B.V.**

Wegalaan 67-69, 2132 JD Hoofddorp  
The Netherlands  
Tel: (31)2356-81-300/Fax: (31)2356-81-388

**OMRON ELECTRONICS LLC**

2895 Greenspoint Parkway, Suite 200  
Hoffman Estates, IL 60169 U.S.A.  
Tel: (1) 847-843-7900/Fax: (1) 847-843-7787

**OMRON ASIA PACIFIC PTE. LTD.**

No. 438A Alexandra Road # 05-05/08 (Lobby 2),  
Alexandra Technopark,  
Singapore 119967  
Tel: (65) 6835-3011/Fax: (65) 6835-2711

**OMRON (CHINA) CO., LTD.**

Room 2211, Bank of China Tower,  
200 Yin Cheng Zhong Road,  
PuDong New Area, Shanghai, 200120, China  
Tel: (86) 21-5037-2222/Fax: (86) 21-5037-2200

Authorized Distributor:

© OMRON Corporation 2020 All Rights Reserved.  
In the interest of product improvement,  
specifications are subject to change without notice.

Cat. No. N225-E1-01

1220 (1220)