

BGX220P Wireless Gecko Bluetooth Xpress Module Data Sheet



The BGX220P is a wireless cable replacement module that eliminates Bluetooth firmware development complexity with a serial interface that can operate as a raw data stream or control the device through a abstracted command API. The BGX220P can facilitate a device-to-device cable replacement link or communicate with mobile devices through the Xpress Bluetooth mobile library. The device integrates a Bluetooth 5.2 compliant stack to future-proof applications as Bluetooth 5.2 adoption increases.

BGX220P modules are a full solution that comes with fully-upgradeable, robust software stacks, world-wide regulatory certifications, and support that will minimize and simplify the engineering and development of your end-products helping to accelerate their time-to-market.

The BGX220P is intended for a broad range of applications, including:

- Health, sports, and wellness devices
- Industrial, home, and building automation
- Smart phone, tablet, and PC accessories

KEY FEATURES

- Bluetooth 5.2 Technologies
- Bluetooth Low Energy
- Built-in antenna
- Up to 8 dBm TX power
- -98.9 dBm BLE RX sensitivity at 1 Mbps
- 8 GPIO pins
- I2C master interface
- Input pin event monitoring and response
- 12.9 mm x 15.0 mm

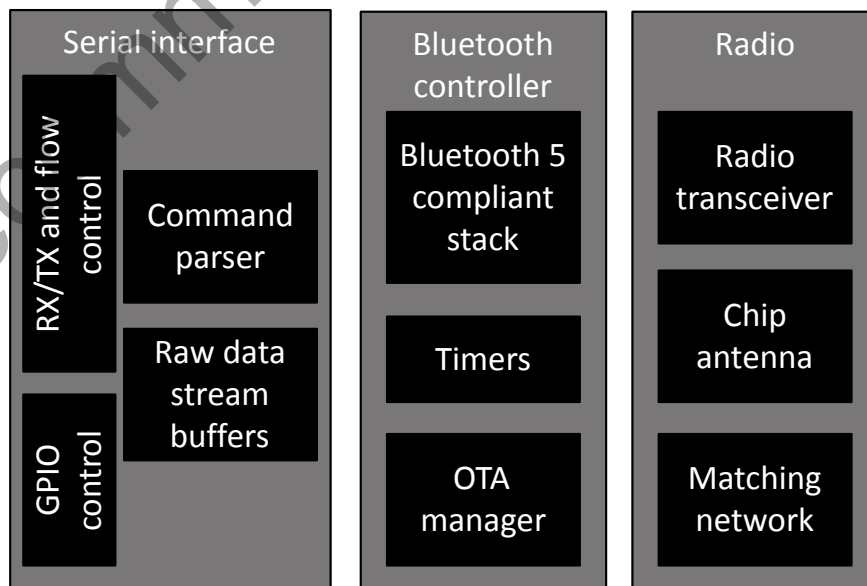

1. Ordering Information

Table 1.1. Ordering Information

Ordering Code	Protocol Stack	TX Power Rating	Antenna	RF Shield	Flash (kB)	RAM (kB)	LF Clock	GPIO	Temp Range
BGX220P22HNA21	• Bluetooth 5.2	8 dBm	Built-in	Yes	512	32	Crystal	8	-40 to 105 °C

Note:

1. End-product manufacturers must verify that the module is configured to meet regulatory limits for each region in accordance with the formal certification test reports.
2. Throughout this document, the device in the table above may be referred to by their product family name (e.g. BGX220P), by model name (BGX220P22A), or by full ordering code.

Not Recommended for New Designs

Table of Contents

1. Ordering Information	2
2. System Overview	5
2.1 Block Diagram	5
2.2 EFR32BG22 SoC	6
2.3 Antenna	6
2.4 Power Supply	6
3. Electrical Characteristics	7
3.1 Absolute Maximum Ratings	7
3.2 General Operating Conditions	7
3.2.1 DC-DC Operating Limits	8
3.3 Power Consumption	9
3.4 RF Transmitter General Characteristics for the 2.4 GHz Band	10
3.5 RF Receiver General Characteristics for the 2.4 GHz Band	10
3.6 RF Receiver Characteristics for Bluetooth Low Energy in the 2.4 GHz Band 1 Mbps Data Rate	11
3.7 RF Receiver Characteristics for Bluetooth Low Energy in the 2.4 GHz Band 2 Mbps Data Rate	12
3.8 RF Receiver Characteristics for Bluetooth Low Energy in the 2.4 GHz Band 500 kbps Data Rate	13
3.9 RF Receiver Characteristics for Bluetooth Low Energy in the 2.4 GHz Band 125 kbps Data Rate	14
3.10 Non-Volatile Configuration Storage	15
3.11 High-Frequency Crystal	15
3.12 GPIO Pins	16
3.13 Typical Performance Curves	16
3.13.1 Antenna Radiation and Efficiency	17
4. Reference Diagrams	18
4.1 Typical Connections	18
5. Pin Definitions	19
5.1 BGX220P Device Pinout	19
6. Functional overview	21
6.1 Introduction	21
6.2 Communication Use Cases	21
6.3 Embedded Interface	21
6.4 Command Mode and Streaming Mode	21
6.5 Command API	22
6.6 GPIO Control	22
6.7 Device Configuration	22
6.8 Security Features	22

6.9	OTA	.22
6.10	Direct Test Mode Support	.22
7.	Design Guidelines	.23
7.1	Layout and Placement	.23
7.2	Proximity to Other Materials	.24
7.3	Proximity to Human Body	.24
8.	Package Specifications	.25
8.1	Dimensions	.25
8.2	PCB Land Pattern	.26
8.3	Package Marking	.27
9.	Soldering Recommendations	.28
10.	Tape and Reel	.29
11.	Certifications	.30
11.1	Qualified Antennas	.30
11.2	EU - CE	.30
11.3	USA - FCC	.30
11.4	ISED Canada	.33
11.5	Proximity to Human Body	.35
11.6	Japan - MIC	.36
11.7	South Korea - KC	.37
11.8	Bluetooth Qualification	.37
12.	Revision History	.38

2. System Overview

2.1 Block Diagram

The BGX220P module combines an energy-friendly MCU with a highly integrated radio transceiver in a PCB module with a robust, integrated antenna. This section gives a short introduction to the features of the module. Note that features in the module are not directly configurable in this pre-programmed product, and are instead controlled through the abstracted command and variable set.

The block diagram for the BGX220P module is shown in [Figure 2.1 BGX220P Block Diagram on page 5](#). The wireless module includes the EFR32BG22 wireless System on a Chip (SoC), required decoupling capacitors and inductors, 38.4 MHz and 32.768 kHz crystals, RF matching circuit, and integrated chip antenna.

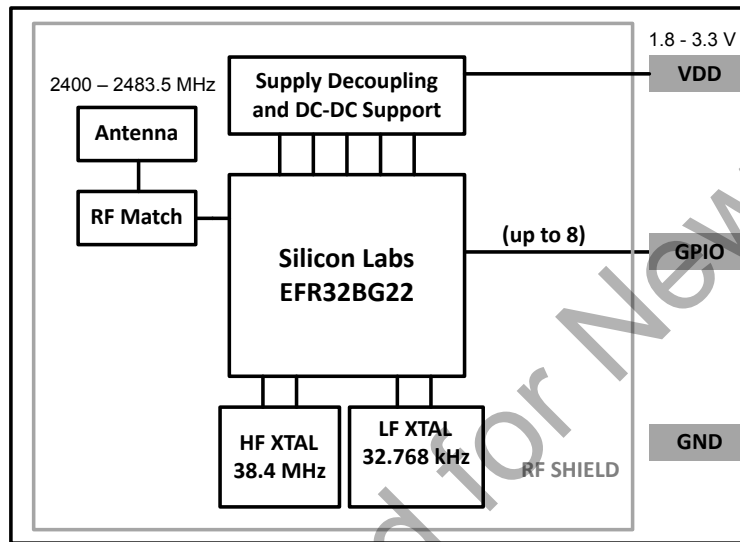

Figure 2.1. BGX220P Block Diagram

A simplified internal schematic for the BGX220P module is shown in [Figure 2.2 BGX220P Module Schematic on page 5](#).

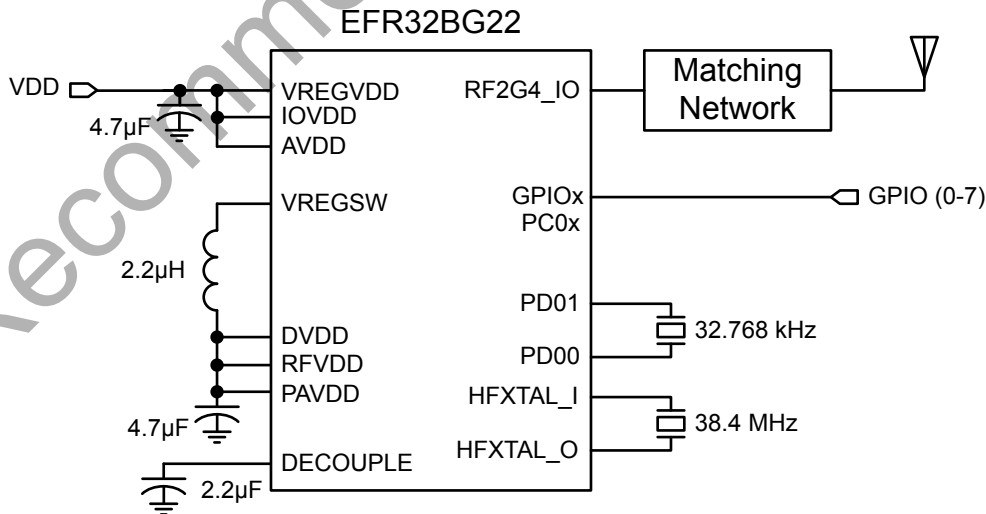

Figure 2.2. BGX220P Module Schematic

2.2 EFR32BG22 SoC

The EFR32BG22 SoC features a 32-bit ARM Cortex M33 core, a 2.4 GHz high-performance radio, 512 kB of flash memory, a rich set of MCU peripherals, and various clock management and serial interfacing options. Consult the [EFR32xG22 Wireless Gecko Reference Manual](#) and the [EFR32BG22 Data Sheet](#) for details.

Note that the Flash and other features in this product are not directly accessible, and are instead accessed through the product's abstracted command and variable set.

2.3 Antenna

BGX220P modules include a ceramic chip antenna on board with the characteristics detailed in the table below.

Table 2.1. Antenna Efficiency and Peak Gain

Parameter	With optimal layout	Note
Efficiency	-1 dB	Antenna efficiency, gain and radiation pattern are highly dependent on the application PCB layout and mechanical design. Refer to Design Guidelines for recommendations to achieve optimal antenna performance.
Peak gain	1.86 dBi	

2.4 Power Supply

The BGX220P requires a single nominal supply level of 3.0 V to operate. All necessary decoupling and filtering components are included in the module.

3. Electrical Characteristics

All electrical parameters in all tables are specified under the following conditions, unless stated otherwise:

- Typical values are based on $T_A=25\text{ }^\circ\text{C}$ and VDD supply at 3.0 V, by production test and/or technology characterization.
- Radio performance numbers are measured in conducted mode, based on Silicon Laboratories reference designs using output power-specific external RF impedance-matching networks for interfacing to a 50 Ω antenna.
- Minimum and maximum values represent the worst conditions across supply voltage, process variation, and operating temperature, unless stated otherwise.

3.1 Absolute Maximum Ratings

Stresses beyond those listed below may cause permanent damage to the device. This is a stress rating only and functional operation of the devices at those or any other conditions beyond those indicated in the operation listings of this specification is not implied. Exposure to maximum rating conditions for extended periods may affect device reliability. For more information on the available quality and reliability data, see the Quality and Reliability Monitor Report at <http://www.silabs.com/support/quality/pages/default.aspx>.

Table 3.1. Absolute Maximum Ratings

Parameter	Symbol	Test Condition	Min	Typ	Max	Unit
Storage temperature range	T_{STG}		-40	—	+105	$^\circ\text{C}$
Voltage on VDD supply pin	V_{DDMAX}		-0.3	—	3.8	V
Voltage ramp rate on VDD supply pin	$V_{DDRAMPMAX}$		—	—	1.0	V / μs
DC voltage on any GPIO pin	V_{DIGPIN}		-0.3	—	$V_{VDD} + 0.3$	V
Total current into VDD pin	I_{VDDMAX}	Source	—	—	200	mA
Total current into GND pin	$I_{GNDDMAX}$	Sink	—	—	200	mA
Current per I/O pin	I_{IOMAX}	Sink	—	—	50	mA
		Source	—	—	50	mA
Current for all I/O pins	$I_{IOALLMAX}$	Sink	—	—	200	mA
		Source	—	—	200	mA

3.2 General Operating Conditions

This table specifies the general operating temperature range and supply voltage range for all supplies. The minimum and maximum values of all other tables are specified over this operating range, unless otherwise noted.

Table 3.2. General Operating Conditions

Parameter	Symbol	Test Condition	Min	Typ	Max	Unit
Operating ambient temperature range	T_A	-N temperature grade	-40	—	+105	$^\circ\text{C}$
VDD operating supply voltage	V_{VDD}	DCDC in regulation ¹	2.2	3.0	3.8	V
		DCDC in bypass	1.8	3.0	3.8	V

Note:

1. The supported maximum V_{VDD} in regulation mode is a function of temperature and 10-year lifetime average load current.

3.2.1 DC-DC Operating Limits

The maximum supported voltage on the VDD supply pin is limited under certain conditions. Maximum input voltage is a function of temperature and the average load current over a 10-year lifetime. [Figure 3.1 Lifetime average load current limit vs. Maximum input voltage on page 8](#) shows the safe operating region under specific conditions. Exceeding this safe operating range may impact the reliability and performance of the DC-DC converter.

The average load current for an application can typically be determined by examining the current profile during the time the device is powered. For example, an application that is continuously powered which spends 99% of the time asleep consuming 2 μA and 1% of the time active and consuming 10 mA has an average lifetime load current of about 102 μA .

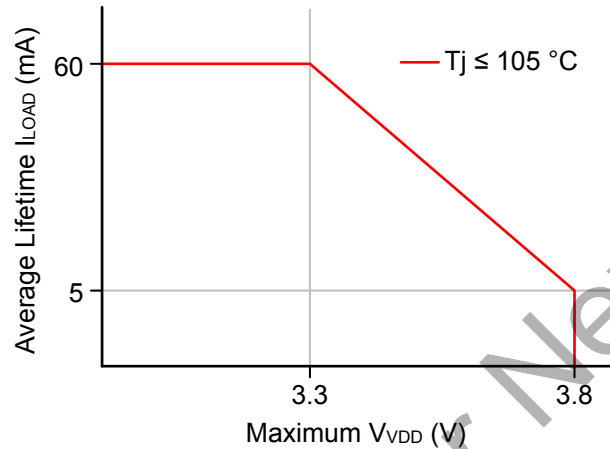

Figure 3.1. Lifetime average load current limit vs. Maximum input voltage

The minimum input voltage for the DC-DC in EM0/EM1 mode is a function of the maximum load current, and the peak current setting. [Figure 3.2 Transient maximum load current vs. Minimum input voltage on page 8](#) shows the max load current vs. input voltage for different DC-DC peak inductor current settings.

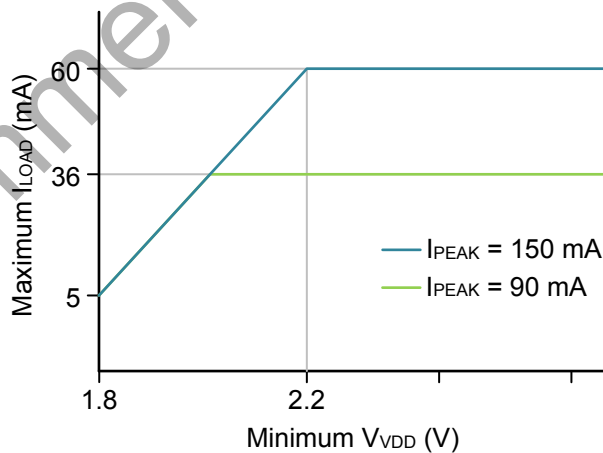

Figure 3.2. Transient maximum load current vs. Minimum input voltage

3.3 Power Consumption

Table 3.3. Power Consumption

Parameter	Symbol	Test Condition	Min	Typ	Max	Unit
Active supply current, Unconnected, Idle	I _{ACTIVE_IDLE}	Baud rate ≤ 9600 bps	—	1.4	—	μA
		Baud rate > 9600 bps	—	1.1	—	mA
Active supply current, Advertising	I _{ACTIVE_ADV}	Interval = 546.25 ms, Baud rate ≤ 9600 bps	—	37	—	μA
		Interval = 20 ms, Baud rate ≤ 9600 bps	—	0.69	—	mA
		Interval = 546.25 ms, Baud rate > 9600 bps	—	1.1	—	mA
		Interval = 20 ms, Baud rate > 9600 bps	—	1.7	—	mA
Active supply current, Connected, 15 ms Interval	I _{ACTIVE_CONN}	Idle, Baud Rate ≤ 9600 bps	—	350	—	μA
		TX/RX (acknowledged) at highest throughput, Baud Rate ≤ 9600 bps	—	TX: 4.6 RX: 4.0	—	mA
		TX/RX (unacknowledged) at highest throughput, Baud Rate ≤ 9600 bps	—	TX: 4.3 RX: 3.1	—	mA
		Idle, Baud Rate > 9600 bps	—	3.6	—	mA
		TX/RX (acknowledged) at highest throughput, Baud Rate > 9600 bps	—	TX: 4.4 RX: 3.9	—	mA
		TX/RX (unacknowledged) at highest throughput, Baud Rate > 9600 bps	—	TX: 4.4 RX: 3.8	—	mA
Supply current in low power mode	I _{LPM}	Radio disabled	—	2	—	μA
		Radio enabled, Advertising, Interval = 546.25 ms	—	33	—	μA
		Radio enabled, Advertising, Interval = 20 ms	—	0.68	—	mA

3.4 RF Transmitter General Characteristics for the 2.4 GHz Band

Unless otherwise indicated, typical conditions are: $T_A = 25\text{ }^\circ\text{C}$, $V_{DD} = 3.0\text{V}$. RF center frequency 2.45 GHz.

Table 3.4. RF Transmitter General Characteristics for the 2.4 GHz Band

Parameter	Symbol	Test Condition	Min	Typ	Max	Unit
RF tuning frequency range	F_{RANGE}		2400	—	2483.5	MHz
Maximum TX power ¹	$POUT_{\text{MAX}}$	8 dBm output power	—	8.2	—	dBm
		6 dBm output power	—	6.4	—	dBm
Minimum active TX Power	$POUT_{\text{MIN}}$	8 dBm output power	—	-27	—	dBm
		6 dBm output power	—	-27	—	dBm
Output power variation vs VDD supply voltage variation, frequency = 2450 MHz	$POUT_{\text{VAR}_V}$	8 dBm output power with VDD voltage swept from 1.8 V to 3.0 V	—	0.04	—	dB
		6 dBm output power with VDD voltage swept from 1.8 V to 3.0 V	—	0.04	—	dB
Output power variation vs temperature, Frequency = 2450 MHz	$POUT_{\text{VAR}_T}$	8 dBm output power, (-40 to +105 °C)	—	0.9	—	dB
		6 dBm output power, (-40 to +105 °C)	—	0.3	—	dB
Output power variation vs RF frequency	$POUT_{\text{VAR}_F}$	8 dBm output power	—	0.2	—	dB
		6 dBm output power	—	0.2	—	dB

Note:

- Supported transmit power levels are determined by the ordering part number (OPN). Transmit power ratings for all devices covered in this data sheet can be found in the Max TX Power column of the Ordering Information Table.

3.5 RF Receiver General Characteristics for the 2.4 GHz Band

Unless otherwise indicated, typical conditions are: $T_A = 25\text{ }^\circ\text{C}$, $V_{DD} = 3.0\text{V}$. RF center frequency 2.45 GHz.

Table 3.5. RF Receiver General Characteristics for the 2.4 GHz Band

Parameter	Symbol	Test Condition	Min	Typ	Max	Unit
RF tuning frequency range	F_{RANGE}		2400	—	2483.5	MHz

3.6 RF Receiver Characteristics for Bluetooth Low Energy in the 2.4 GHz Band 1 Mbps Data Rate

 Unless otherwise indicated, typical conditions are: $T_A = 25\text{ }^\circ\text{C}$, $V_{DD} = 3.0\text{V}$. RF center frequency 2.45 GHz.

Table 3.6. RF Receiver Characteristics for Bluetooth Low Energy in the 2.4 GHz Band 1 Mbps Data Rate

Parameter	Symbol	Test Condition	Min	Typ	Max	Unit
Max usable receiver input level	SAT	Signal is reference signal ¹	—	10	—	dBm
Sensitivity	SENS	Signal is reference signal, 37 byte payload ²	—	-98.9	—	dBm
		Signal is reference signal, 255 byte payload ¹	—	-97.4	—	dBm
		With non-ideal signals ^{3 1}	—	-96.9	—	dBm
Signal to co-channel interferer	C/I_{CC}	(see notes) ^{1 4}	—	8.7	—	dB
$N \pm 1$ Adjacent channel selectivity	C/I_1	Interferer is reference signal at +1 MHz offset ^{1 5 4 6}	—	-6.6	—	dB
		Interferer is reference signal at -1 MHz offset ^{1 5 4 6}	—	-6.5	—	dB
$N \pm 2$ Alternate channel selectivity	C/I_2	Interferer is reference signal at +2 MHz offset ^{1 5 4 6}	—	-40.9	—	dB
		Interferer is reference signal at -2 MHz offset ^{1 5 4 6}	—	-39.9	—	dB
$N \pm 3$ Alternate channel selectivity	C/I_3	Interferer is reference signal at +3 MHz offset ^{1 5 4 6}	—	-45.9	—	dB
		Interferer is reference signal at -3 MHz offset ^{1 5 4 6}	—	-46.2	—	dB
Selectivity to image frequency	C/I_{IM}	Interferer is reference signal at image frequency with 1 MHz precision ^{1 6}	—	-23.5	—	dB
Selectivity to image frequency ± 1 MHz	$C/I_{IM,1}$	Interferer is reference signal at image frequency +1 MHz with 1 MHz precision ^{1 6}	—	-40.9	—	dB
		Interferer is reference signal at image frequency -1 MHz with 1 MHz precision ^{1 6}	—	-6.6	—	dB
Intermodulation performance	IM	$n = 3$ (see note ⁷)	—	-17.1	—	dBm

Note:

1. 0.017% Bit Error Rate.
2. 0.1% Bit Error Rate.
3. With non-ideal signals as specified in Bluetooth Test Specification RF-PHY.TS.5.0.1 section 4.7.1
4. Desired signal -67 dBm.
5. Desired frequency $2402\text{ MHz} \leq F_c \leq 2480\text{ MHz}$.
6. With allowed exceptions.
7. As specified in Bluetooth Core specification version 5.1, Vol 6, Part A, Section 4.4

3.7 RF Receiver Characteristics for Bluetooth Low Energy in the 2.4 GHz Band 2 Mbps Data Rate

 Unless otherwise indicated, typical conditions are: $T_A = 25\text{ }^\circ\text{C}$, $V_{DD} = 3.0\text{V}$. RF center frequency 2.45 GHz.

Table 3.7. RF Receiver Characteristics for Bluetooth Low Energy in the 2.4 GHz Band 2 Mbps Data Rate

Parameter	Symbol	Test Condition	Min	Typ	Max	Unit
Max usable receiver input level	SAT	Signal is reference signal ¹	—	10	—	dBm
Sensitivity	SENS	Signal is reference signal, 37 byte payload ²	—	-96.2	—	dBm
		Signal is reference signal, 255 byte payload ¹	—	-94.6	—	dBm
		With non-ideal signals ^{3 1}	—	-94.4	—	dBm
Signal to co-channel interferer	C/I_{CC}	(see notes) ^{1 4}	—	8.8	—	dB
$N \pm 1$ Adjacent channel selectivity	C/I_1	Interferer is reference signal at +2 MHz offset ^{1 5 4 6}	—	-9.2	—	dB
		Interferer is reference signal at -2 MHz offset ^{1 5 4 6}	—	-6.6	—	dB
$N \pm 2$ Alternate channel selectivity	C/I_2	Interferer is reference signal at +4 MHz offset ^{1 5 4 6}	—	-43.3	—	dB
		Interferer is reference signal at -4 MHz offset ^{1 5 4 6}	—	-44.0	—	dB
$N \pm 3$ Alternate channel selectivity	C/I_3	Interferer is reference signal at +6 MHz offset ^{1 5 4 6}	—	-48.6	—	dB
		Interferer is reference signal at -6 MHz offset ^{1 5 4 6}	—	-50.7	—	dB
Selectivity to image frequency	C/I_{IM}	Interferer is reference signal at image frequency with 1 MHz precision ^{1 6}	—	-23.8	—	dB
Selectivity to image frequency ± 2 MHz	$C/I_{IM,1}$	Interferer is reference signal at image frequency +2 MHz with 1 MHz precision ^{1 6}	—	-43.3	—	dB
		Interferer is reference signal at image frequency -2 MHz with 1 MHz precision ^{1 6}	—	-9.2	—	dB
Intermodulation performance	IM	$n = 3$ (see note ⁷)	—	-18.8	—	dBm

Note:

1. 0.017% Bit Error Rate.
2. 0.1% Bit Error Rate.
3. With non-ideal signals as specified in Bluetooth Test Specification RF-PHY.TS.5.0.1 section 4.7.1
4. Desired signal -64 dBm.
5. Desired frequency $2402\text{ MHz} \leq F_c \leq 2480\text{ MHz}$.
6. With allowed exceptions.
7. As specified in Bluetooth Core specification version 5.1, Vol 6, Part A, Section 4.4

3.8 RF Receiver Characteristics for Bluetooth Low Energy in the 2.4 GHz Band 500 kbps Data Rate

Unless otherwise indicated, typical conditions are: $T_A = 25\text{ }^\circ\text{C}$, $V_{DD} = 3.0\text{V}$. RF center frequency 2.45 GHz.

Table 3.8. RF Receiver Characteristics for Bluetooth Low Energy in the 2.4 GHz Band 500 kbps Data Rate

Parameter	Symbol	Test Condition	Min	Typ	Max	Unit
Max usable receiver input level	SAT	Signal is reference signal ¹	—	10	—	dBm
Sensitivity	SENS	Signal is reference signal, 37 byte payload ²	—	-102.5	—	dBm
		Signal is reference signal, 255 byte payload ¹	—	-101.2	—	dBm
		With non-ideal signals ^{3 1}	—	-100.2	—	dBm
Signal to co-channel interferer	C/I_{CC}	(see notes) ^{1 4}	—	2.7	—	dB
$N \pm 1$ Adjacent channel selectivity	C/I_1	Interferer is reference signal at +1 MHz offset ^{1 5 4 6}	—	-8.0	—	dB
		Interferer is reference signal at -1 MHz offset ^{1 5 4 6}	—	-7.9	—	dB
$N \pm 2$ Alternate channel selectivity	C/I_2	Interferer is reference signal at +2 MHz offset ^{1 5 4 6}	—	-46.5	—	dB
		Interferer is reference signal at -2 MHz offset ^{1 5 4 6}	—	-49.9	—	dB
$N \pm 3$ Alternate channel selectivity	C/I_3	Interferer is reference signal at +3 MHz offset ^{1 5 4 6}	—	-48.9	—	dB
		Interferer is reference signal at -3 MHz offset ^{1 5 4 6}	—	-53.8	—	dB
Selectivity to image frequency	C/I_{IM}	Interferer is reference signal at image frequency with 1 MHz precision ^{1 6}	—	-48.3	—	dB
Selectivity to image frequency ± 1 MHz	$C/I_{IM,1}$	Interferer is reference signal at image frequency +1 MHz with 1 MHz precision ^{1 6}	—	-49.9	—	dB
		Interferer is reference signal at image frequency -1 MHz with 1 MHz precision ^{1 6}	—	-46.5	—	dB

Note:

1. 0.017% Bit Error Rate.
2. 0.1% Bit Error Rate.
3. With non-ideal signals as specified in Bluetooth Test Specification RF-PHY.TS.5.0.1 section 4.7.1
4. Desired signal -72 dBm.
5. Desired frequency $2402\text{ MHz} \leq F_c \leq 2480\text{ MHz}$.
6. With allowed exceptions.

3.9 RF Receiver Characteristics for Bluetooth Low Energy in the 2.4 GHz Band 125 kbps Data Rate

Unless otherwise indicated, typical conditions are: $T_A = 25\text{ }^\circ\text{C}$, $V_{DD} = 3.0\text{V}$. RF center frequency 2.45 GHz.

Table 3.9. RF Receiver Characteristics for Bluetooth Low Energy in the 2.4 GHz Band 125 kbps Data Rate

Parameter	Symbol	Test Condition	Min	Typ	Max	Unit
Max usable receiver input level	SAT	Signal is reference signal ¹	—	10	—	dBm
Sensitivity	SENS	Signal is reference signal, 37 byte payload ²	—	-106.7	—	dBm
		Signal is reference signal, 255 byte payload ¹	—	-106.4	—	dBm
		With non-ideal signals ^{3 1}	—	-105.8	—	dBm
Signal to co-channel interferer	C/I_{CC}	(see notes) ^{1 4}	—	0.9	—	dB
$N \pm 1$ Adjacent channel selectivity	C/I_1	Interferer is reference signal at +1 MHz offset ^{1 5 4 6}	—	-13.6	—	dB
		Interferer is reference signal at -1 MHz offset ^{1 5 4 6}	—	-13.4	—	dB
$N \pm 2$ Alternate channel selectivity	C/I_2	Interferer is reference signal at +2 MHz offset ^{1 5 4 6}	—	-52.6	—	dB
		Interferer is reference signal at -2 MHz offset ^{1 5 4 6}	—	-55.8	—	dB
$N \pm 3$ Alternate channel selectivity	C/I_3	Interferer is reference signal at +3 MHz offset ^{1 5 4 6}	—	-53.7	—	dB
		Interferer is reference signal at -3 MHz offset ^{1 5 4 6}	—	-59.0	—	dB
Selectivity to image frequency	C/I_{IM}	Interferer is reference signal at image frequency with 1 MHz precision ^{1 6}	—	-52.7	—	dB
Selectivity to image frequency ± 1 MHz	$C/I_{IM,1}$	Interferer is reference signal at image frequency +1 MHz with 1 MHz precision ^{1 6}	—	-53.7	—	dB
		Interferer is reference signal at image frequency -1 MHz with 1 MHz precision ^{1 6}	—	-52.6	—	dB

Note:

1. 0.017% Bit Error Rate.
2. 0.1% Bit Error Rate.
3. With non-ideal signals as specified in Bluetooth Test Specification RF-PHY.TS.5.0.1 section 4.7.1
4. Desired signal -79 dBm.
5. Desired frequency $2402\text{ MHz} \leq F_c \leq 2480\text{ MHz}$.
6. With allowed exceptions.

3.10 Non-Volatile Configuration Storage

Table 3.10. Non-volatile Configuration Storage

Parameter	Symbol	Test Condition	Min	Typ	Max	Unit
Supply voltage during update	VFLASH		1.71	—	3.8	V

3.11 High-Frequency Crystal

Table 3.11. High-Frequency Crystal

Parameter	Symbol	Test Condition	Min	Typ	Max	Unit
Crystal frequency	f_{HFXTAL}		—	38.4	—	MHz
Initial calibrated accuracy	$\text{ACC}_{\text{HFXTAL}}$		-10	+/-5	10	ppm
Temperature drift	$\text{DRIFT}_{\text{HFXTAL}}$	Across specified temperature range	-20	—	20	ppm

Not Recommended for New Designs

3.12 GPIO Pins

Unless otherwise indicated, typical conditions are: VDD = 3.0 V.

Table 3.12. GPIO Pins

Parameter	Symbol	Test Condition	Min	Typ	Max	Unit
Leakage current	I _{LEAK_IO}	MODEx = DISABLED, VDD = 3.0 V	—	2.5	—	nA
Input low voltage ¹	V _{IL}	Any GPIO pin	—	—	0.3 * VDD	V
		RESETn	—	—	0.3 * DVDD	V
Input high voltage ¹	V _{IH}	Any GPIO pin	0.7 * VDD	—	—	V
		RESETn	0.7 * DVDD	—	—	V
Hysteresis of input voltage	V _{HYS}	Any GPIO pin	0.05 * VDD	—	—	V
		RESETn	0.05 * DVDD	—	—	V
Output low voltage	V _{OL}	Sinking 20mA, VDD = 3.0 V	—	—	0.2 * VDD	V
		Sinking 8mA, VDD = 1.62 V	—	—	0.4 * VDD	V
Output high voltage	V _{OH}	Sourcing 20mA, VDD = 3.0 V	0.8 * VDD	—	—	V
		Sourcing 8mA, VDD = 1.62 V	0.6 * VDD	—	—	V
GPIO rise time	T _{GPIO_RISE}	VDD = 3.0V, C _{load} = 50pF, SLEW-RATE = 4, 10% to 90%	—	8.4	—	ns
		VDD = 1.7V, C _{load} = 50pF, SLEW-RATE = 4, 10% to 90%	—	13	—	ns
GPIO fall time	T _{GPIO_FALL}	VDD = 3.0V, C _{load} = 50pF, SLEW-RATE = 4, 90% to 10%	—	7.1	—	ns
		VDD = 1.7V, C _{load} = 50pF, SLEW-RATE = 4, 90% to 10%	—	11.9	—	ns
Pull up/down resistance	R _{PULL}	GPIO pull-up to VDD: MODEn = DISABLE, DOUT=1. GPIO pull-down to VSS: MODEn = WIRE-DORPULLDOWN, DOUT = 0. RESETn pin pull-up to DVDD.	35	44	55	kΩ
Maximum filtered glitch width	T _{GF}	MODE = INPUT, DOUT = 1	—	27	—	ns
Note:						
1. GPIO input thresholds are proportional to the VDD pin. RESETn input thresholds are proportional to the internal DVDD supply, which is generated by the DC-DC converter. DVDD is equal to 1.8 V when DC-DC is active and bypassed to VDD when DC-DC is inactive.						

3.13 Typical Performance Curves

Typical performance curves indicate typical characterized performance under the stated conditions.

3.13.1 Antenna Radiation and Efficiency

Typical BGX220P radiation patterns and efficiency for the on-board chip antenna under optimal operating conditions are plotted in the figures that follow. Antenna gain and radiation patterns have a strong dependence on the size and shape of the application PCB the module is mounted on, as well as on the proximity of any mechanical design to the antenna.

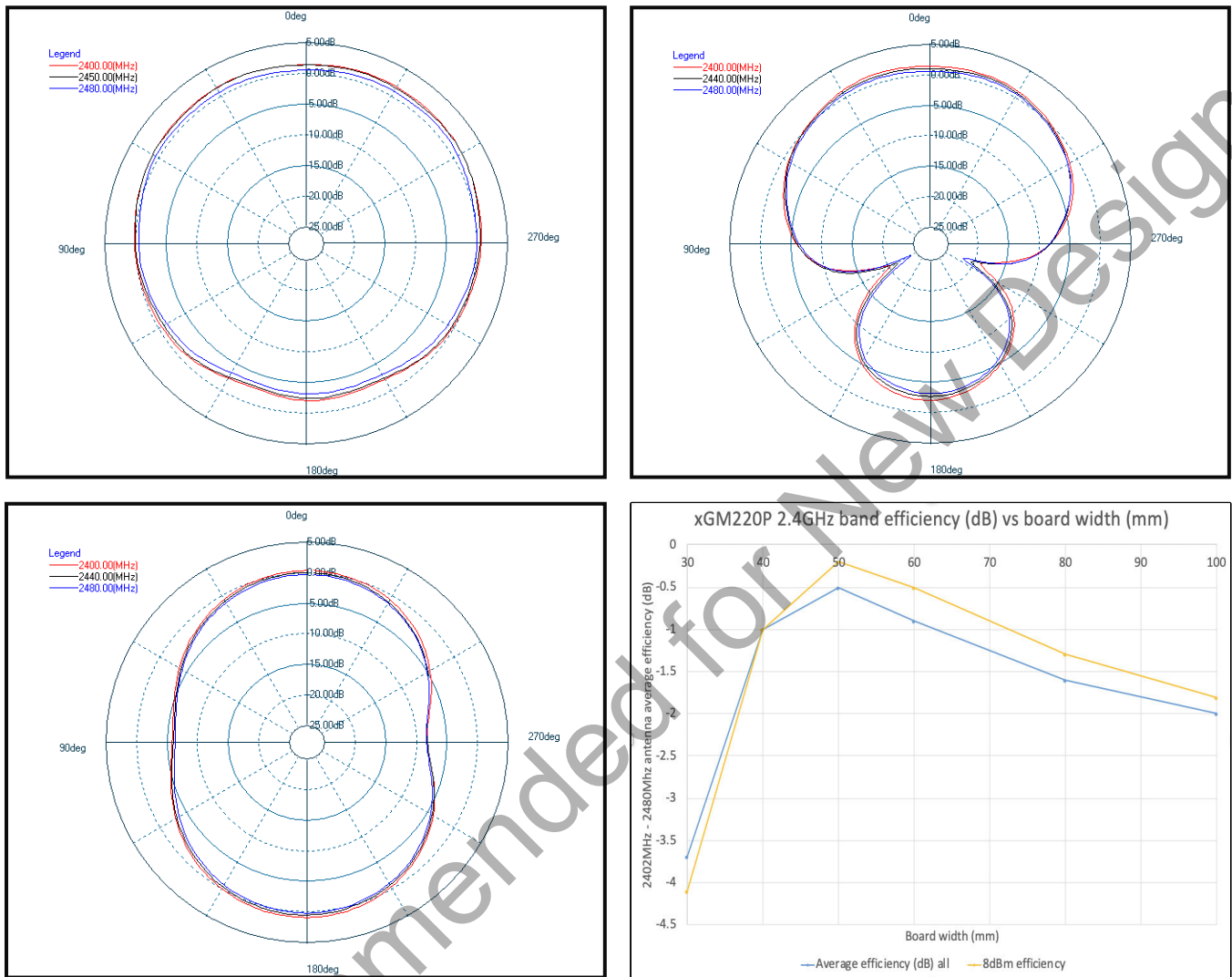

Figure 3.3. Typical 2D Antenna Radiation Patterns and Efficiency

Top Left: Phi 0°, Top Right: Phi 90°, Bottom Left: Theta 90°, Bottom Right: Radiation Efficiency vs Application Board GND Plane Width

4. Reference Diagrams

4.1 Typical Connections

The BGX220P can be controlled over the UART interface as a peripheral to an external host processor. Typical power supply and host interface connections are shown in the figure below.

Note that an external pull-up should not be placed on the reset pin.

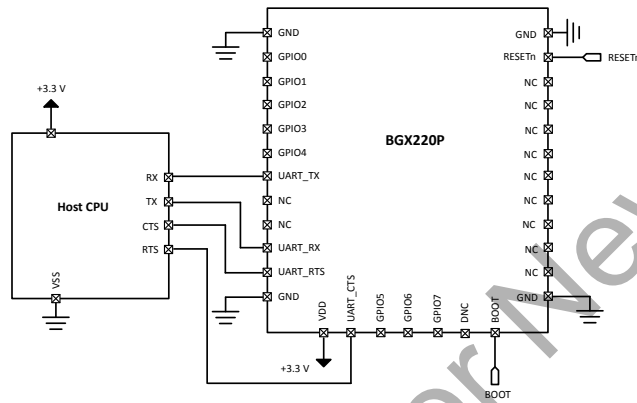

Figure 4.1. Typical Connection Diagram

5. Pin Definitions

5.1 BGX220P Device Pinout

Pin 1 index

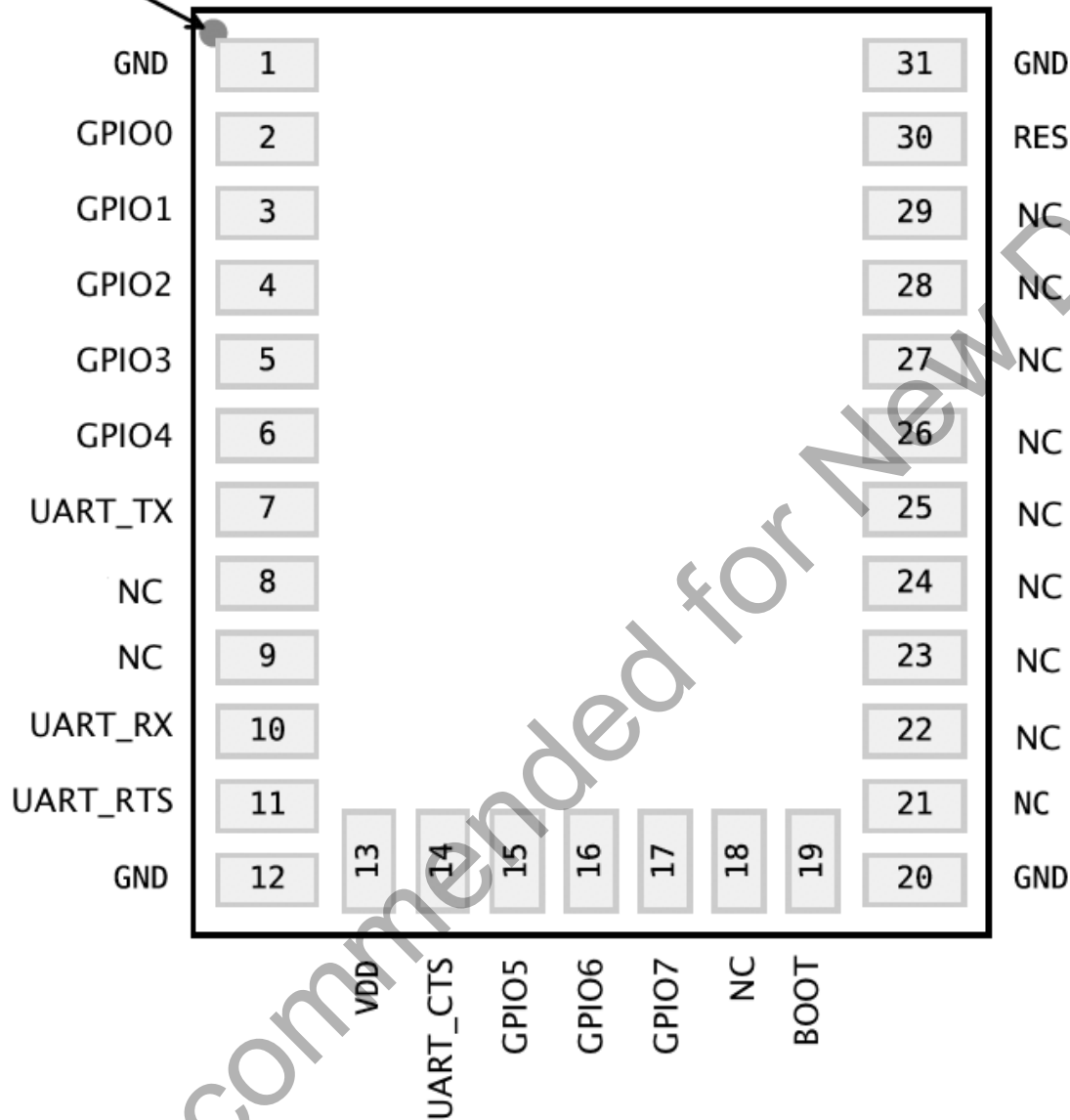

Figure 5.1. BGX220P Device Pinout

Table 5.1. BGX220P Pin Functions

Pin Name	Pin(s)	Description
GND	1	
GPIO0	2	Pin with input/output functionality configured through the command API.
GPIO1	3	Pin with input/output functionality configured through the command API.
GPIO2	4	Pin with input/output functionality configured through the command API.
GPIO3	5	Pin with input/output functionality configured through the command API.

Pin Name	Pin(s)	Description
GPIO4	6	Pin with input/output functionality configured through the command API.
UART_TX	7	Digital output
NC	8	No connect
NC	9	No connect
UART_RX	10	Digital input
UART_RTS	11	Digital output
GND	12	Ground
VDD	13	Power supply
UART_CTS	14	Digital input
GPIO5	15	Pin with input/output functionality configured through the command API.
GPIO6	16	Pin with input/output functionality configured through the command API.
GPIO7	17	Pin with input/output functionality configured through the command API.
NC	18	No connect
BOOT	19	Active-low digital input to force module entrance into DFU bootloader state upon device reset. See command API documentation for functional details.
GND	20	Ground
NC	21	No connect
NC	22	No connect
NC	23	No connect
NC	24	No connect
NC	25	No connect
NC	26	No connect
NC	27	No connect
NC	28	No connect
NC	29	No connect
RESETn	30	Reset Pin
GND	31	Ground

6. Functional overview

6.1 Introduction

The BGX220P creates a Bluetooth 5.2 compliant Bluetooth Low Energy cable replacement interface, facilitating a Bluetooth Low Energy link to a second embedded device or a mobile device. An embedded MCU controls the device and communicates across the Bluetooth Low Energy link through a serial interface and control signals. Parameters stored in non-volatile memory and configurable through the serial interface adjust performance characteristics of the device. Silicon Labs offers iOS and Android mobile libraries for Bluetooth Xpress devices to speed mobile development and simplify communication with the device. This library also controls OTA management, facilitating secure and reliable updates to the device's embedded stack.

This functional overview does not cover each command supported by the command API. The complete command API specification is available at docs.silabs.com.

6.2 Communication Use Cases

The BGX220P family facilitates two types of Bluetooth Low Energy communication links:

- BGX-to-mobile
- BGX-to-BGX

In the BGX-to-mobile communication use case, the BGX220P operates as a peripheral that is discoverable and connectable when configured to that state through either the command API or the pin states driven by the embedded MCU. Using the Xpress mobile library, mobile applications can scan for BGX220P devices, connect, and communicate with the device in both streaming and remote command modes, where the mobile app can execute command API functions remotely.

In the BGX-to-BGX communication use case, one BGX220P must be configured as the central device and one or more other BGX devices should be configured as a peripheral. Devices can be configured at runtime through the command API, or those settings can be saved to non-volatile memory so that each device wakes from power-on or low power states as either a peripheral or central. For more information on advertising and connection options, please see the command API documentation.

6.3 Embedded Interface

The BGX220P family uses an 8-N-1 USART interface for data and flow control signaling. The interface is used both for a raw data streaming interface and a command interface, depending on additional hardware pin configuration.

UART_TX and UART_RX are defined with flow directions relative to the BGX. Bytes sent from the embedded host to the BGX use the UART_RX pin. Bytes sent from the BGX to the embedded host appear on the UART_TX pin.

UART_CTS is a digital input that controls the state of the UART_RTS digital output on the other end of the wireless link. Assertion of a CTS/RTS pair signals that the embedded MCU driving its respective UART_CTS is available to receive bytes.

The baud rate of the BGX220P is a configurable parameter. For information on the process by which a baud rate change gets processed and executed by the device, please see the command API documentation.

State control signals and visual indicators described below can be assigned to any of the GPIO pins through the command API. These settings can be stored in non-volatile memory and take effect during the next power cycle. For information on configuration of standard GPIO and available special function I/O available on the device, please see the command API documentation.

6.4 Command Mode and Streaming Mode

The BGX220P is designed to wake and offer optimized serial interface with hardware flow control. Hardware flow control signaling is disabled by default. When operating in a peripheral role and when flow control signals are monitored, the device may never need to leave streaming mode during operation.

However, when use cases require more advanced runtime configuration, the device can switch to command interface through pin or escape sequence. Commands defined here can control scanning, advertising, connection state, and GPIO settings.

The command interface is also used to configure and store customizable parameters.

Streaming mode can be switched to command mode through an escape sequence of characters if the sequence has been previously saved in the device's configuration. A command can be issued in command mode to switch to streaming mode. Stream mode and command mode entrance can be controlled through a device port pin state, if a pin has been previously defined for that purpose.

6.5 Command API

Each command begins with a command name followed by arguments, and the syntax of each command is defined in the command API documentation.

The command interface saves settings as key-value pairs. These values can be used at runtime to modify the operational state, and they can also be stored in non-volatile memory. Values stored in non-volatile memory function to configure the device's startup/default state.

6.6 GPIO Control

The BGX220P offers 8 GPIO pins. These pins can be configured as state control pins or visual indicator pins. Alternatively, they can be used as general purpose I/O pins. Digital output settings can be set and digital input state can be read through the command interface locally or remotely through the remote command execution using the mobile libraries.

6.7 Device Configuration

Device configuration is handled through the command API, where commands are executed when the serial interface is set to operate in command mode. These commands can also be executed remotely through the mobile library unless prohibited through previous configuration.

Additionally, a device configuration can be generated and saved using Simplicity Studio's Xpress Configurator tool. A generated configuration can be submitted to Silicon Labs through the process defined in that application. Silicon Labs will then validate the configuration request, generate a custom orderable part number, and deliver first article samples for testing. Developers should contact sales representatives for more information about this process. Once first article samples have been validated by the customer, this custom orderable part number can be ordered directly from Silicon Labs.

6.8 Security Features

BGX220P devices communicate with LE secure connections, establishing encrypted communication upon connection.

Device OTA requires an encrypted image signed by Silicon Laboratories. Only firmware developed, signed, and encrypted by Silicon Labs can be bootloaded successfully on the device.

6.9 OTA

The BGX220P supports secure OTA of the embedded stack and the command interface. Images are encrypted and signed by Silicon Laboratories. OTA can be performed through the mobile library APIs. Specific device firmware versions can be selected and programmed through these APIs. See command API documentation for more information.

For information on new functionality including firmware updates to BGX220P, please see docs.silabs.com. BGX220P module OPN firmware will not be updated to include newly released features available through OTA and DFU updates provided by Silicon Labs. Module OPN firmware will only be updated at manufacturing time to provide security-related enhancements.

Contact Silicon Labs technical support for information on customer factory programming options for custom OPN ordering with a specified device firmware version and for customer factory programming options.

6.10 Direct Test Mode Support

The BGX220P's command API offers a command set that configures the device to support the Direct Test Mode (DTM) protocol as defined in the Bluetooth Core Specification Version 4.2, Volume 6, part F.

See the command API for information about commands to support specific DTM test procedures.

7. Design Guidelines

7.1 Layout and Placement

For optimal performance of the BGX220P,

- Place the module aligned to the edge of the application PCB, as illustrated in the figures below.
- Leave the antenna clearance area void of any traces, components, or copper on all layers of the application PCB.
- Connect all ground pads directly to a solid ground plane.
- Place the ground vias as close to the ground pads as possible.
- Do not place plastic or any other dielectric material in contact with the antenna.

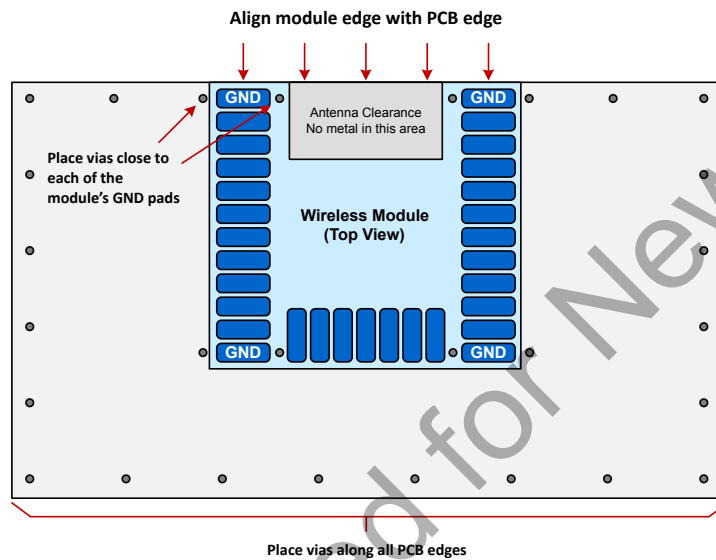

Figure 7.1. Recommended Layout for BGX220P

The figure below illustrates layout scenarios that will lead to severely degraded RF performance for the module.

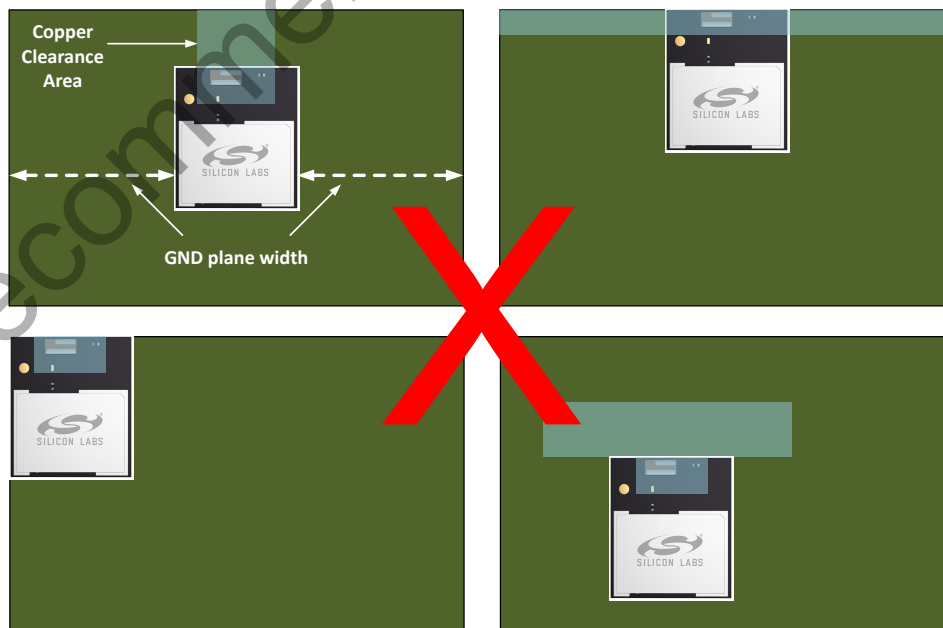

Figure 7.2. Non-Optimal Layout Examples

The width of the GND plane to the sides the module will impact the efficiency of the on-board chip antenna. To achieve optimal performance, a GND plane width of 50 mm is recommended. See [3.13.1 Antenna Radiation and Efficiency](#) for reference.

7.2 Proximity to Other Materials

Avoid placing plastic or any other dielectric material in close proximity to the antenna.

Any metallic objects in close proximity to the antenna will prevent the antenna from radiating freely. The minimum recommended distance of metallic and/or conductive objects is 10 mm in any direction from the antenna except in the directions of the application PCB ground planes.

7.3 Proximity to Human Body

Placing the module in contact with or very close to the human body will negatively impact antenna efficiency and reduce range.

Not Recommended for New Designs

8. Package Specifications

8.1 Dimensions

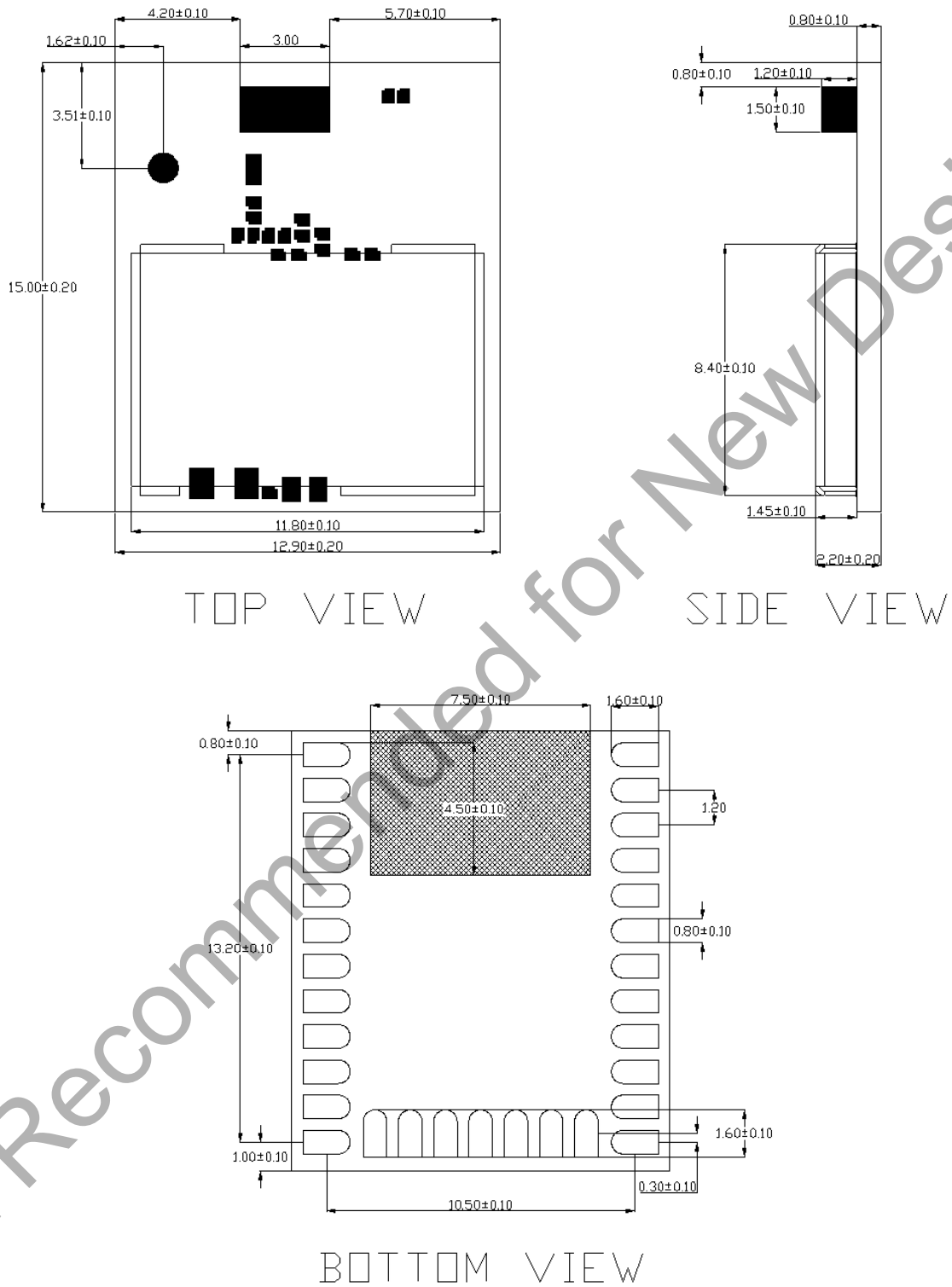

Figure 8.1. Module Dimensions

8.3 Package Marking

The figure below shows the module markings engraved on the RF shield.

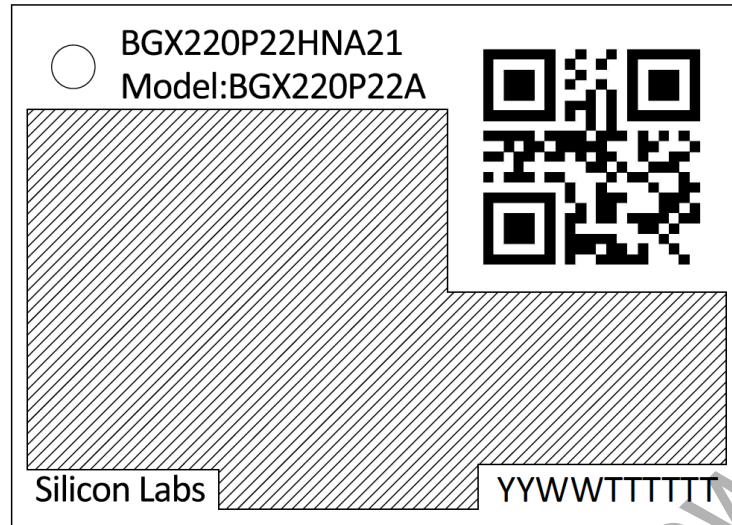

Figure 8.3. BGX220P Top Marking

Mark Description

The package marking consists of:

- BGX220Pxxxxxx - Part number designation
- Model: BGX220Pxxx - Model number designation
- QR Code: YYWWMMABCDE
 - YY – Last two digits of the assembly year.
 - WW – Two-digit workweek when the device was assembled.
 - MMABCDE – Silicon Labs unit code
- YYWWTTTTTT
 - YY – Last two digits of the assembly year.
 - WW – Two-digit workweek when the device was assembled.
 - TTTTTT – Manufacturing trace code. The first letter is the device revision.
- Certification marks such as the CE logo, FCC and IC IDs, etc will be engraved on the grayed out area, according to regulatory body requirements.

9. Soldering Recommendations

It is recommended that final PCB assembly of the BGX220P follows the industry standard as identified by the Institute for Printed Circuits (IPC). This product is assembled in compliance with the J-STD-001 requirements and the guidelines of IPC-AJ-820. Surface mounting of this product by the end user is recommended to follow IPC-A-610 to meet or exceed class 2 requirements.

CLASS 1 General Electronic Products

Includes products suitable for applications where the major requirement is function of the completed assembly.

CLASS 2 Dedicated Service Electronic Products

Includes products where continued performance and extended life is required, and for which uninterrupted service is desired but not critical. Typically the end-use environment would not cause failures.

CLASS 3 High Performance/Harsh Environment Electronic Products

Includes products where continued high performance or performance-on-demand is critical, equipment downtime cannot be tolerated, end-use environment may be uncommonly harsh, and the equipment must function when required, such as life support or other critical systems.

Not Recommended for New Designs

10. Tape and Reel

BGX220P modules are delivered to the customer in cut tape (100 pcs) or reel (1000 pcs) packaging with the dimensions below. All dimensions are given in mm unless otherwise indicated.

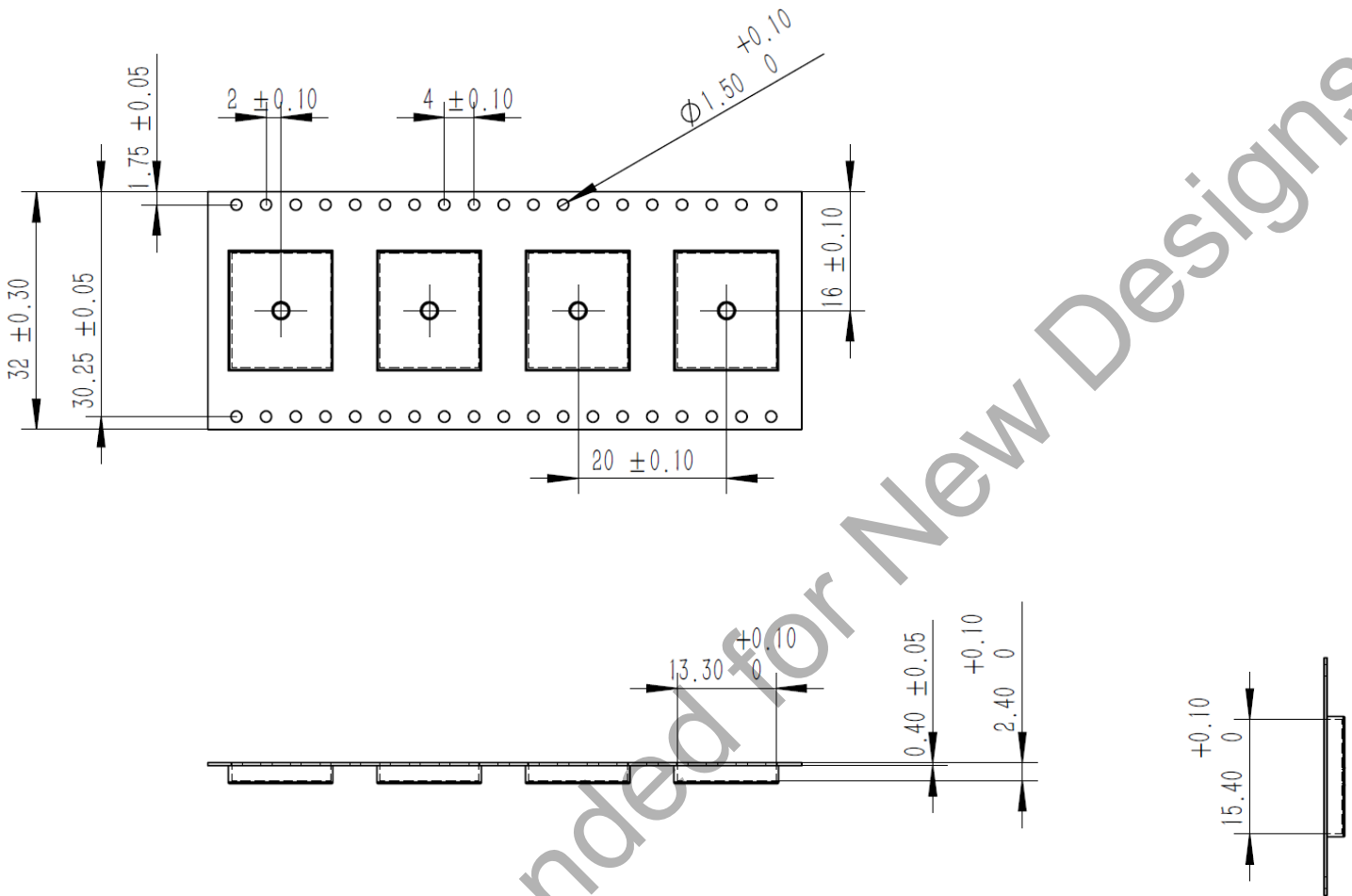

Figure 10.1. Carrier Tape Dimensions

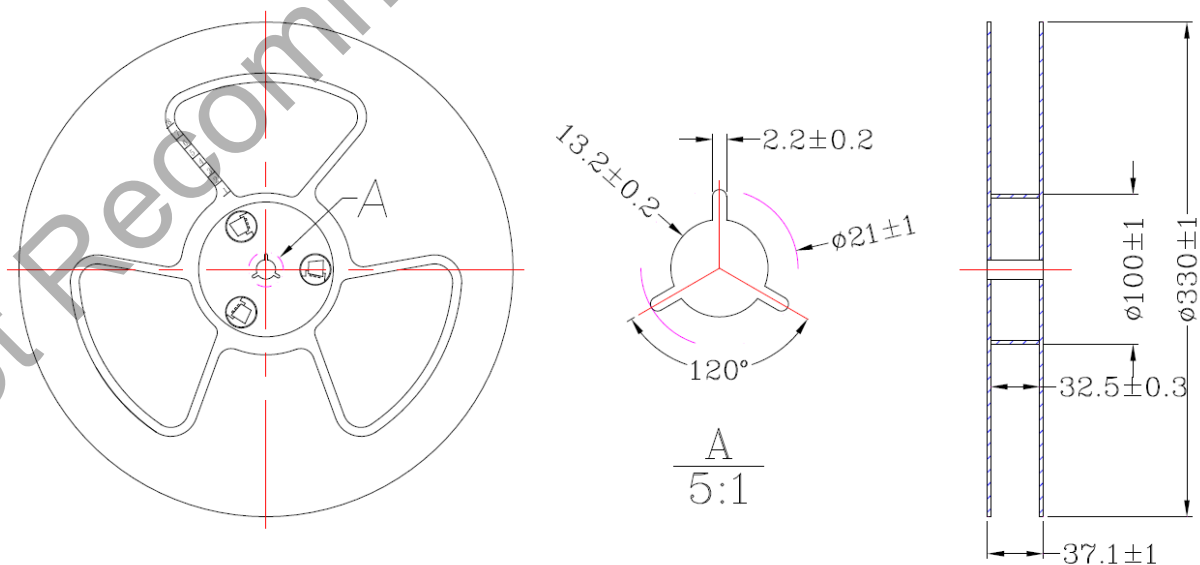

Figure 10.2. Reel Dimensions

11. Certifications

This section details the regulatory certification status of the module in various regions.

The address for the module manufacturer and certification applicant is:

SILICON LABORATORIES FINLAND OY
Alberga Business Park, Bertel Jungin aukio 3,
02600 Espoo, Finland

11.1 Qualified Antennas

BGX220P modules have been tested and certified with the on-board chip antenna. Performance characteristics for the chip antenna are presented in [Table 2.1 Antenna Efficiency and Peak Gain on page 6](#) and [3.13.1 Antenna Radiation and Efficiency](#).

11.2 EU - CE

The BGX220P modules are in conformity with the essential requirements and other relevant requirements of the Radio Equipment Directive (RED) (2014/53/EU).

Please note that every application using the BGX220P module will need to perform the radio EMC tests on the end product, according to EN 301 489-17.

It is ultimately the responsibility of the manufacturer to ensure the compliance of the end-product as a whole. The specific product assembly may have an impact to RF radiated characteristics, and manufacturers should carefully consider RF radiated testing with the end-product assembly.

A formal Declaration of Conformity (DoC) is available at the product web page which is reachable starting from <https://www.silabs.com/>.

11.3 USA - FCC

This device complies with Part 15 of the FCC Rules when operating with the embedded antenna. Operation is subject to the following two conditions:

1. This device may not cause harmful interference, and
2. This device must accept any interference received, including interference that may cause undesirable operation.

Any changes or modifications not expressly approved by Silicon Labs could void the user's authority to operate the equipment.

FCC RF Radiation Exposure Statement

This equipment complies with FCC radiation exposure limits set forth for an uncontrolled environment. End users must follow the specific operating instructions for satisfying RF exposure compliance.

This transmitter meets the Mobile requirements at a distance of 20 cm and above from the human body, in accordance to the limit(s) exposed in the RF Exposure Analysis.

This transmitter also meets the Portable requirements at distances equal or above those listed for convenience in [Table 11.1 Minimum Separation Distances for SAR Evaluation Exemption on page 35](#).

This transmitter must not be co-located or operating in conjunction with any other antenna or transmitter except in accordance with FCC multi-transmitter product procedures.

OEM Responsibilities to comply with FCC Regulations

This module has been tested for compliance to FCC Part 15.

OEM integrators are responsible for testing their end-product for any additional compliance requirements needed with this module installed (for example, digital device emissions, PC peripheral requirements, etc.). Additionally, investigative measurements and spot checking are strongly recommended to verify that the full system compliance is maintained when the module is integrated, in accordance to the "Host Product Testing Guidance" in FCC's KDB 996369 D04 Module Integration Guide V01.

- **General Considerations**

This transmitter module is tested as a subsystem and its certification does not cover the FCC Part 15 Subpart B (unintentional radiator) rule requirement. However, such requirement is typically applicable to the final host. Thus, the final host will still need to be re-assessed for compliance to this portion of rule requirements, if applicable.

- **Manual Information to the End User**

The OEM integrator has to be aware not to provide information to the end-user regarding how to install or remove this RF module in the user's manual of the end product which integrates this module.

The end user manual shall include all required regulatory information/warnings as shown in this manual.

- **OEM/Host Manufacturer Responsibilities**

OEM / Host manufacturers are ultimately responsible for the compliance of the Host and Module. The final product must be reassessed against all the essential requirements of the FCC rule such as FCC Part 15 Subpart B before it can be placed on the US market. This includes reassessing the transmitter module for compliance with the Radio and EMF essential requirements of the FCC rules. This module must not be incorporated into any other device or system without retesting for compliance as multi-radio and combined equipment.

Separation

- To meet the SAR exemption for portable conditions, the minimum separation distance indicated in [Table 11.1 Minimum Separation Distances for SAR Evaluation Exemption on page 35](#) must be maintained between the human body and the radiator (antenna) at all times.
- This transmitter module is tested in a standalone mobile RF exposure condition, and in case of any co-located radio transmitter being allowed to transmit simultaneously, or in case of portable use at closer distances from the human body than those allowing the exceptions rules to be applied, a separate additional SAR evaluation will be required, ultimately leading to a Class II Permissive Change, or more rarely to a new grant.
- **Important Note:** In the event that these conditions cannot be met, then for the FCC authorization to remain valid the final product will have to undergo additional testing to evaluate the RF exposure, and a permissive change will have to be applied. The evaluation (SAR) is in the responsibility of the end-product's manufacturer, as well as the permissive change that can be carried out with the help of the customer's own Telecommunication Certification Body typically acting as the grant holder's agent.

End Product Labeling

BGX220P modules are labeled with their own FCC ID. If the FCC ID is not visible when the module is installed inside another device, then the outside of the device into which the module is installed must also display a label referring to the enclosed module. In that case, the final end product must be labeled in a visible area with the following:

"Contains Transmitter Module FCC ID: QOQ-GM220P"

Or

"Contains FCC ID: QOQ-GM220P"

The OEM integrator has to be aware not to provide information to the end user regarding how to install or remove this RF module or change RF related parameters in the user manual of the end product.

As long as all conditions above are met, further transmitter test will not be required. However, the OEM integrator is still responsible for testing their end-product for any additional compliance requirements required with this module installed.

Class B Device Notice

Note: This equipment has been tested and found to comply with the limits for a Class B digital device, pursuant to part 15 of the FCC Rules. These limits are designed to provide reasonable protection against harmful interference in a residential installation. This equipment generates, uses, and can radiate radio frequency energy and, if not installed and used in accordance with the instructions, may cause harmful interference to radio communications. However, there is no guarantee that interference will not occur in a particular installation. If this equipment does cause harmful interference to radio or television reception, which can be determined by turning the equipment off and on, the user is encouraged to try to correct the interference by one or more of the following measures:

- Reorient or relocate the receiving antenna.
- Increase the separation between the equipment and receiver.
- Connect the equipment into an outlet on a circuit different from that to which the receiver is connected.
- Consult the dealer or an experienced radio / TV technician for help.

Not Recommended for New Designs

11.4 ISED Canada

ISED

This radio transmitter (IC: 5123A-GM220P) has been approved by *Innovation, Science and Economic Development Canada (ISED Canada, formerly Industry Canada)* to operate with the embedded antenna and with the antenna type(s) listed in , with the maximum permissible gain indicated. Antenna types not included in this list, having a gain greater than the maximum gain listed, are strictly prohibited for use with this device.

This device complies with ISED's license-exempt RSS standards. Operation is subject to the following two conditions:

1. This device may not cause interference; and
2. This device must accept any interference, including interference that may cause undesired operation of the device.

RF Exposure Statement

Exception from routine SAR evaluation limits are given in RSS-102 Issue 5.

The module meets the given requirements when the minimum separation distance to human body is as indicated in [Table 11.1 Minimum Separation Distances for SAR Evaluation Exemption on page 35](#).

RF exposure or SAR evaluation is not required when the separation distances from the human body are equal or above those stated in [Table 11.1 Minimum Separation Distances for SAR Evaluation Exemption on page 35](#). If the separation distance is less than stated in [Table 11.1 Minimum Separation Distances for SAR Evaluation Exemption on page 35](#), the OEM integrator is responsible for evaluating the SAR.

OEM Responsibilities to comply with IC Regulations

The module has been certified for integration into products only by OEM integrators under the following conditions:

- The antenna must be installed such that a minimum separation distance as stated above is maintained between the radiator (antenna) and all persons at all times.
- The transmitter module must not be co-located or operating in conjunction with any other antenna or transmitter.

Important Note: In the event that these conditions cannot be met, the final product will have to undergo additional testing to evaluate the RF exposure in order for the ISED authorization to remain valid, and a permissive change will have to be applied with the help of the customer's own Telecommunication Certification Body typically acting as the certificate holder's agent.

End Product Labeling

The BGX220P module is labeled with its own IC ID. If the IC ID is not visible when the module is installed inside another device, then the outside of the device into which the module is installed must also display a label referring to the enclosed module. In that case, the final end product must be labeled in a visible area with the following:

"Contains Transmitter Module IC: 5123A-GM220P"

or

"Contains IC: 5123A-GM220P"

The OEM integrator has to be aware not to provide information to the end user regarding how to install or remove this RF module or change RF related parameters in the user manual of the end product.

As long as all the conditions above are met, further transmitter testing will not be required. However, the OEM integrator is still responsible for testing their end-product for any additional compliance requirements required with this module installed (for example, digital device emissions, PC peripheral requirements, etc.).

CAN ICES-003 (B)

This Class B digital apparatus complies with Canadian ICES-003.

ISED (Français)

Le présent émetteur radio (IC: 5123A-GM220P) a été approuvé par Innovation, Sciences et Développement Économique Canada (ISED Canada, anciennement Industrie Canada) pour fonctionner avec l'antenne intégrée et le ou les types d'antenne énumérés à la section , avec le gain maximal admissible indiqué. Les types d'antenne non inclus dans cette liste, ayant un gain supérieur au gain maximal indiqué, sont strictement interdits d'utilisation avec cet appareil. .

Ce composant est conforme aux normes RSS, exonérées de licence d'ISED. Son mode de fonctionnement est soumis aux deux conditions suivantes:

1. Ce composant ne doit pas générer d'interférences.
2. Ce composant doit pouvoir être soumis à tout type de perturbation y compris celle pouvant nuire à son bon fonctionnement.

Déclaration d'exposition RF

L'exception tirée des limites courantes d'évaluation SAR est donnée dans le document RSS-102 Issue 5.

Les modèles BGX220P respectent les exigences d'exemption prévues lorsque la distance de séparation minimale entre le(s) antenne(s) et le corps humain est conforme aux valeurs indiquées dans le [Table 11.1 Minimum Separation Distances for SAR Evaluation Exemption on page 35](#).

La déclaration d'exposition RF ou l'évaluation DAS n'est pas nécessaire lorsque la distance de séparation est identique ou supérieure à celle indiquée ci-dessus. Si la distance de séparation est inférieure à celle mentionnées plus haut, il incombe à l'intégrateur OEM de procéder à une évaluation DAS.

La déclaration d'exposition RF ou l'évaluation SAR n'est pas nécessaire lorsque la distance de séparation est identique ou supérieure à celle indiquée ci-dessus. Si la distance de séparation est inférieure à celle mentionnées plus haut, il incombe à l'intégrateur OEM de procéder à une évaluation SAR.

Responsabilités des OEM pour une mise en conformité avec le Règlement du Circuit Intégré

Le module a été approuvé pour l'intégration dans des produits finaux exclusivement réalisés par des OEM sous les conditions suivantes:

- L'antenne doit être installée de sorte qu'une distance de séparation minimale indiquée ci-dessus soit maintenue entre le radiateur (antenne) et toutes les personnes avoisinante, ce à tout moment.
- Le module émetteur ne doit pas être localisé ou fonctionner avec une autre antenne ou un autre transmetteur que celle indiquée plus haut.

Tant que les deux conditions ci-dessus sont respectées, il n'est pas nécessaire de tester ce transmetteur de façon plus poussée. Cependant, il incombe à l'intégrateur OEM de s'assurer de la bonne conformité du produit fini avec les autres normes auxquelles il pourrait être soumis de fait de l'utilisation de ce module (par exemple, les émissions des périphériques numériques, les exigences de périphériques PC, etc.).

Remarque Importante: Dans le cas où ces conditions ne peuvent être satisfaites (pour certaines configurations ou co-implantation avec un autre émetteur), l'autorisation ISED n'est plus considérée comme valide et le numéro d'identification ID IC ne peut pas être apposé sur le produit final. Dans ces circonstances, l'intégrateur OEM sera responsable de la réévaluation du produit final (y compris le transmetteur) et de l'obtention d'une autorisation ISED distincte.

Étiquetage des produits finis

Les modules BGX220P sont étiquetés avec leur propre ID IC. Si l'ID IC n'est pas visible lorsque le module est intégré au sein d'un autre produit, cet autre produit dans lequel le module est installé devra porter une étiquette faisant apparaître les référence du module intégré. Dans un tel cas, sur le produit final doit se trouver une étiquette aisément lisible sur laquelle figurent les informations suivantes:

“Contient le module transmetteur: 5123A-GM220P ”

or

“Contient le circuit: 5123A-GM220P”

L'intégrateur OEM doit être conscient qu'il ne doit pas fournir, dans le manuel d'utilisation, d'informations relatives à la façon d'installer ou de d'enlever ce module RF ainsi que sur la procédure à suivre pour modifier les paramètres liés à la radio.

CAN ICES-003 (B)

Cet appareil numérique de classe B est conforme à la norme canadienne ICES-003.

11.5 Proximity to Human Body

When using the module in an application where the radio is located close to the human body, the human RF exposure must be evaluated. FCC, ISED, and CE all have different standards for evaluating the RF exposure, and because of this, each standard requires a different minimum separation distance between the module and human body. Certification of BGX220P allows for the minimum separation distances detailed in the table below in portable use cases (less than 20 cm from human body). The module is approved for the mobile use case (more than 20 cm) without any need for RF exposure evaluation.

Table 11.1. Minimum Separation Distances for SAR Evaluation Exemption

Certification	BGX220P22A
FCC	Bluetooth LE: 0 mm
ISED	Bluetooth LE: 14 mm
CE	The RF exposure must always be evaluated using the end-product when transmitting with power levels higher than 20 mW (13 dBm).

For FCC and ISED, using the module in end-products where the separation distance from the human body is smaller than that listed above is allowed but requires evaluation of the RF exposure in the final assembly and applying for a *Class 2 Permissive Change* or *Change of ID* to be applied to the existing FCC/ISED approvals of the module. For CE, RF exposure must be evaluated using the end-product in all cases when transmitting at more than the power level indicated in the table.

Note: Placing the module in touch or very close to the human body will have a negative impact on the efficiency of the antenna thus a reduced range is to be expected.

Not Recommended for New Designs

11.6 Japan - MIC

The BGX220P22A are certified in Japan with certification number 020-200011.

It is the end-product manufacturer's responsibility to ensure that the module is configured to meet the limits documented in the formal certification test report available at <https://www.silabs.com/>. If needed, refer to the API reference manual(s) to learn how to configure the maximum RF TX power for the normal operations.

Since September 1, 2014 it is allowed (and highly recommended) that a manufacturer who integrates a radio module in their host equipment places the certification mark and certification number on the outside of the host equipment. This combination of mark and number, and their relative placement, is depicted in figure 11.1, and depending on the size of the module it might also appear on the top shield markings of the radio module. The certification mark and certification number must be placed close to the text in the Japanese language which is provided below. This change in the Radio Law has been made in order to enable users of the combination of host and radio module to verify if they are actually using a radio device which is approved for use in Japan

Certification Text to be Placed on the Outside Surface of the Host Equipment:

当該機器には電波法に基づく、技術基準適合証明等を受けた特定無線設備を装着している。

Translation of the text:

"This equipment contains specified radio equipment that has been certified to the Technical Regulation Conformity Certification under the Radio Law."

The "Giteki" marking shown in the figures below must be affixed to an easily noticeable section of the specified radio equipment.

Note that additional information may be required if the device is also subject to a telecom approval.



Figure 11.1. GITEKI Mark and ID

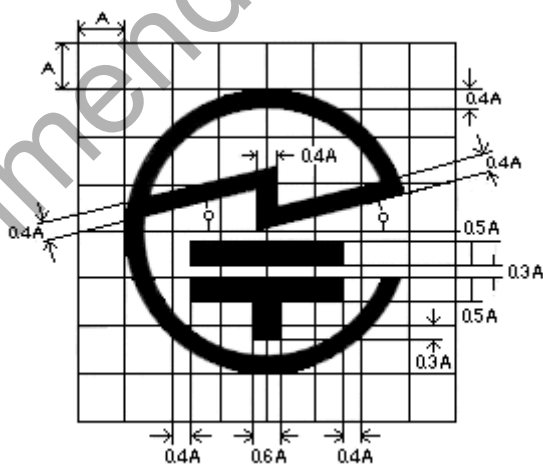

Figure 11.2. GITEKI Mark

11.7 South Korea - KC

The BGX220P22A modules have a RF certification for import and use in South-Korea.

Certification number is: R-R-BGT-GM220P

When integrating the RF-certified module, an end-product is exempted from doing the RF emission testing, as long as the recommended design guidance is followed, and the approved antennas are used.

EMC testing, and any other relevant test, might still be required for full compliance.

11.8 Bluetooth Qualification

The BGX220P modules come with a pre-qualified RF-PHY component having Declaration ID of D044525 and QDID of 146980.

This component can be combined with the latest Link Layer and Host pre-qualified components when in the process of qualifying the end-product via the SIG's Launch Studio.

Not Recommended for New Designs

12. Revision History

Revision 1.0

July, 2020

- Initial release.

Not Recommended for New Designs

Silicon Labs

Simplicity Studio™4



Simplicity Studio

One-click access to MCU and wireless tools, documentation, software, source code libraries & more. Available for Windows, Mac and Linux!



IoT Portfolio
www.silabs.com/IoT



SW/HW
www.silabs.com/simplicity



Quality
www.silabs.com/quality



Support and Community
community.silabs.com

Disclaimer

Silicon Labs intends to provide customers with the latest, accurate, and in-depth documentation of all peripherals and modules available for system and software implementers using or intending to use the Silicon Labs products. Characterization data, available modules and peripherals, memory sizes and memory addresses refer to each specific device, and "Typical" parameters provided can and do vary in different applications. Application examples described herein are for illustrative purposes only. Silicon Labs reserves the right to make changes without further notice to the product information, specifications, and descriptions herein, and does not give warranties as to the accuracy or completeness of the included information. Without prior notification, Silicon Labs may update product firmware during the manufacturing process for security or reliability reasons. Such changes will not alter the specifications or the performance of the product. Silicon Labs shall have no liability for the consequences of use of the information supplied in this document. This document does not imply or expressly grant any license to design or fabricate any integrated circuits. The products are not designed or authorized to be used within any FDA Class III devices, applications for which FDA premarket approval is required, or Life Support Systems without the specific written consent of Silicon Labs. A "Life Support System" is any product or system intended to support or sustain life and/or health, which, if it fails, can be reasonably expected to result in significant personal injury or death. Silicon Labs products are not designed or authorized for military applications. Silicon Labs products shall under no circumstances be used in weapons of mass destruction including (but not limited to) nuclear, biological or chemical weapons, or missiles capable of delivering such weapons. Silicon Labs disclaims all express and implied warranties and shall not be responsible or liable for any injuries or damages related to use of a Silicon Labs product in such unauthorized applications.

Trademark Information

Silicon Laboratories Inc.®, Silicon Laboratories®, Silicon Labs®, SiLabs® and the Silicon Labs logo®, Bluegiga®, Bluegiga Logo®, ClockBuilder®, CMEMS®, DSPLL®, EFM®, EFM32®, EFR®, Ember®, Energy Micro, Energy Micro logo and combinations thereof, "the world's most energy friendly microcontrollers", Ember®, EZLink®, EZRadio®, EZRadioPRO®, Gecko®, Gecko OS, Gecko OS Studio, ISOModem®, Precision32®, ProSLIC®, Simplicity Studio®, SiPHY®, Telegesis, the Telegesis Logo®, USBXpress®, Zentri, the Zentri logo and Zentri DMS, Z-Wave®, and others are trademarks or registered trademarks of Silicon Labs. ARM, CORTEX, Cortex-M3 and THUMB are trademarks or registered trademarks of ARM Holdings. Keil is a registered trademark of ARM Limited. Wi-Fi is a registered trademark of the Wi-Fi Alliance. All other products or brand names mentioned herein are trademarks of their respective holders.



Silicon Laboratories Inc.
400 West Cesar Chavez
Austin, TX 78701
USA

<http://www.silabs.com>