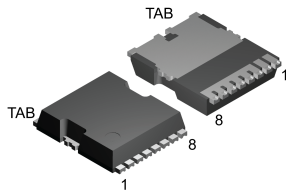
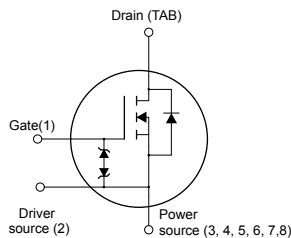

## N-channel 650 V, 53 mΩ typ., 55 A MDmesh DM6 Power MOSFET in a TO-LL package

**TO-LL type A2**

N-chG1DS2PS345678DTABZ

**Product status link**
[STO68N65DM6](#)
**Product summary**

<b>Order code</b>	STO68N65DM6
<b>Marking</b>	68N65DM6
<b>Package</b>	TO-LL type A2
<b>Packing</b>	Tape and reel

### Features

Order code	V <sub>DS</sub>	R <sub>DS(on)</sub> max.	I <sub>D</sub>
STO68N65DM6	650 V	65 mΩ	55 A

- Fast-recovery body diode
- Lower R<sub>DS(on)</sub> per area vs previous generation
- Low gate charge, input capacitance and resistance
- 100% avalanche tested
- Extremely high dv/dt ruggedness
- Zener-protected
- Excellent switching performance thanks to the extra driving source pin

### Applications

- Switching applications

### Description

This high-voltage N-channel Power MOSFET is part of the MDmesh DM6 fast-recovery diode series. Compared with the previous MDmesh fast generation, DM6 combines very low recovery charge (Q<sub>rr</sub>), recovery time (t<sub>rr</sub>) and excellent improvement in R<sub>DS(on)</sub> per area with one of the most effective switching behaviors available in the market for the most demanding high-efficiency bridge topologies and ZVS phase-shift converters.

# 1 Electrical ratings

**Table 1. Absolute maximum ratings**

Symbol	Parameter	Value	Unit
$V_{GS}$	Gate-source voltage	$\pm 25$	V
$I_D^{(1)}$	Drain current (continuous) at $T_C = 25\text{ }^\circ\text{C}$	55	A
	Drain current (continuous) at $T_C = 100\text{ }^\circ\text{C}$	35	
$I_{DM}^{(2)}$	Drain current (pulsed)	172	A
$P_{TOT}$	Total power dissipation at $T_C = 25\text{ }^\circ\text{C}$	240	W
$dv/dt^{(3)}$	Peak diode recovery voltage slope	100	V/ns
$di/dt^{(3)}$	Peak diode recovery current slope	1000	A/ $\mu\text{s}$
$dv/dt^{(4)}$	MOSFET $dv/dt$ ruggedness	100	V/ns
$T_{stg}$	Storage temperature range	-55 to 150	$^\circ\text{C}$
$T_J$	Operating junction temperature range		$^\circ\text{C}$

1. Referred to TO-247 package.
2. Pulse width is limited by safe operating area.
3.  $I_{SD} \leq 55\text{ A}$ ,  $V_{DS} (\text{peak}) < V_{(BR)DSS}$ ,  $V_{DD} = 400\text{ V}$ .
4.  $V_{DS} \leq 520\text{ V}$ .

**Table 2. Thermal data**

Symbol	Parameter	Value	Unit
$R_{thJC}$	Thermal resistance, junction-to-case	0.52	$^\circ\text{C/W}$
$R_{thJB}$	Thermal resistance, junction-to-board <sup>(1)</sup>	43	$^\circ\text{C/W}$
	Thermal resistance, junction-to-board <sup>(2)</sup>	22	

1. When mounted on 1 inch<sup>2</sup> FR-4 pcb, standard footprint 2 Oz copper board.
2. When mounted on 40x40mm FR-4 pcb, 6 cm<sup>2</sup> 2 Oz copper board.

**Table 3. Avalanche characteristics**

Symbol	Parameter	Value	Unit
$I_{AR}$	Avalanche current, repetitive or not repetitive (pulse width limited by $T_J$ max.)	9	A
$E_{AS}$	Single pulse avalanche energy (starting $T_J = 25\text{ }^\circ\text{C}$ , $I_D = I_{AR}$ , $V_{DD} = 50\text{ V}$ )	930	mJ

## 2 Electrical characteristics

$T_C = 25\text{ °C}$  unless otherwise specified.

**Table 4. On /off-states**

Symbol	Parameter	Test conditions	Min.	Typ.	Max.	Unit
$V_{(BR)DSS}$	Drain-source breakdown voltage	$V_{GS} = 0\text{ V}, I_D = 1\text{ mA}$	650			V
$I_{DSS}$	Zero-gate voltage drain current	$V_{GS} = 0\text{ V}, V_{DS} = 650\text{ V}$			1	$\mu\text{A}$
		$V_{GS} = 0\text{ V}, V_{DS} = 650\text{ V}, T_C = 125\text{ °C}^{(1)}$			100	
$I_{GSS}$	Gate-body leakage current	$V_{DS} = 0\text{ V}, V_{GS} = \pm 25\text{ V}$			$\pm 5$	$\mu\text{A}$
$V_{GS(th)}$	Gate threshold voltage	$V_{DS} = V_{GS}, I_D = 250\text{ }\mu\text{A}$	3.25	4.00	4.75	V
$R_{DS(on)}$	Static drain-source on-resistance	$V_{GS} = 10\text{ V}, I_D = 27.5\text{ A}$		53	65	m $\Omega$

1. Defined by design, not subject to production test.

**Table 5. Dynamic**

Symbol	Parameter	Test conditions	Min.	Typ.	Max.	Unit
$C_{iss}$	Input capacitance	$V_{GS} = 0\text{ V}, V_{DS} = 100\text{ V}, f = 1\text{ MHz}$	-	3528	-	pF
$C_{oss}$	Output capacitance		-	258	-	pF
$C_{rSS}$	Reverse transfer capacitance		-	1.5	-	pF
$C_{oss\text{ eq.}}^{(1)}$	Equivalent output capacitance	$V_{GS} = 0\text{ V}, V_{DS} = 0\text{ to }520\text{ V}$	-	609	-	pF
$R_G$	Intrinsic gate resistance	$f = 1\text{ MHz}$ open drain	-	1.25	-	$\Omega$
$Q_g$	Total gate charge	$V_{DD} = 520\text{ V}, I_D = 48\text{ A}, V_{GS} = 0\text{ to }10\text{ V}$ (see Figure 14. Test circuit for gate charge behavior)	-	80	-	nC
$Q_{gs}$	Gate-source charge		-	21.5	-	nC
$Q_{gd}$	Gate-drain charge		-	35	-	nC

1.  $C_{oss\text{ eq.}}$  is defined as a constant equivalent capacitance giving the same charging time as  $C_{oss}$  when  $V_{DS}$  increases from 0 to 80%  $V_{DSS}$ .

**Table 6. Switching times**

Symbol	Parameter	Test conditions	Min.	Typ.	Max.	Unit
$t_{d(on)}$	Turn-on delay time	$V_{DD} = 325\text{ V}, I_D = 34\text{ A},$ $R_G = 4.7\text{ }\Omega, V_{GS} = 10\text{ V}$	-	23	-	ns
$t_r$	Rise time		-	12	-	ns
$t_{d(off)}$	Turn-off delay time	(see Figure 13. Switching times test circuit for resistive load and Figure 18. Switching time waveform)	-	69	-	ns
$t_f$	Fall time		-	7.5	-	ns

**Table 7. Source-drain diode**

Symbol	Parameter	Test conditions	Min.	Typ.	Max.	Unit
$I_{SD}$	Source-drain current		-		55	A
$I_{SDM}^{(1)}$	Source-drain current (pulsed)		-		172	A
$V_{SD}^{(2)}$	Forward on voltage	$V_{GS} = 0\text{ V}$ , $I_{SD} = 48\text{ A}$	-		1.6	V
$t_{rr}$	Reverse recovery time	$I_{SD} = 48\text{ A}$ , $di/dt = 100\text{ A}/\mu\text{s}$ ,	-	135		ns
$Q_{rr}$	Reverse recovery charge	$V_{DD} = 60\text{ V}$	-	0.641		$\mu\text{C}$
$I_{RRM}$	Reverse recovery current	(see Figure 15. Test circuit for inductive load switching and diode recovery times)	-	9.5		A
$t_{rr}$	Reverse recovery time	$I_{SD} = 48\text{ A}$ , $di/dt = 100\text{ A}/\mu\text{s}$ ,	-	245		ns
$Q_{rr}$	Reverse recovery charge	$V_{DD} = 60\text{ V}$ , $T_J = 150\text{ }^\circ\text{C}$	-	2.45		$\mu\text{C}$
$I_{RRM}$	Reverse recovery current	(see Figure 15. Test circuit for inductive load switching and diode recovery times)	-	20		A

1. Pulse width is limited by safe operating area.
2. Pulse test: pulse duration = 300  $\mu\text{s}$ , duty cycle 1.5%.

## 2.1 Electrical characteristics (curves)

**Figure 1. Safe operating area**

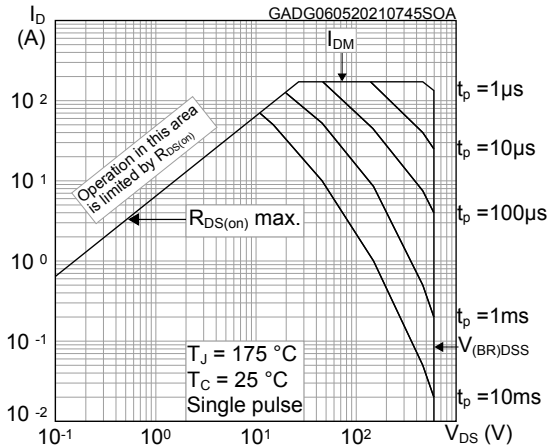

**Figure 2. Maximum transient thermal impedance**

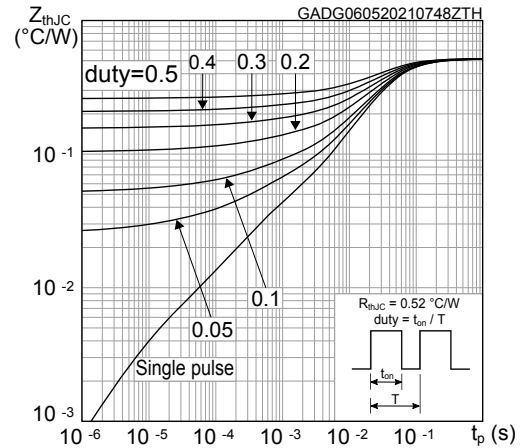

**Figure 3. Typical output characteristics**

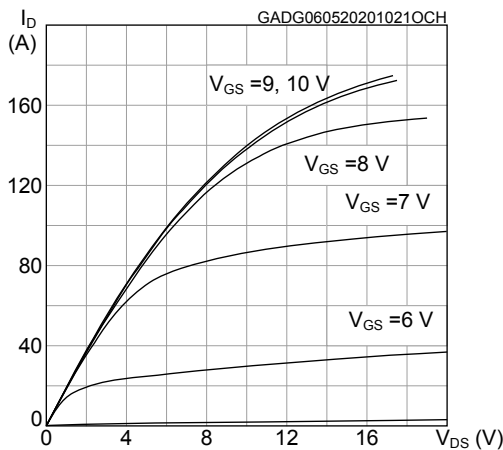

**Figure 4. Typical transfer characteristics**

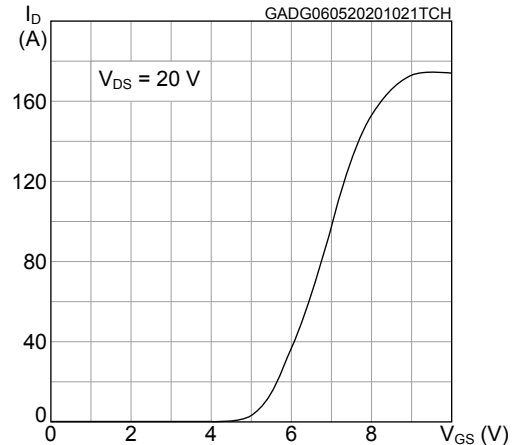

**Figure 5. Typical gate charge characteristics**

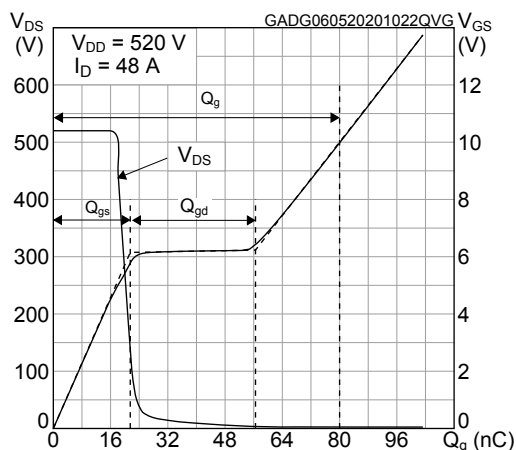

**Figure 6. Typical drain-source on-resistance**

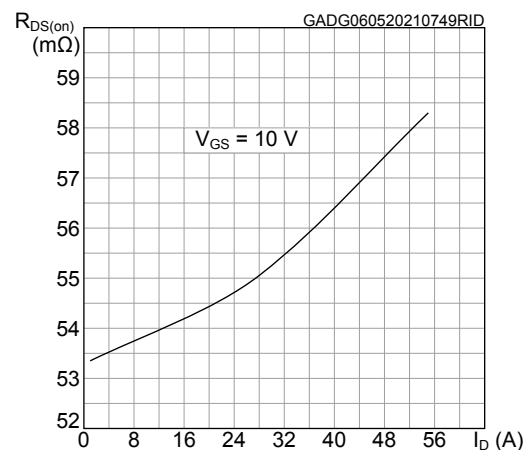

**Figure 7. Typical capacitance characteristics**

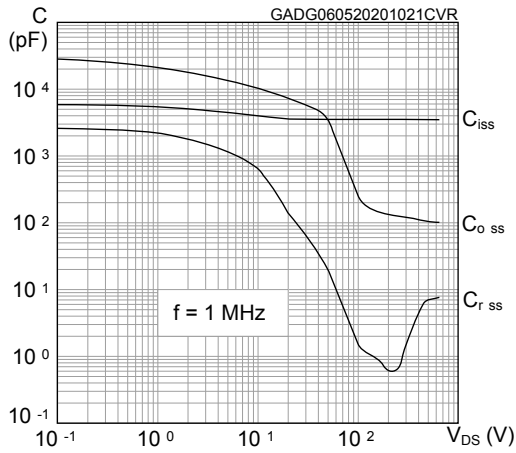

**Figure 8. Normalized gate threshold vs temperature**

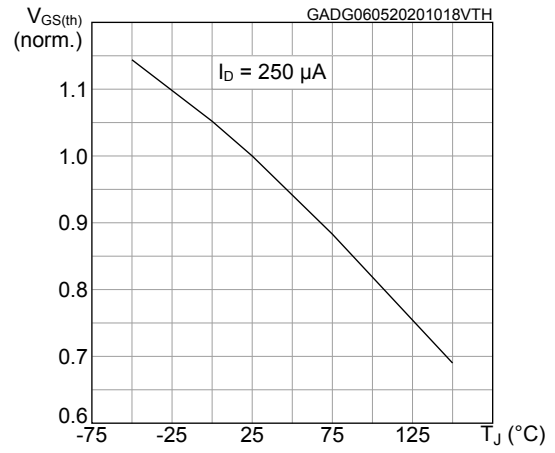

**Figure 9. Normalized on-resistance vs. temperature**

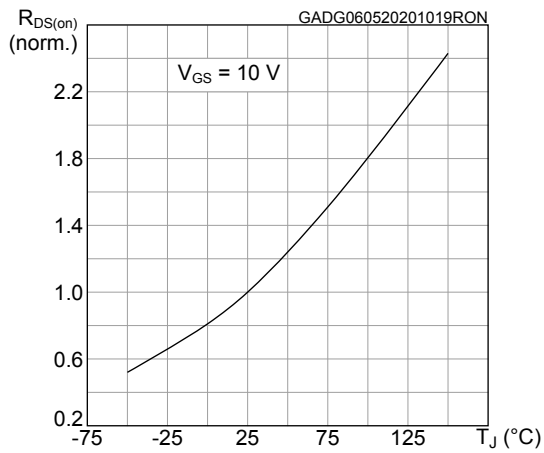

**Figure 10. Normalized breakdown voltage vs temperature**

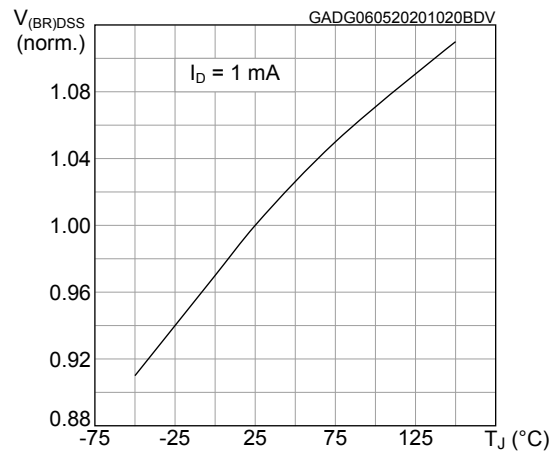

**Figure 11. Typical output capacitance stored energy**

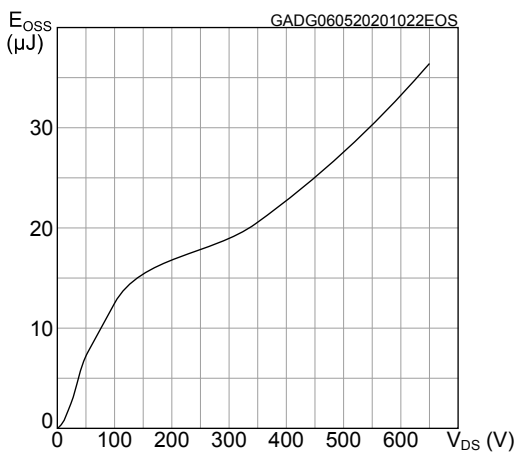

**Figure 12. Typical reverse diode forward characteristics**

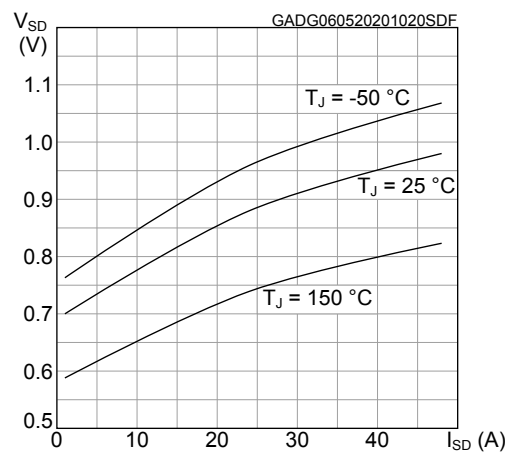

### 3 Test circuits

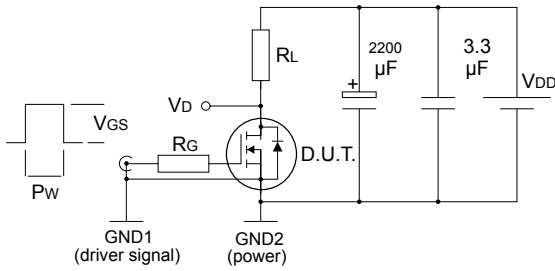
**Figure 13. Switching times test circuit for resistive load**

AM15855v1

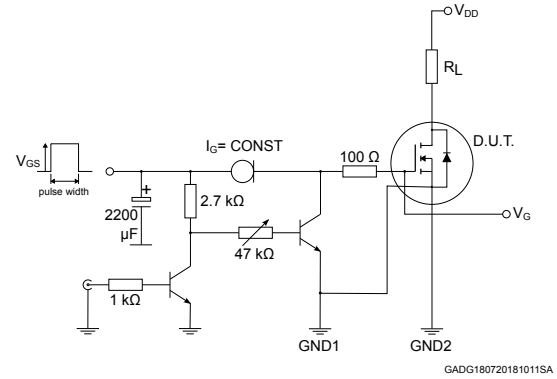
**Figure 14. Test circuit for gate charge behavior**

GADG180720181011SA

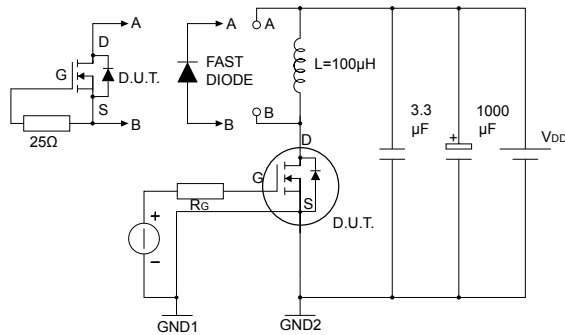
**Figure 15. Test circuit for inductive load switching and diode recovery times**

AM15857v1

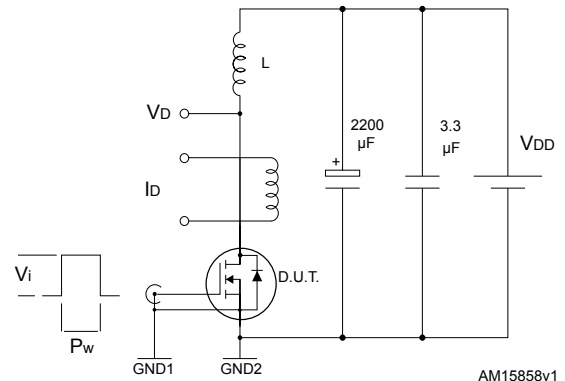
**Figure 16. Unclamped inductive load test circuit**

AM15858v1

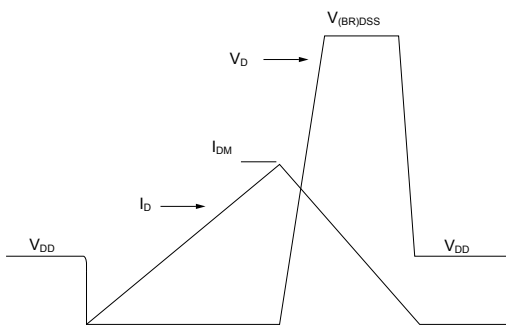
**Figure 17. Unclamped inductive waveform**

AM01472v1

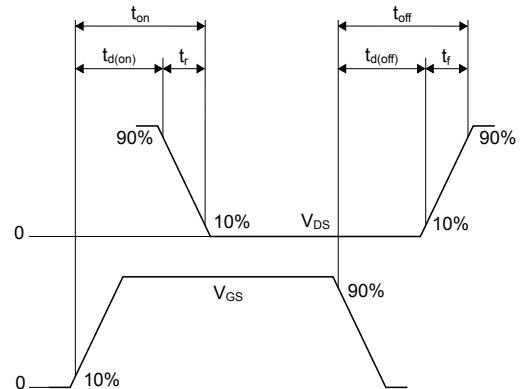
**Figure 18. Switching time waveform**

AM01473v1

## 4 Package information

In order to meet environmental requirements, ST offers these devices in different grades of **ECOPACK** packages, depending on their level of environmental compliance. ECOPACK specifications, grade definitions and product status are available at: [www.st.com](http://www.st.com). ECOPACK is an ST trademark.

### 4.1 TO-LL type A2 package information

**Figure 19. TO-LL type A2 package outline**

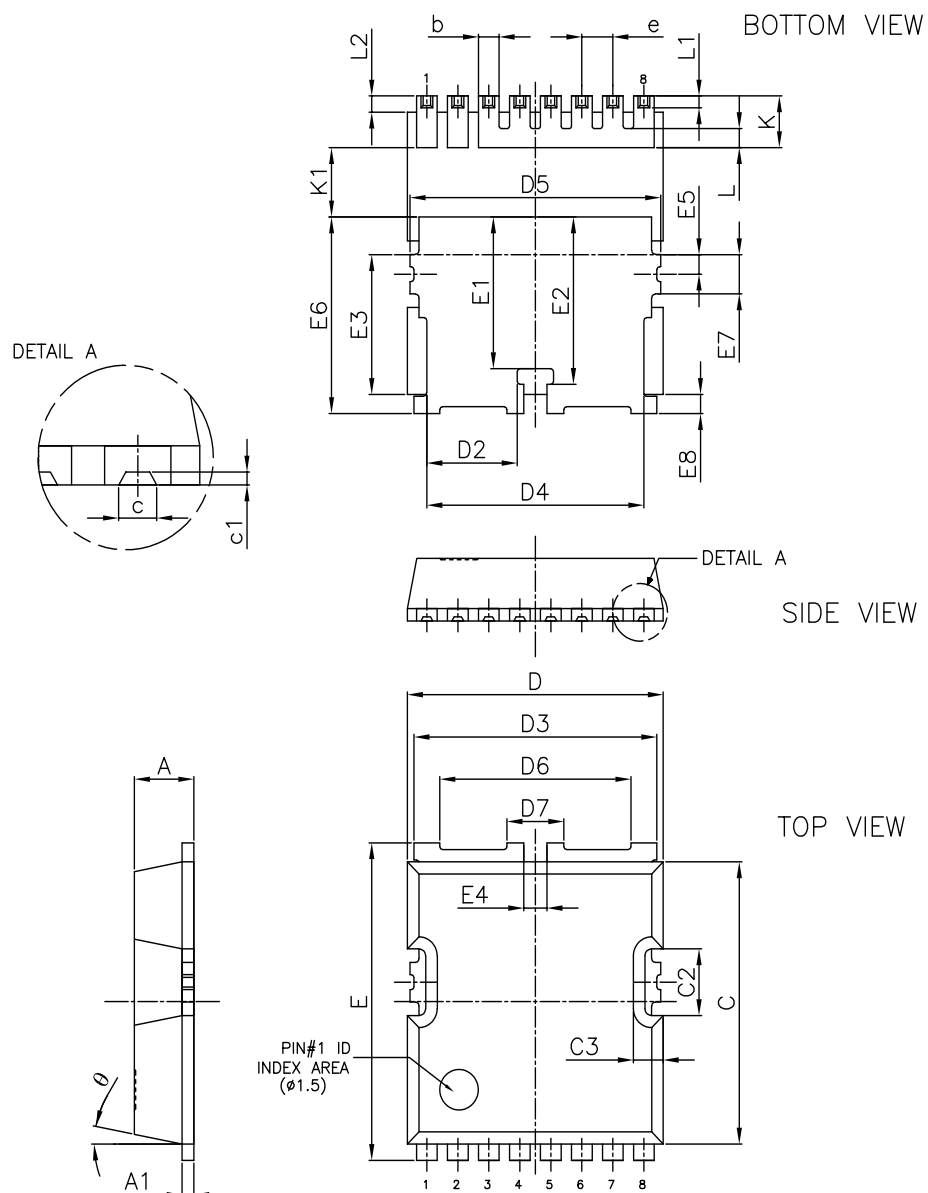

DM00276569\_5\_type\_A2

**Table 8. TO-LL type A2 package mechanical data**

Dim.	mm		
	Min.	Typ.	Max.
A	2.20	2.30	2.40
A1	0.40	0.48	0.60
b	0.70	0.80	0.90
c		0.46	
c1		0.15	
C	10.28	10.38	10.48
C2	2.35	2.45	2.55
C3		1.16	
D	9.80	9.90	10.00
D2	3.30	3.50	3.70
D3	9.30	9.40	9.50
D4	8.20	8.40	8.60
D5	9.50	9.70	9.90
D6		7.40	
D7		2.20	
e		1.20	
E	11.48	11.68	11.88
E1		5.58	
E2		6.15	
E3		5.14	
E4		0.90	
E5		0.72	
E6	7.03	7.23	7.43
E7		1.44	
E8	0.50	0.70	0.90
K	1.70	1.90	2.10
K1	2.40		
L		0.70	
L1		0.44	
L2	0.40	0.60	0.80
θ		11°	

Figure 20. TO-LL type A2 recommended footprint (dimensions are in mm)

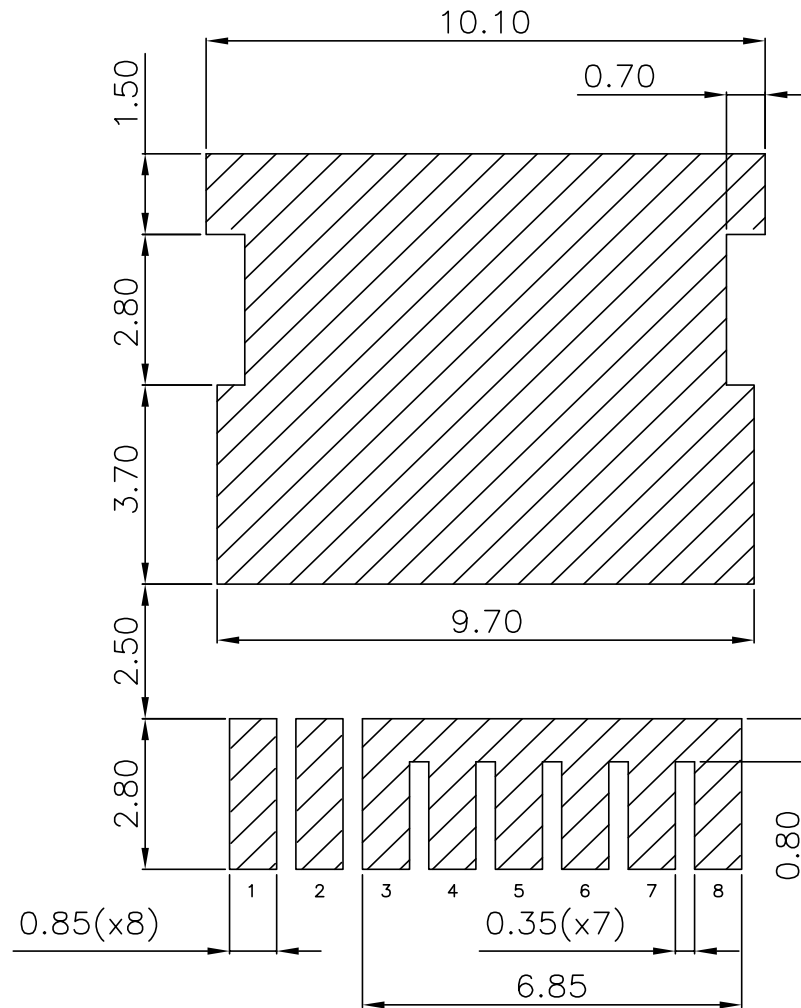

DM00276569\_5\_type\_A2

## 4.2 TO-LL packing information

Figure 21. Carrier tape outline and dimensions

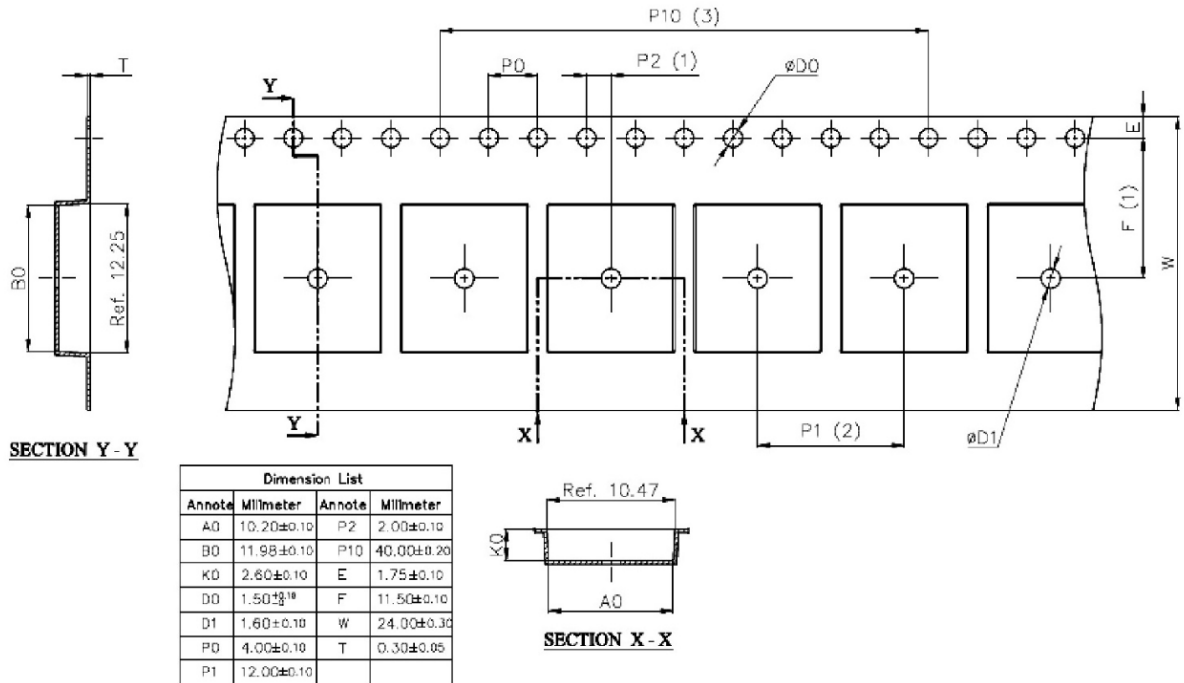
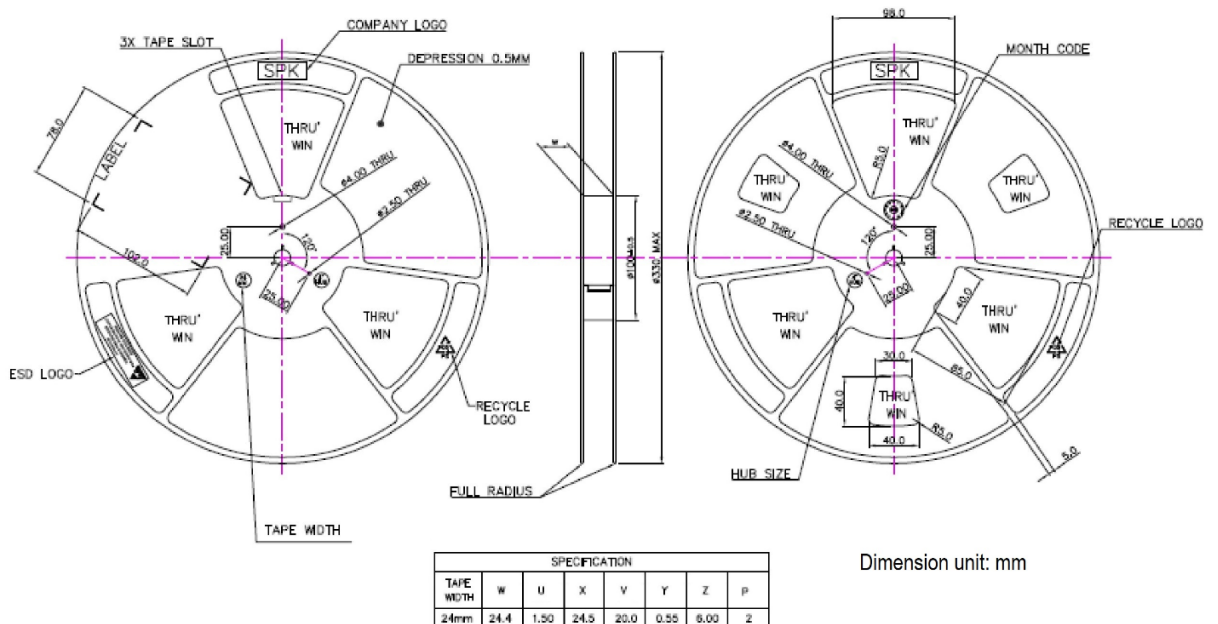
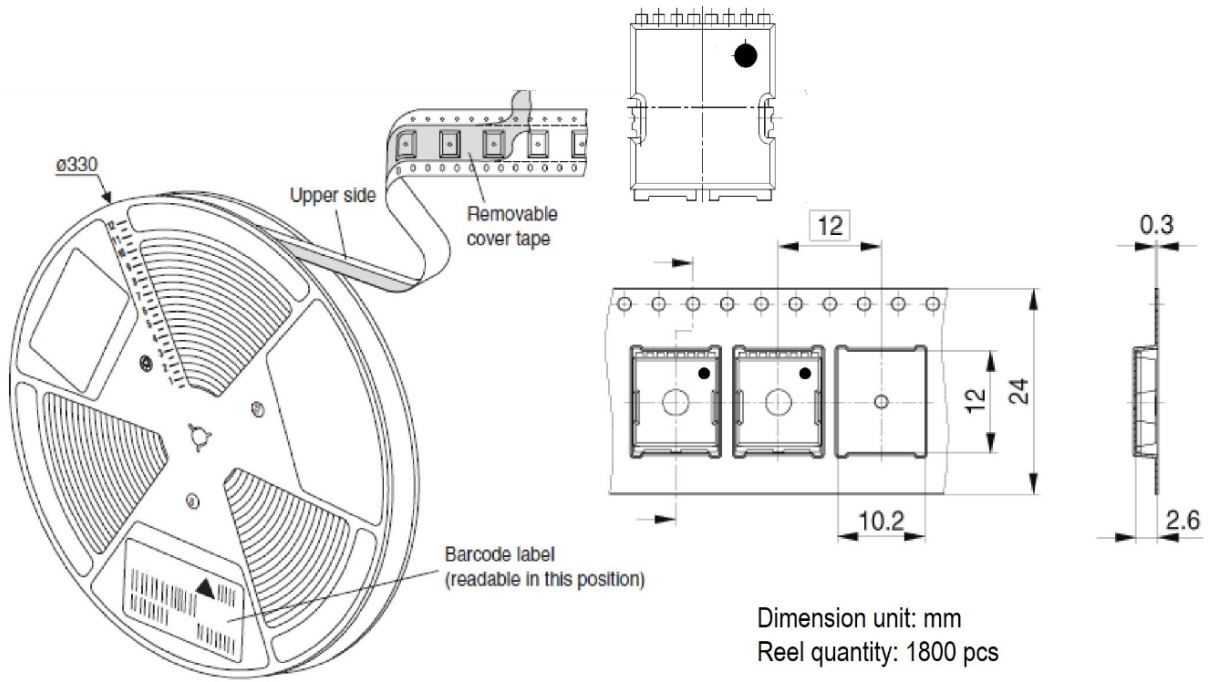

Figure 22. Reel outline and dimensions



**Figure 23. TO-LL orientation in tape pocket**



## Revision history

Table 9. Document revision history

Date	Version	Changes
06-May-2021	1	First release.

---

## Contents

<b>1</b>	<b>Electrical ratings</b> .....	<b>2</b>
<b>2</b>	<b>Electrical characteristics</b> .....	<b>3</b>
<b>2.1</b>	Electrical characteristics (curves) .....	<b>5</b>
<b>3</b>	<b>Test circuits</b> .....	<b>7</b>
<b>4</b>	<b>Package information</b> .....	<b>8</b>
<b>4.1</b>	TO-LL type A2 package information .....	<b>8</b>
<b>4.2</b>	TO-LL packing information .....	<b>11</b>
	<b>Revision history</b> .....	<b>13</b>

**IMPORTANT NOTICE – PLEASE READ CAREFULLY**

STMicroelectronics NV and its subsidiaries (“ST”) reserve the right to make changes, corrections, enhancements, modifications, and improvements to ST products and/or to this document at any time without notice. Purchasers should obtain the latest relevant information on ST products before placing orders. ST products are sold pursuant to ST’s terms and conditions of sale in place at the time of order acknowledgement.

Purchasers are solely responsible for the choice, selection, and use of ST products and ST assumes no liability for application assistance or the design of Purchasers’ products.

No license, express or implied, to any intellectual property right is granted by ST herein.

Resale of ST products with provisions different from the information set forth herein shall void any warranty granted by ST for such product.

ST and the ST logo are trademarks of ST. For additional information about ST trademarks, please refer to [www.st.com/trademarks](http://www.st.com/trademarks). All other product or service names are the property of their respective owners.

Information in this document supersedes and replaces information previously supplied in any prior versions of this document.

© 2021 STMicroelectronics – All rights reserved