

RF Inductor



BWCM Series



Overview

Wire-wound RF inductors are electronic components designed to store energy in a magnetic field when electrical current passes through them. They are constructed by winding a conductive wire (usually copper or gold-plated) around a core material such as air, ceramic, or ferrite.

This configuration allows them to provide high inductance values with minimal power loss, especially at high frequencies.

Benefits

1. High Q-Factor (Quality Factor)
2. Ceramic body and wire wound construction provide high SRFs
3. Low DC resistance design
4. High Current Handling
5. Can maintain excellent thermal stability at different temperatures

Applications

1. Industrial and Medical Equipmen: RFID systems and medical imaging equipment.
2. Data Centers
3. Networking
4. Base Station
5. Consumer Electronics
6. Security system

Product Information

Series	Size Code (JIS/EIA)	Inductance (nH)
BWCM	0603/0201 1005/0402 1608/0603	1 ~ 470



BWCM00161008 Series Specification

1 Scope: This specification applies to Wire Wound Ceramic Chip Inductors

2 Part Numbering:

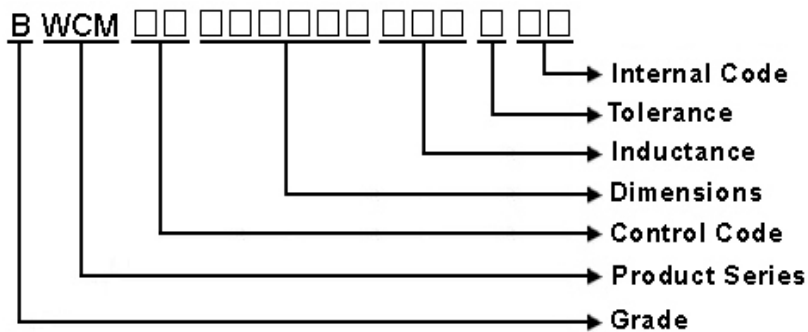

3 Rating:

Operating Temperature: - 40°C ~ 125°C
(Including self - temperature rise)

Storage Temperature: - 40°C ~ 125°C
(The storage temperature range is for after the assembly)

4 Marking:

No Marking

5 Standard Testing Condition

	Unless otherwise specified	In case of doubt
Temperature	Ordinary Temperature(15 to 35°C)	20 to 30°C
Humidity	Ordinary Humidity(25 to 85% RH)	50 to 80 %RH

BWCM00161008 Series Specification

6 Configuration and Dimensions and Unit Weight:

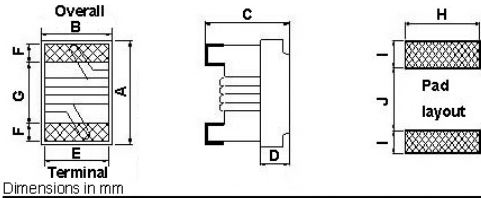

Dimensions in mm

TYPE	A	B	C	D	E	F	G	H	I	J
161008	1.6 ^{+0.2} _{-0.1}	1.02±0.1	0.82 ^{+0.2} _{-0.1}	0.35	0.70	0.30	0.95	1.02	0.64	0.64

Net Weight (grms)

SIZE CODE	Net Weight (grms)
161008	0.00335 (typ.)

7 Electrical Characteristics:

Part No.	Inductance (nH)	L/Q Test		Q Min.	SRF (MHz)Min.	RDC (Ω)Max.	I _{rms} (mA)Max.	Tolerance
		Inductance	Freq.					
BWCM001610082N2□00	2.2	100/250	16	6000	0.049	700	B,C,D	
BWCM001610083N6□00	3.6	100/250	25	6000	0.059	850	H,J,G	
BWCM001610083N9□00	3.9	100/250	35	6000	0.059	850	H,J	
BWCM001610084N3□00	4.3	100/250	35	6000	0.059	850	H,J	
BWCM001610084N7□00	4.7	100/250	35	6000	0.059	850	H,J,D	
BWCM001610085N6□00	5.6	100/250	35	6000	0.082	750	H,J,C	
BWCM001610086N2□00	6.2	100/250	35	6000	0.082	750	H,J	
BWCM001610086N8□00	6.8	100/250	35	6000	0.082	750	H,J	
BWCM001610087N5□00	7.5	100/250	35	6000	0.082	750	H,J	
BWCM001610088N2□00	8.2	100/250	35	6000	0.11	650	H,J	
BWCM001610088N7□00	8.7	100/250	35	6000	0.11	650	H,J	
BWCM001610089N1□00	9.1	100/250	35	6000	0.11	650	C,H,J	
BWCM001610089N5□00	9.5	100/250	35	6000	0.11	650	G,H,J	
BWCM0016100810N□00	10	100/250	35	6000	0.11	650	G,J	
BWCM0016100811N□00	11	100/250	35	6000	0.11	650	G,J	
BWCM0016100812N□00	12	100/250	35	6000	0.13	600	G,J	
BWCM0016100813N□00	13	100/250	35	6000	0.13	600	G,J	
BWCM0016100815N□00	15	100/250	40	6000	0.13	600	G,J	
BWCM0016100816N□00	16	100/250	40	5500	0.16	550	G,J	
BWCM0016100818N□00	18	100/250	40	5500	0.16	550	G,J	
BWCM0016100820N□00	20	100/250	40	4900	0.16	550	G,J	
BWCM0016100822N□00	22	100/250	40	4600	0.17	500	G,J	
BWCM0016100824N□00	24	100/250	40	3800	0.21	500	G,J	
BWCM0016100827N□00	27	100/250	40	3700	0.21	440	G,J	
BWCM0016100830N□00	30	100/250	40	3300	0.23	420	G,J	

NOTE: □-tolerance B=±0.1nH / C=±0.2nH / D=±0.5nH / H=±3% / J=±5% / G=±2%

1. Operating temperature range - 4 0 °C ~ 1 2 5 °C (Including self - temperature rise)
2. I_{rms} for a 15 °C temperature rise from 25 °C ambient.
3. L/Q Test OSC @200mV.
4. Inductance would be correct Chilisin standard piece.
5. offset value -0.771n H

BWCM00161008 Series Specification

Part No.	Inductance (nH)	L/Q Test		SRF (MHz)Min.	RDC (Ω)Max.	I _{rms} (mA)Max.	Tolerance
		Freq. (MHz)	Q Min.				
BWCM0016100833N□00	33	100/250	40	3200	0.23	420	G,J
BWCM0016100836N□00	36	100/250	40	2900	0.26	400	G,J
BWCM0016100839N□00	39	100/250	40	2800	0.26	400	G,J
BWCM0016100843N□00	43	100/200	40	2700	0.29	380	G,J
BWCM0016100847N□00	47	100/200	38	2600	0.29	380	G,J
BWCM0016100851N□00	51	100/200	38	2500	0.33	370	G,J
BWCM0016100856N□00	56	100/200	38	2400	0.35	360	G,J
BWCM0016100862N□00	62	100/200	38	2300	0.51	280	G,J
BWCM0016100868N□00	68	100/200	38	2200	0.38	340	G,J
BWCM0016100872N□00	72	100/150	34	2100	0.56	270	G,J
BWCM0016100875N□00	75	100/150	34	2050	0.56	270	G,J
BWCM0016100882N□00	82	100/150	34	2000	0.6	250	G,J
BWCM0016100891N□00	91	100/150	34	1900	0.64	230	G,J
BWCM00161008R10□00	100	100/150	34	1800	0.68	220	G,J
BWCM00161008R11□00	110	100/150	32	1700	1.2	200	G,J
BWCM00161008R12□00	120	100/150	32	1600	1.3	180	G,J
BWCM00161008R13□00	130	100/150	32	1450	1.4	170	G,J
BWCM00161008R15□00	150	100/150	32	1400	1.5	160	G,J
BWCM00161008R16□00	160	100/150	32	1350	2.1	150	G,J
BWCM00161008R18□00	180	100/100	25	1300	2.2	140	G,J
BWCM00161008R20□00	200	100/100	25	1250	2.4	120	G,J
BWCM00161008R22□00	220	100/100	25	1200	2.5	120	G,J
BWCM00161008R27□00	270	100/100	30	960	3.4	110	G,J
BWCM00161008R33□00	330	100/100	30	800	5.5	85	G,J
BWCM00161008R39□00	390	100/100	30	800	6.2	80	G,J
BWCM00161008R47□00	470	100/100	30	700	7	75	G,J

NOTE: □-tolerance B=±0.1nH / C=±0.2nH / D=±0.5nH / H=±3% / J=±5% / G=±2%

1. Operating temperature range - 4 0 °C ~ 1 2 5 °C(Including self - temperature rise)
2. I_{rms} for a 15°C temperature rise from 25°C ambient.
3. L/Q Test OSC @200mV.
4. Inductance would be correct Chilisin standard piece.
5. offset value -0.771n H

BWCM00161008 Series Specification

8 BWCM00161008 Series

8.1 Construction:

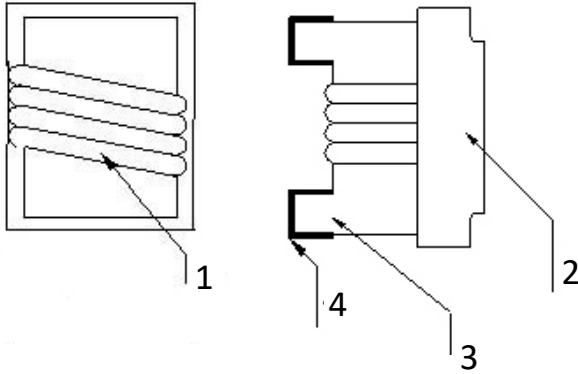

8.2 Material List:

NO	PART	MATERIAL
1	WIRE	COPPER 180
2	EPOXY	UV GLUE
3	CORE	CERAMIC
4	TERMINAL	Ag/Ni/Sn

BWCM00161008 Series Specification

9 Reliability Of Ceramic Wire Wound Chip Inductor/CERAMIC SERIES

1-1.Environmental Performance

No	Item	Specification	Test Method		
1-1-1	Temperature Cycle	Appearance: No Damage Inductance: within $\pm 10\%$ of initial value Q change: within $\pm 30\%$ of initial value	One cycle:		
			Step	Temperature ($^{\circ}\text{C}$)	Time (min)
			1	-40 \pm 3	30
			2	25 \pm 2	15
			3	125 \pm 3	30
4	25 \pm 2	15			
1-1-2	High Temperature Resistance	There should be no evidence of short or open circle	Total: 5 cycles Measured After Exposure in The Room Condition For 1hrs Temperature: 125 \pm 3 $^{\circ}\text{C}$ Time: 1000Hrs Measured After Exposure In The Room Condition For 1Hrs		
1-1-3	Low Temperature Resistance		Temperature: -40 \pm 3 $^{\circ}\text{C}$ Time: 1000Hrs Measured After Exposure In The Room Condition For 1Hrs		
1-1-4	Humidity Load Life		Temperature: 40 \pm 2 $^{\circ}\text{C}$ Relative Humidity: 90~95% Load: Allowed DC Current Time: 96Hrs		

1-2.Mechanical Performance

No	Item	Specification	Test Method
1-2-1	Vibration Test (Low Frequency)	1. Appearance: No Damage 2. Inductance: within $\pm 10\%$ of initial value 3. Q change: within $\pm 30\%$ of initial value	1. Test device shall be soldered on the substrate. 2. Oscillation frequency: 10 to 55 to 10Hz for 1min. 3. Amplitude: 1.5mm 4. Time: 2hrs for each axis(X, Y & Z), total 6hrs
1-2-2	Resistance TO Soldering Heat	Appearance: No Damage	1. The device should be reflow soldered on PCB (peak 260 $^{\circ}\text{C}$ \pm 5 $^{\circ}\text{C}$ for 10 seconds) 2. Solder Composition: Sn/Ag3.0/Cu0.5 3. Test time: 6 minutes
1-2-3	Solder ability	The electrodes shall be at least 95% covered with new solder coating	1. Pre-Heating: 150 $^{\circ}\text{C}$, 1min. 2. Solder Composition: Sn/Ag3.0/Cu0.5 3. Solder Temperature: 245 \pm 5 $^{\circ}\text{C}$. 4. Immersion Time: 4 \pm 1 sec.
1-2-4	Component Adhesion (Push Test)	1 Lbs. For 0402 2 Lbs. For 0603 4 Lbs. For The Rest	The device should be reflow soldered (245 \pm 5 $^{\circ}\text{C}$ For 10 seconds) to a tinned copper substrate. A force gauge should be applied to the side of the component. The device must withstand a minimum force of 2 or 4 pounds without a failure of the termination attached to component

BWCM00161008 Series Specification

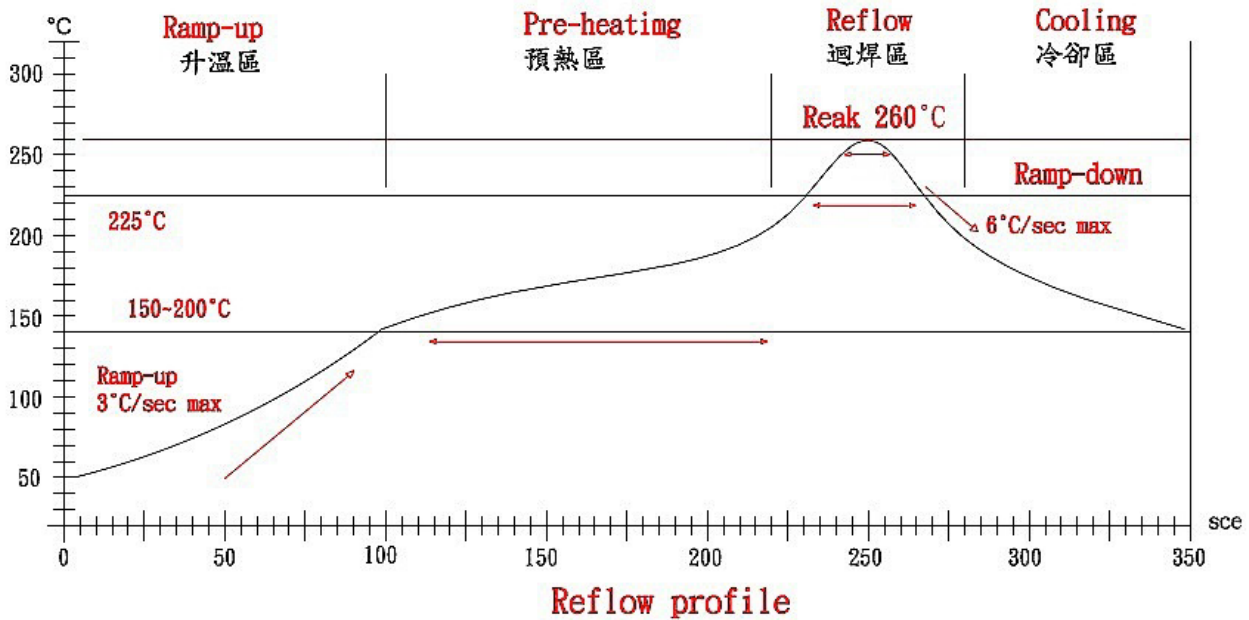

Lead-Free(LF)標準溫度分析範圍

Refer to J-STD-020C

管制項目 Item.	升温區 Ramp-up	預熱區 Pre-heating	迴焊區 Reflow	Peak Temp	冷卻區 Cooling
溫度範圍 Temp.scope	R.T ~ 150°C	150°C ~ 200°C	Above 217°C	260±5°C	Peak Temp.~150°C
標準時間 Time spec.	-	60 ~ 180 sec	60 ~ 150 sec	20 ~ 40 sec	-
實際時間 Time result	-	75 ~ 100 sec	90 ~ 120 sec	20 ~ 35 sec	-

NOTE:

- 1.Re-flow possible times : within 3 times
- 2.Nitrogen adopted is recommends while in re-flow
- 3.Products can only be soldered with reflow

BWCM00161008 Series Specification

10 Packaging:

10.1 Packaging -Cover Tape

The force for tearing off cover tape is 10 to 100 grams in the arrow direction.

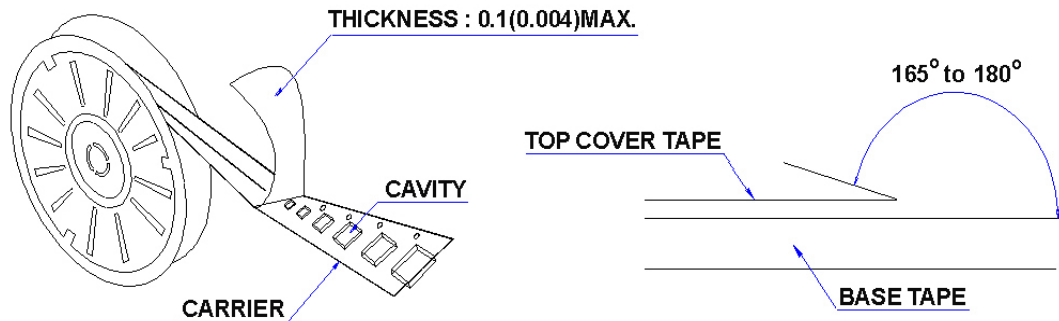

10.2 Packaging Quantity

TYPE	PCS/REEL
161008	4000

10.3 Reel Dimensions

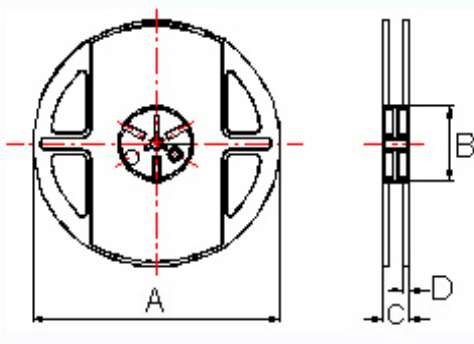

Dimensions in mm

TYPE	A	B	C	D
161008	178±1	60±0.5	12±0.5	1.5±0.5

BWCM00161008 Series Specification

10 Packaging:

10.4 Tape Dimensions in mm

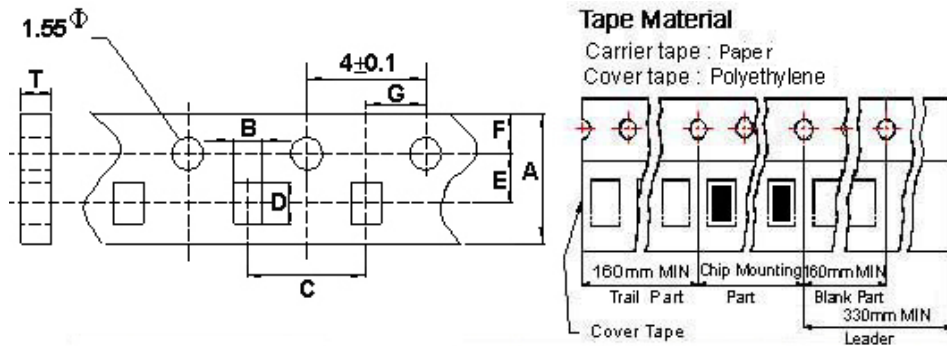

TYPE	A	B	C	D	E	F	G	T
161008	8.0	1.20	4	1.80	3.5	1.75	2	0.75

11 Recommended Land Pattern:

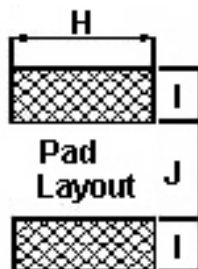

Dimensions in mm

TYPE	H(In/mm)	I(In/mm)	J(In/mm)
161008	0.04/1.02	0.025/0.64	0.025/0.64

12 Note:

- Please make sure that your product has been evaluated and confirmed against your specifications when our product is mounted to your product.
- Do not knock nor drop.
- All the items and parameters in this product specification have been prescribed on the premise that our product is used for the purpose, under the condition and in the environment agreed upon between you and us. You are requested not to use our product deviating from such agreement.
- The storage period is less than 12 months. Be sure to follow the storage conditions (Temperature: 5 to 40°C, Humidity: 10 to 75% RH or less).
If the storage period elapses, the soldering of the terminal electrodes may deteriorate.
- Do not use or store in locations where there are conditions such as gas corrosion (salt, acid, alkali, etc.).
- The moisture sensitivity level (MSL) of products is classified as level 1.

BWCM00161008 Series Specification

13 Graph:

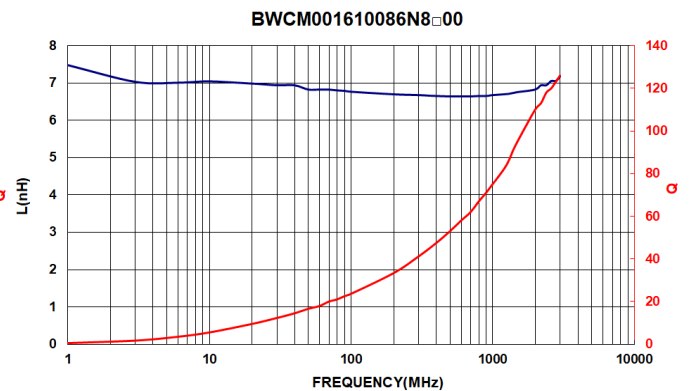
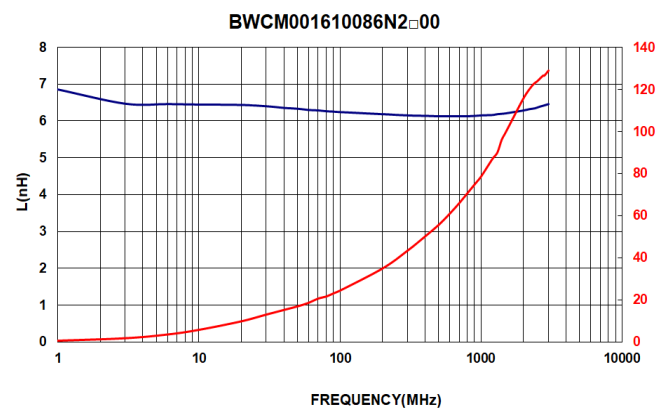
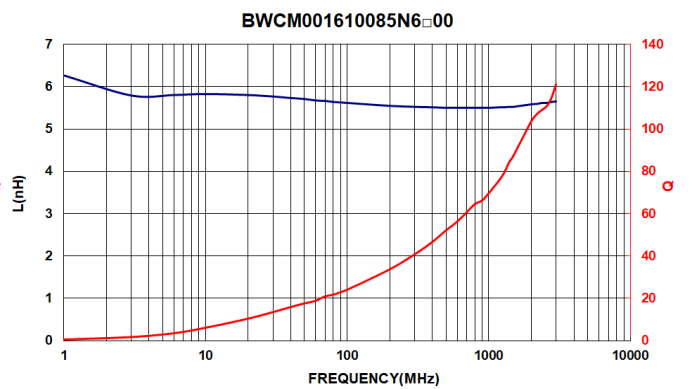
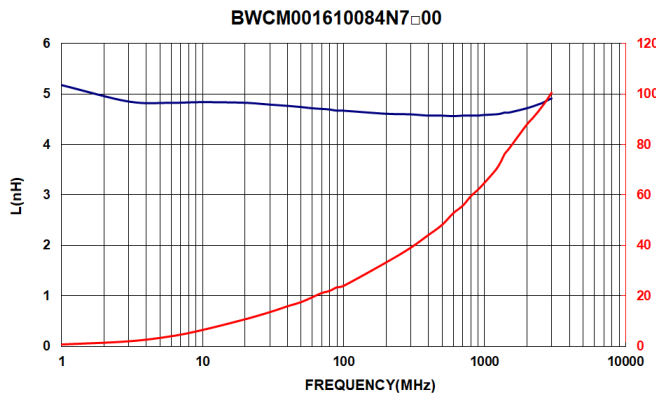
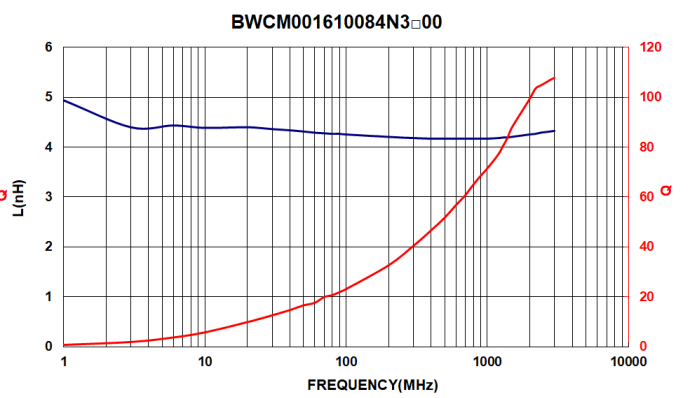
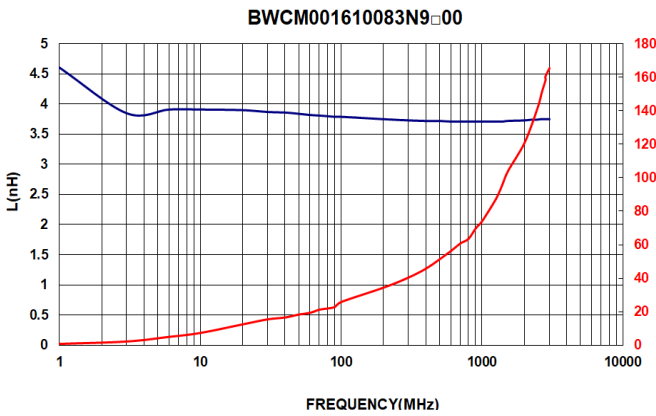
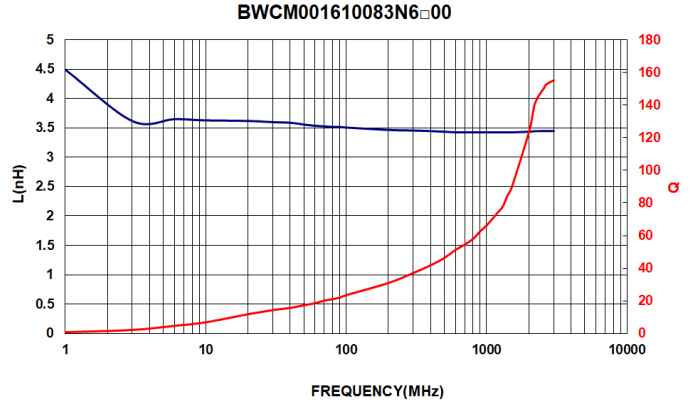
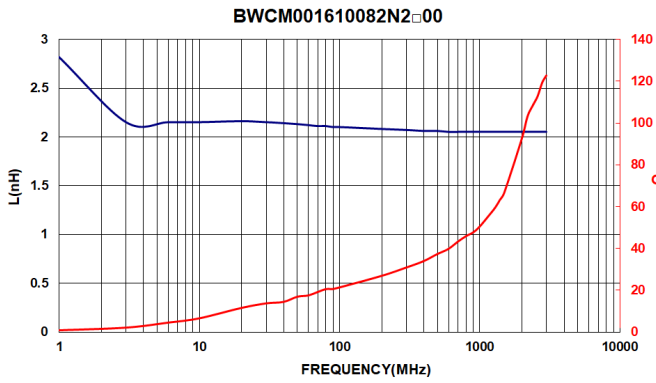

BWCM00161008 Series Specification

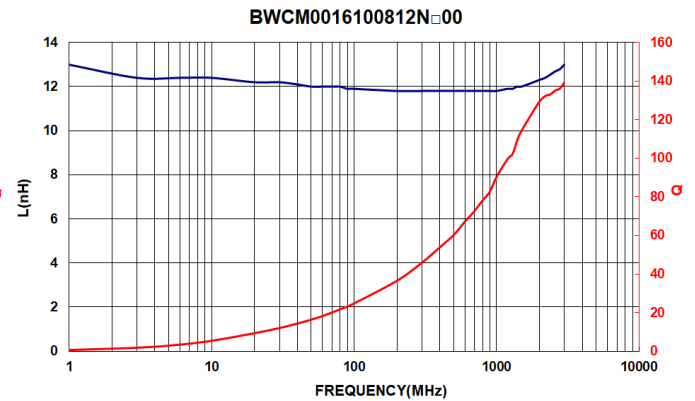
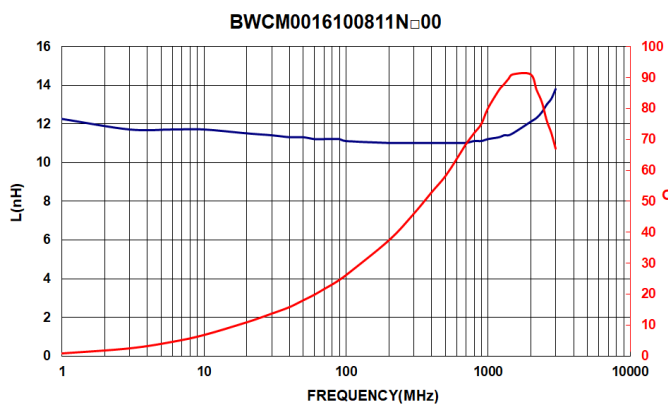
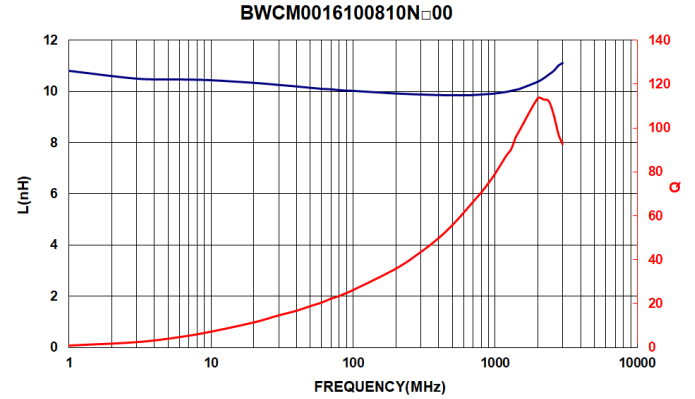
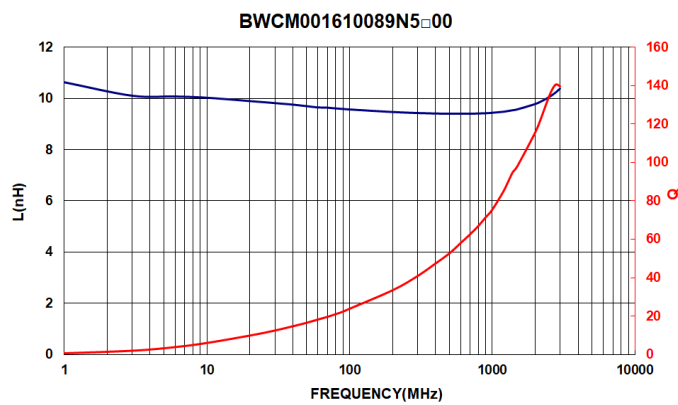
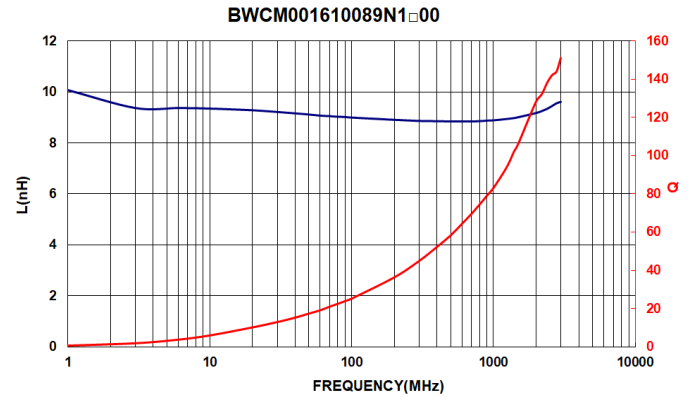
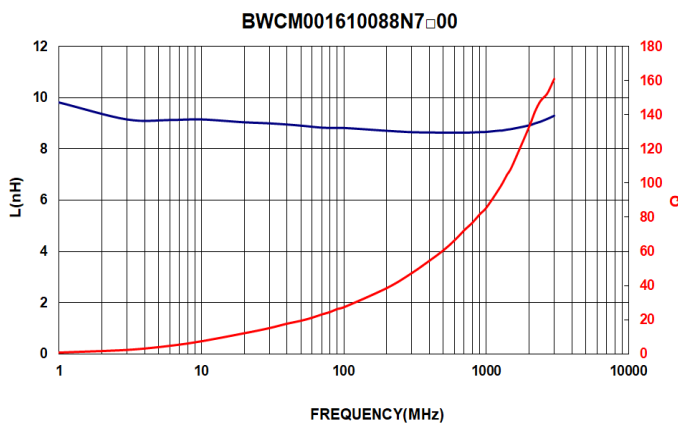
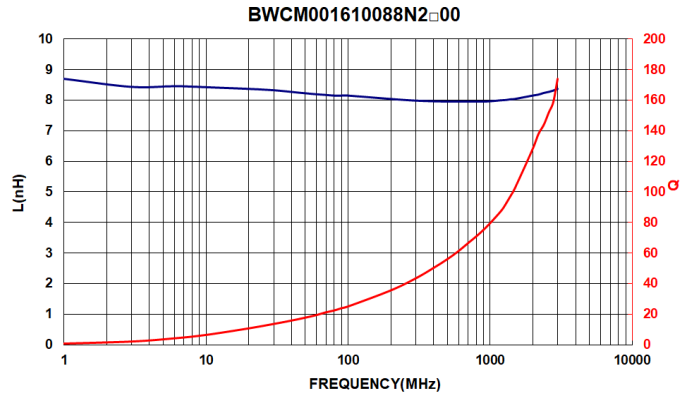
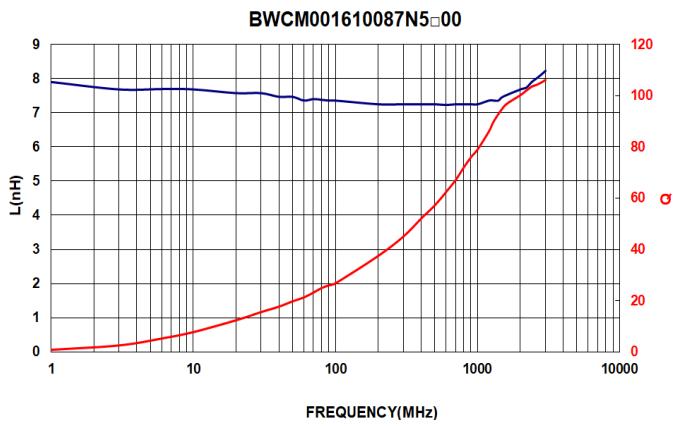

BWCM00161008 Series Specification

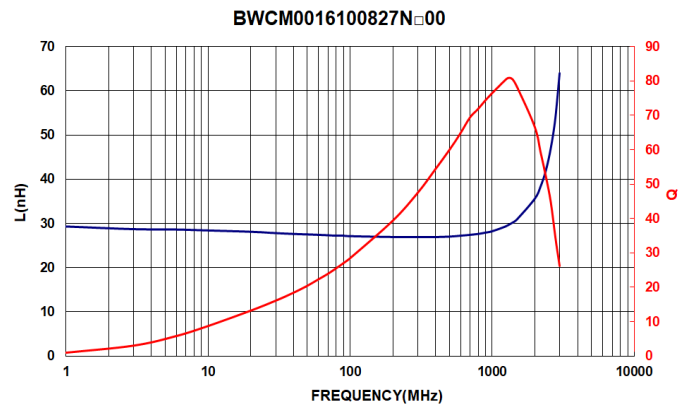
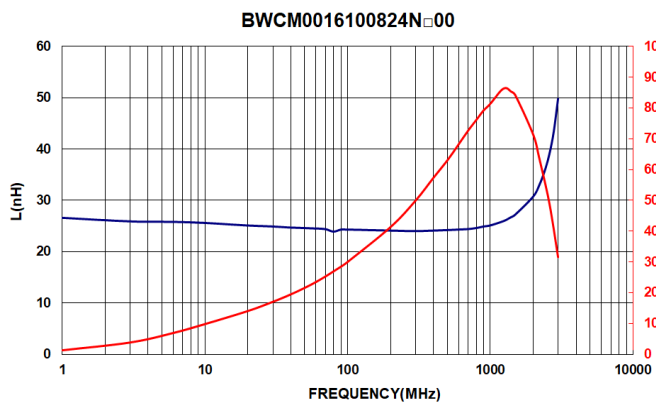
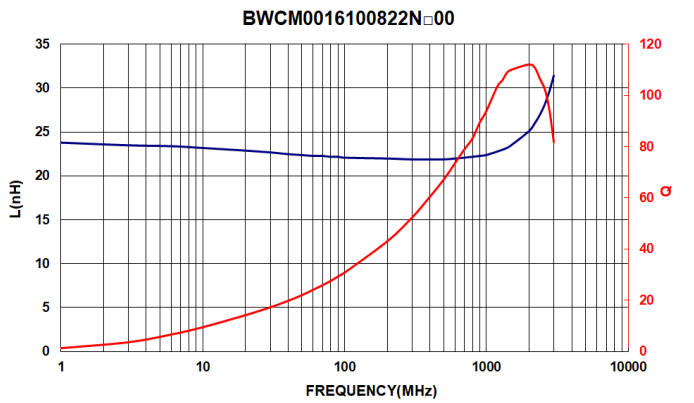
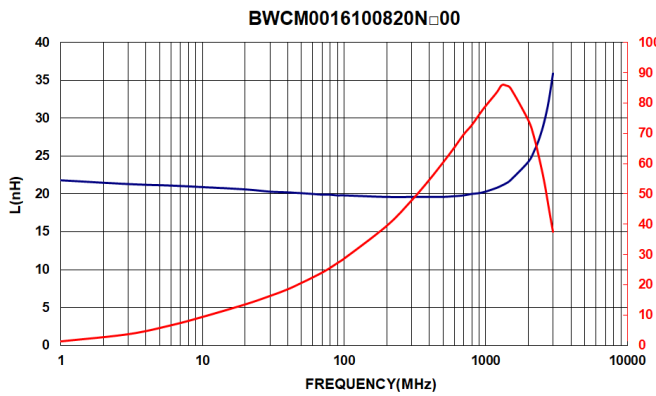
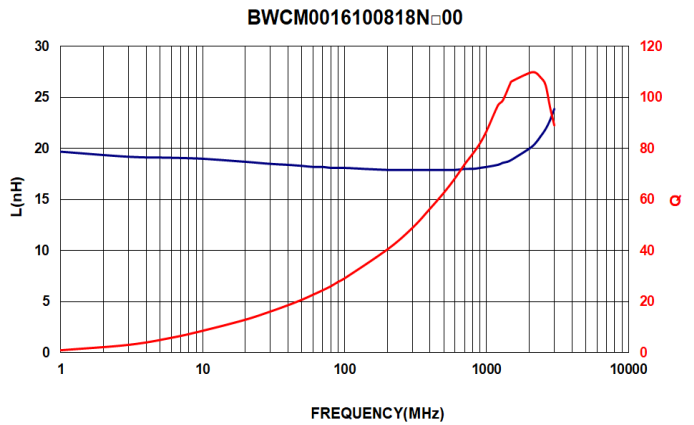
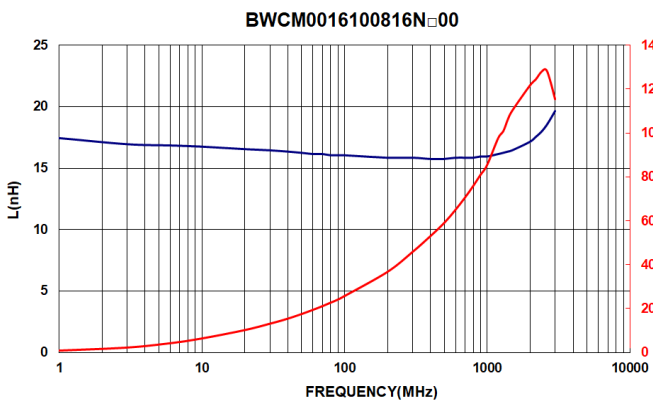
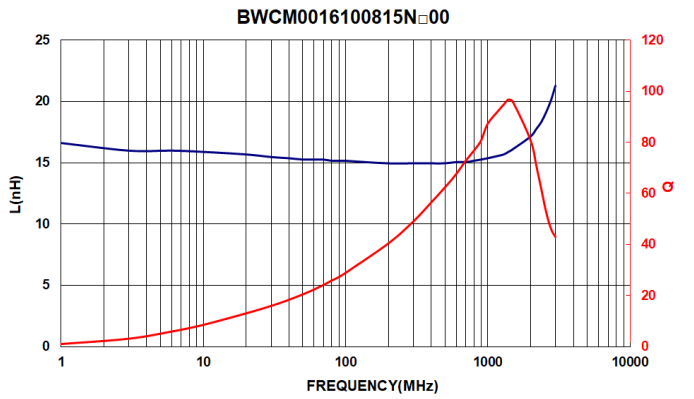
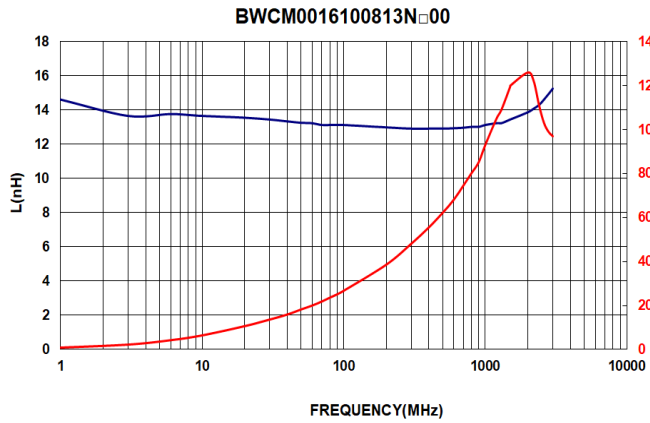

BWCM00161008 Series Specification

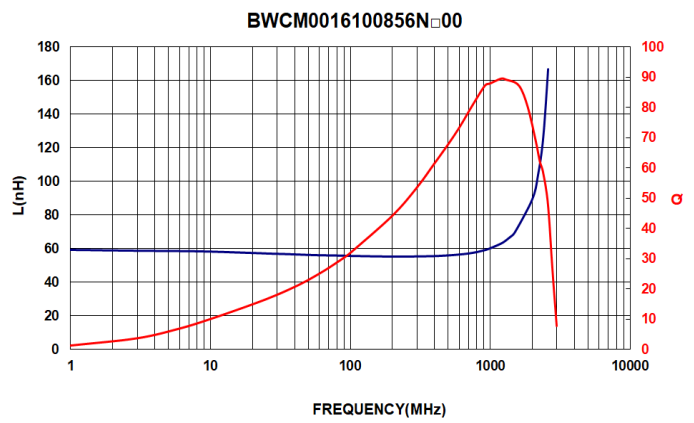
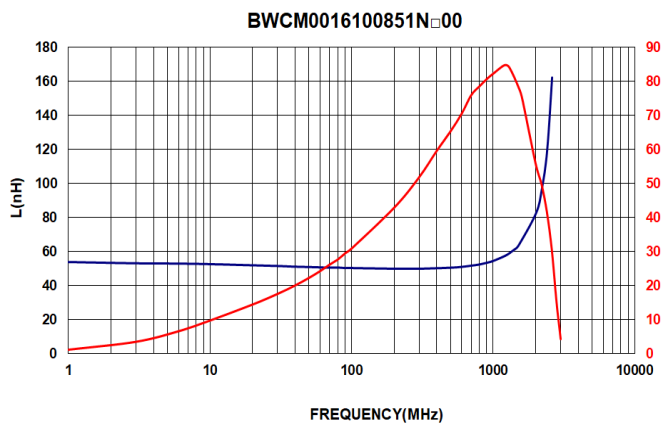
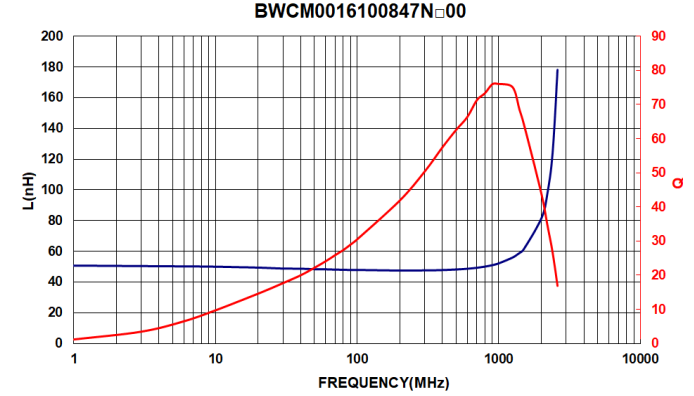
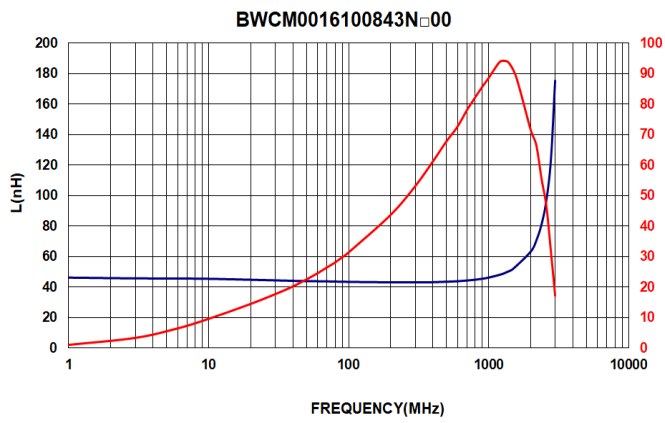
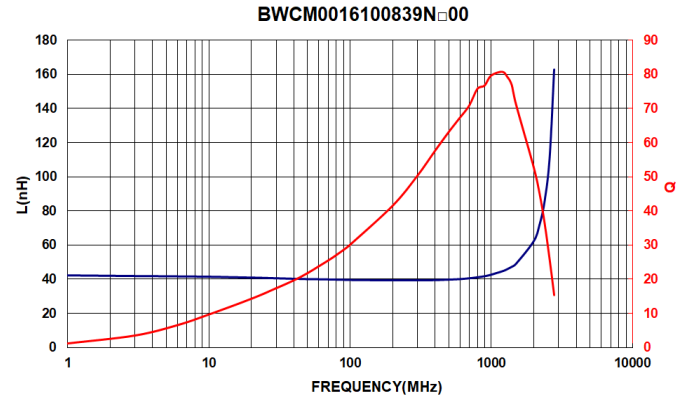
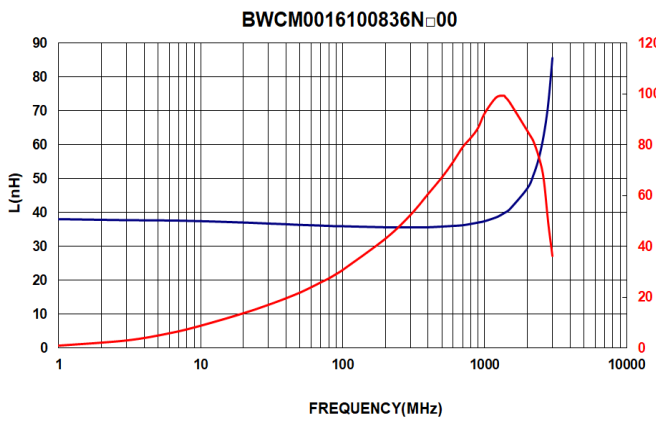
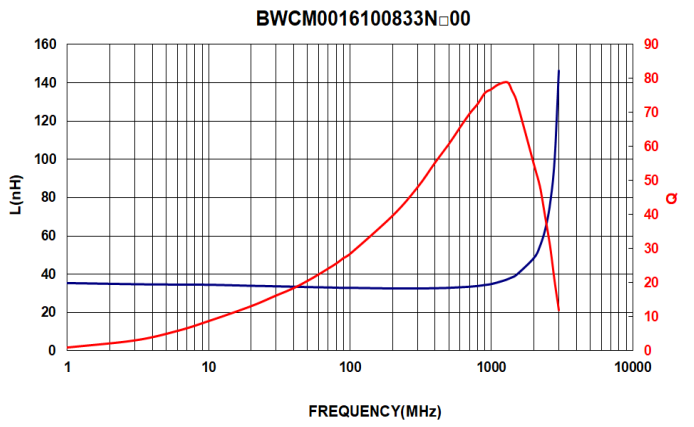
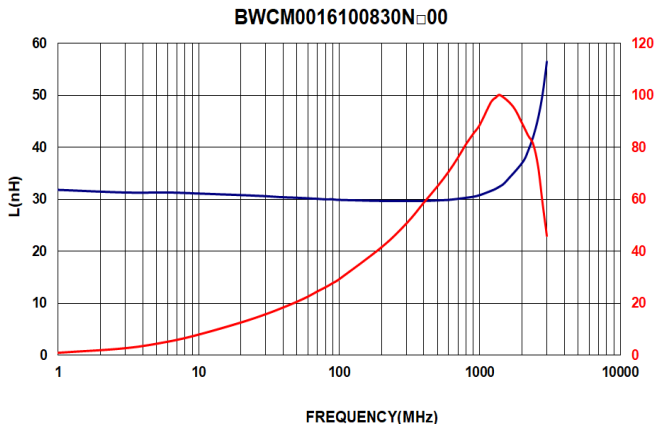

BWCM00161008 Series Specification

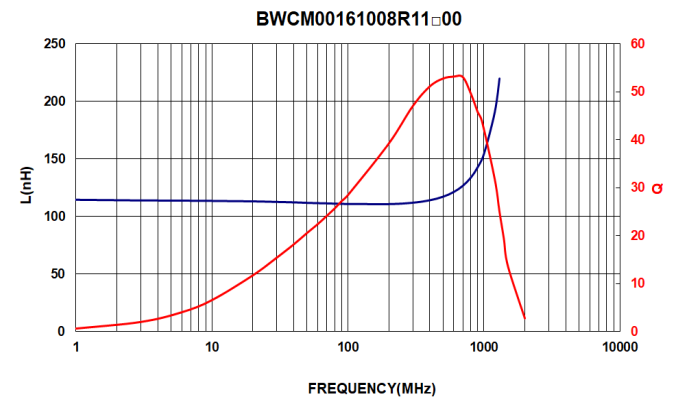
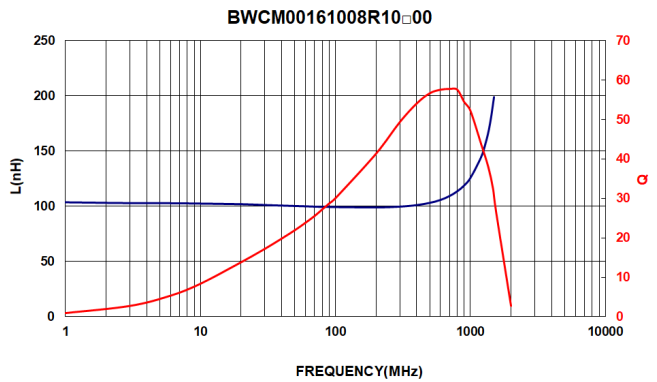
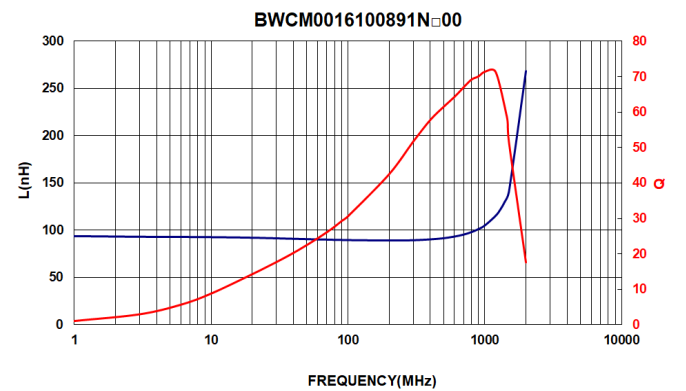
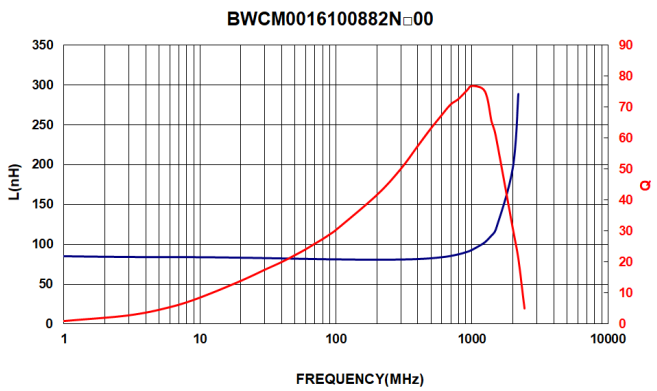
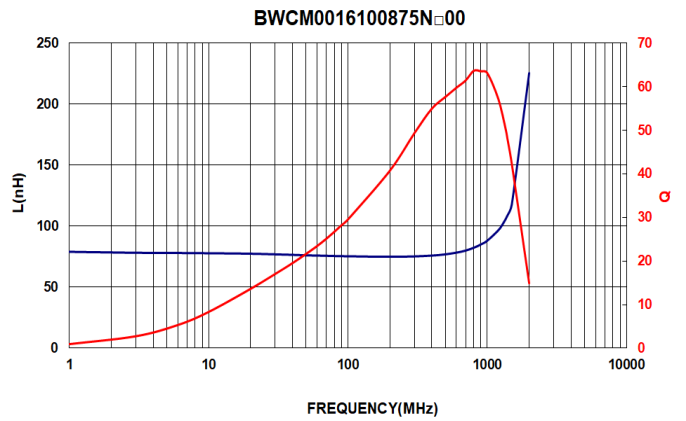
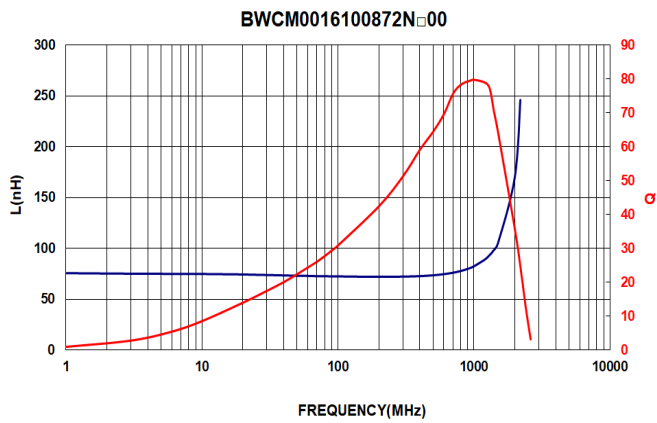
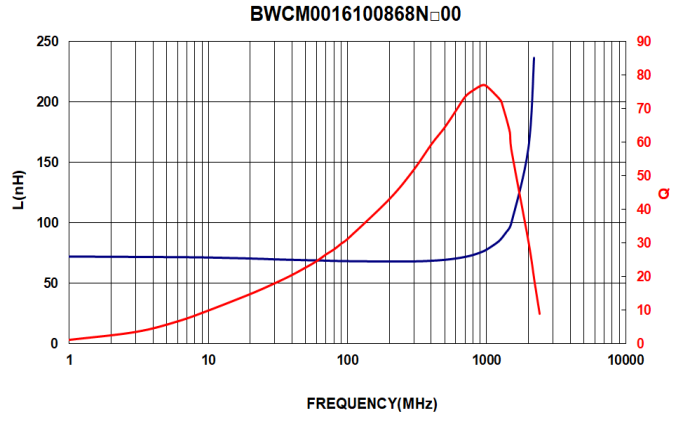
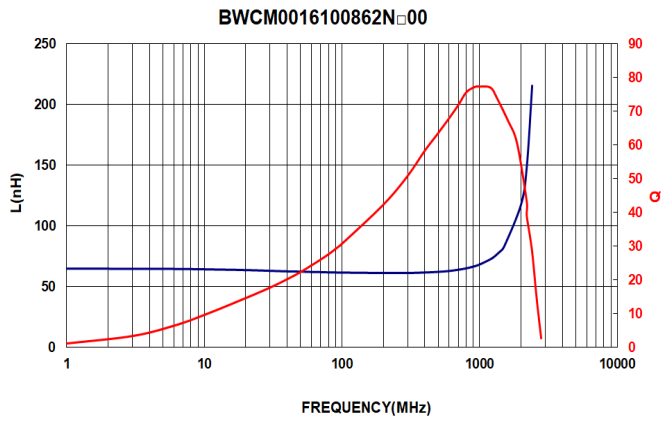

BWCM00161008 Series Specification

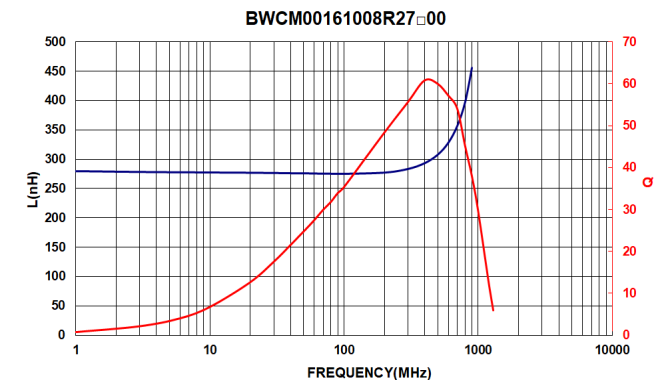
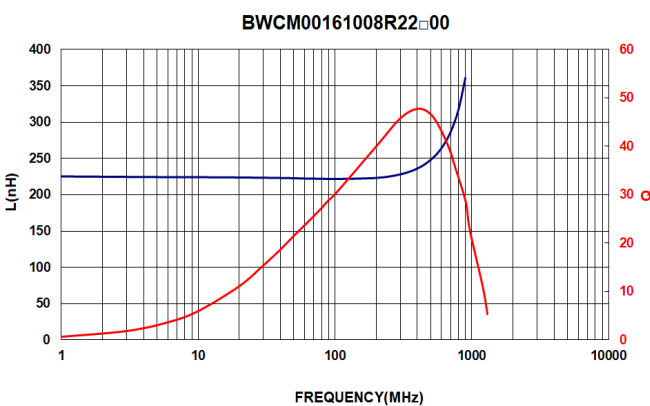
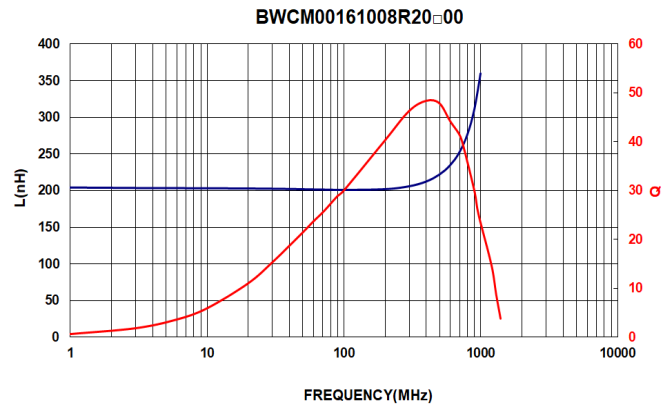
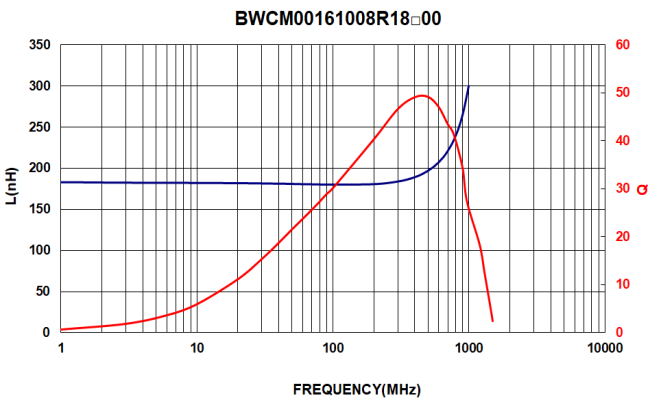
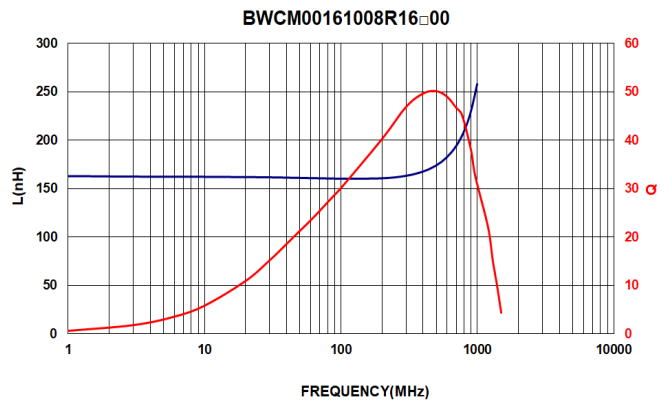
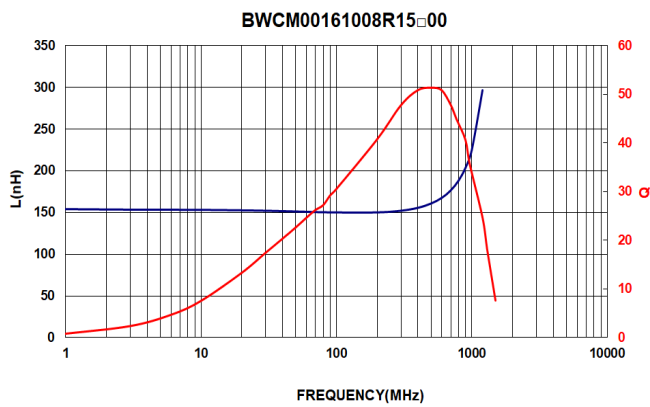
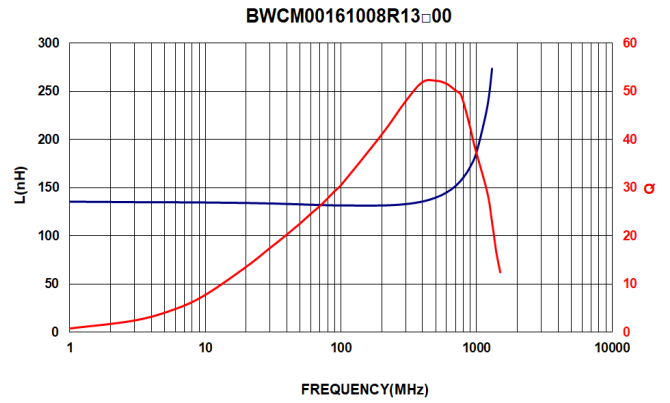
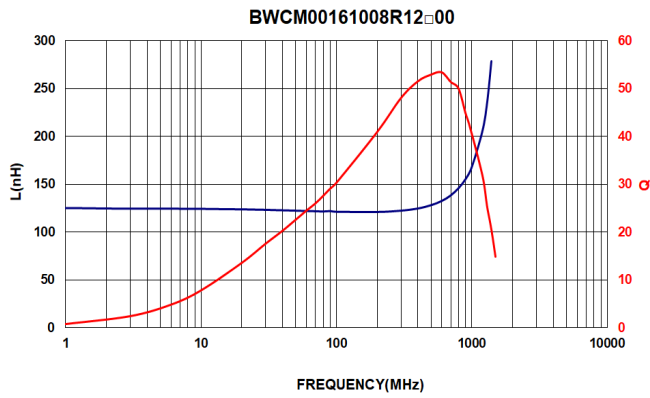

BWCM00161008 Series Specification

BWCM00161008R33-00

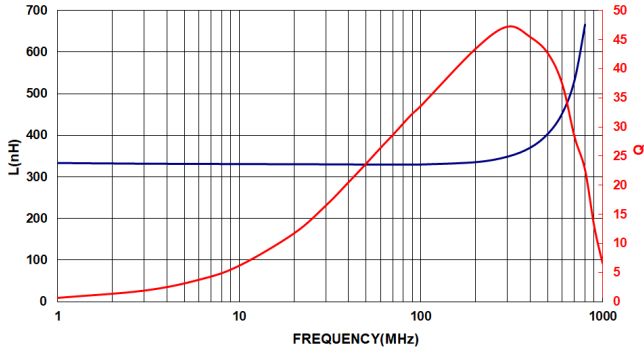

BWCM00161008R39-00

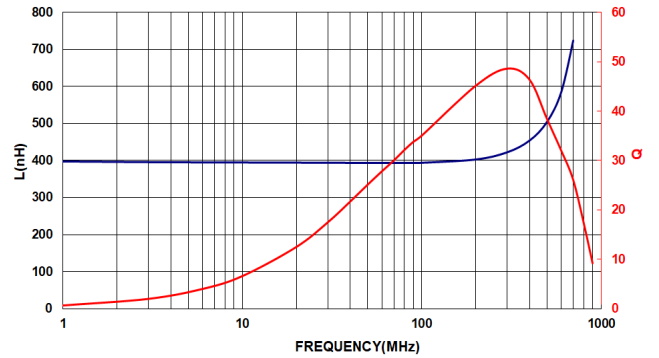

BWCM00161008R47-00

