

Power Inductor

Automotive Grade

APSA Series



Overview

Power inductors are passive electronic components used in various circuits to store energy in a magnetic field when electrical current flows through them. They are critical in filtering, energy storage, and noise suppression in power electronic systems. They are designed to handle higher currents and are optimized for minimal power loss and thermal efficiency.

Benefits

1. Automotive grade available
2. Ferrite SMD Shielded Type
3. No thermal aging

Applications

1. Automotive Systems for Infotainment, Dashboard, ADAS
2. IPC Equipment
3. Net working

Product Information

Series	L (mm)	W(mm)	T (mm)	Inductance (μH)
APSA	6.3	6.3	3.0	1.5 ~ 1500
	7.3	7.3	4.8	
	7.3	7.3	5.8	
	12.5	12.5	5.8	



1 Scope: This specification applies to SMD Shielded Power Inductors

2 Part Numbering:

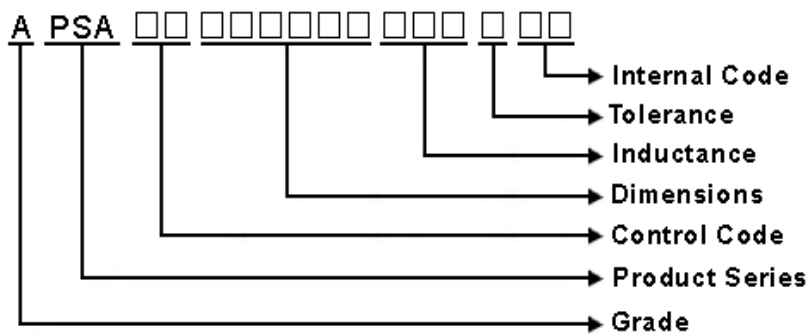

3 Rating:

Operating Temperature: - 40°C ~ + 125°C (Including self temp. rise)

Storage Temperature: - 40°C ~ + 125°C(For after the circuit board is mounted)

Storage Temperature: (on tape & reel): -20°C to +40°C; 75% RH max.

4 Marking:

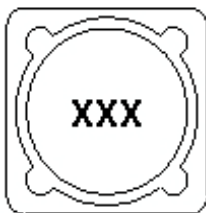

Ex Marking : 6R8

Marking color : Black

5 Standard Testing Condition

	Unless otherwise specified	In case of doubt
Temperature	Ordinary Temperature(15 to 35°C)	20 to 30°C
Humidity	Ordinary Humidity(25 to 85% RH)	50 to 80 %RH

APSA00070748 Series Specification

AEC-Q200

6 Configuration and Dimensions and Unit Weight:

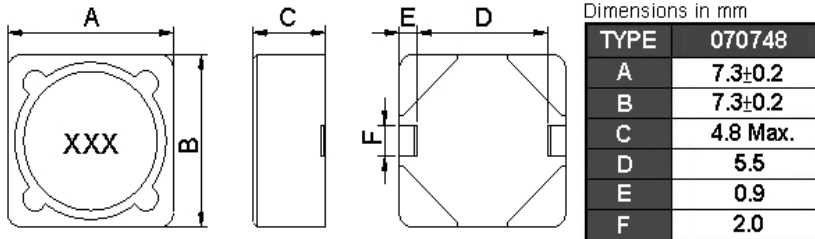

Net Weight (grms)

SIZE CODE	Net Weight (grms)
070748	0.98(Typ.)

7 Electrical Characteristics:

Part No.	Inductance (uH)	Test Freq.	SRF (MHz)Min.	RDC (mΩ)Max.	Isat (A)	Irms (A)	Tolerance (±%)	Marking
APSA000707483R3M00	3.3	100 kHz,1V	90	24	2.5	2.3	20	3R3
APSA000707484R7M00	4.7	100 kHz,1V	65	36	2	2.1	20	4R7
APSA000707486R8M00	6.8	100 kHz,1V	24	40	1.7	1.74	20	6R8
APSA00070748100M00	10	100 kHz,1V	17	43.2	1.3	1.78	20	100
APSA00070748150M00	15	100 kHz,1V	14	62.4	1.1	1.53	20	150
APSA00070748220M00	22	100 kHz,1V	10.5	73.2	0.9	1.34	20	220
APSA00070748330M00	33	100 kHz,1V	10	115	0.82	1.09	20	330
APSA00070748470M00	47	100 kHz,1V	8	150	0.75	0.92	20	470
APSA00070748680M00	68	100 kHz,1V	7	210	0.6	0.77	20	680
APSA00070748101M00	100	100 kHz,1V	6	300	0.5	0.65	20	101
APSA00070748151M00	150	100 kHz,1V	4	408	0.4	0.55	20	151
APSA00070748221M00	220	100 kHz,1V	3.5	624	0.33	0.45	20	221
APSA00070748331M00	330	100 kHz,1V	3	880	0.25	0.37	20	331
APSA00070748471M00	470	100 kHz,1V	2.5	1260	0.22	0.31	20	471
APSA00070748681M00	680	100 kHz,1V	2.1	1770	0.2	0.27	20	681

NOTE: □-tolerance M=±20%

1. Operating temperature range - 4 0 °C ~ 1 2 5 °C(Including self - temperature rise)
2. Isat for Inductance drop 10% from its value without current.
3. I rms for a 20°C temperature rise from 25°C ambient.
4. The actual use current is suggested not to be out of Isat*80%

8 APSA00070748 Series

8.1 Construction:

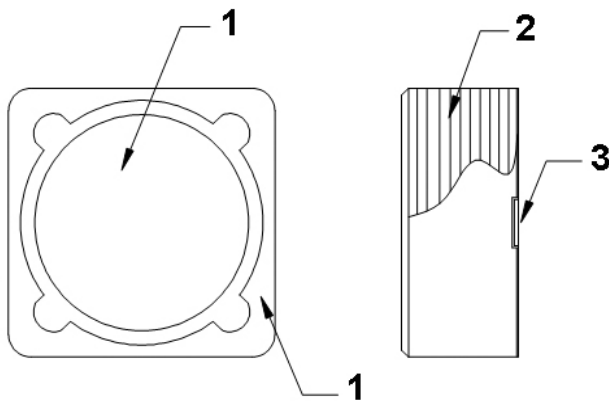

8.2 Material List:

No	Part	Material
1	Core	Ferrite
2	Wire	Magnet Wire
3	Terminal	Terminal Copper

9 Reliability Of Ferrite Wire Wound Power Inductor

1-1.Mechanical Performance

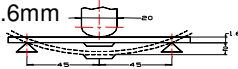
No	Item	Specification	Test Method
1-1-1	Board Flex	The forces applied on the right conditions must not damage the terminal electrode and the ferrite	Refer to AEC-Q200-005 Test device shall be soldered on the substrate Substrate Dimension: 100x40x1.6mm Deflection: 2.0mm Keeping Time: 60sec 
1-1-2	Resistance to Soldering Heat	Appearance: No damage Inductance change shall be within $\pm 10\%$.	Refer to MIL-STD-202 Method 210 Pre-heating: 150°C, 1min Solder Composition: Sn/Ag3.0/Cu0.5(Pb-Free) Solder Temperature: 250 \pm 5°C Immersion Time: 10 \pm 1sec
1-1-3	Solder ability	The electrodes shall be at least 95% covered with new solder coating	Refer to J-STD-002 Pre-heating: 150°C, 1min Solder Composition: Sn/Ag3.0/Cu0.5(Pb-Free) Solder Temperature: 245 \pm 5°C (Pb-Free) Immersion Time: 4 \pm 1sec
1-1-4	Terminal Strength Test	Appearance: No damage	Refer AEC-Q200-006 Soldered on PCB for testing as fig. Force : 1.8kg Keeping Time: 60 seconds.
1-1-5	Resistance to Solvent	There must be no change in appearance or obliteration of marking	Refer to MIL-STD-202 Method 215 Inductors must withstand 6 minutes of alcohol or water Sample Size : 15 pcs
1-1-6	Vibration	Appearance: No damage Inductance change shall be within $\pm 10\%$.	Refer MIL-STD-202 Method 204 Vibration waveform: Sine waveform Vibration frequency: 10Hz~2000Hz Vibration acceleration: 5g Sweep rate: 0.764386octave/minute Duration of test: 12 cycles each of 3 orientations, 20 minutes for each cycle Vibration axes: X, Y & Z

1-2.Environmental Performance

No	Item	Specification	Test Method
1-2-1	Temperature Cycle	Appearance: No damage Inductance change shall be within $\pm 30\%$	Refer to JESD Method JA-104 Total cycles: 1000 cycles Temperature Cycling Test Conditions : -40 to +125 °C -40 °C Soak Mode Condition : 30 minutes 125 °C Soak Mode Condition : 30 minutes Measured after exposure in the room condition for 24hrs
1-2-2	Biased Humidity Resistance		Refer to MIL-STD-202 Method 103 Temperature: 85 \pm 2°C Relative Humidity:85% / Time: 1000hrs Measured after exposure in the room condition for 24hrs
1-2-3	High Temperature Exposure (Storage)		Refer to MIL-STD-202 Method 108 Temperature: 125 \pm 3°C Time: 1000hrs Measured after exposure in the room condition for 24hrs
1-2-4	Operational Life		Refer to MIL-STD-202 Method 108 Temperature: 125 \pm 3°C Applied Current : Rated Current Time: 1000hrs Measured after exposure in the room condition for 24hrs

Reflow Soldering Profile

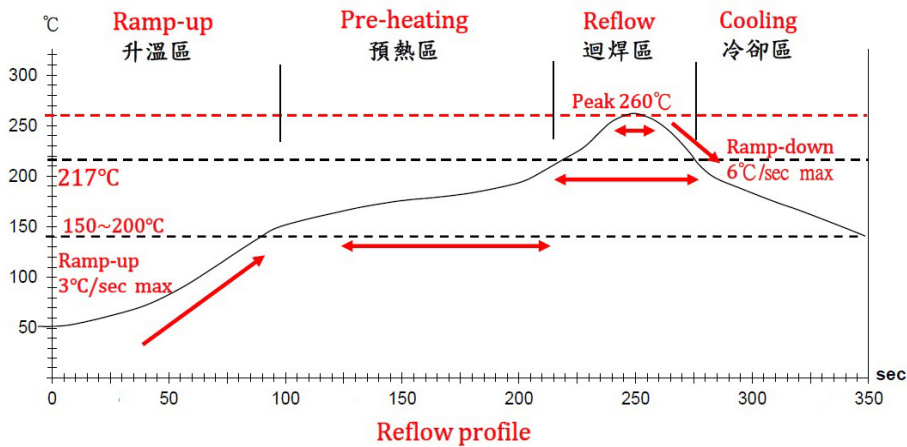

Lead-Free(LF)標準溫度分析範圍

Refer to J-STD-020C

管制項目 Item.	升溫區 Ramp-up	預熱區 Pre-heating	迴焊區 Reflow	Peak Temp	冷卻區 Cooling
溫度範圍 Temp.scope	R.T ~ 150°C	150°C ~ 200°C	217°C	260±5°C	Peak Temp.~150°C
標準時間 Time spec.	-	60 ~ 180 sec	60 ~ 150 sec	20 ~ 40 sec	-
實際時間 Time result	-	75 ~ 100 sec	90 ~ 120 sec	20 ~ 35 sec	-

11 Packaging:

11.1 Packaging -Cover Tape

The force for tearing off cover tape is 10 to 130 grams in the arrow direction.

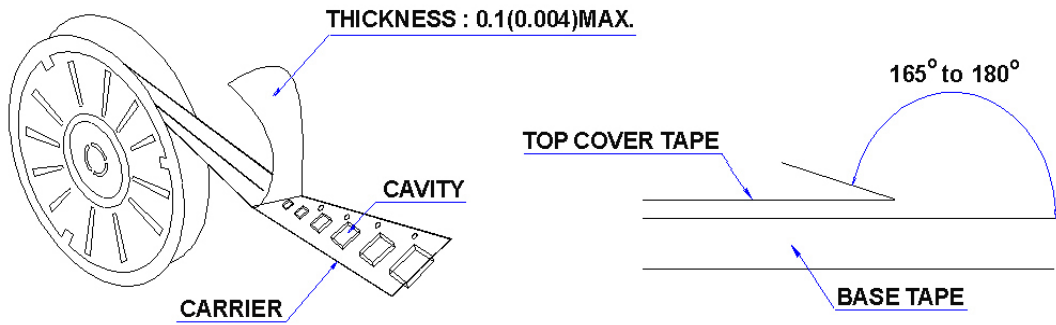

11.2 Packaging Quantity

TYPE	PCS/REEL
070748	1000

11.3 Reel Dimensions

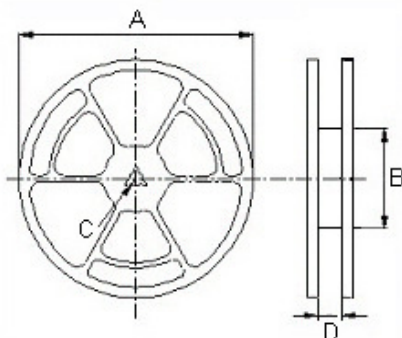

Dimensions in mm

TYPE	A	B	C	D
070748	330	100	13	16

11 Packaging:

11.4 Tape Dimensions in mm

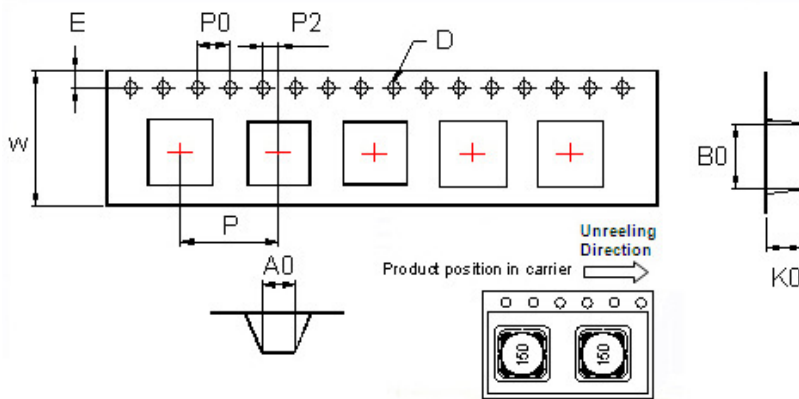

TYPE	A0	B0	K0	D	E	W	P	P0	P2
070748	7.6	7.6	5.2	1.55	1.75	16	12	4	2

12 Recommended Land Pattern:

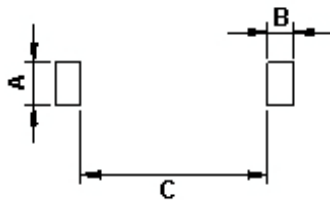

Dimensions in mm

TYPE	A	B	C
070748	2.2	1.5	4.8

13 Note:

1. Please make sure that your product has been evaluated and confirmed against your specifications when our product is mounted to your product.
2. Do not knock nor drop.
3. All the items and parameters in this product specification have been prescribed on the premise that our product is used for the purpose, under the condition and in the environment agreed upon between you and us. You are requested not to use our product deviating from such agreement.
4. Please keep the distance between transformer/coil and other components (refer to the standard IEC 950)
5. The moisture sensitivity level (MSL) of products is classified as level 1.

14 Graph:

APSA000707483R3M00

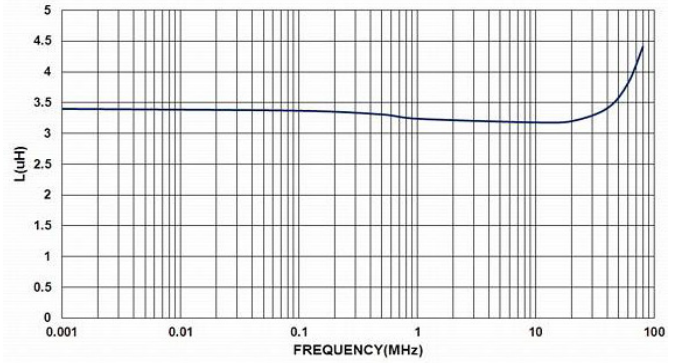
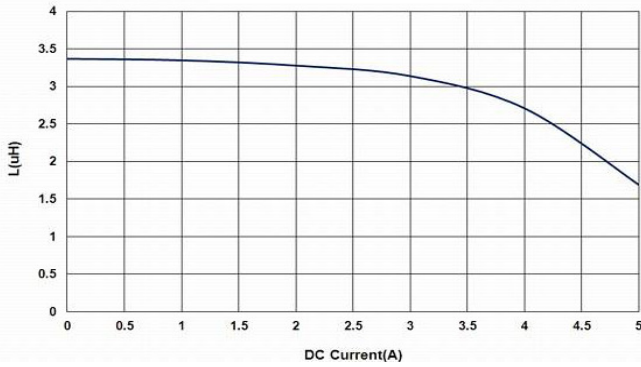

APSA000707484R7M00

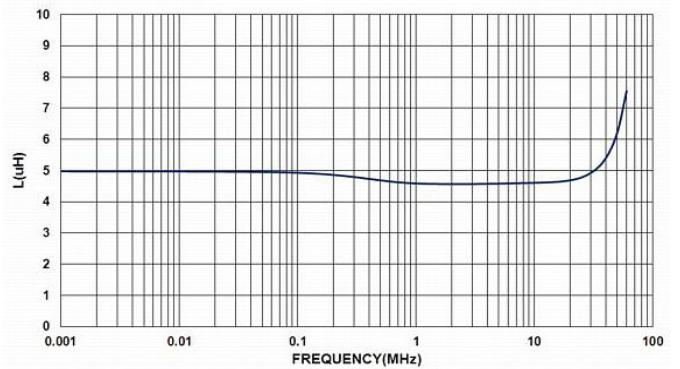
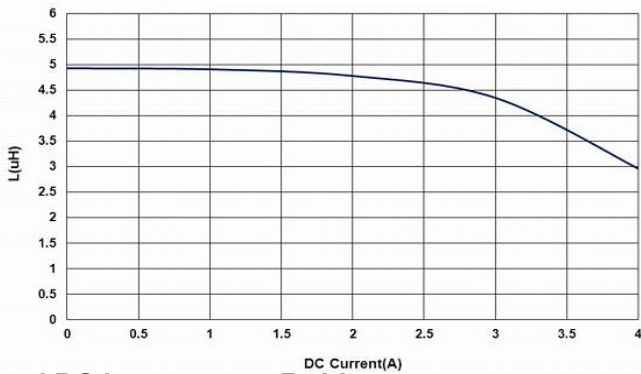

APSA000707486R8M00

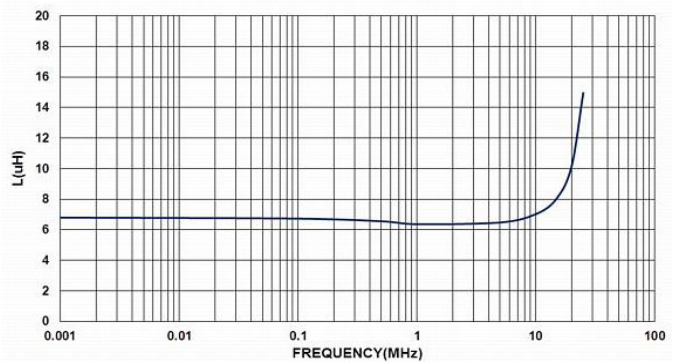
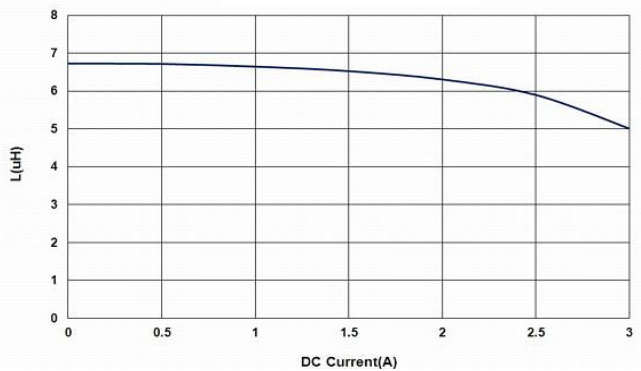

APSA00070748100M00

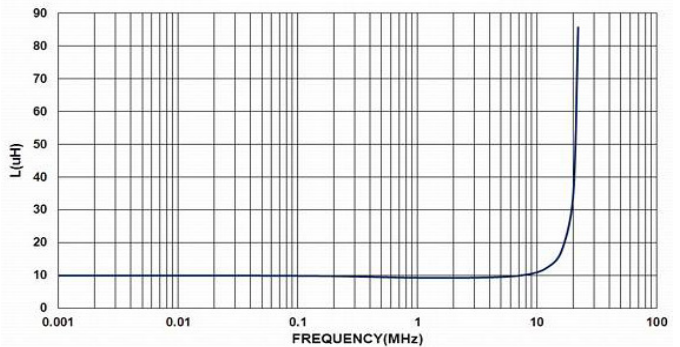
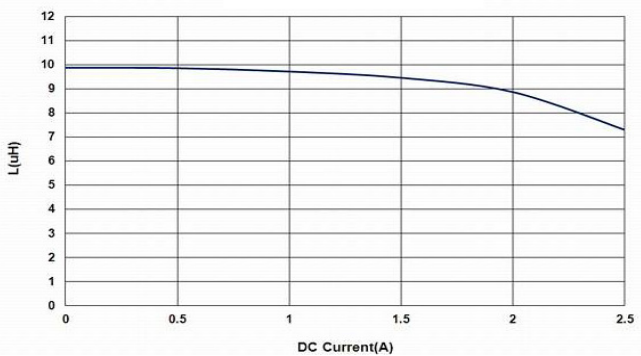

14 Graph:

APSA00070748150M00

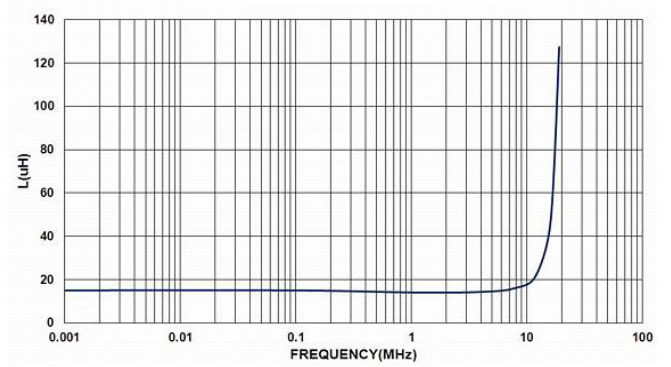
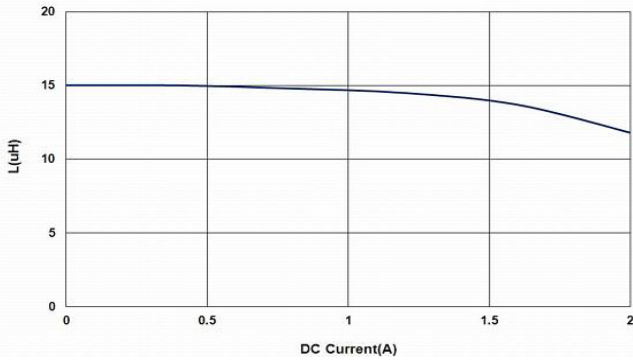

APSA00070748220M00

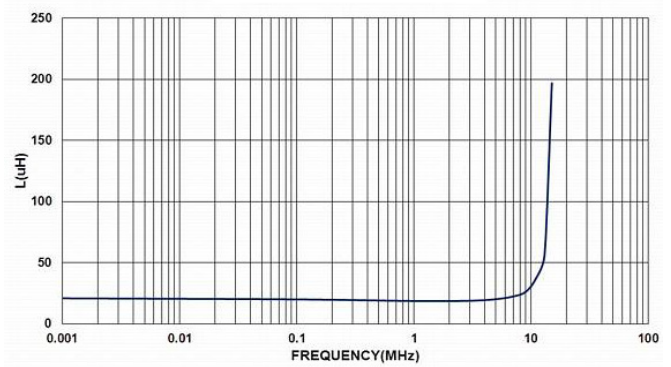
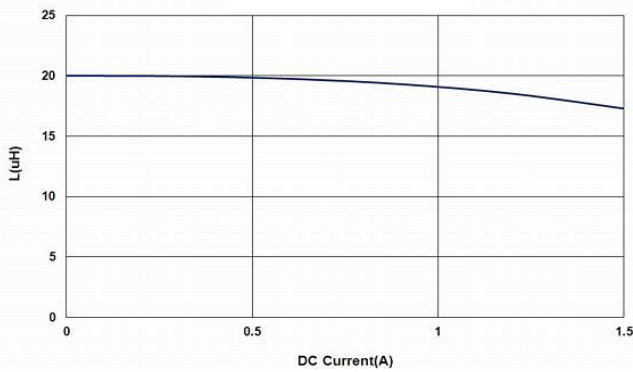

APSA00070748330M00

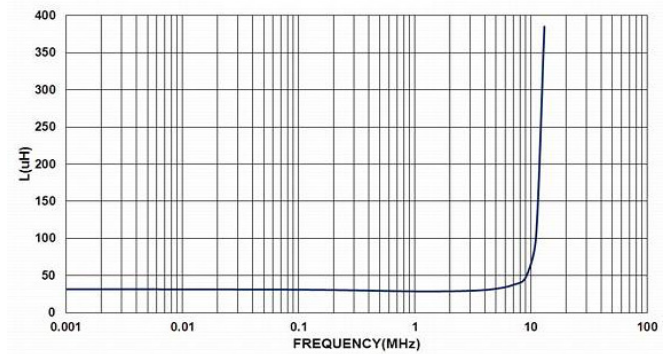
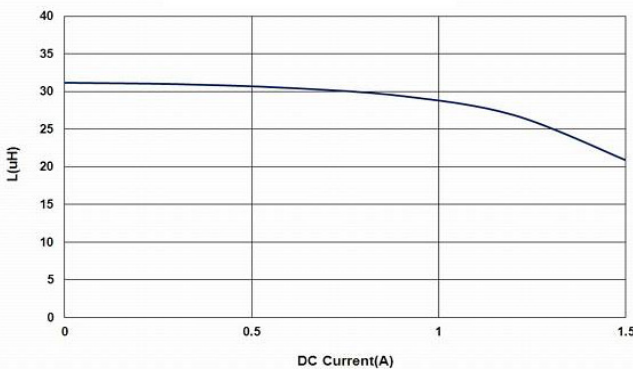

APSA00070748470M00

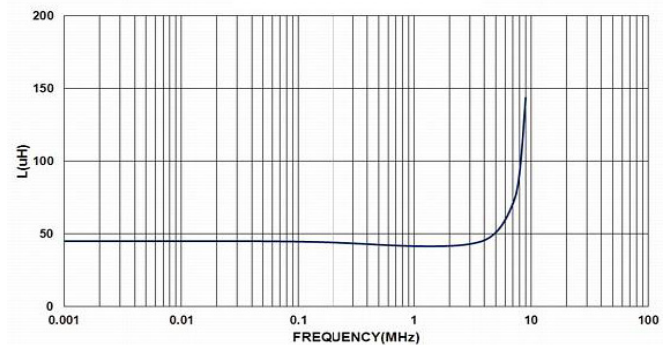
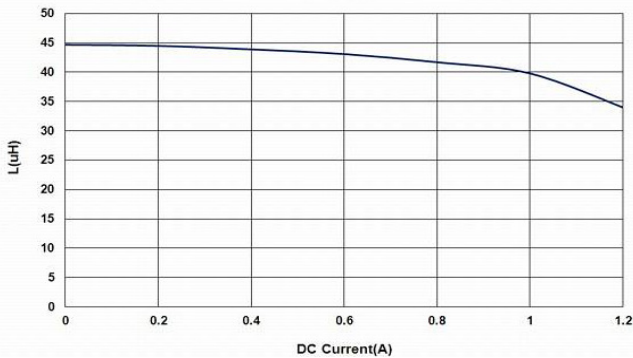

14 Graph:

APSA00070748680M00

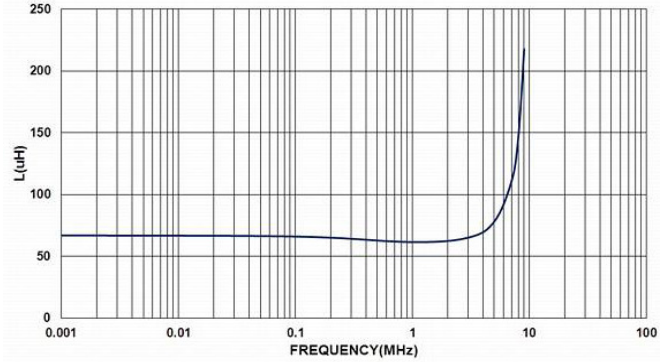
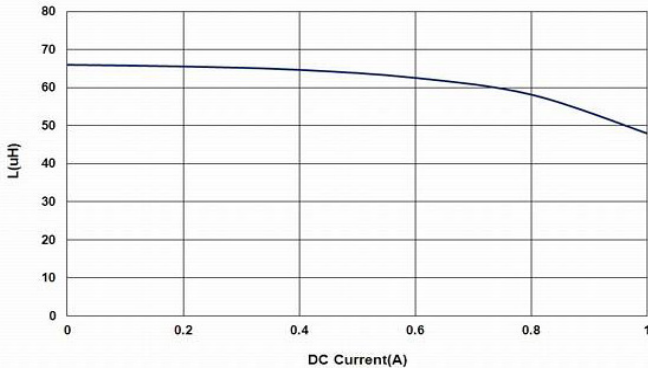

APSA00070748101M00

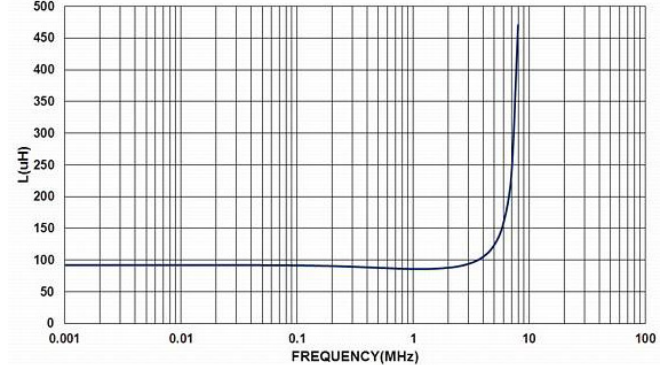
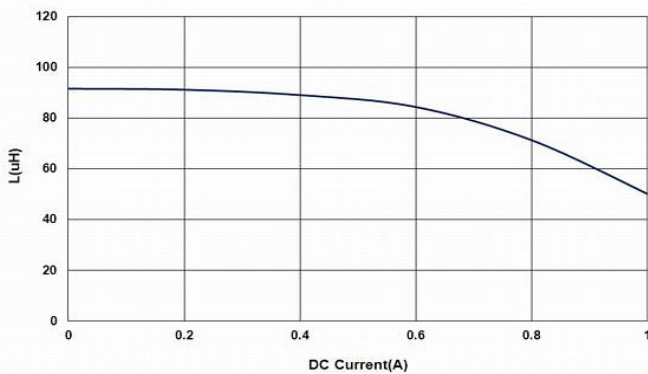

APSA00070748151M00

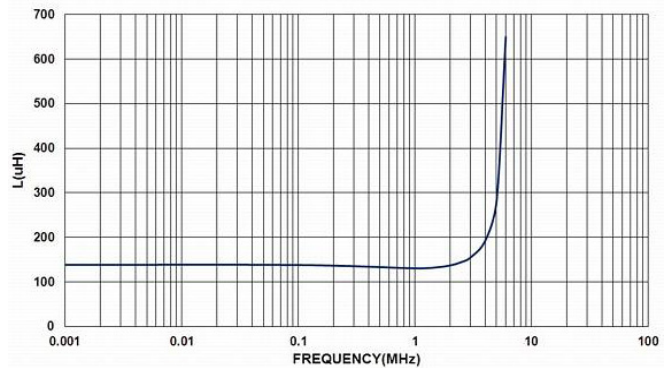
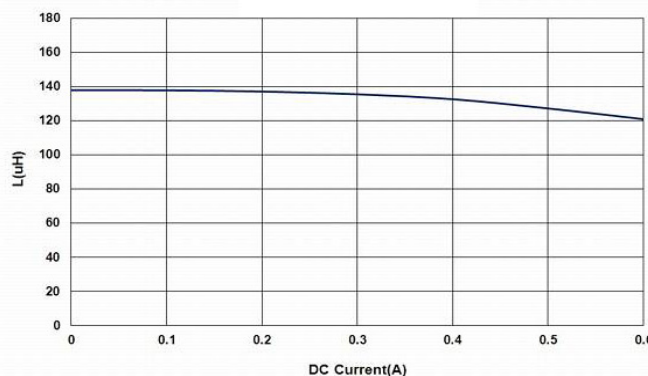

APSA00070748221M00

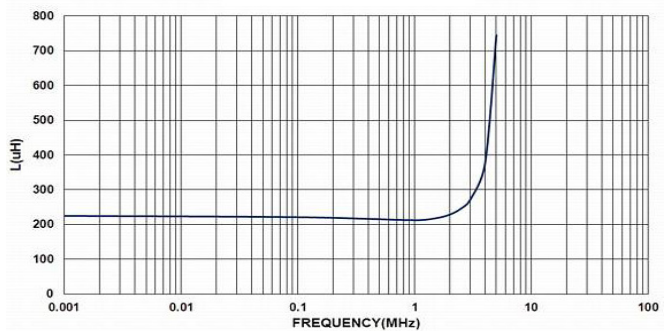

APSA00070748 Series Specification

AEC-Q200

14 Graph:

APSA00070748331M00

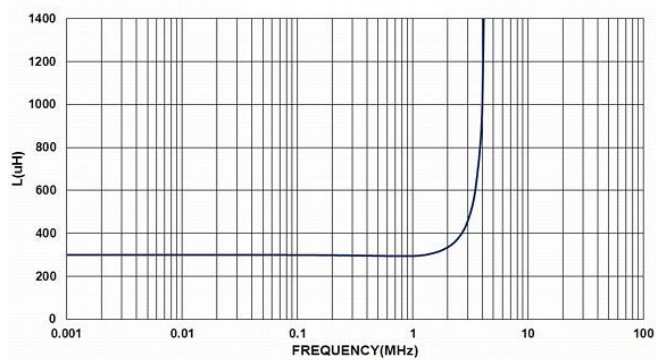
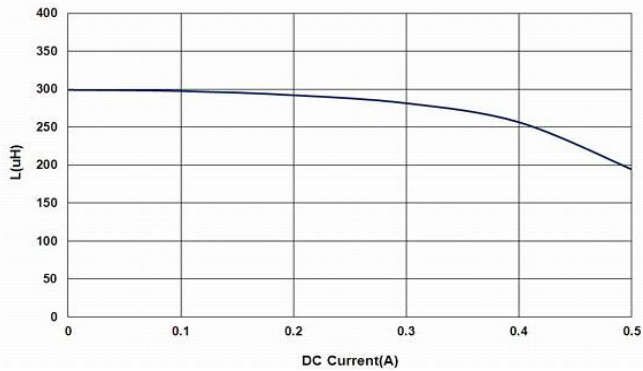

APSA00070748471M00

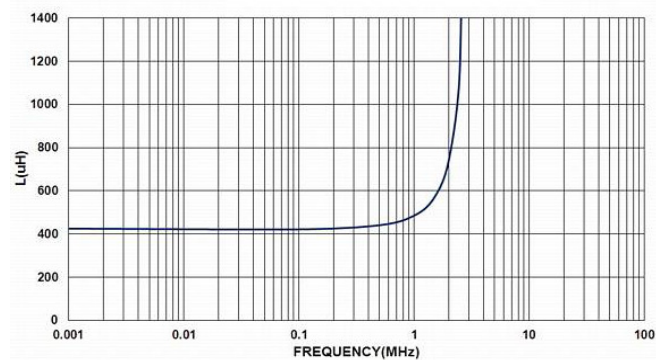
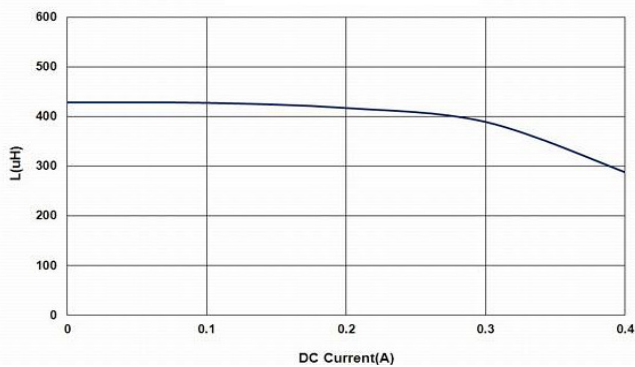

APSA00070748681M00

