

Power Inductor

Automotive Grade

APSC Series



Overview

Power inductors are passive electronic components used in various circuits to store energy in a magnetic field when electrical current flows through them. They are critical in filtering, energy storage, and noise suppression in power electronic systems.

They are designed to handle higher currents and are optimized for minimal power loss and thermal efficiency.

Benefits

1. Automotive grade available
2. Ferrite SMD Shielded Type
3. No thermal aging

Applications

1. Automotive Systems for Infotainment, Dashboard, ADAS
2. IPC Equipment
3. Net working

Product Information

Series	L (mm)	W(mm)	T (mm)	Inductance (μH)
APSC	3.2	3.2	1.6	0.47 ~ 1000
	4.0	4.0	1.8	
	4.0	4.0	3.0	
	4.7	4.7	2.0	
	4.7	4.7	3.0	
	4.7	4.7	4.0	
	5.7	5.7	2.0	
	5.7	5.7	3.0	
	6.7	6.7	3.0	
	7.0	7.0	4.0	
	7.5	7.5	4.6	
	10.3	10.5	3.1	
	10.3	10.5	4.0	
	10.3	10.5	5.1	
	12.5	12.5	4.5	
12.5	12.5	6.0		
12.5	12.5	8.0		



1 Scope: This specification applies to SMD Shielded Power Inductors

2 Part Numbering:

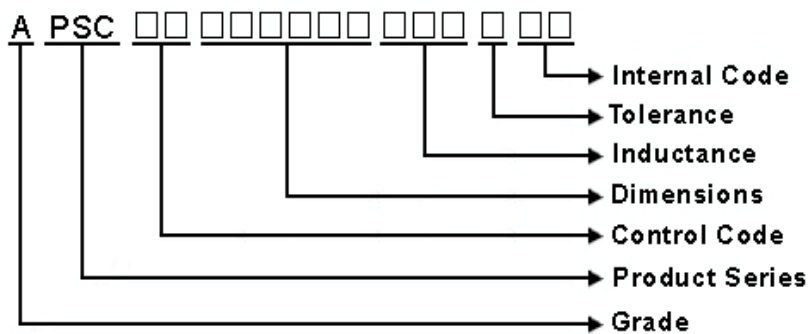

3 Rating:

Operating Temperature: - 40°C ~ + 125°C (Including self temp. rise)

Storage Temperature: - 40°C ~ + 125°C(For after the circuit board is mounted)

Storage Temperature: (on tape & reel): -20°C to +40°C; 75% RH max.

4 Marking:

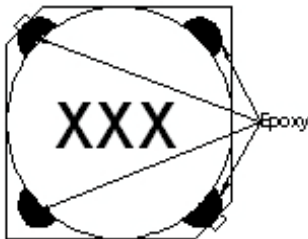

Ex Marking : 3R3

Marking color : Black

5 Standard Testing Condition

	Unless otherwise specified	In case of doubt
Temperature	Ordinary Temperature(15 to 35°C)	20 to 30°C
Humidity	Ordinary Humidity(25 to 85% RH)	50 to 80 %RH

APSC00060620 Series Specification

AEC-Q200

6 Configuration and Dimensions and Unit Weight:

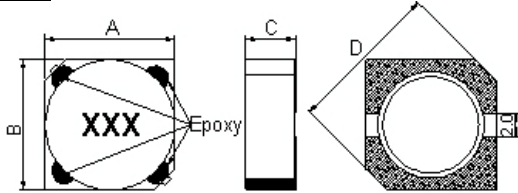

Dimensions in mm

TYPE	A	B	C	D
060620	5.7±0.3	5.7±0.3	2 Max.	8.2Max.

Net Weight (grms)

SIZE CODE	Net Weight (grms)
060620	0.3(Typ.)

7 Electrical Characteristics:

Part No.	Inductance (uH)	Test Freq.	RDC (Ω)Max.	Isat(A) Max(Typ)	Tolerance (±%)	Marking
APSC000606201R0□S0	1	10 kHz,1 V	0.038	2.80(3.50)	30	1R0
APSC000606201R5□S0	1.5	10 kHz,1 V	0.038	2.50(3.00)	30	1R5
APSC000606202R0□S0	2	10 kHz,1 V	0.045	2.10(2.60)	30	2R0
APSC000606202R2□S0	2.2	10 kHz,1 V	0.048	2.00(2.50)	30	2R2
APSC000606203R3□S0	3.3	10 kHz,1 V	0.056	1.70(2.00)	30	3R3
APSC000606204R1□S0	4.1	10 kHz,1 V	0.057	1.55(1.90)	30	4R1
APSC000606204R7□S0	4.7	10 kHz,1 V	0.076	1.35(1.70)	30	4R7
APSC000606205R4□S0	5.4	10 kHz,1 V	0.076	1.20(1.50)	30	5R4
APSC000606206R2□S0	6.2	10 kHz,1 V	0.096	1.10(1.40)	30	6R2
APSC000606206R8□S0	6.8	10 kHz,1 V	0.1	1.00(1.30)	30	6R8
APSC000606208R9□S0	8.9	10 kHz,1 V	0.116	0.95(1.25)	30	8R9
APSC00060620100□S0	10	10 kHz,1 V	0.124	0.90(1.20)	20,30	100
APSC00060620120□S0	12	10 kHz,1 V	0.153	0.90(1.00)	30	120
APSC00060620150□S0	15	10 kHz,1 V	0.196	0.80(0.91)	20,30	150
APSC00060620180□S0	18	10 kHz,1 V	0.21	0.75(0.90)	30	180
APSC00060620220□S0	22	10 kHz,1 V	0.29	0.65(0.80)	20,30	220
APSC00060620270□S0	27	10 kHz,1 V	0.33	0.60(0.70)	30	270
APSC00060620330□S0	33	10 kHz,1 V	0.386	0.55(0.65)	20,30	330
APSC00060620390□S0	39	10 KHz,1 V	0.52	0.48(0.60)	30	390
APSC00060620470□S0	47	10 kHz,1 V	0.595	0.44(0.51)	20,30	470
APSC00060620560□S0	56	10 kHz,1 V	0.665	0.40(0.50)	30	560
APSC00060620680□S0	68	10 kHz,1 V	0.84	0.33(0.43)	30	680
APSC00060620820□S0	82	10 kHz,1 V	0.978	0.30(0.41)	30	820
APSC00060620101□S0	100	10 kHz,1 V	1.2	0.25(0.36)	20,30	101

NOTE: □-tolerance M=±20% / T=±30%

1. Operating temperature range - 4 0 °C ~ 1 2 5 °C (Including self - temperature rise)
2. Isat for Inductance drop 35% from its value without current.
3. RDC test method: place testing device to the 2 solder ends of winding and test the value.
4. The actual use current is suggested not to be out of Isat*80%

8 APSC00060620 Series

8.1 Construction:

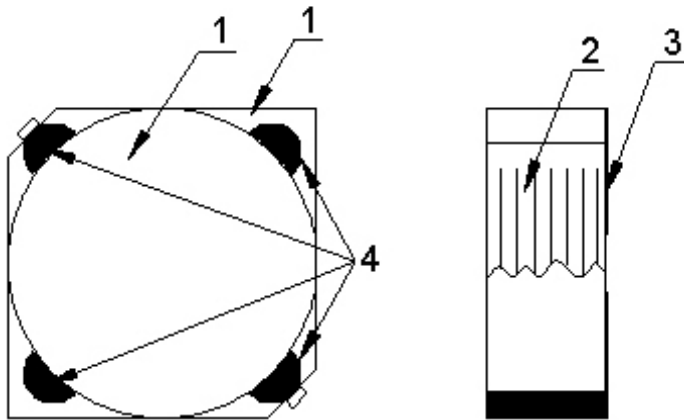

8.2 Material List:

No	Part	Material
1	Core	Ferrite
2	Wire	Magnet Wire
3	Terminal	Terminal Copper
4	Epoxy	Epoxy Resin

9 Reliability Of Ferrite Wire Wound Power Inductor

1-1.Mechanical Performance

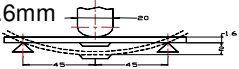
No	Item	Specification	Test Method
1-1-1	Board Flex	The forces applied on the right conditions must not damage the terminal electrode and the ferrite	Refer to AEC-Q200-005 Test device shall be soldered on the substrate Substrate Dimension: 100x40x1.6mm Deflection: 2.0mm Keeping Time: 60sec 
1-1-2	Resistance to Soldering Heat	Appearance: No damage Inductance change shall be within $\pm 10\%$.	Refer to MIL-STD-202 Method 210 Pre-heating: 150°C, 1min Solder Composition: Sn/Ag3.0/Cu0.5(Pb-Free) Solder Temperature: 250 \pm 5°C Immersion Time: 10 \pm 1sec
1-1-3	Solder ability	The electrodes shall be at least 95% covered with new solder coating	Refer to J-STD-002 Pre-heating: 150°C, 1min Solder Composition: Sn/Ag3.0/Cu0.5(Pb-Free) Solder Temperature: 245 \pm 5°C (Pb-Free) Immersion Time: 4 \pm 1sec
1-1-4	Terminal Strength Test	Appearance: No damage	Refer AEC-Q200-006 Soldered on PCB for testing as fig. Force : 1.8kg Keeping Time: 60 seconds.
1-1-5	Resistance to Solvent	There must be no change in appearance or obliteration of marking	Refer to MIL-STD-202 Method 215 Inductors must withstand 6 minutes of alcohol or water Sample Size : 15 pcs
1-1-6	Vibration	Appearance: No damage Inductance change shall be within $\pm 10\%$.	Refer MIL-STD-202 Method 204 Vibration waveform: Sine waveform Vibration frequency: 10Hz~2000Hz Vibration acceleration: 5g Sweep rate: 0.764386octave/minute Duration of test: 12 cycles each of 3 orientations, 20 minutes for each cycle Vibration axes: X, Y & Z

1-2.Environmental Performance

No	Item	Specification	Test Method
1-2-1	Temperature Cycle	Appearance: No damage Inductance change shall be within $\pm 30\%$	Refer to JESD Method JA-104 Total cycles: 1000 cycles Temperature Cycling Test Conditions : -40 to +125 °C -40 °C Soak Mode Condition : 30 minutes 125 °C Soak Mode Condition : 30 minutes Measured after exposure in the room condition for 24hrs
1-2-2	Biased Humidity Resistance		Refer to MIL-STD-202 Method 103 Temperature: 85 \pm 2°C Relative Humidity:85% / Time: 1000hrs Measured after exposure in the room condition for 24hrs
1-2-3	High Temperature Exposure (Storage)		Refer to MIL-STD-202 Method 108 Temperature: 125 \pm 3°C Time: 1000hrs Measured after exposure in the room condition for 24hrs
1-2-4	Operational Life		Refer to MIL-STD-202 Method 108 Temperature: 125 \pm 3°C Applied Current : Rated Current Time: 1000hrs Measured after exposure in the room condition for 24hrs

Reflow Soldering Profile

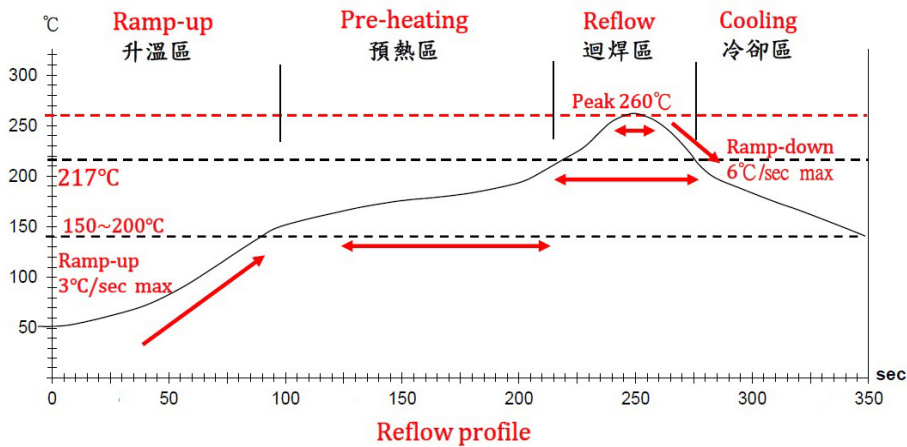

Lead-Free(LF)標準溫度分析範圍

Refer to J-STD-020C

管制項目 Item.	升溫區 Ramp-up	預熱區 Pre-heating	迴焊區 Reflow	Peak Temp	冷卻區 Cooling
溫度範圍 Temp.scope	R.T ~ 150°C	150°C ~ 200°C	217°C	260±5°C	Peak Temp.~150°C
標準時間 Time spec.	-	60 ~ 180 sec	60 ~ 150 sec	20 ~ 40 sec	-
實際時間 Time result	-	75 ~ 100 sec	90 ~ 120 sec	20 ~ 35 sec	-

10 Packaging:

10.1 Packaging -Cover Tape

The force for tearing off cover tape is 10 to 130 grams in the arrow direction.

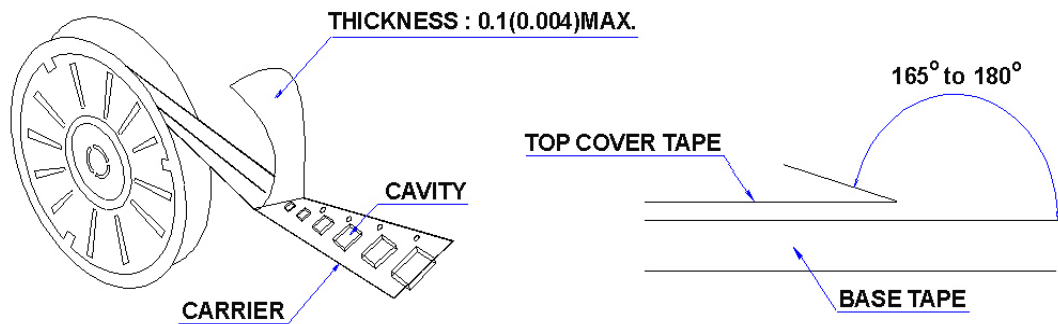

10.2 Packaging Quantity

TYPE	PCS/REEL
060620	1500

10.3 Reel Dimensions

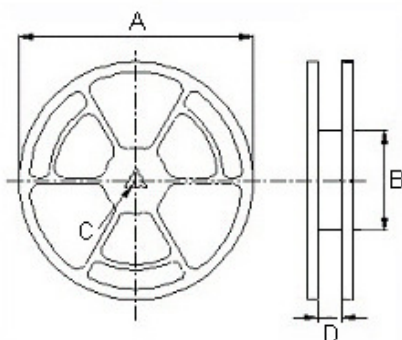

Dimensions in mm

TYPE	A	B	C	D
060620	330	100	13	13.4

10 Packaging:

10.4 Tape Dimensions in mm

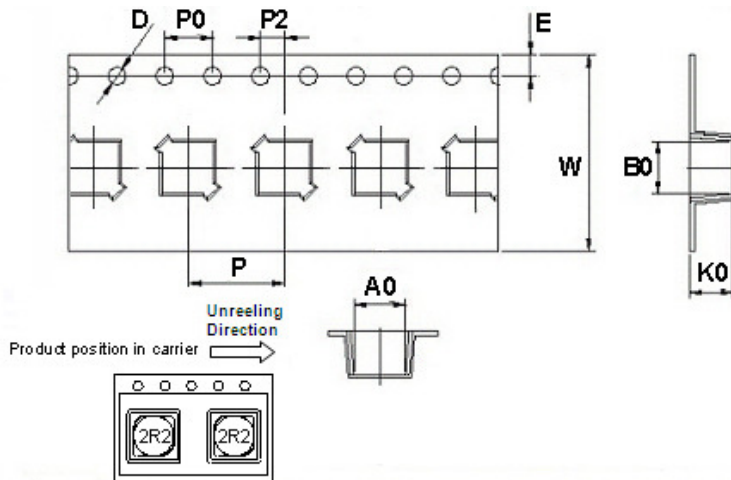

TYPE	A0	B0	K0	D	E	W	P	P0	P2
060620	6.2	6.2	2.2	1.55	1.75	16	12	4	2

11 Recommended Land Pattern:

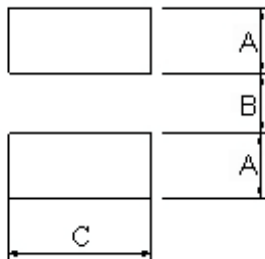

Dimensions in mm

TYPE	A	B	C
060620	2.15	2.0	6.3

12 Note:

1. Please make sure that your product has been evaluated and confirmed against your specifications when our product is mounted to your product.
2. Do not knock nor drop.
3. All the items and parameters in this product specification have been prescribed on the premise that our product is used for the purpose, under the condition and in the environment agreed upon between you and us. You are requested not to use our product deviating from such agreement.
4. Please keep the distance between transformer/coil and other components (refer to the standard IEC 950)
5. The moisture sensitivity level (MSL) of products is classified as level 1.

13 Graph:

APSC000606201R0□S0

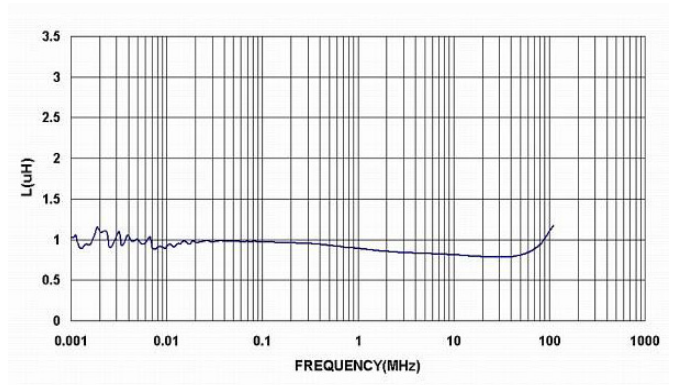
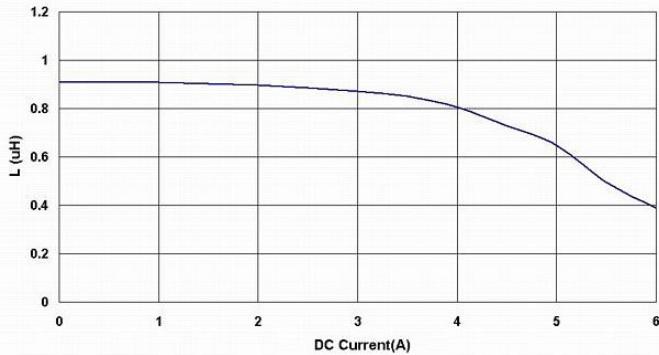

APSC000606201R5□S0

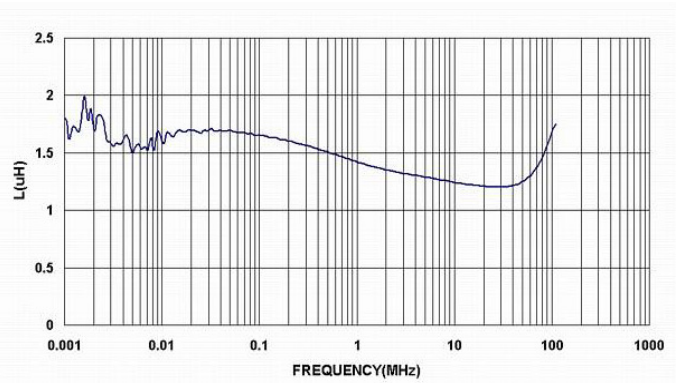
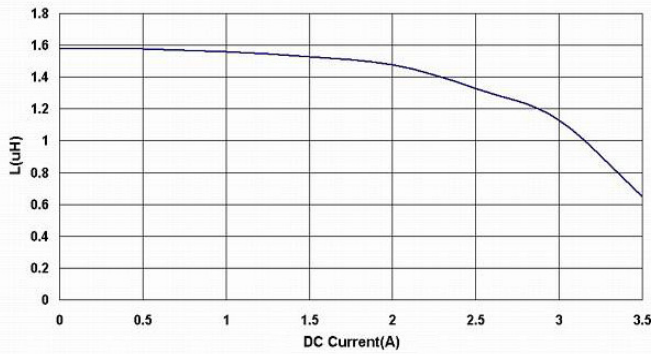

APSC000606202R2□S0

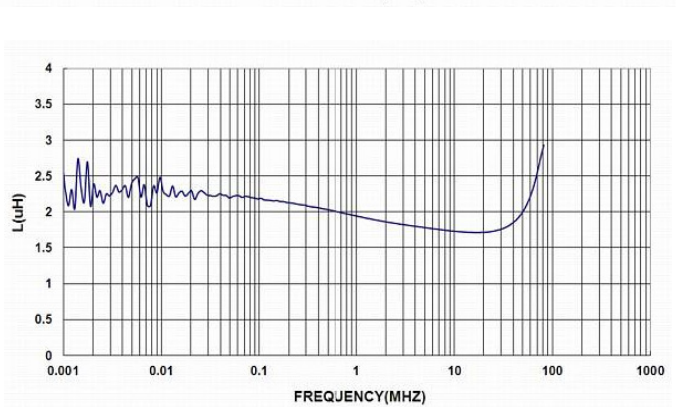
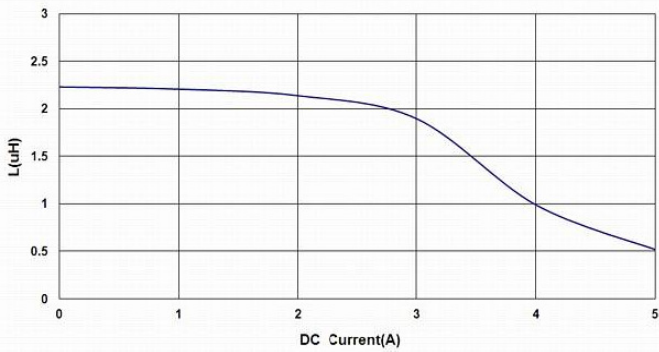

APSC00060620101□S0

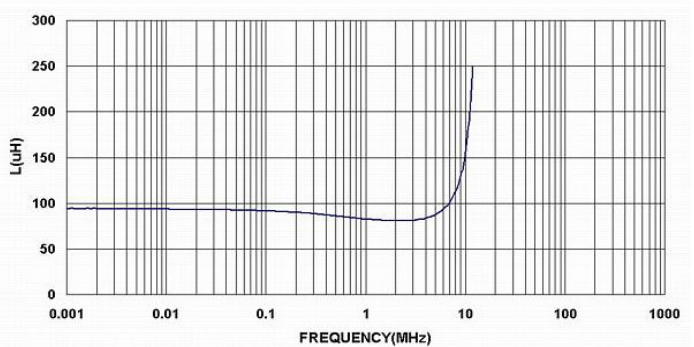
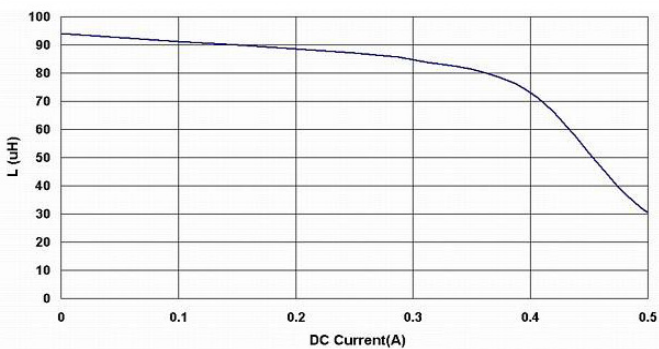

13 Graph:

APSC000606203R3□S0

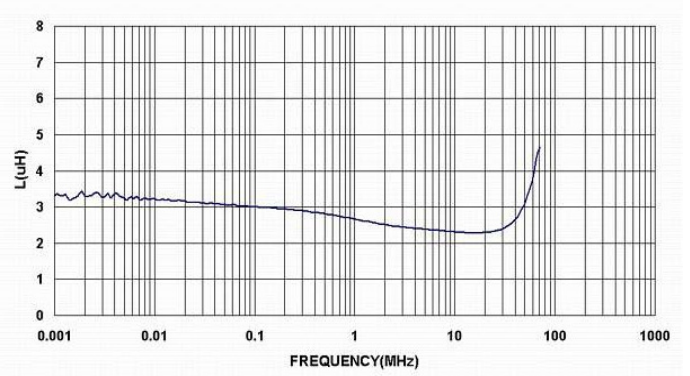
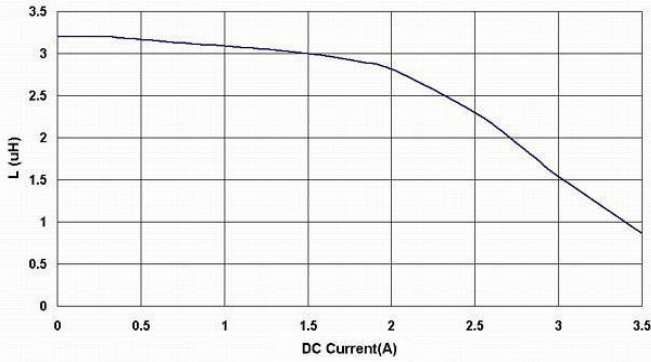

APSC000606204R1□S0

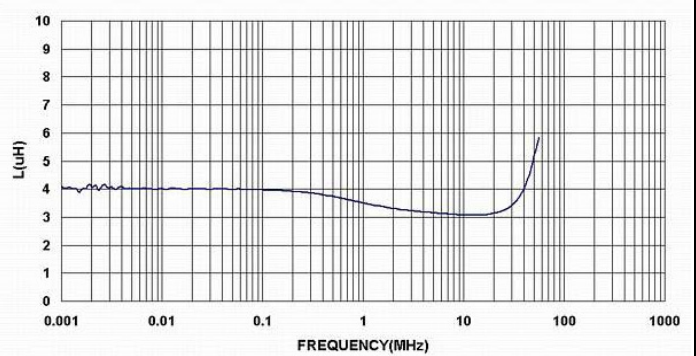
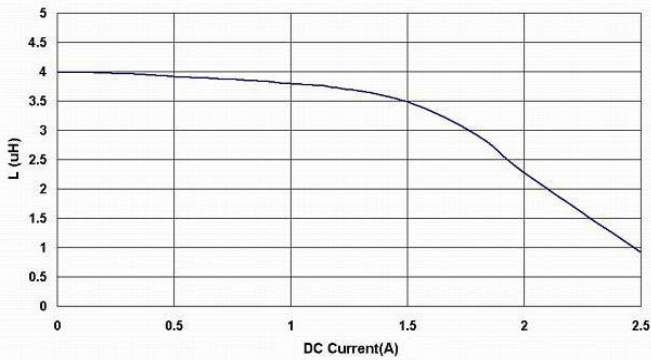

APSC000606204R7□S0

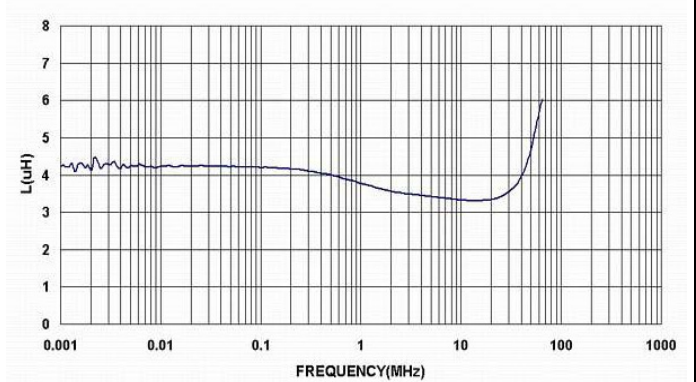
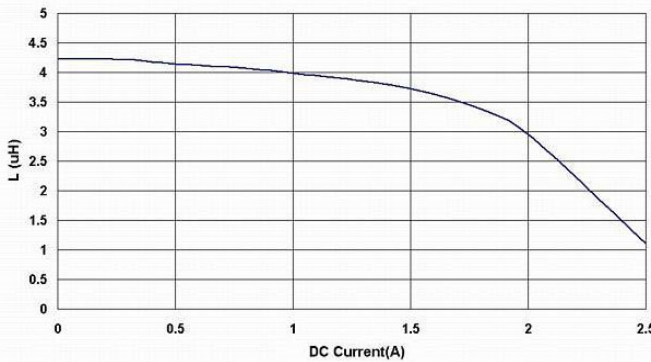

APSC000606205R4□S0

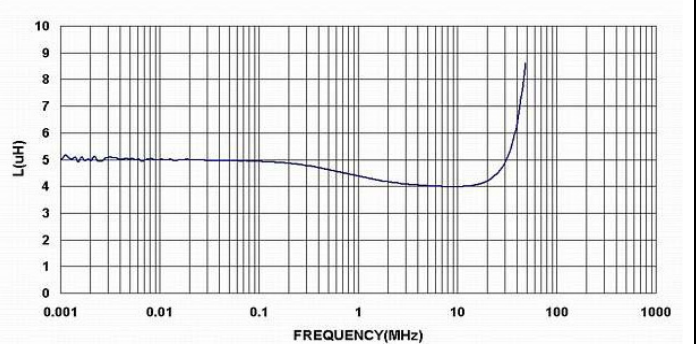
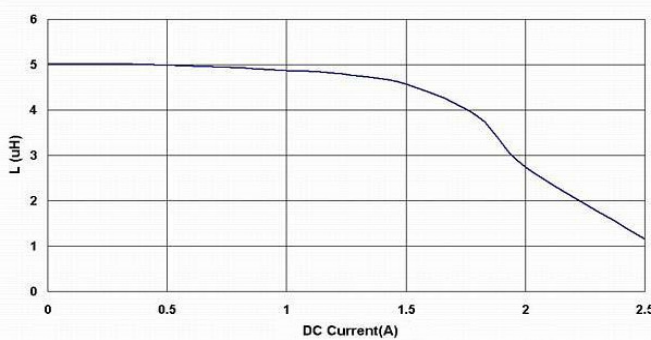

13 Graph:

APSC000606206R2□S0

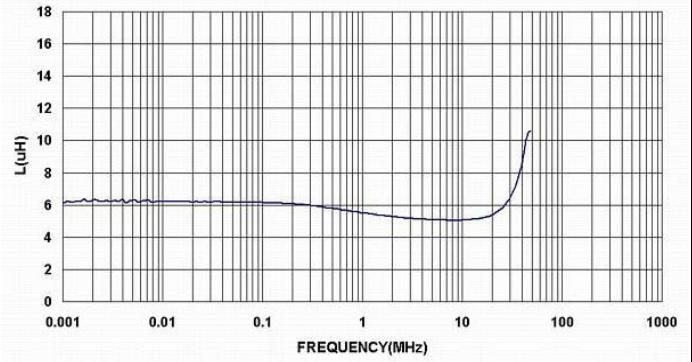
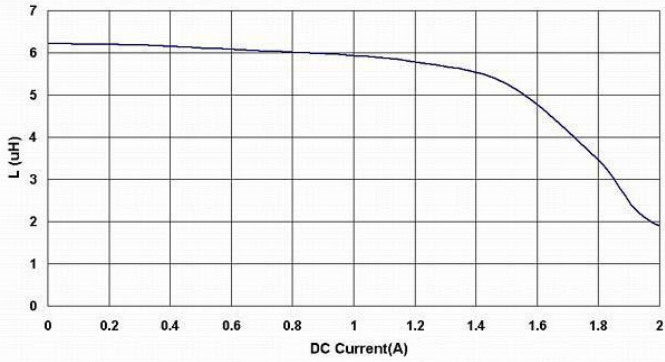

APSC000606206R8□S0

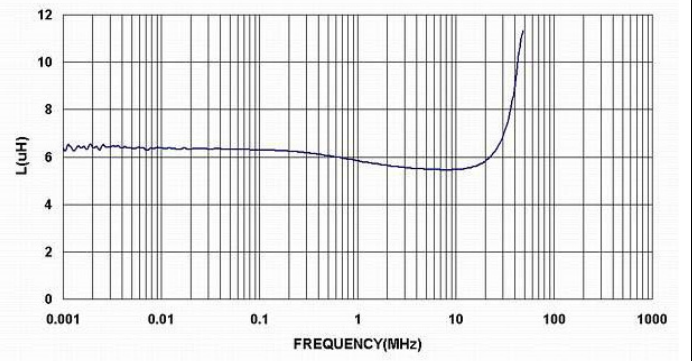
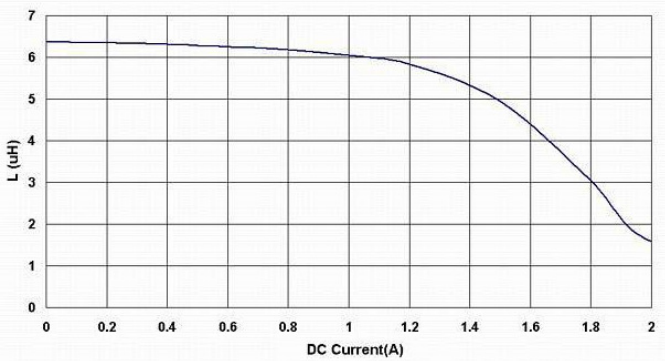

APSC000606208R9□S0

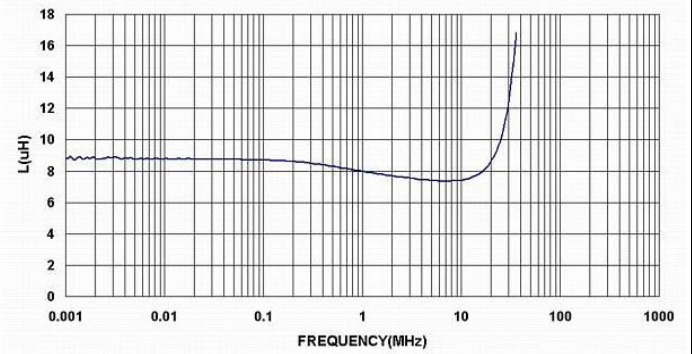
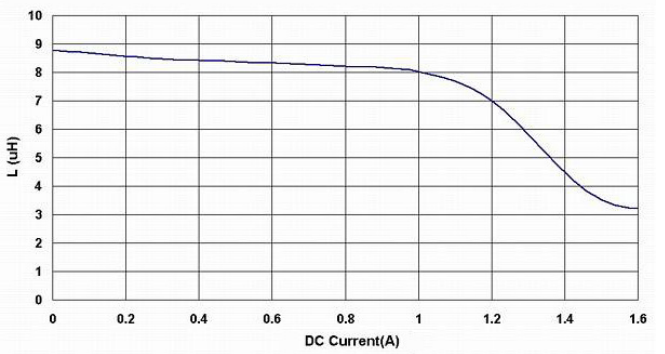

APSC00060620100□S0

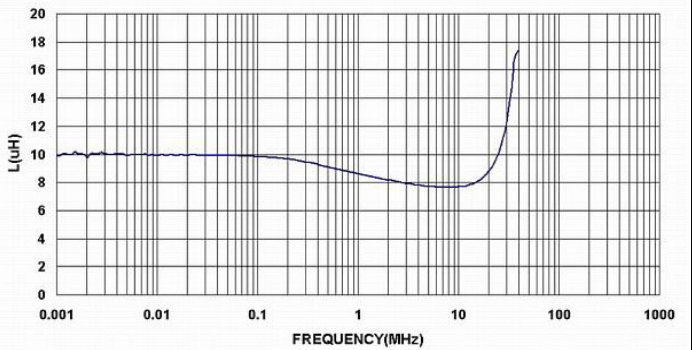
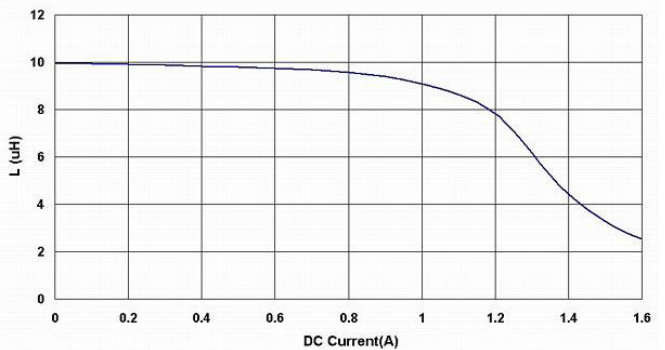

13 Graph:

APSC00060620120□S0

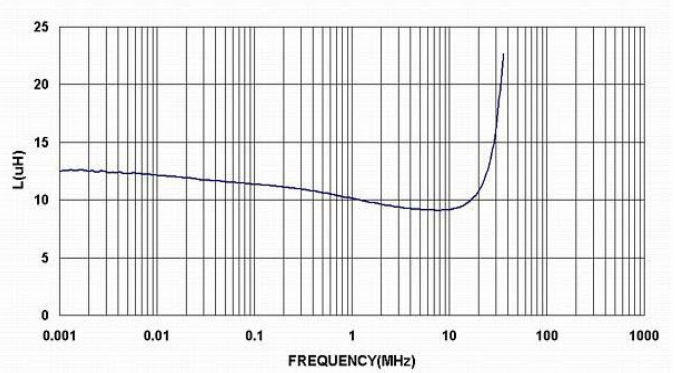
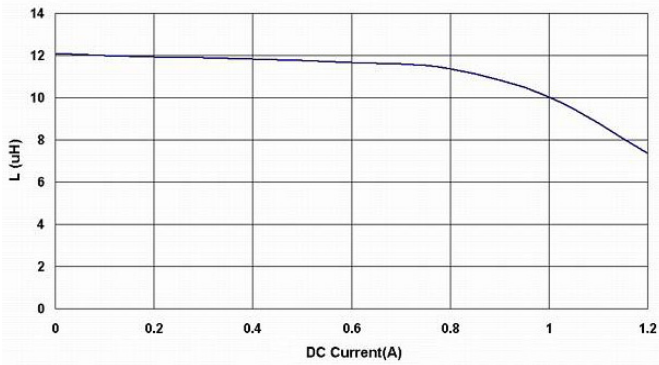

APSC00060620150□S0

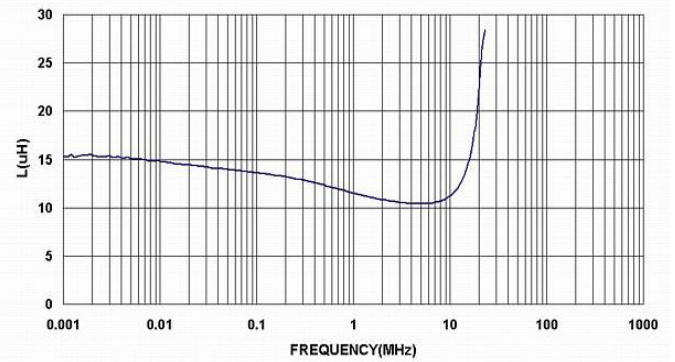
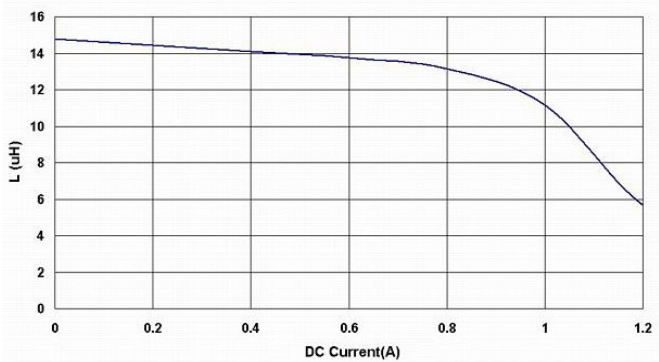

APSC00060620180□S0

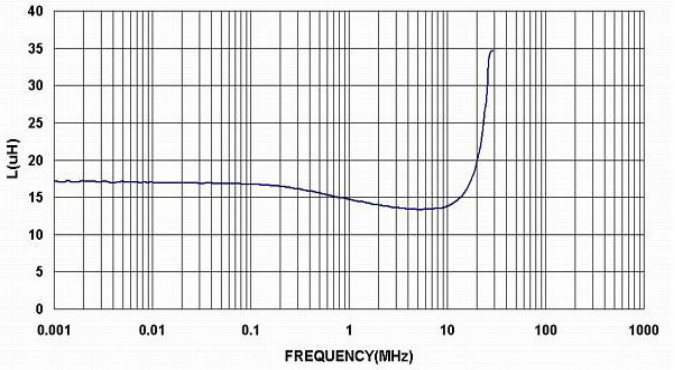
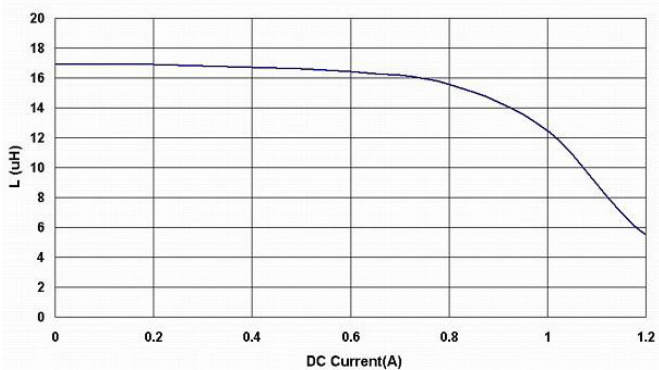

APSC00060620220□S0

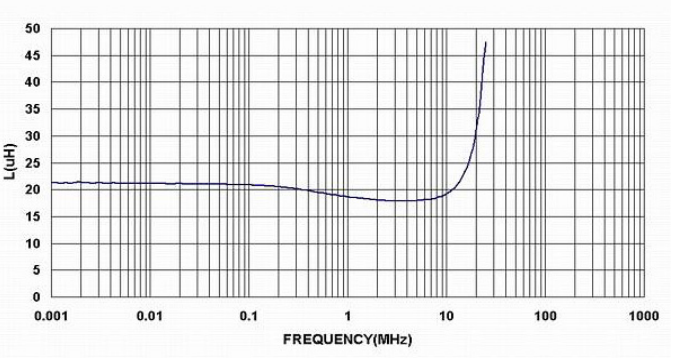
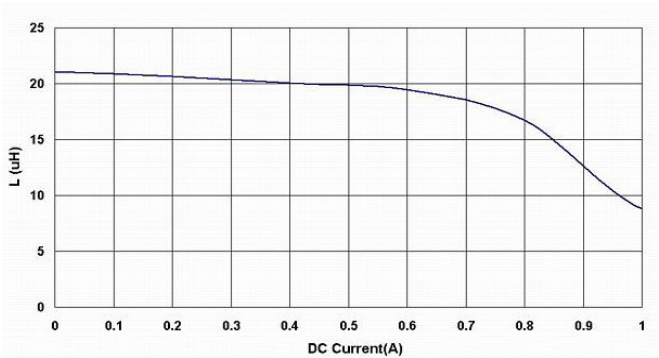

13 Graph:

APSC00060620270□S0

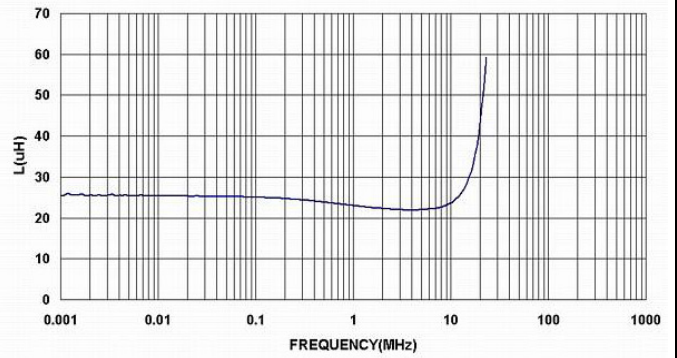
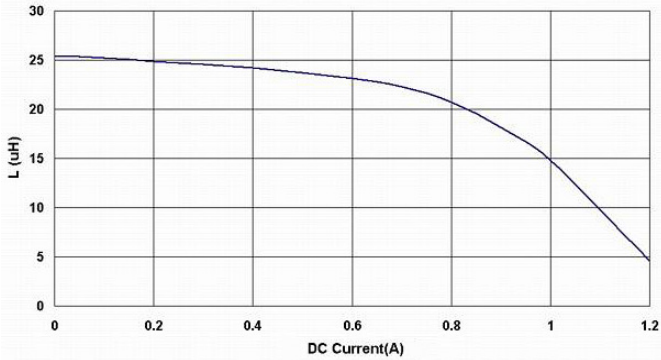

APSC00060620330□S0

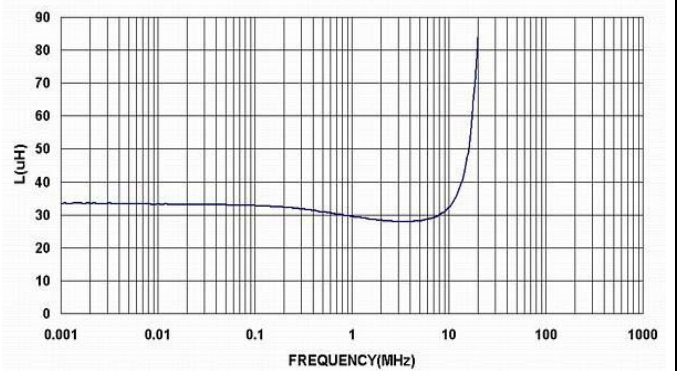
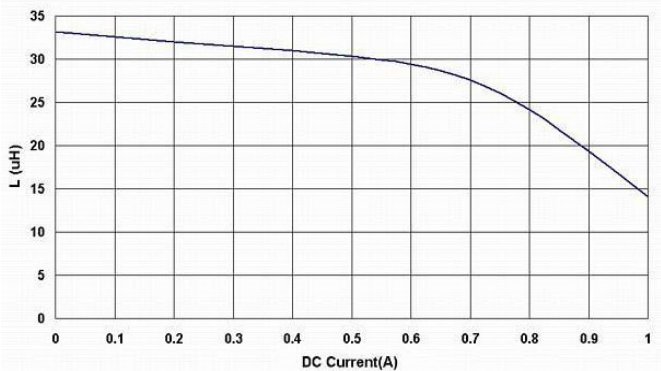

APSC00060620390□S0

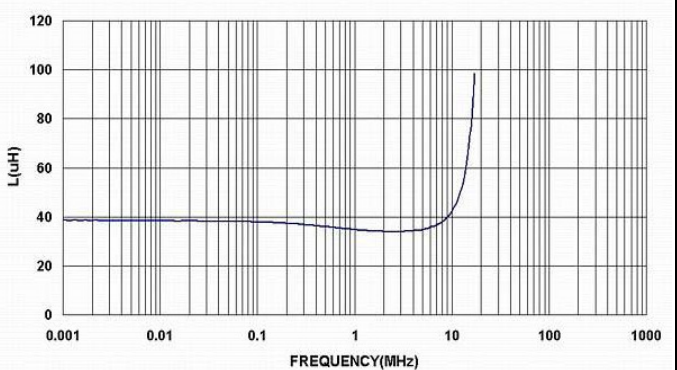
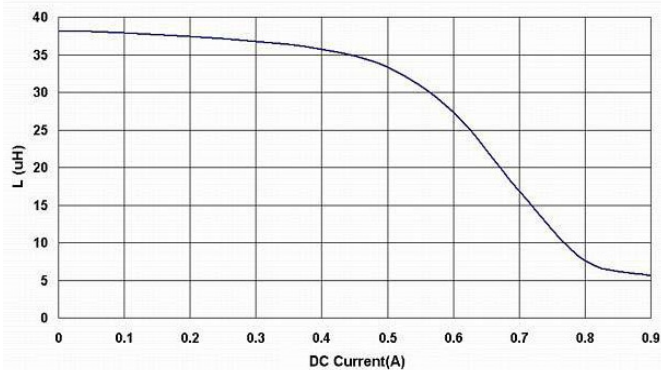

APSC00060620470□S0

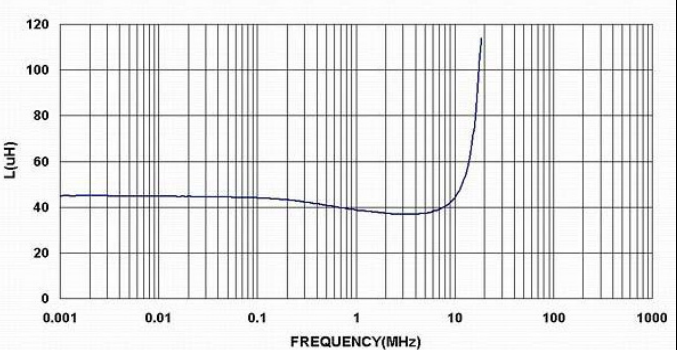
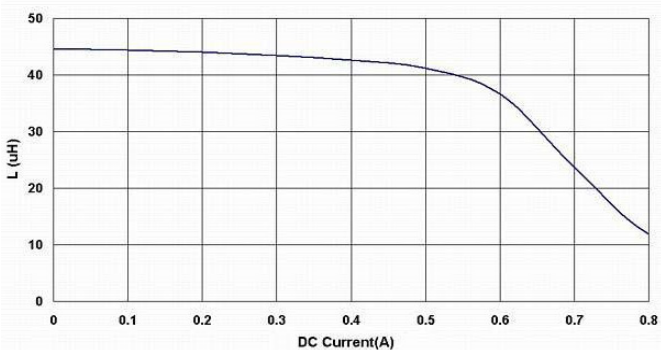

13 Graph:

APSC00060620560□S0

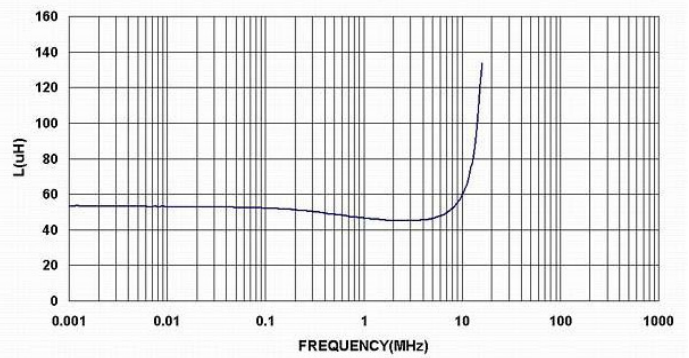
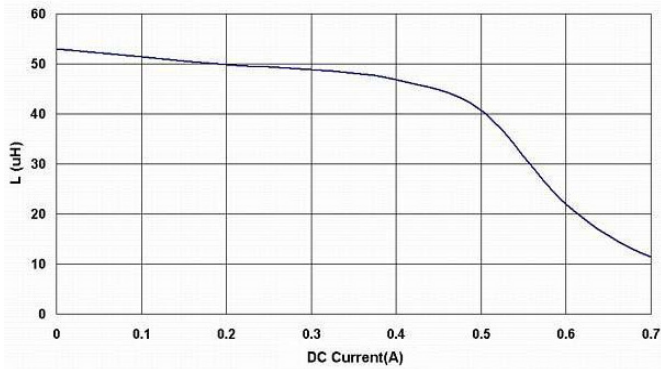

APSC00060620680□S0

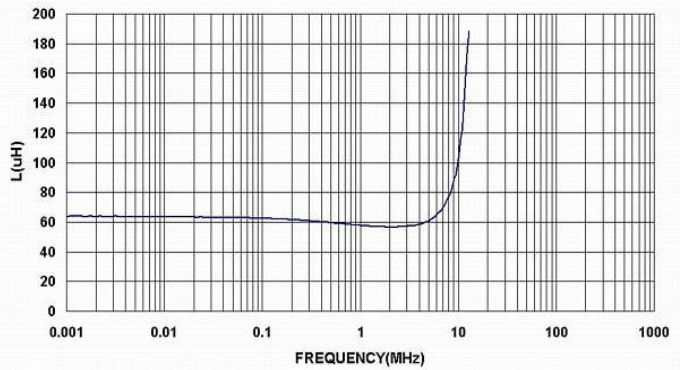
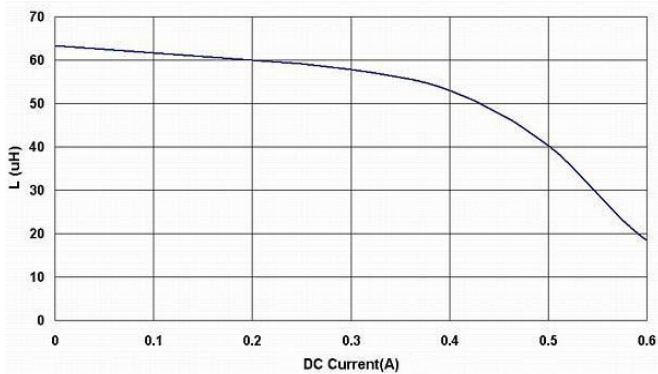

APSC00060620820□S0

