

Power Inductor

Automotive Grade

APSD Series



Overview

Power inductors are passive electronic components used in various circuits to store energy in a magnetic field when electrical current flows through them. They are critical in filtering, energy storage, and noise suppression in power electronic systems.

They are designed to handle higher currents and are optimized for minimal power loss and thermal efficiency.

Benefits

1. Automotive grade available
2. Plated terminals on the ferrite core, sample structure
3. Simple structure.
4. Operating temperature range $-40^{\circ}\text{C} \sim 150^{\circ}\text{C}$ (Including self - temperature rise)

Applications

1. Automotive Systems for CCD Module
2. Lighting, LCD Panel/TV
3. Net working
4. Home device

Product Information

Series	L (mm)	W (mm)	T (mm)	Inductance (μH)
APSD	3.3	3.0	2.1	0.15 ~ 1000
	4.5	4.0	3.2	
	5.8	5.2	3.0	
	5.8	5.2	4.5	
	7.8	7.0	3.5	
	7.8	7.0	5.0	



1 Scope: This specification applies to SMD Unshielded Power Inductors

2 Part Numbering:

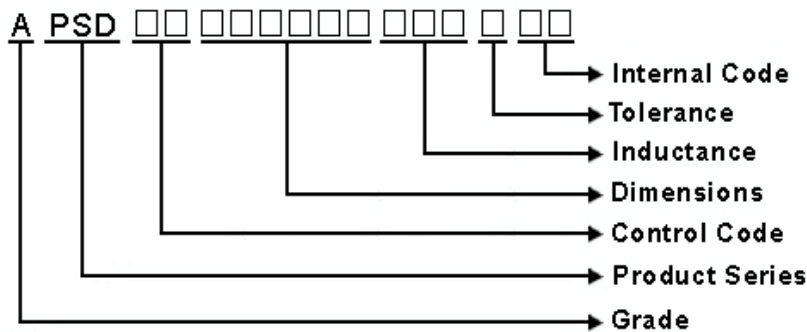

3 Rating:

Operating Temperature: - 40°C ~ + 125°C (Including self temp. rise)

Storage Temperature: - 40°C ~ + 125°C(For after the circuit board is mounted)

Storage Temperature: (on tape & reel): -20°C to +40°C; 75% RH max.

4 Marking:

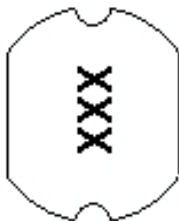

Ex Marking : 100

Marking color : Black

5 Standard Testing Condition

	Unless otherwise specified	In case of doubt
Temperature	Ordinary Temperature(15 to 35°C)	20 to 30°C
Humidity	Ordinary Humidity(25 to 85% RH)	50 to 80 %RH

APSD00060530 Series Specification

AEC-Q200

6 Configuration and Dimensions:

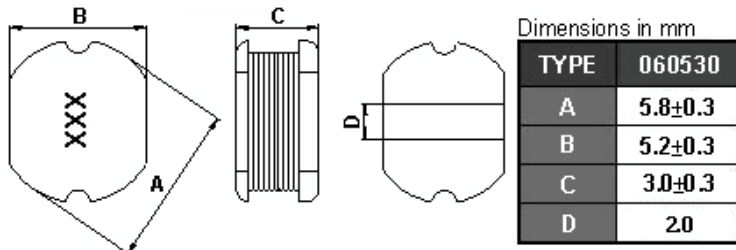

Net Weight (grms)

SIZE CODE	Net Weight (grms)
060530	0.31(Typ.)

7 Electrical Characteristics:

Part No.	Inductance (uH)	Test Freq.	RDC (Ω)Max.	Isat (A)	Irms (A)	Tolerance (±%)	Marking
APSD000605301R0□00	1	7.96 MHz,1 V	0.03	4.5	4.5	20	1R0
APSD000605301R2□00	1.2	7.96 MHz,1 V	0.03	4.2	4.2	20	1R2
APSD000605301R5□00	1.5	7.96 MHz,1 V	0.03	4.1	4.1	20	1R5
APSD000605301R8□00	1.8	7.96 MHz,1 V	0.03	3.7	3.7	10,20	1R8
APSD000605302R0□00	2	7.96 MHz,1 V	0.03	3.6	3.6	20	2R0
APSD000605302R2□00	2.2	7.96 MHz,1 V	0.03	3.5	3.5	20	2R2
APSD000605302R7□00	2.7	7.96 MHz,1 V	0.04	3.2	3.2	20	2R7
APSD000605303R3□00	3.3	7.96 MHz,1 V	0.05	2.8	2.8	10,20	3R3
APSD000605303R9□00	3.9	7.96 MHz,1 V	0.06	2.6	2.6	20	3R9
APSD000605304R7□00	4.7	7.96 MHz,1 V	0.07	2.5	2.5	10,20	4R7
APSD000605305R6□00	5.6	7.96 MHz,1 V	0.08	2.4	2.4	20	5R6
APSD000605306R8□00	6.8	7.96 MHz,1 V	0.09	2.2	2.2	20	6R8
APSD000605308R2□00	8.2	7.96 MHz,1 V	0.1	2	2	20	8R2
APSD00060530100□00	10	2.52 MHz,1 V	0.12	1.8	1.8	10,20	100
APSD00060530120□00	12	2.52 MHz,1 V	0.13	1.75	1.75	20	120
APSD00060530150□00	15	2.52 MHz,1 V	0.15	1.7	1.7	10,20	150
APSD00060530180□00	18	2.52 MHz,1 V	0.22	1.6	1.6	10,20	180
APSD00060530220□00	22	2.52 MHz,1 V	0.22	1.5	1.5	10,20	220
APSD00060530270□00	27	2.52 MHz,1 V	0.26	1.4	1.4	20	270
APSD00060530330□00	33	2.52 MHz,1 V	0.33	1.1	1.1	10,20	330
APSD00060530390□00	39	2.52 MHz,1 V	0.42	1	1	10,20	390
APSD00060530470□00	47	2.52 MHz,1 V	0.5	0.9	0.9	10,20	470
APSD00060530560□00	56	2.52 MHz,1 V	0.55	0.85	0.85	10,20	560
APSD00060530680□00	68	2.52 MHz,1 V	0.65	0.8	0.8	10,20	680
APSD00060530820□00	82	2.52 MHz,1 V	0.8	0.65	0.65	10,20	820

NOTE: □-tolerance K=±10% / M=±20%

1. Operating temperature range - 40 °C ~ 125 °C (Including self - temperature rise)
2. Isat for Inductance drop 10% from its value without current.
3. I rms for a 40 °C temperature rise from 25 °C ambient.
4. The actual use current is suggested not to be out of Isat*80%

APSD00060530 Series Specification

AEC-Q200

Part No.	Inductance (uH)	Test Freq.	RDC (Ω)Max.	Isat (A)	Irms (A)	Tolerance (\pm %)	Marking
APSD00060530101□00	100	1 kHz,1 V	0.9	0.6	0.6	10,20	101
APSD00060530121□00	120	1 kHz,1 V	1	0.58	0.58	10,20	121
APSD00060530151□00	150	1 kHz,1 V	1.3	0.43	0.43	10,20	151
APSD00060530181□00	180	1 kHz,1 V	1.5	0.41	0.41	10,20	181
APSD00060530221□00	220	1 kHz,1 V	2	0.38	0.38	10,20	221
APSD00060530271□00	270	1 kHz,1 V	2.5	0.35	0.35	10,20	271
APSD00060530331□00	330	1 kHz,1 V	3.2	0.28	0.28	10,20	331
APSD00060530391□00	390	1 kHz,1 V	3.5	0.26	0.26	10,20	391
APSD00060530471□00	470	1 kHz,1 V	4.2	0.2	0.2	10,20	471

8 APSD00060530 Series

8.1 Construction:

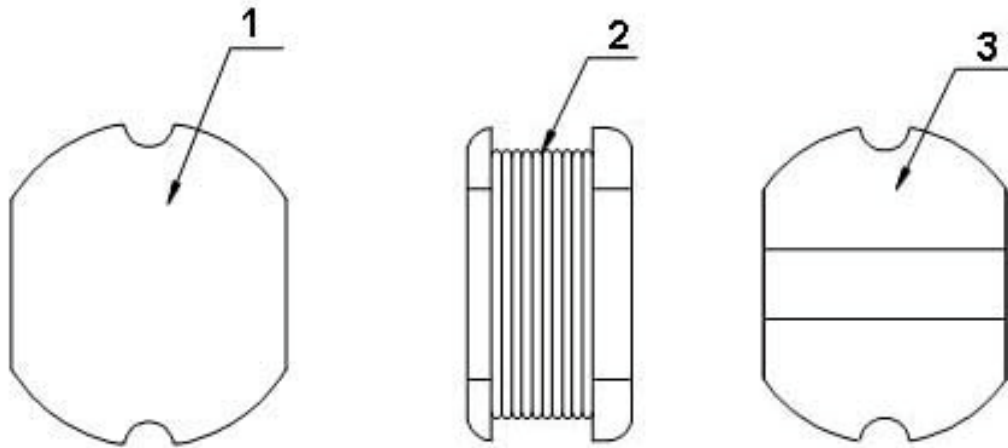

8.2 Material List:

No	Part	Material
1	Core	Ferrite
2	Wire	Magnet Wire
3	Terminal	Sn/Ag3.0/Cu0.5

9 Reliability Of Ferrite Wire Wound Power Inductor

1-1.Mechanical Performance

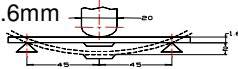
No	Item	Specification	Test Method
1-1-1	Board Flex	The forces applied on the right conditions must not damage the terminal electrode and the ferrite	Refer to AEC-Q200-005 Test device shall be soldered on the substrate Substrate Dimension: 100x40x1.6mm Deflection: 2.0mm Keeping Time: 60sec 
1-1-2	Resistance to Soldering Heat	Appearance: No damage Inductance change shall be within $\pm 10\%$.	Refer to MIL-STD-202 Method 210 Pre-heating: 150°C, 1min Solder Composition: Sn/Ag3.0/Cu0.5(Pb-Free) Solder Temperature: 250 \pm 5°C Immersion Time: 10 \pm 1sec
1-1-3	Solder ability	The electrodes shall be at least 95% covered with new solder coating	Refer to J-STD-002 Pre-heating: 150°C, 1min Solder Composition: Sn/Ag3.0/Cu0.5(Pb-Free) Solder Temperature: 245 \pm 5°C (Pb-Free) Immersion Time: 4 \pm 1sec
1-1-4	Terminal Strength Test	Appearance: No damage	Refer AEC-Q200-006 Soldered on PCB for testing as fig. Force : 1.8kg Keeping Time: 60 seconds.
1-1-5	Resistance to Solvent	There must be no change in appearance or obliteration of marking	Refer to MIL-STD-202 Method 215 Inductors must withstand 6 minutes of alcohol or water Sample Size : 15 pcs
1-1-6	Vibration	Appearance: No damage Inductance change shall be within $\pm 10\%$.	Refer MIL-STD-202 Method 204 Vibration waveform: Sine waveform Vibration frequency: 10Hz~2000Hz Vibration acceleration: 5g Sweep rate: 0.764386octave/minute Duration of test: 12 cycles each of 3 orientations, 20 minutes for each cycle Vibration axes: X, Y & Z

1-2.Environmental Performance

No	Item	Specification	Test Method
1-2-1	Temperature Cycle	Appearance: No damage Inductance change shall be within $\pm 30\%$	Refer to JESD Method JA-104 Total cycles: 1000 cycles Temperature Cycling Test Conditions : -40 to +125 °C -40 °C Soak Mode Condition : 30 minutes 125 °C Soak Mode Condition : 30 minutes Measured after exposure in the room condition for 24hrs
1-2-2	Biased Humidity Resistance		Refer to MIL-STD-202 Method 103 Temperature: 85 \pm 2°C Relative Humidity:85% / Time: 1000hrs Measured after exposure in the room condition for 24hrs
1-2-3	High Temperature Exposure (Storage)		Refer to MIL-STD-202 Method 108 Temperature: 125 \pm 3°C Time: 1000hrs Measured after exposure in the room condition for 24hrs
1-2-4	Operational Life		Refer to MIL-STD-202 Method 108 Temperature: 125 \pm 3°C Applied Current : Rated Current Time: 1000hrs Measured after exposure in the room condition for 24hrs

Reflow Soldering Profile

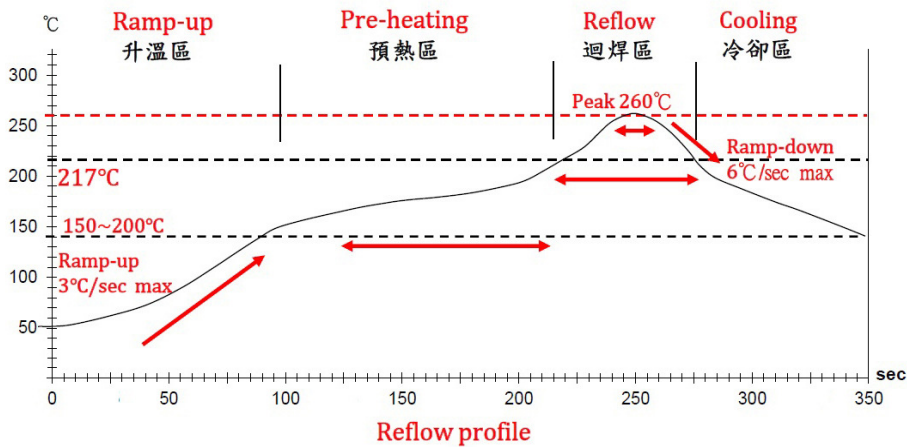

Lead-Free(LF)標準溫度分析範圍

Refer to J-STD-020C

管制項目 Item.	升温區 Ramp-up	预热區 Pre-heating	迴焊區 Reflow	Peak Temp	冷卻區 Cooling
溫度範圍 Temp.scope	R.T ~ 150°C	150°C ~ 200°C	217°C	260±5°C	Peak Temp.~150°C
標準時間 Time spec.	-	60 ~ 180 sec	60 ~ 150 sec	20 ~ 40 sec	-
實際時間 Time result	-	75 ~ 100 sec	90 ~ 120 sec	20 ~ 35 sec	-

10 Packaging:

10.1 Packaging -Cover Tape

The force for tearing off cover tape is 10 to 130 grams in the arrow direction.

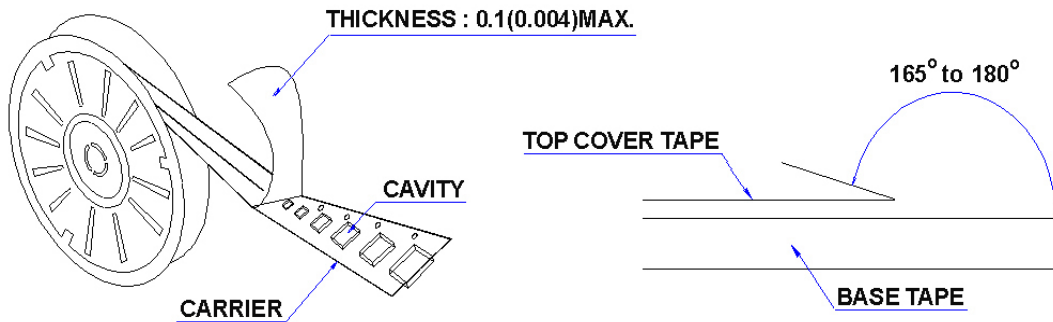

10.2 Packaging Quantity

TYPE	PCS/REEL
060530	2000

10.3 Reel Dimensions

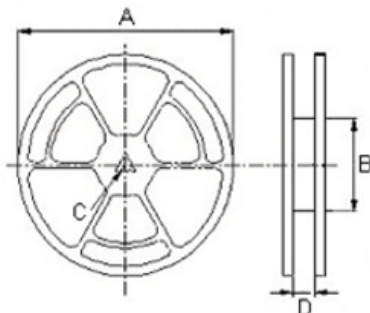

Dimensions in mm

TYPE	A	B	C	D
060530	330	100	13	16

10 Packaging:

10.4 Tape Dimensions in mm

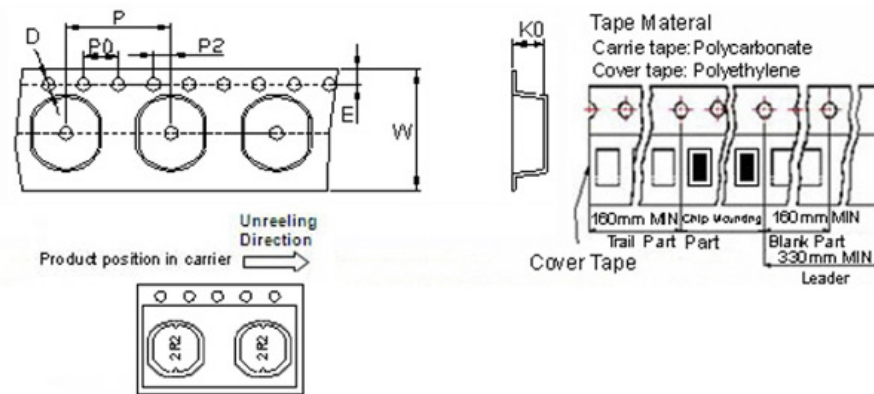

TYPE	K0	D	E	W	P	P0	P2
060530	3.30	1.5	1.75	16	8	4	2

11 Recommended Land Pattern:

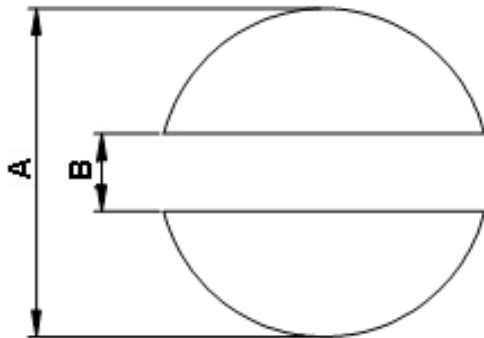

Dimensions in mm

TYPE	A	B
060530	6.8	2.0

12 Note:

1. Please make sure that your product has been evaluated and confirmed against your specifications when our product is mounted to your product.
2. Do not knock nor drop.
3. All the items and parameters in this product specification have been prescribed on the premise that our product is used for the purpose, under the condition and in the environment agreed upon between you and us. You are requested not to use our product deviating from such agreement.
4. Please keep the distance between transformer/coil and other components (refer to the standard IEC 950)
5. The moisture sensitivity level (MSL) of products is classified as level 1.

13 Graph:

APSD000605301R0□00

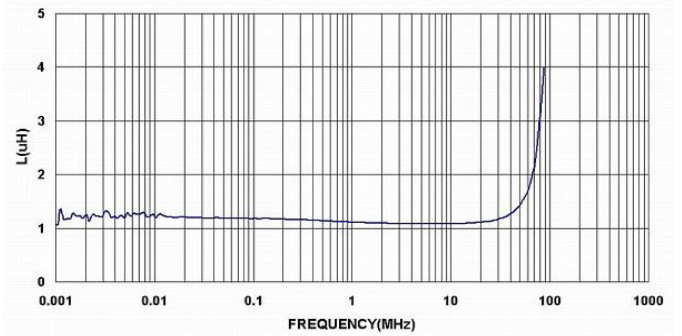
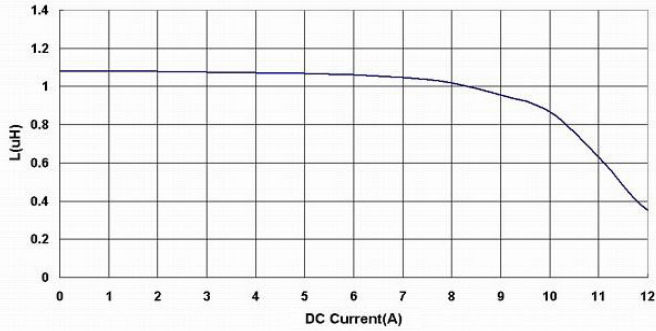

APSD000605301R2□00

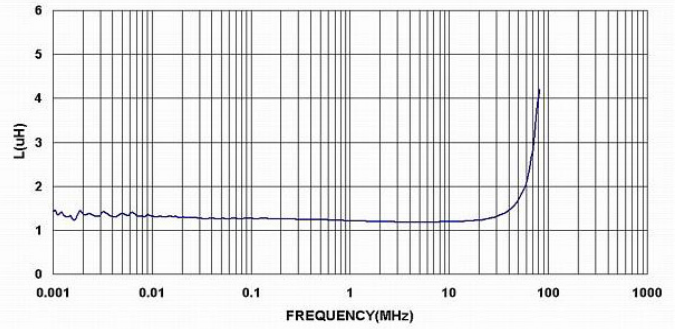
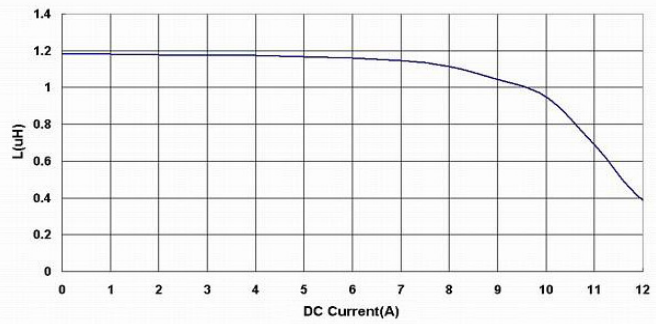

APSD000605301R5□00

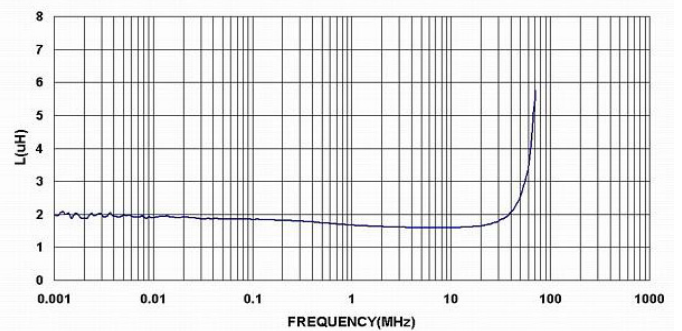
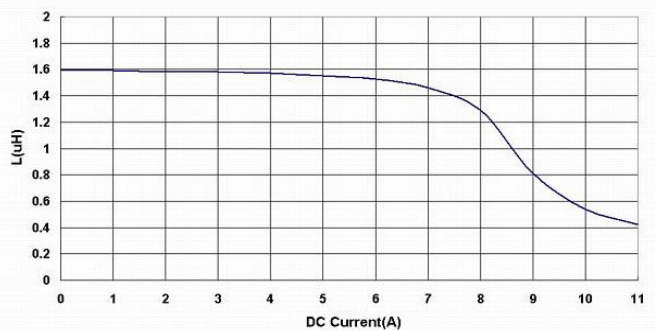

APSD000605301R8□00

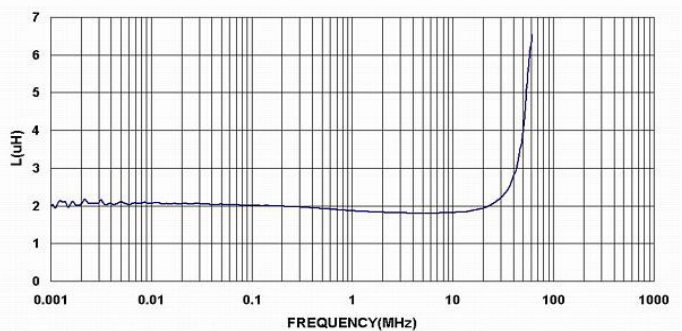
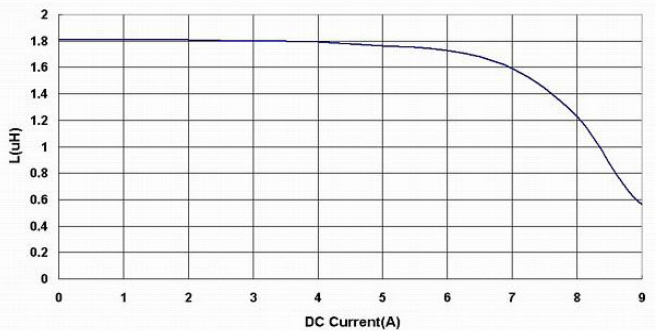

13 Graph:

APSD000605302R0□00

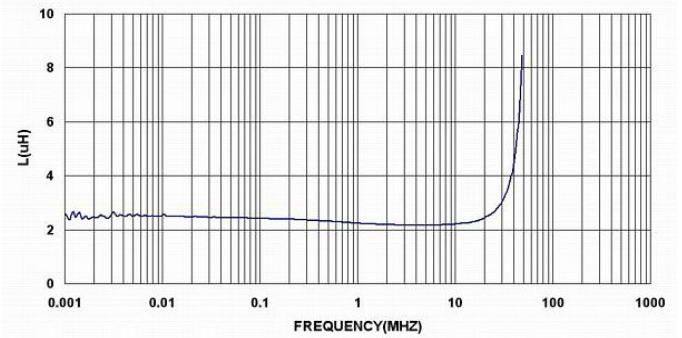
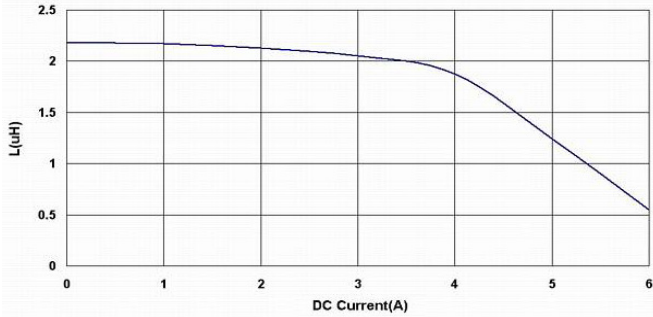

APSD000605302R2□00

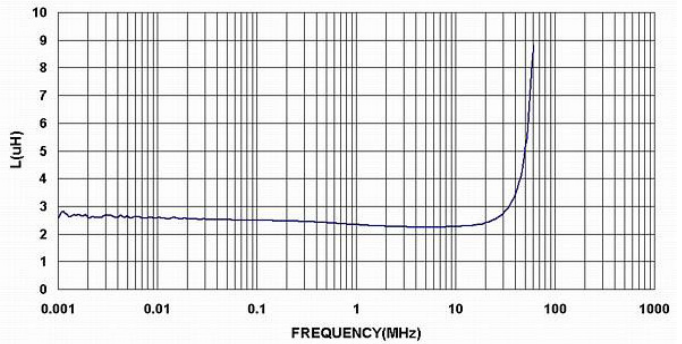
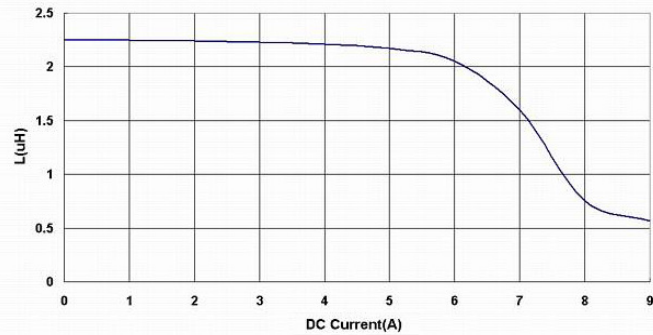

APSD000605302R7□00

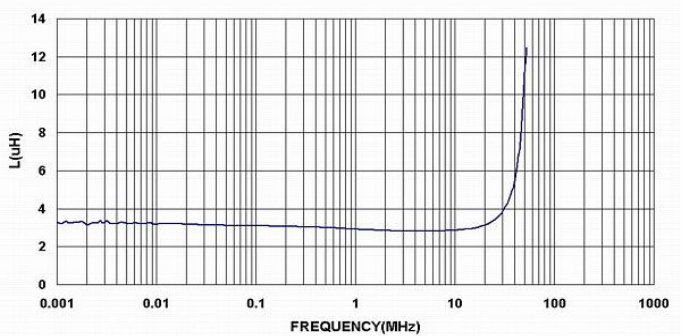
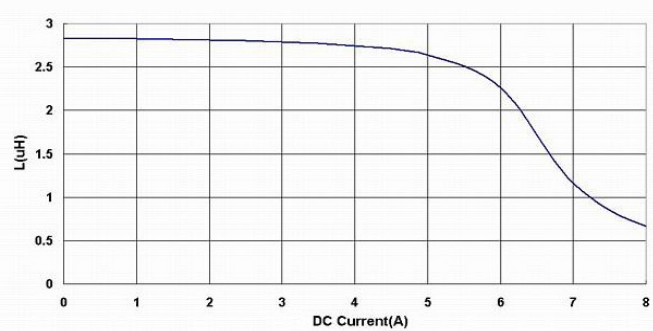

APSD000605303R3□00

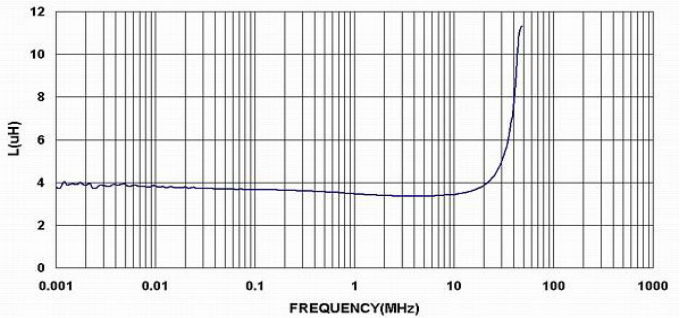
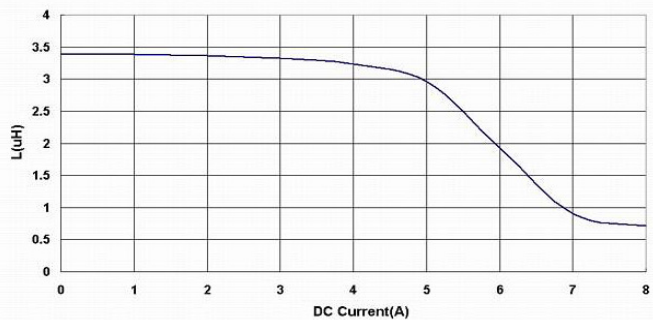

13 Graph:

APSD000605303R9□00

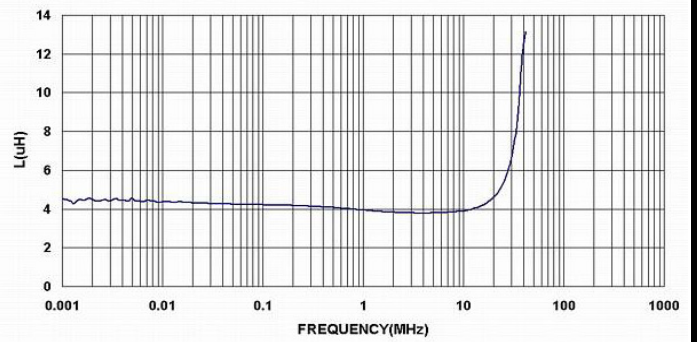

APSD000605304R7□00

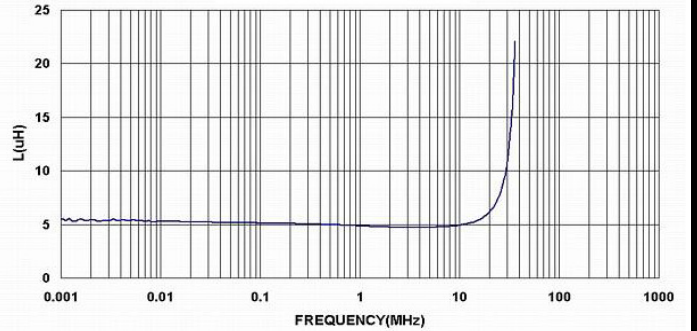

APSD000605305R6□00

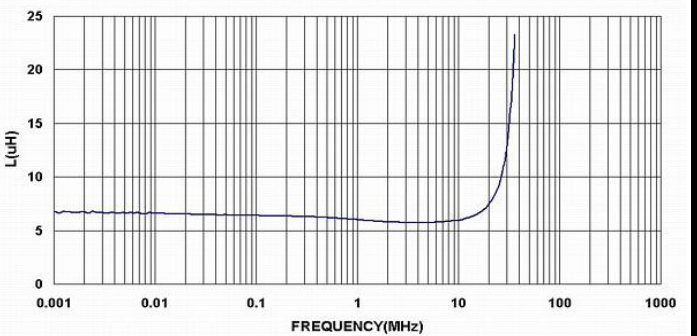
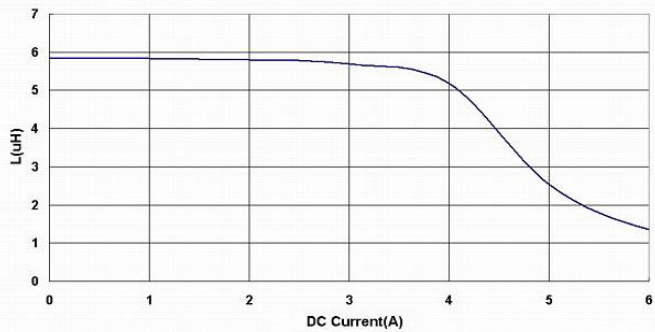

APSD000605306R8□00

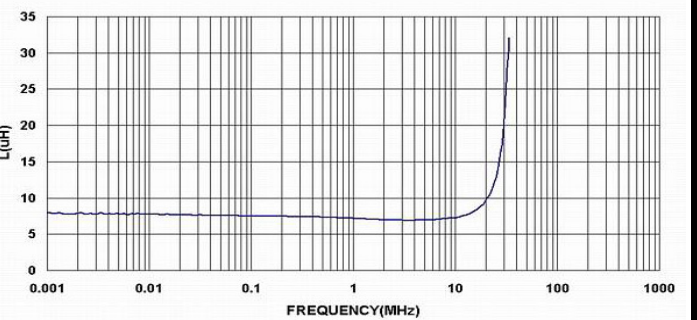
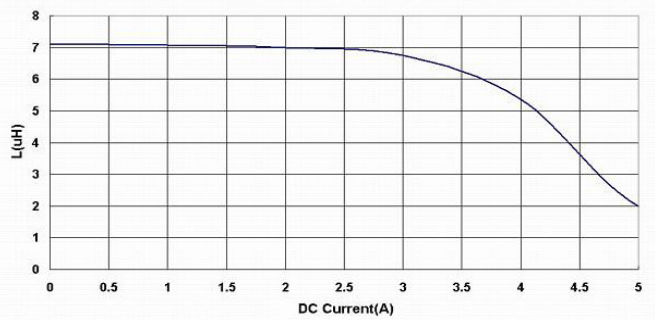

13 Graph:

APSD000605308R2□00

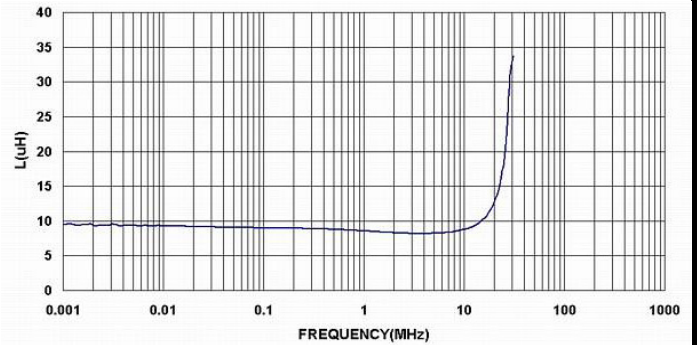
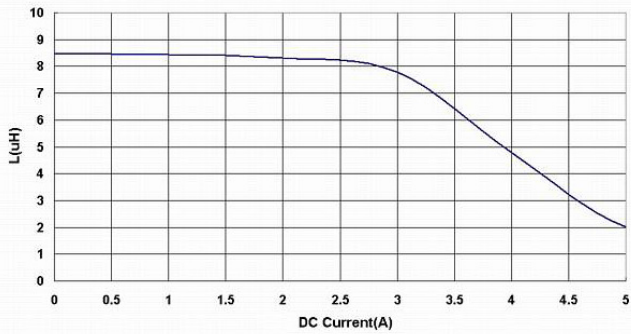

APSD00060530100□00

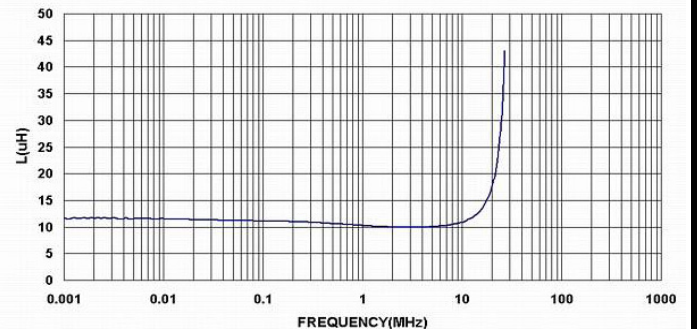
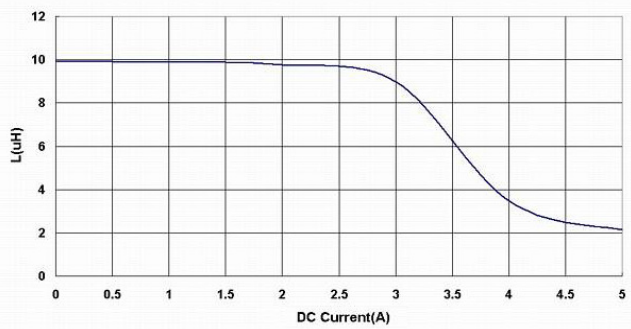

APSD00060530120□00

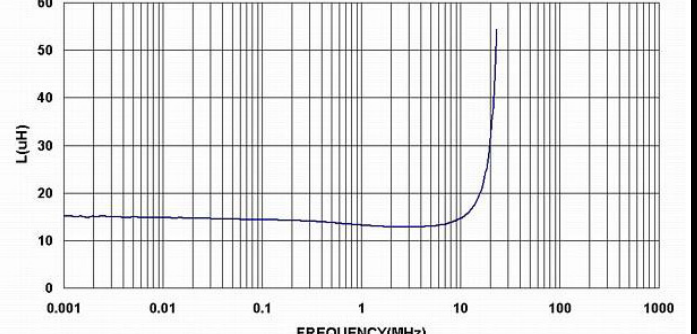
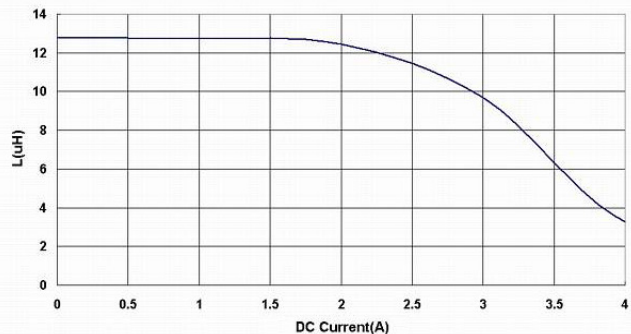

APSD00060530150□00

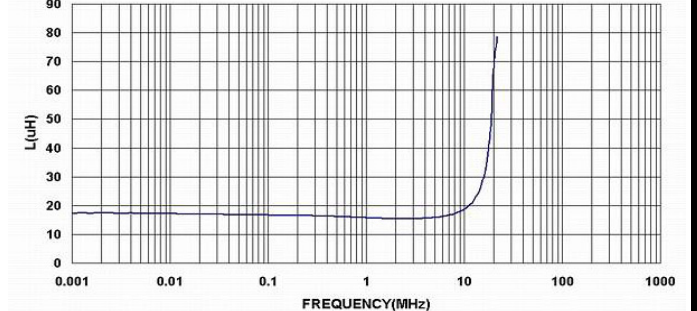
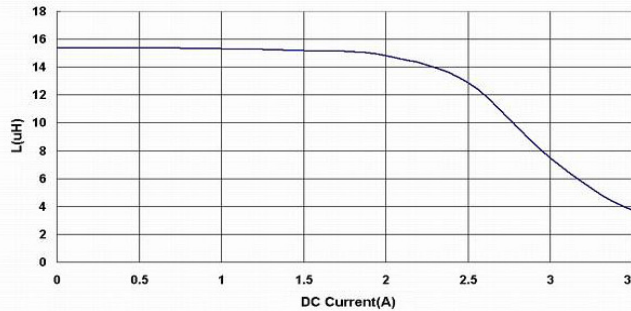

13 Graph:

APSD00060530180□00

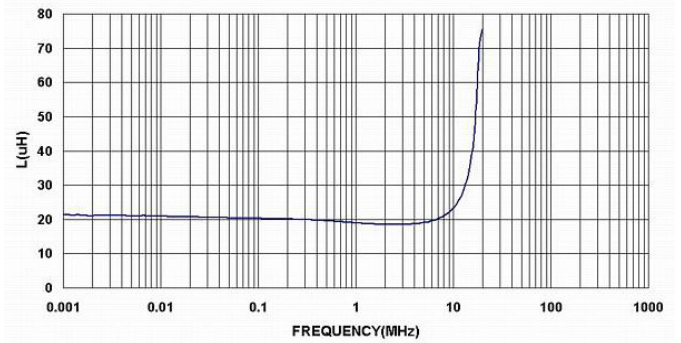
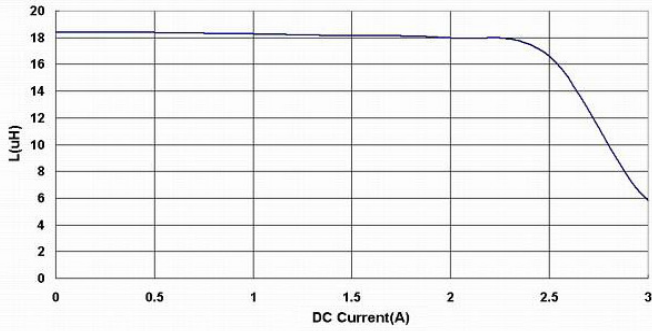

APSD00060530220□00

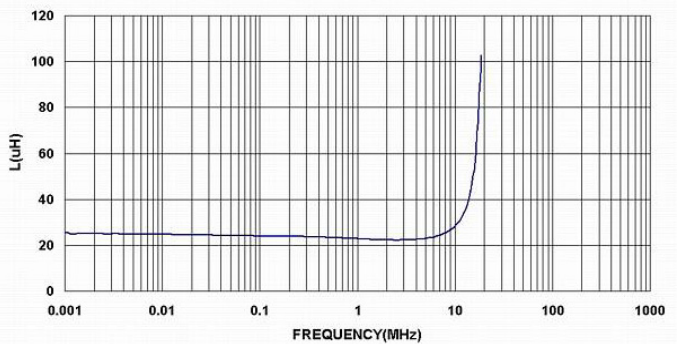
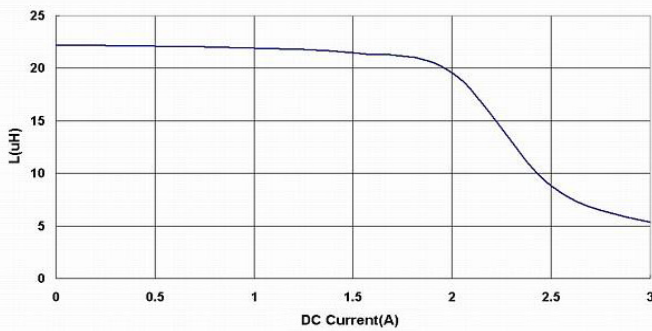

APSD00060530270□00

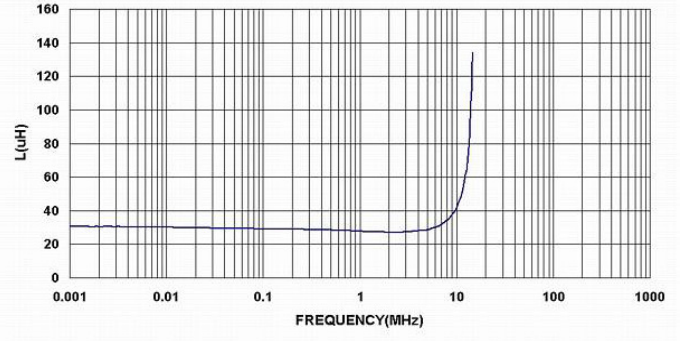
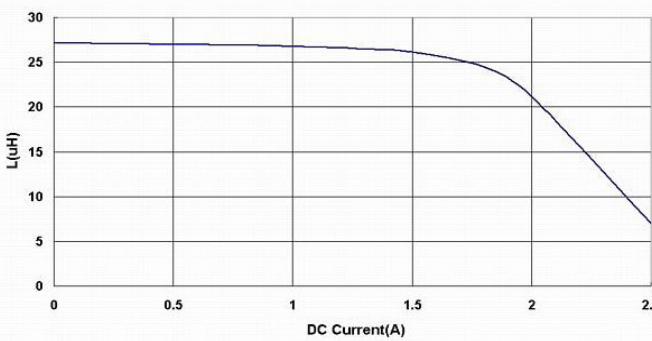

APSD00060530330□00

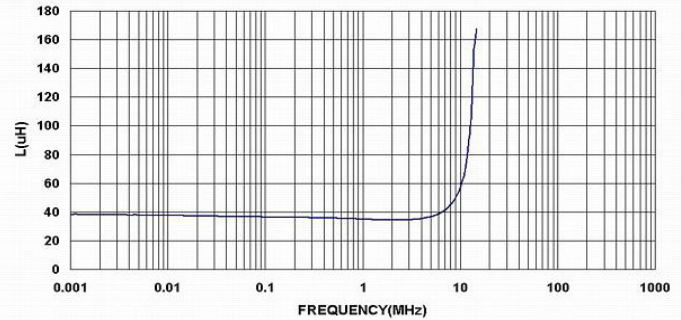
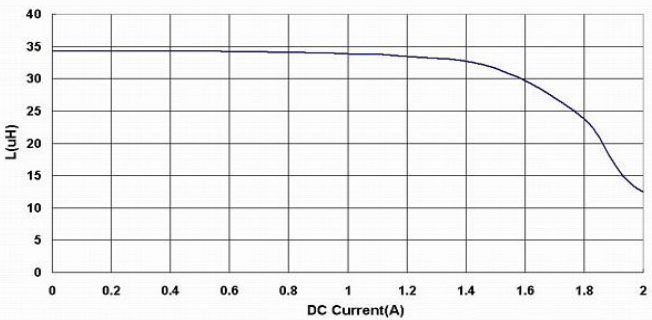

13 Graph:

APSD00060530390□00

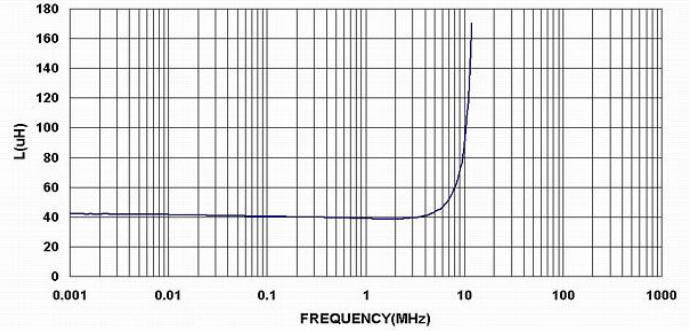
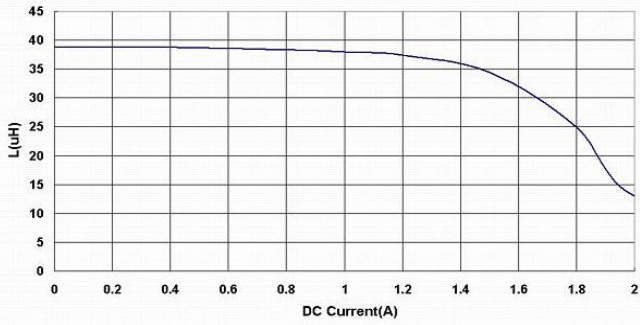

APSD00060530470□00

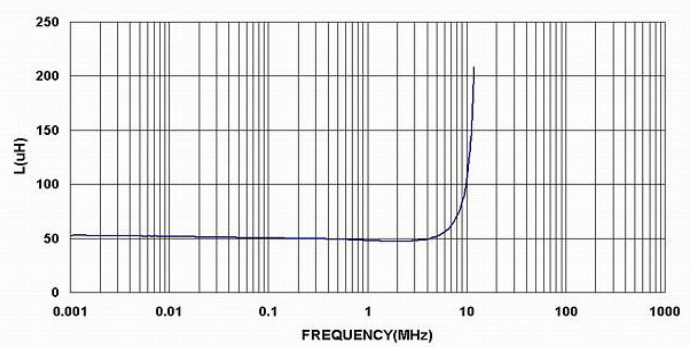
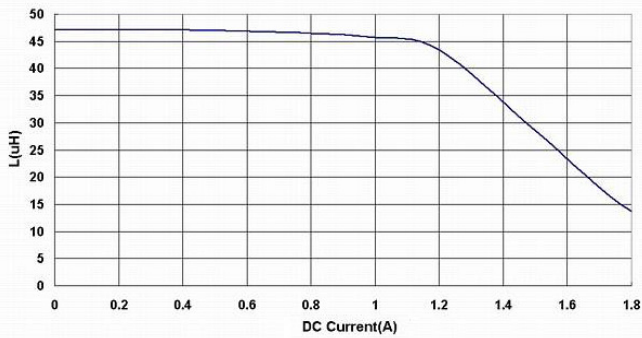

APSD00060530560□00

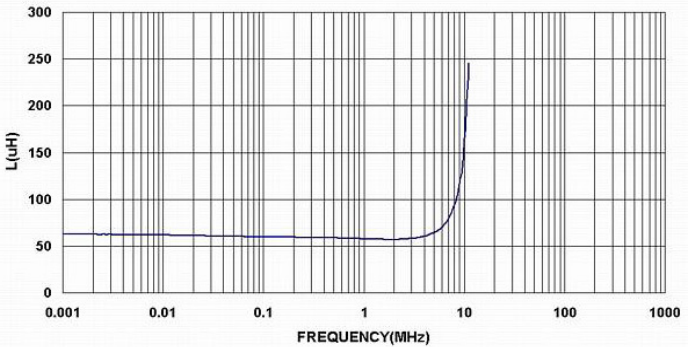
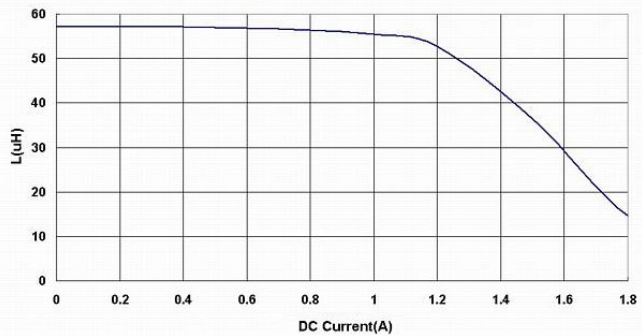

APSD00060530680□00

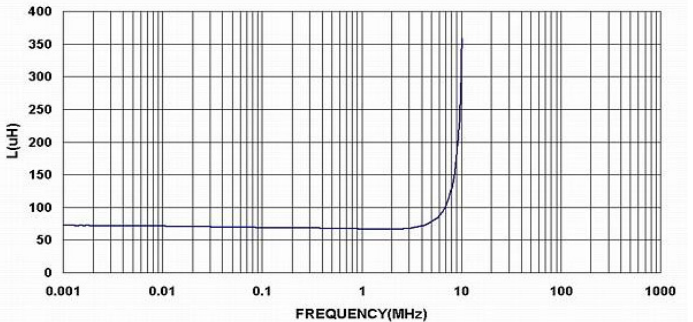
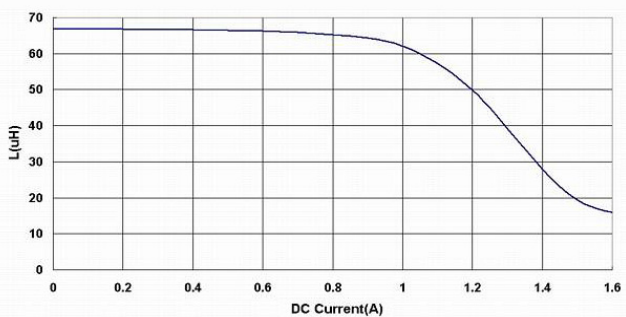

13 Graph:

APSD00060530820□00

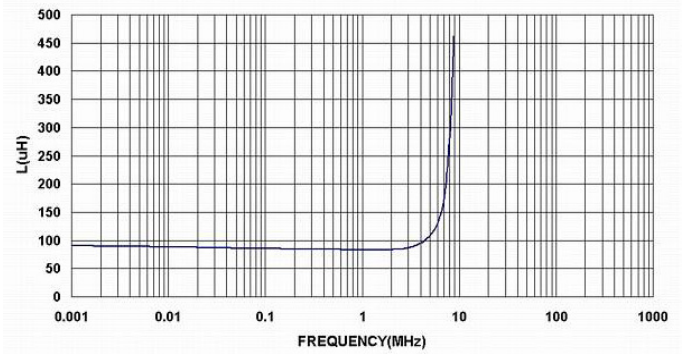
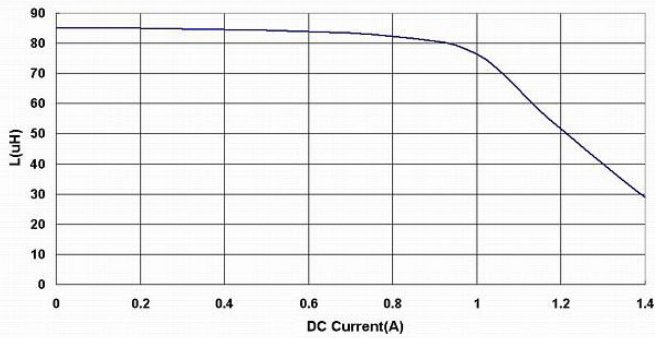

APSD00060530101□00

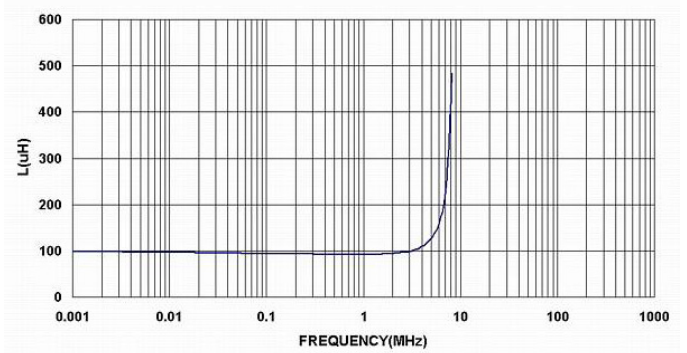
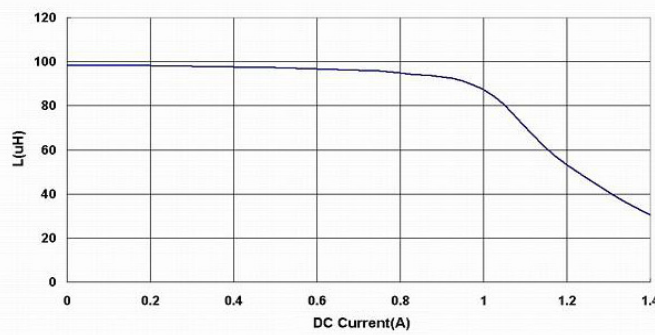

APSD00060530121□00

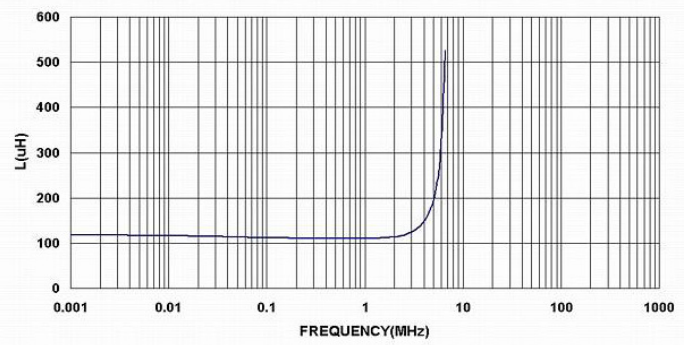
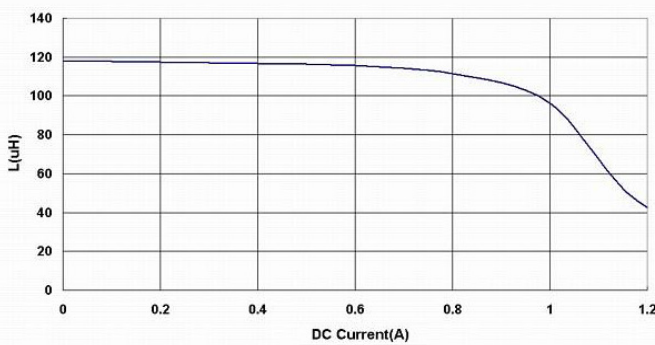

APSD00060530151□00

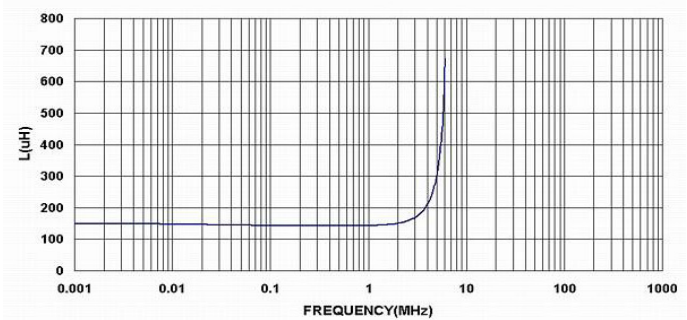
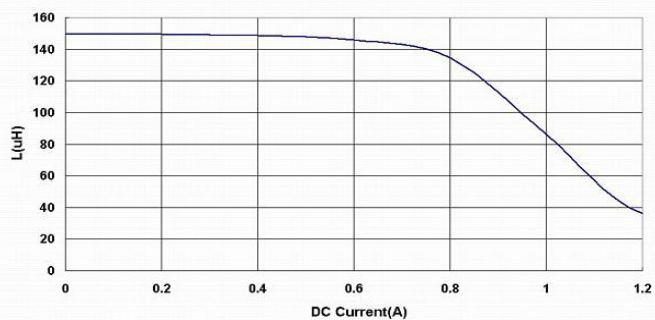

13 Graph:

APSD00060530181□00

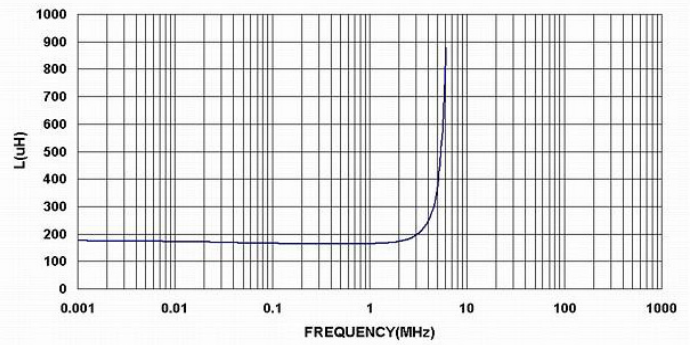
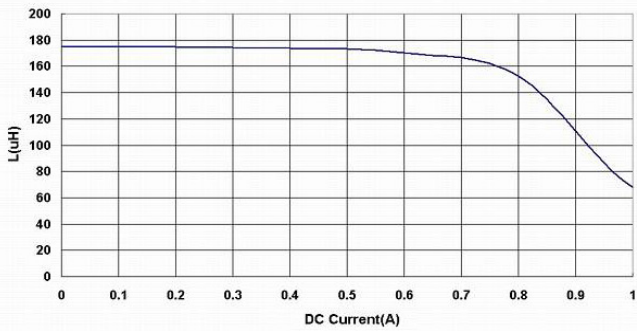

APSD00060530221□00

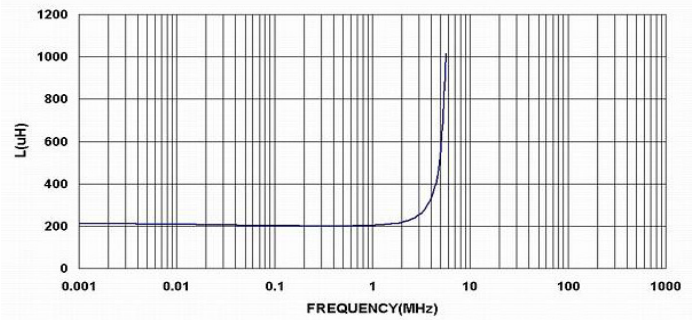
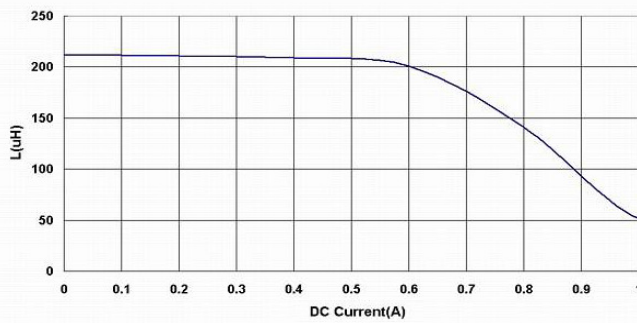

APSD00060530271□00

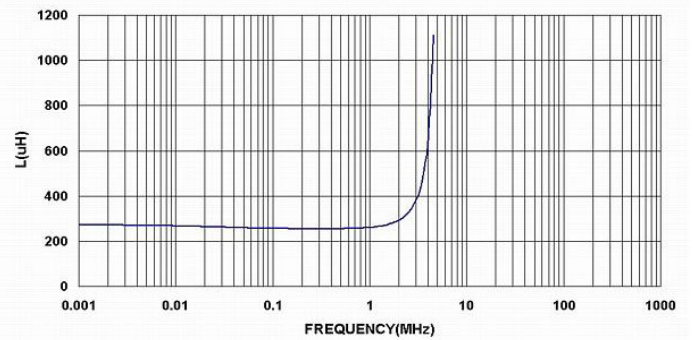
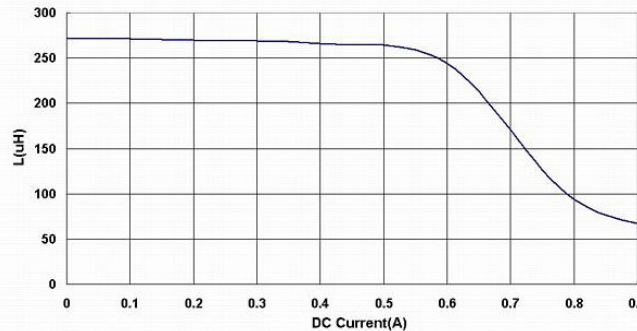

APSD00060530331□00

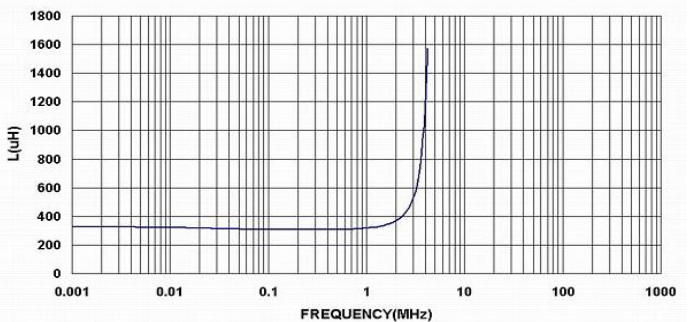
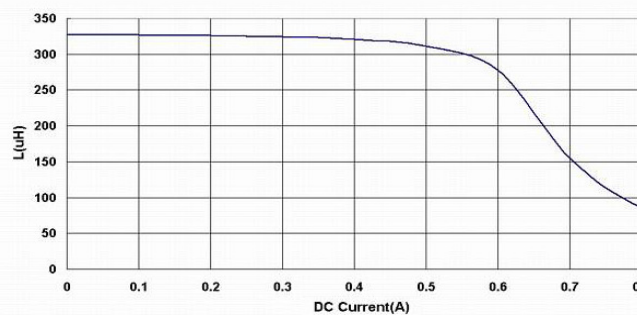

13 Graph:

APSD00060530391□00

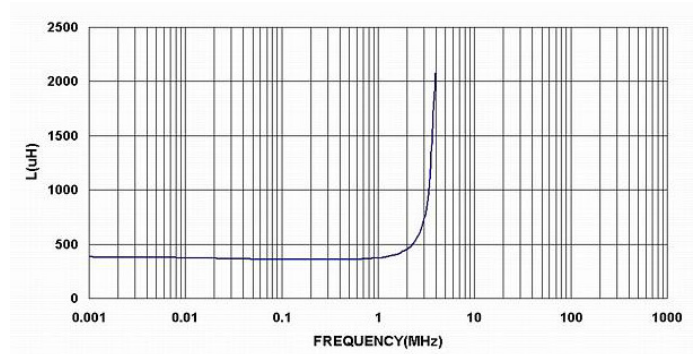
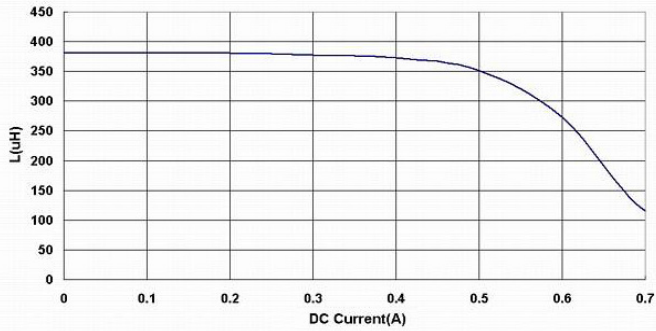

APSD00060530471□00

