

# Power Inductor



## BPSC Series



### Overview

Power inductors are passive electronic components used in various circuits to store energy in a magnetic field when electrical current flows through them. They are critical in filtering, energy storage, and noise suppression in power electronic systems. They are designed to handle higher currents and are optimized for minimal power loss and thermal efficiency.

### Benefits

1. Ferrite SMD Shielded Type
2. No thermal aging

### Applications

1. AP Routers, STBs
2. LCD TVs and monitors
3. Game consoles
4. LED lightings
5. DC/DC converters

### Product Information

Series	L (mm)	W(mm)	T (mm)	Inductance (μH)
BPSC	3.2	3.2	1.55	0.47 ~ 3300
	3.2	3.2	2.0	
	4.0	4.0	1.2	
	4.0	4.0	1.8	
	4.0	4.0	3.0	
	4.7	4.7	2.0	
	4.7	4.7	3.0	
	4.7	4.7	4.0	
	5.7	5.7	2.0	
	5.7	5.7	3.0	
	6.7	6.7	3.0	
	7.3	7.3	3.4	
	7.0	7.0	4.0	
	7.3	7.3	4.5	
	8.3	8.3	4.5	
	10.3	10.5	3.1	
	10.3	10.5	4	
10.3	10.5	5.1		
12.5	12.5	4.5		
12.5	12.5	6		
12.5	12.5	8		
12.0	12.0	10.0		



## BPSC00050530 Series Specification

**1 Scope:** This specification applies to SMD Shielded Power Inductors

**2 Part Numbering:**

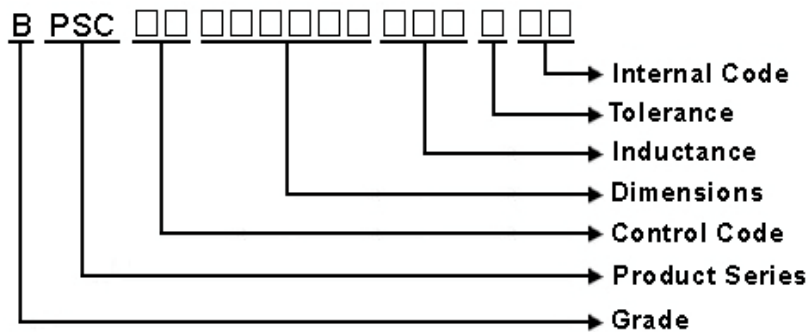

**3 Rating:**

Operating Temperature:  $-40^{\circ}\text{C} \sim +125^{\circ}\text{C}$  (Including self temp. rise)

Storage Temperature:  $-40^{\circ}\text{C} \sim +125^{\circ}\text{C}$  (For after the circuit board is mounted)

Storage Temperature: (on tape & reel):  $-20^{\circ}\text{C}$  to  $+40^{\circ}\text{C}$ ; 75% RH max.

**4 Marking:**

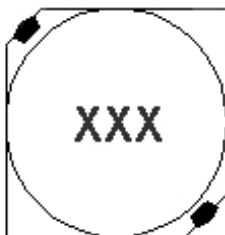

**Ex Marking : 3R3**

**Marking color : Black**

**5 Standard Testing Condition**

	Unless otherwise specified	In case of doubt
Temperature	Ordinary Temperature(15 to 35°C)	20 to 30°C
Humidity	Ordinary Humidity(25 to 85% RH)	50 to 80 %RH

## BPSC00050530 Series Specification

### 6 Configuration and Dimensions and Unit Weight:

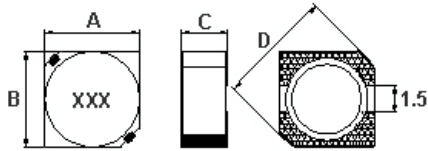

Dimensions in mm

TYPE	A	B	C	D
050530	4.7±0.3	4.7±0.3	3Max.	6.9Max.

### Net Weight (grms)

SIZE CODE	Net Weight (grms)
050530	0.35(Typ.)

### 7 Electrical Characteristics:

Part No.	Inductance (uH)	Test Freq.	RDC (Ω)Max.	Isat(A) Max(Typ)	Tolerance (±%)	Marking
BPSC000505301R2□S0	1.2	100 kHz,1 V	0.0236	2.56(4.10)	30	1R2
BPSC000505301R8□S0	1.8	100 kHz,1 V	0.035	2.20(3.20)	30	1R8
BPSC000505302R0□S0	2	100 kHz,1 V	0.03	2.10(3.00)	30	2R0
BPSC000505302R2□S0	2.2	100 kHz,1 V	0.0313	2.04(2.90)	20,30	2R2
BPSC000505302R7□S0	2.7	100 kHz,1 V	0.0433	1.60(2.80)	30	2R7
BPSC000505303R3□S0	3.3	100 kHz,1 V	0.0492	1.57(2.30)	30	3R3
BPSC000505303R9□S0	3.9	100 kHz,1 V	0.0648	1.44(2.10)	30	3R9
BPSC000505304R7□S0	4.7	100 kHz,1 V	0.072	1.32(2.00)	20,30	4R7
BPSC000505305R6□S0	5.6	100 kHz,1 V	0.1009	1.17(1.70)	30	5R6
BPSC000505306R8□S0	6.8	100 kHz,1 V	0.1089	1.12(1.60)	20,30	6R8
BPSC000505308R2□S0	8.2	100 kHz,1 V	0.1175	1.04(1.50)	30	8R2
BPSC00050530100□S0	10	100 kHz,1 V	0.1283	1.00(1.30)	20,30	100
BPSC00050530120□S0	12	100 kHz,1 V	0.1316	0.84(1.10)	30	120
BPSC00050530150□S0	15	100 kHz,1 V	0.149	0.76(1.00)	30	150
BPSC00050530180□S0	18	100 kHz,1 V	0.166	0.72(0.99)	30	180
BPSC00050530220□S0	22	100 kHz,1 V	0.235	0.70(0.93)	20,30	220
BPSC00050530270□S0	27	100 kHz,1 V	0.261	0.58(0.83)	30	270
BPSC00050530330□S0	33	100 kHz,1 V	0.3313	0.56(0.64)	20,30	330
BPSC00050530390□S0	39	100 kHz,1 V	0.3837	0.50(0.70)	20,30	390
BPSC00050530470□S0	47	100 kHz,1 V	0.587	0.48(0.61)	20,30	470
BPSC00050530560□S0	56	100 kHz,1 V	0.6245	0.41(0.54)	30	560
BPSC00050530680□S0	68	100 kHz,1 V	0.699	0.35(0.49)	30	680
BPSC00050530820□S0	82	100 kHz,1 V	0.9148	0.32(0.49)	30	820
BPSC00050530101□S0	100	100 kHz,1 V	1.02	0.29(0.45)	20,30	101
BPSC00050530121□S0	120	100 kHz,1 V	1.27	0.27(0.40)	30	121

**NOTE:** □-tolerance M=±20% / T=±30%

1. Operating temperature range - 3 0 °C ~ 1 0 0 °C(Including self - temperature rise)

2. Isat for Inductance drop 35% from its value without current.

3. RDC test method: place testing device to the 2 solder ends of winding and test the value.

## BPSC00050530 Series Specification

Part No.	Inductance ( $\mu\text{H}$ )	Test Freq.	RDC ( $\Omega$ )Max.	Isat(A) Max(Typ)	Tolerance ( $\pm\%$ )	Marking
BPSC00050530151□S0	150	100 kHz, 1 V	1.35	0.24(0.34)	30	151
BPSC00050530181□S0	180	100 kHz, 1 V	1.54	0.22(0.32)	30	181
BPSC00050530221□S0	220	100 kHz, 1 V	2	0.20(0.29)	30	221
BPSC00050530331□S0	330	100 kHz, 1 V	3.4	0.19(0.24)	20,30	331
BPSC00050530391□S0	390	100 kHz, 1 V	3.56	0.18(0.22)	20,30	391
BPSC00050530681□S0	680	100 kHz, 1 V	5.2	0.10(0.17)	20,30	681

## BPSC00050530 Series Specification

### 8 BPSC00050530 Series

#### 8.1 Construction:

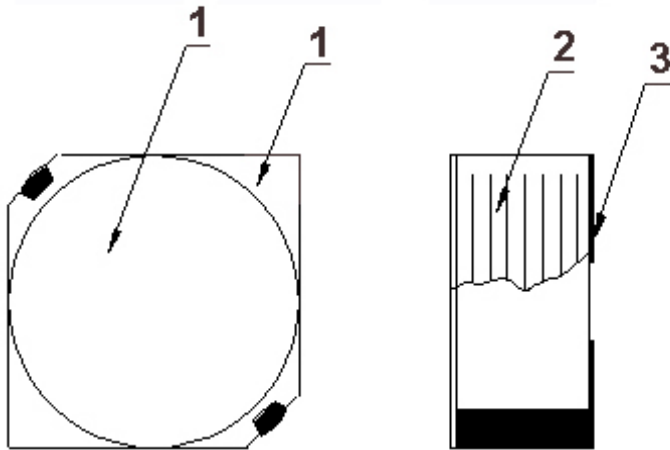

#### 8.2 Material List:

No	Part	Material
1	CORE	FERRITE
2	WIRE	MAGNET WIRE
3	TERMINAL	TERMINAL COPPER

## BPSC00050530 Series Specification

### 9 Reliability Of Ferrite Wire Wound Power Inductor

#### 1-1.Mechanical Performance

No	Item	Specification	Test Method
1-1-1	Vibration	Appearance: No damage L change: within±10%	Test device shall be soldered on the substrate Oscillation Frequency: 10 to 55 to 10Hz for 1min Amplitude: 1.5mm Time: 2hrs for each axis (X, Y & Z), total 6hrs
1-1-2	Resistance to Soldering Heat	Appearance: No damage	Pre-heating: 150℃, 1min Solder Composition: Sn/Ag3.0/Cu0.5 Solder Temperature: 260±5℃ Immersion Time: 10±1sec
1-1-3	Solderability	The electrodes shall be at least 95% covered with new solder coating	Pre-heating: 150℃, 1min Solder Composition: Sn/Ag3.0/Cu0.5 Solder Temperature: 245±5℃ Immersion Time: 4±1sec
1-1-4	Resistance to solvent	There must be no change in appearance or obliteration of marking.	Inductors must withstand 6 minutes of alcohol or water.

#### 1-2.Environmental Performance

No	Item	Specification	Test Method															
1-2-1	Temperature Shock	Appearance: No damage L change: within±10%	10 cycles (Air to Air) 1 cycles shall consist of: 30 minutes exposure to -55 ℃ 30 minutes exposure to 130 ℃ 15 seconds maximum transition between temperatures Measured after exposure in the room condition for 24hrs															
1-2-2	Temperature Cycle		One cycle: <table border="1"> <thead> <tr> <th>Step</th> <th>Temperature (℃)</th> <th>Time (min)</th> </tr> </thead> <tbody> <tr> <td>1</td> <td>-30±3</td> <td>30</td> </tr> <tr> <td>2</td> <td>25±2</td> <td>3</td> </tr> <tr> <td>3</td> <td>100±3</td> <td>30</td> </tr> <tr> <td>4</td> <td>25±2</td> <td>3</td> </tr> </tbody> </table>	Step	Temperature (℃)	Time (min)	1	-30±3	30	2	25±2	3	3	100±3	30	4	25±2	3
Step	Temperature (℃)	Time (min)																
1	-30±3	30																
2	25±2	3																
3	100±3	30																
4	25±2	3																
1-2-3	Humidity Resistance		Temperature: 40±2℃ Relative Humidity: 90 ~ 95% Time: 1000hrs Measured after exposure in the room condition for 24hrs															
1-2-4	High Temperature Resistance		Temperature: 85±3℃ Applied Current: Rated Current Time: 1000hrs Measured after exposure in the room condition for 24hrs															
1-2-5	Low Temperature Resistance		Temperature: -30±3℃ Time: 1000hrs Measured after exposure in the room condition for 24hrs															

## BPSC00050530 Series Specification

### Reflow Soldering Profile

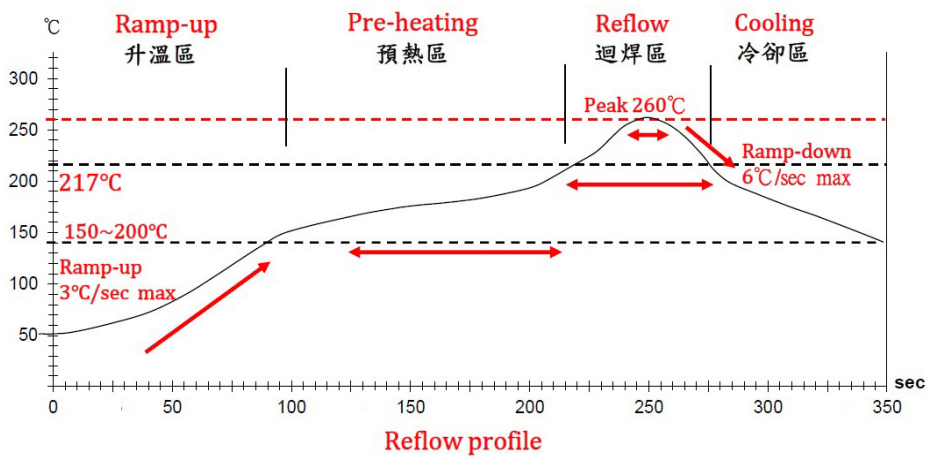

Lead-Free(LF)標準溫度分析範圍

Refer to J-STD-020C

管制項目 Item.	升温區 Ramp-up	預熱區 Pre-heating	迴焊區 Reflow	Peak Temp	冷卻區 Cooling
溫度範圍 Temp.scope	R.T ~ 150°C	150°C ~ 200°C	217°C	260±5°C	Peak Temp.~150°C
標準時間 Time spec.	-	60 ~ 180 sec	60 ~ 150 sec	20 ~ 40 sec	-
實際時間 Time result	-	75 ~ 100 sec	90 ~ 120 sec	20 ~ 35 sec	-

## BPSC00050530 Series Specification

### 10 Packaging:

#### 10.1 Packaging -Cover Tape

The force for tearing off cover tape is 10 to 130 grams in the arrow direction.

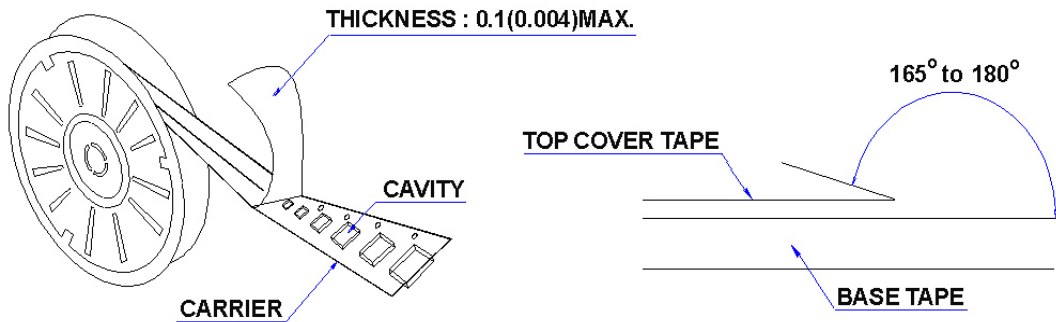

#### 10.2 Packaging Quantity

TYPE	PCS/REEL
050530	2000

#### 10.3 Reel Dimensions

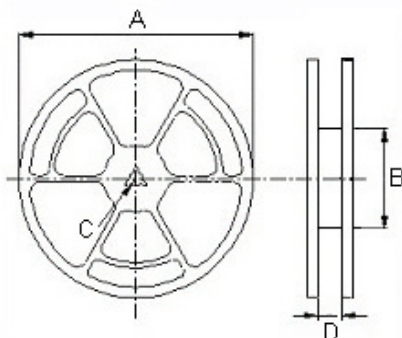

Dimensions in mm

TYPE	A	B	C	D
050530	330	100	13	13.4

## BPSC00050530 Series Specification

### 10 Packaging:

#### 10.4 Tape Dimensions in mm

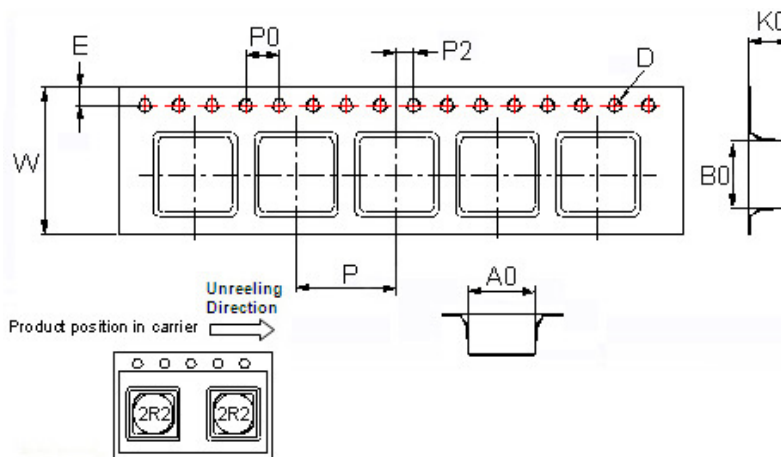

TYPE	A0	B0	K0	D	E	W	P	P0	P2
050530	5.3	5.3	3.4	1.5	1.75	12	8	4	2

### 11 Recommended Land Pattern:

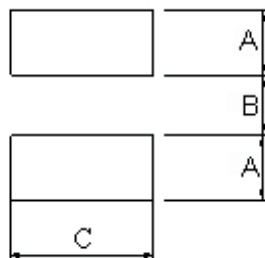

Dimensions in mm

TYPE	A	B	C
050530	1.9	1.5	5.3

### 12 Note:

1. Please make sure that your product has been evaluated and confirmed against your specifications when our product is mounted to your product.
2. Do not knock nor drop.
3. All the items and parameters in this product specification have been prescribed on the premise that our product is used for the purpose, under the condition and in the environment agreed upon between you and us. You are requested not to use our product deviating from such agreement.
4. Please keep the distance between transformer/coil and other components (refer to the standard IEC 950)
5. The moisture sensitivity level (MSL) of products is classified as level 1.

# BPSC00050530 Series Specification

**13** Graph:

BPSC000505301R2□S0

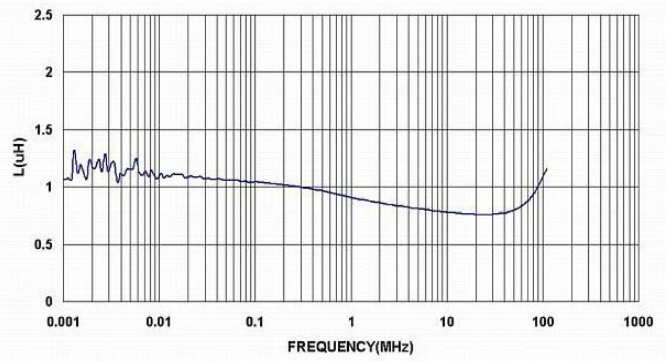
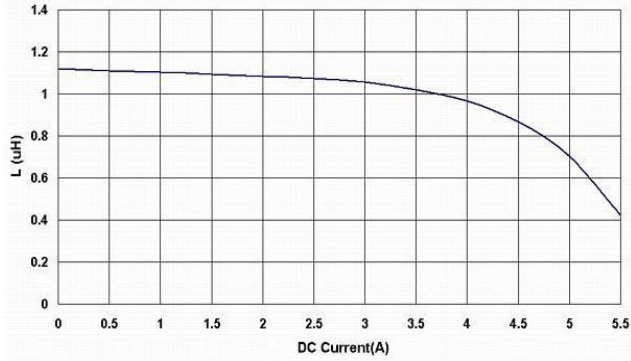

BPSC000505301R8□S0

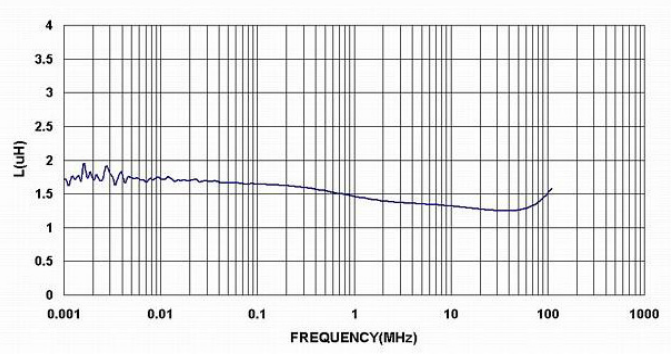
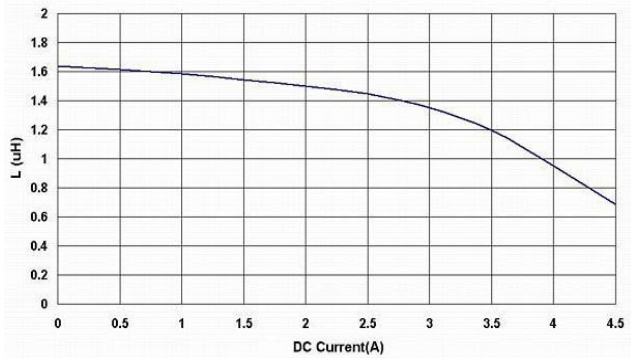

BPSC000505302R0□S0

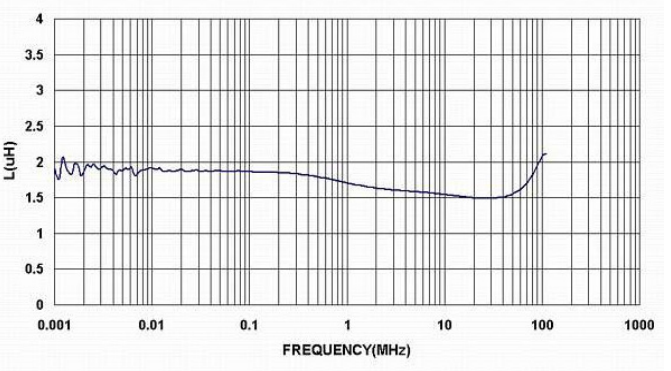
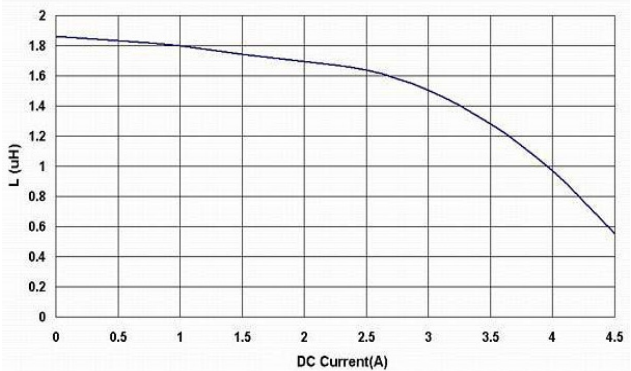

BPSC000505302R2□S0

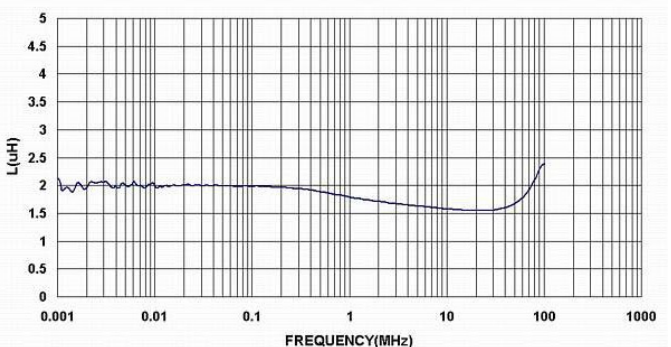
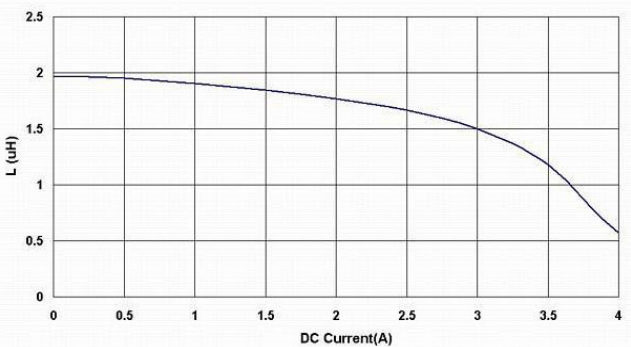

# BPSC00050530 Series Specification

**13** Graph:

BPSC000505302R7□S0

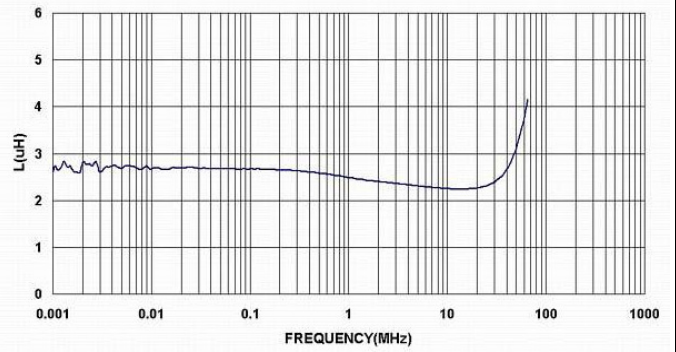

BPSC000505303R3□S0

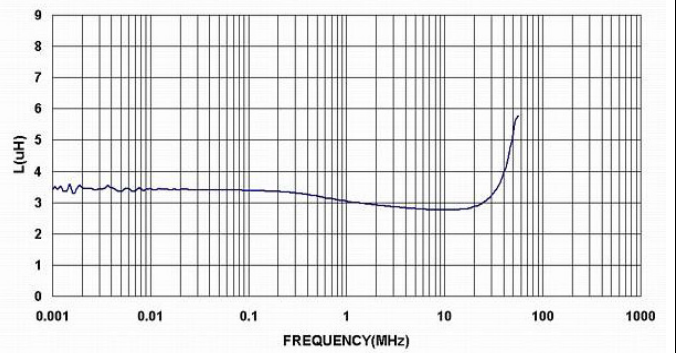
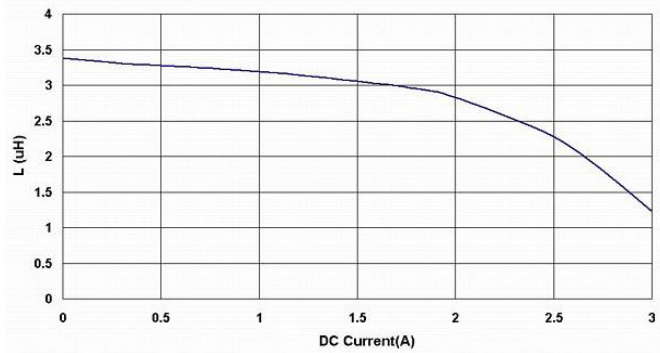

BPSC000505303R9□S0

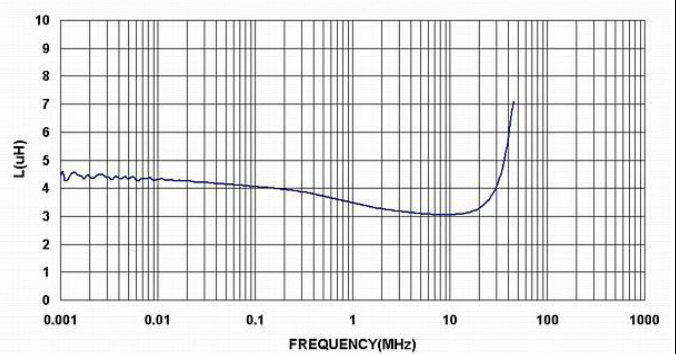
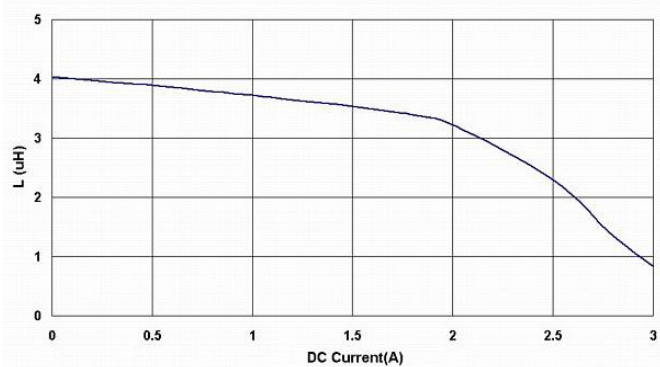

BPSC000505304R7□S0

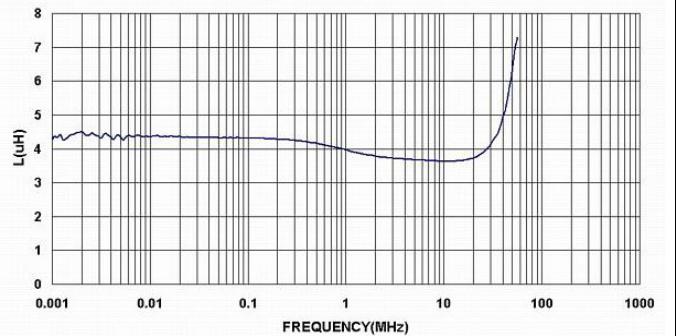
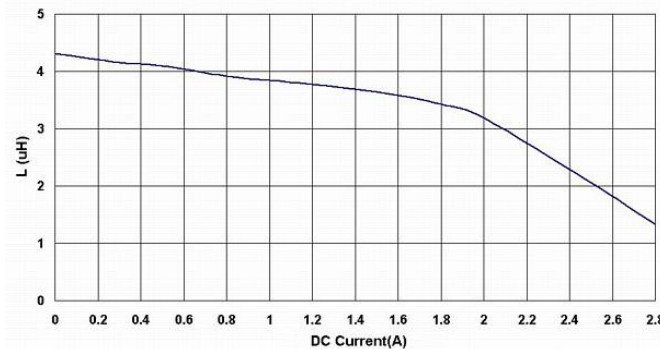

# BPSC00050530 Series Specification

**13** Graph:

BPSC000505305R6□S0

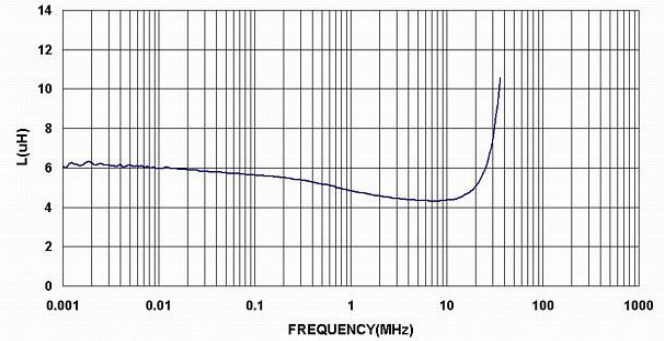
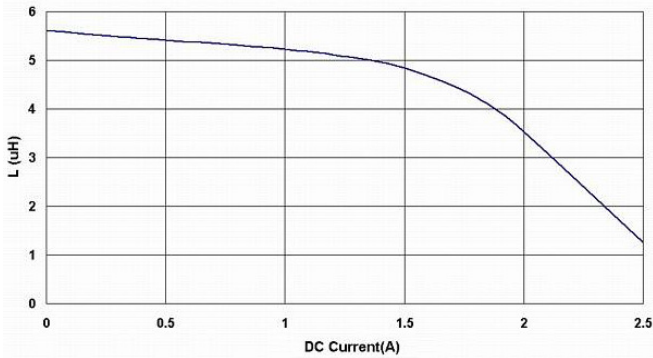

BPSC000505306R8□S0

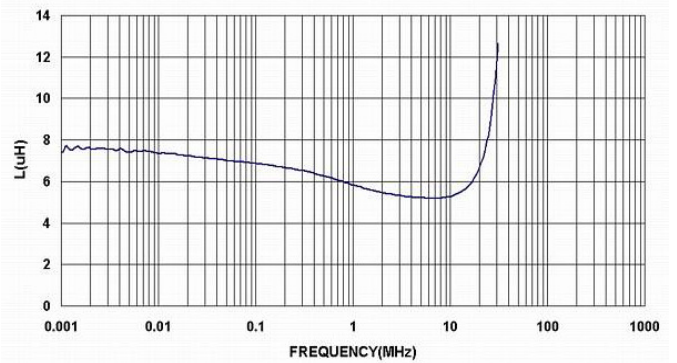
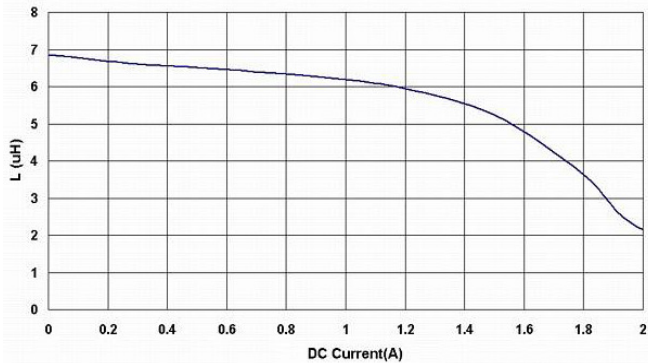

BPSC000505308R2□S0

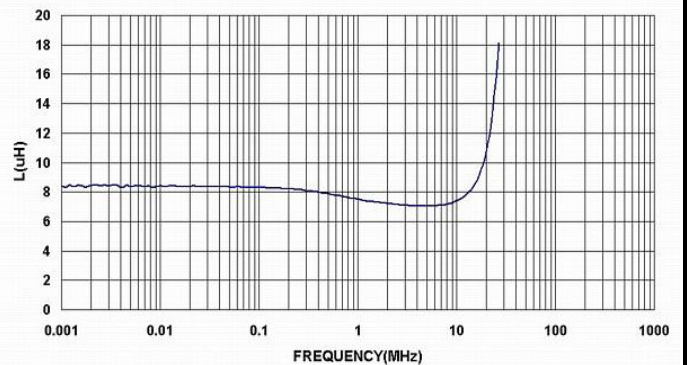
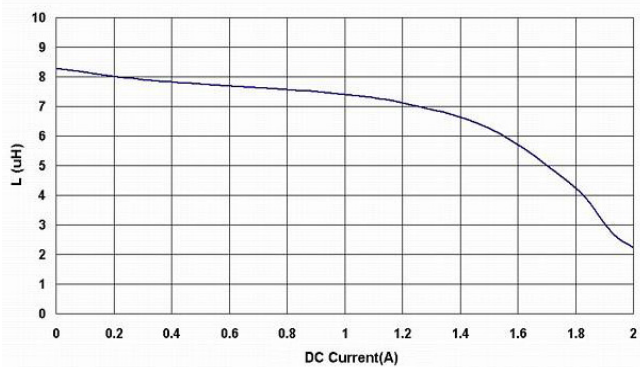

BPSC00050530100□S0

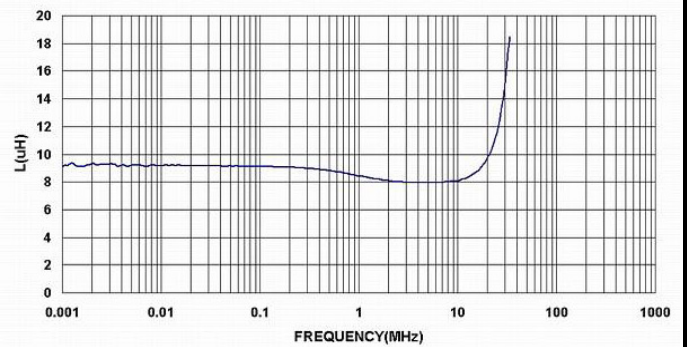
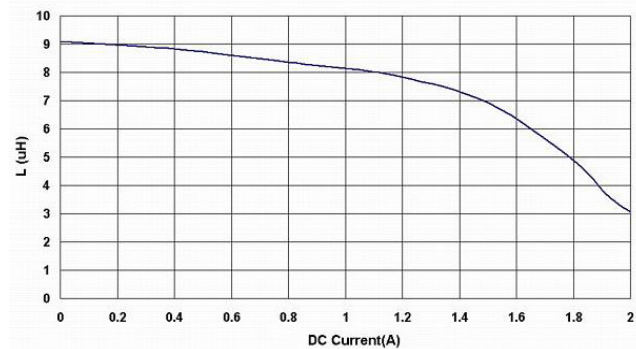

# BPSC00050530 Series Specification

**13** Graph:

BPSC00050530120□S0

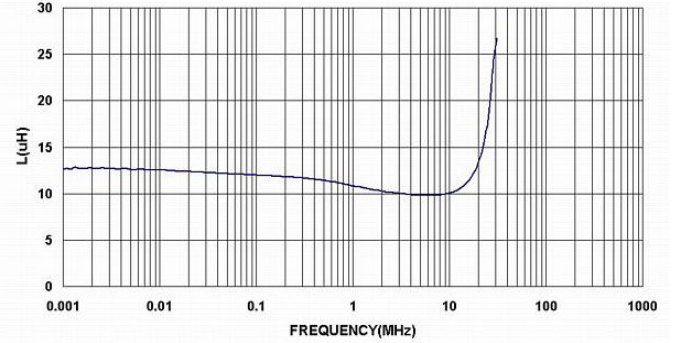
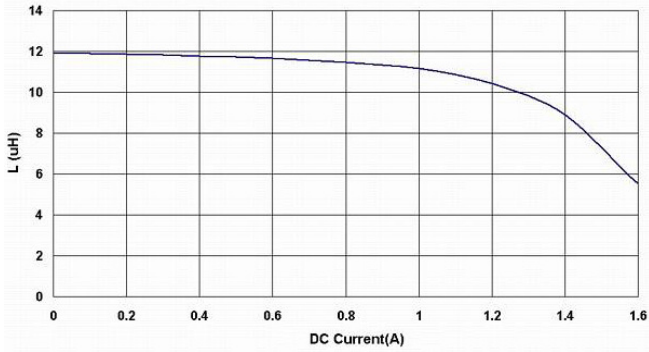

BPSC00050530150□S0

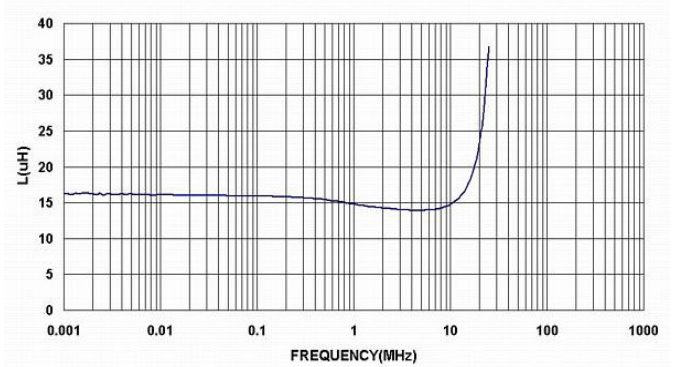
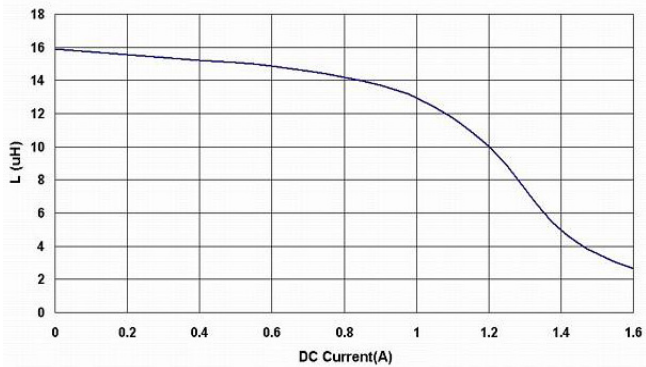

BPSC00050530180□S0

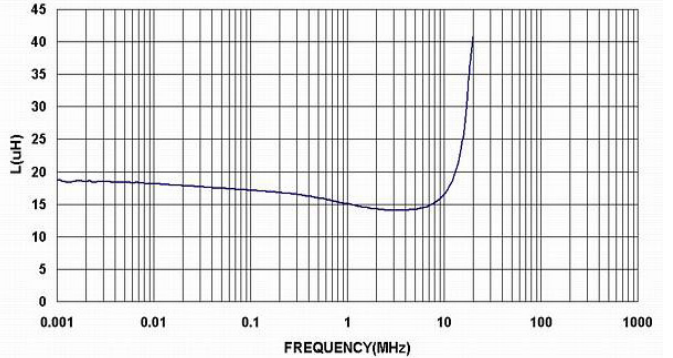
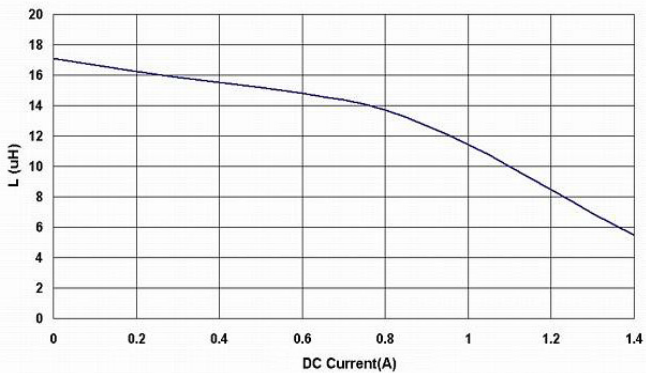

BPSC00050530220□S0

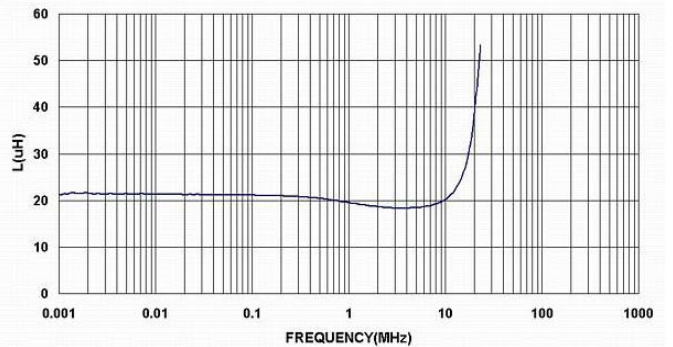
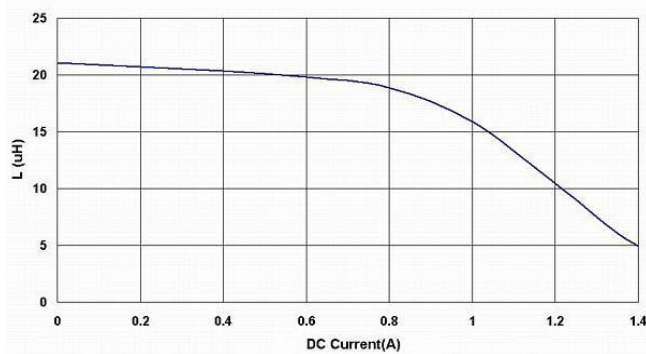

# BPSC00050530 Series Specification

**13** Graph:

BPSC00050530270□S0

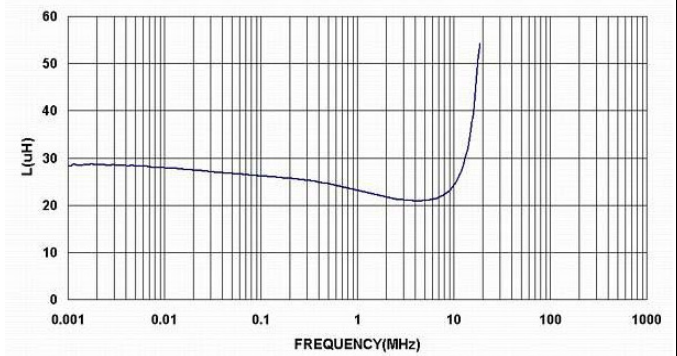
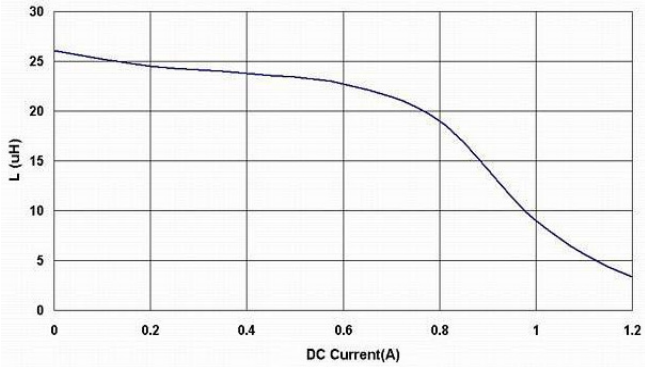

BPSC00050530330□S0

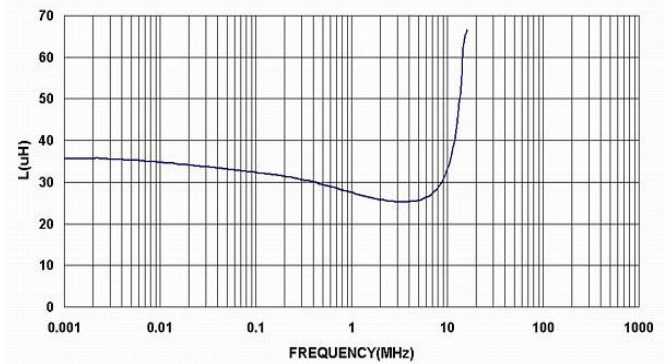
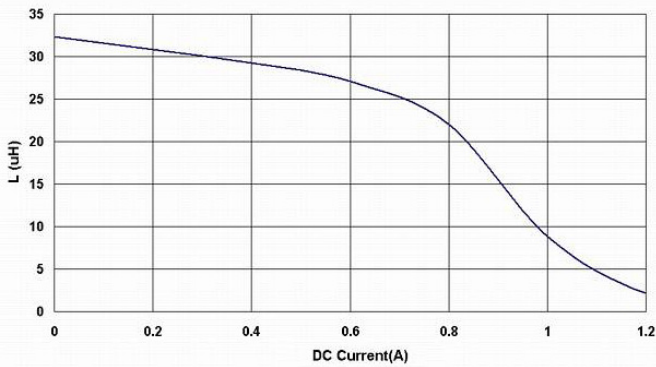

BPSC00050530390□S0

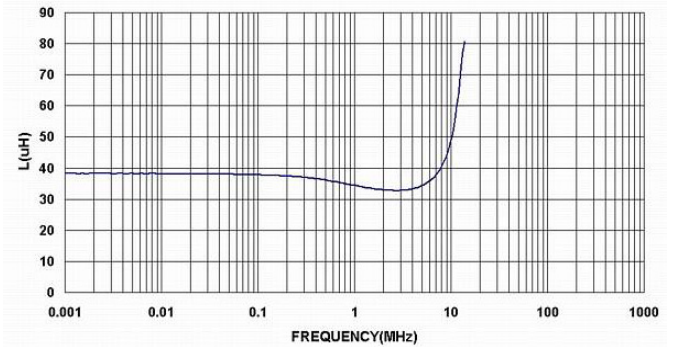
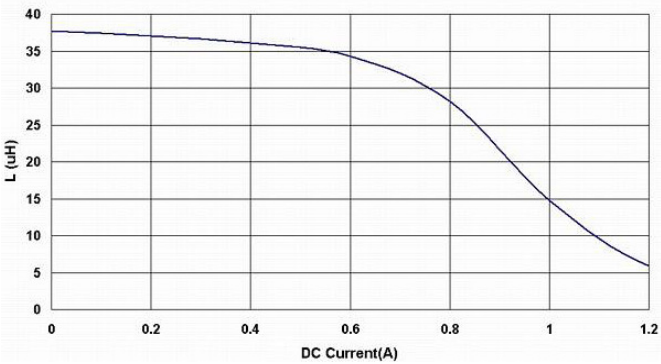

BPSC00050530470□S0

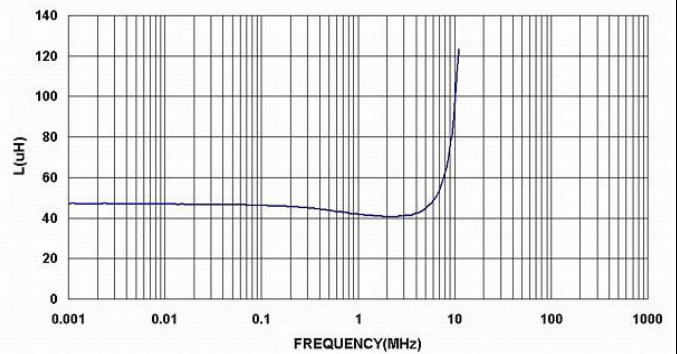
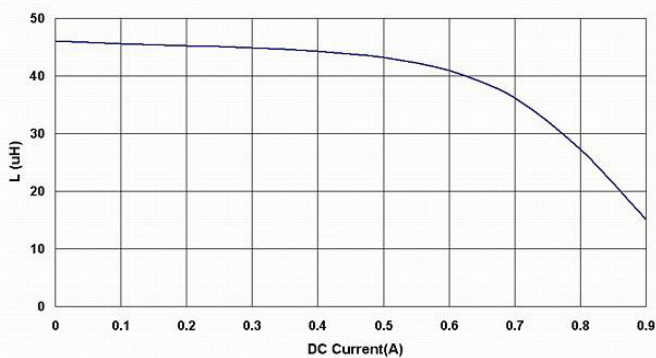

# BPSC00050530 Series Specification

**13** Graph:

BPSC00050530560□S0

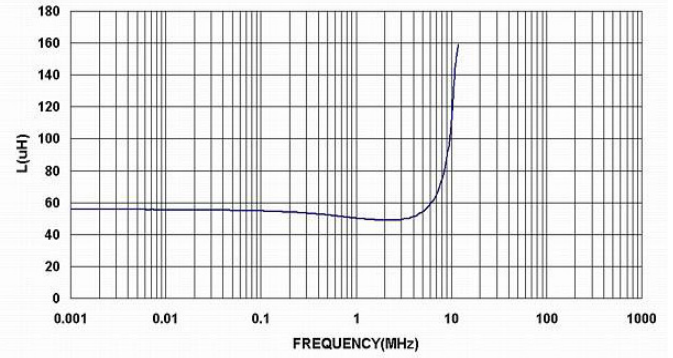
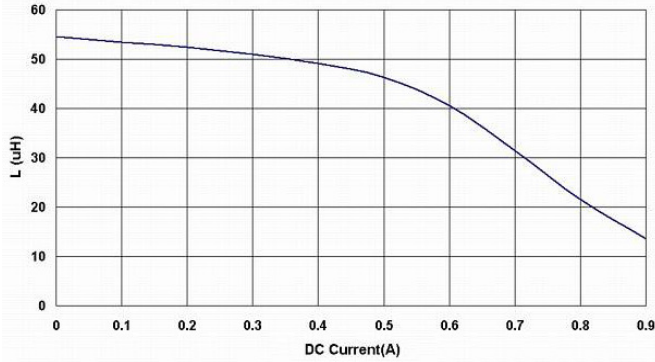

BPSC00050530680□S0

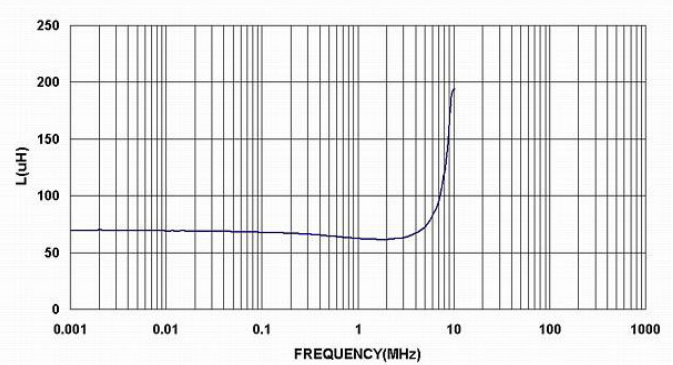
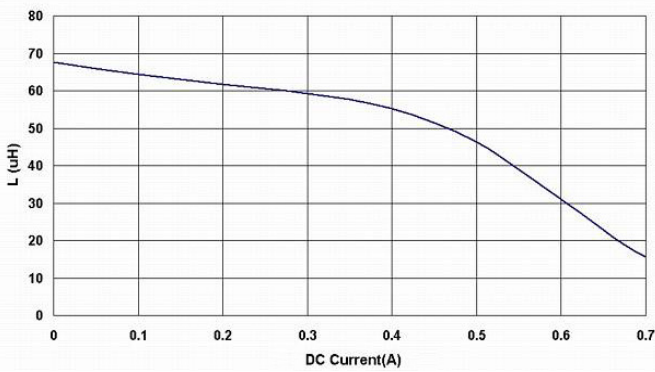

BPSC00050530820□S0

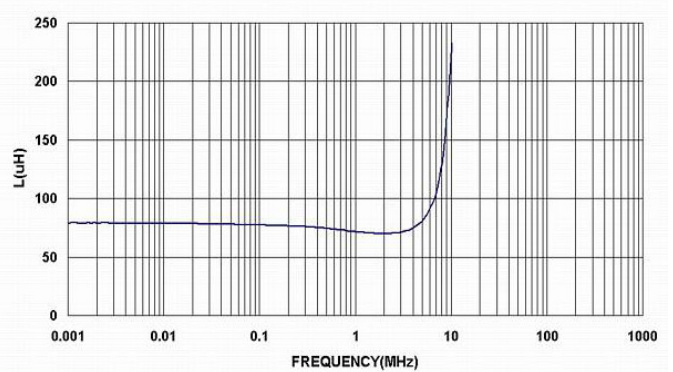
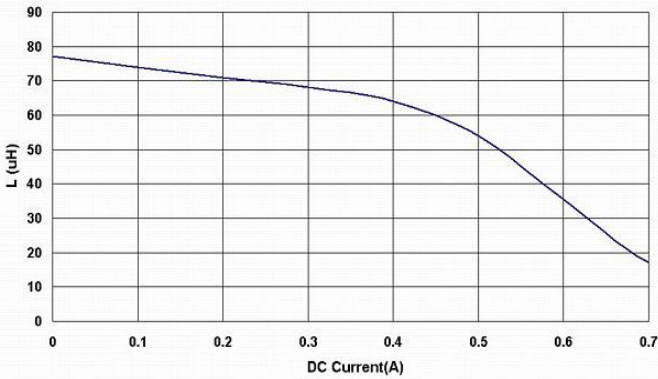

BPSC00050530101□S0

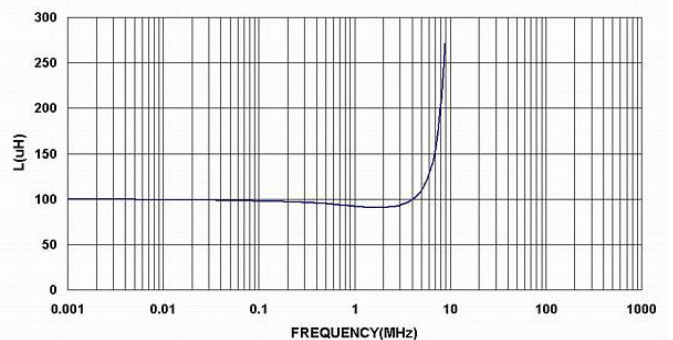
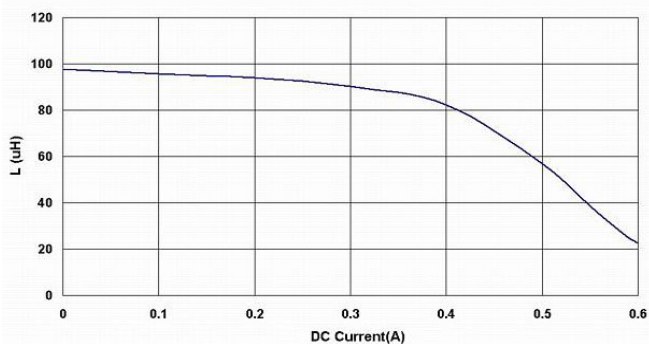

# BPSC00050530 Series Specification

## 13 Graph:

BPSC00050530121□S0

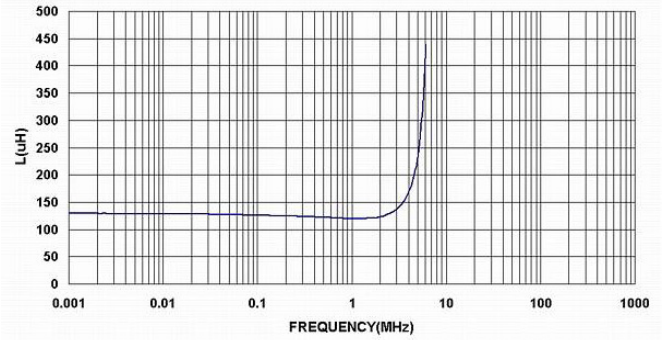
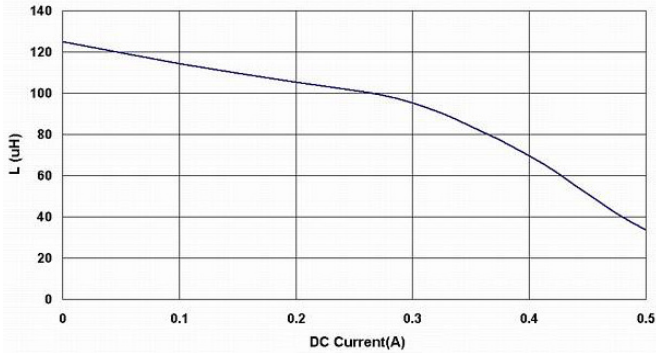

BPSC00050530151□S0

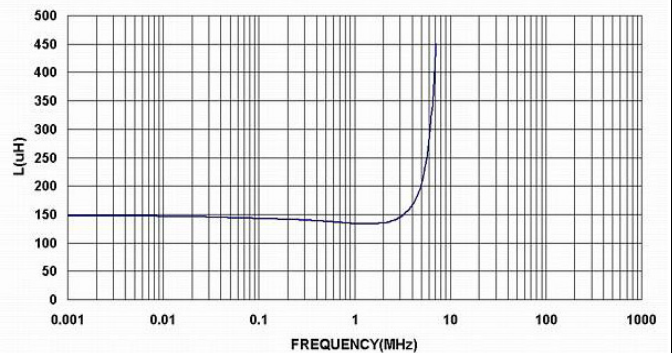
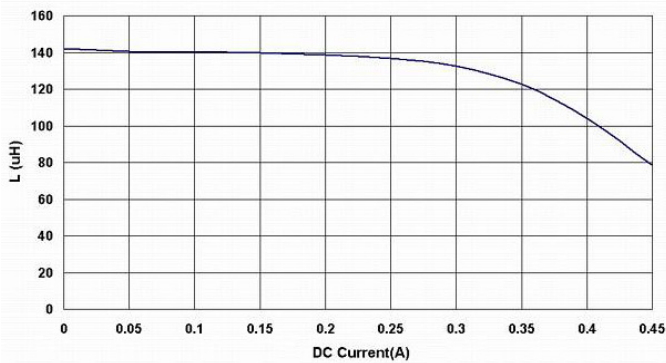

BPSC00050530181□S0

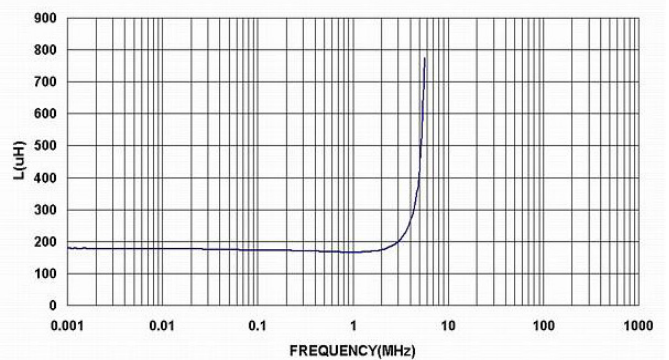
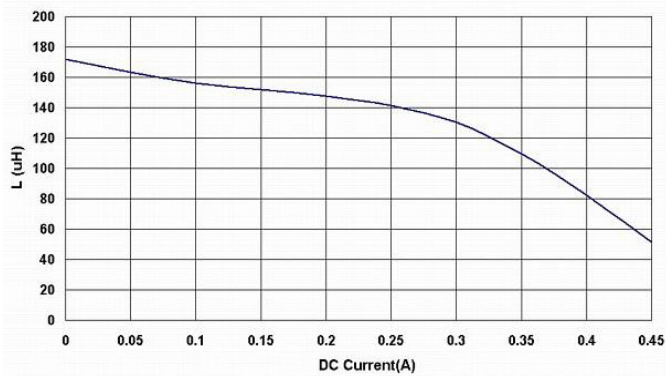

BPSC00050530221□S0

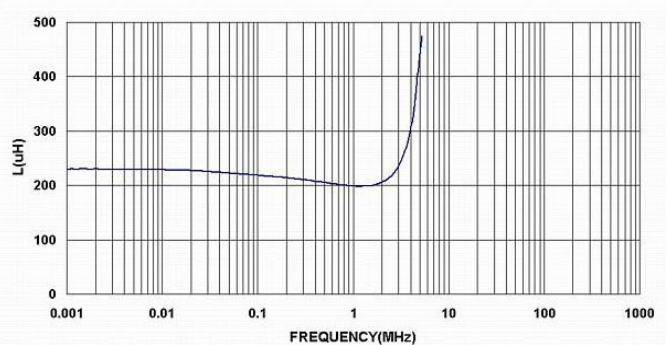
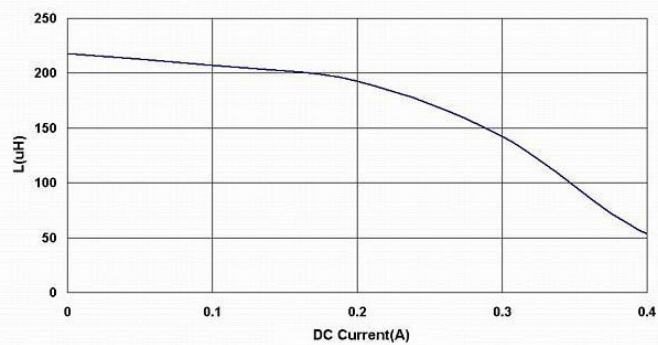

# BPSC00050530 Series Specification

**13** Graph:

BPSC00050530331□S0

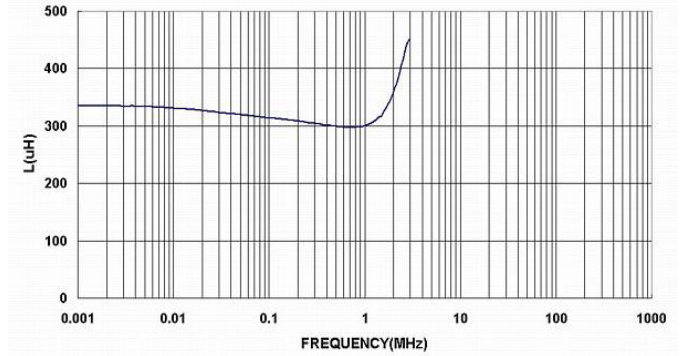
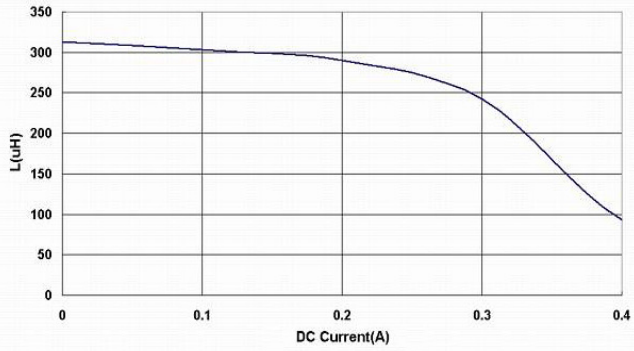

BPSC00050530391□S0

