

Power Inductor



BPSC Series



Overview

Power inductors are passive electronic components used in various circuits to store energy in a magnetic field when electrical current flows through them. They are critical in filtering, energy storage, and noise suppression in power electronic systems. They are designed to handle higher currents and are optimized for minimal power loss and thermal efficiency.

Benefits

1. Ferrite SMD Shielded Type
2. No thermal aging

Applications

1. AP Routers, STBs
2. LCD TVs and monitors
3. Game consoles
4. LED lightings
5. DC/DC converters

Product Information

Series	L (mm)	W(mm)	T (mm)	Inductance (μH)
BPSC	3.2	3.2	1.55	0.47 ~ 3300
	3.2	3.2	2.0	
	4.0	4.0	1.2	
	4.0	4.0	1.8	
	4.0	4.0	3.0	
	4.7	4.7	2.0	
	4.7	4.7	3.0	
	4.7	4.7	4.0	
	5.7	5.7	2.0	
	5.7	5.7	3.0	
	6.7	6.7	3.0	
	7.3	7.3	3.4	
	7.0	7.0	4.0	
	7.3	7.3	4.5	
	8.3	8.3	4.5	
	10.3	10.5	3.1	
	10.3	10.5	4	
	10.3	10.5	5.1	
12.5	12.5	4.5		
12.5	12.5	6		
12.5	12.5	8		
12.0	12.0	10.0		



BPSC00131380 Series Specification

1 Scope: This specification applies to SMD Shielded Power Inductors

2 Part Numbering:

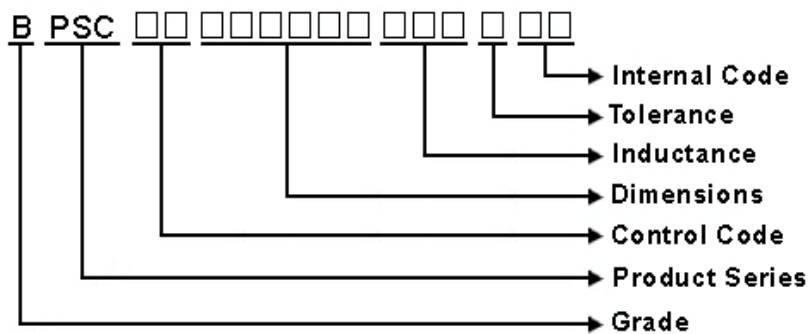

3 Rating:

Operating Temperature: - 40°C ~ + 125°C (Including self temp. rise)

Storage Temperature: - 40°C ~ + 125°C(For after the circuit board is mounted)

Storage Temperature: (on tape & reel): -20°C to +40°C; 75% RH max.

4 Marking:



Ex Marking: 100

Marking color : Black

5 Standard Testing Condition

	Unless otherwise specified	In case of doubt
Temperature	Ordinary Temperature(15 to 35°C)	20 to 30°C
Humidity	Ordinary Humidity(25 to 85% RH)	50 to 80 %RH

BPSC00131380 Series Specification

6 Configuration and Dimensions and Unit Weight:

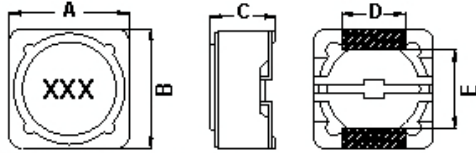

Dimensions in mm

TYPE	A	B	C	D	E
131380	12.5 Max.	12.5 Max.	8.0 Max.	5	7.6

Net Weight (grms)

SIZE CODE	Net Weight (grms)
131380	4.44(Typ.)

7 Electrical Characteristics:

Part No.	Inductance (uH)	Test Freq.	RDC (Ω)Max.	Isat(A) Max(Typ)	Irms (A)Typ.	Tolerance	Marking
BPSC001313801R5□00	1.5	100 kHz,1 V	0.0074	21.6(28.0)	9.5	T	1R5
BPSC001313802R2□00	2.2	100 kHz,1 V	0.0089	17.6(24.0)	9	T,N	2R2
BPSC001313802R4□00	2.4	100 kHz,1 V	0.0089	17.6(24.0)	9	T,N	2R4
BPSC001313803R3□00	3.3	100 kHz,1 V	0.0099	14.6(19.4)	9.5	T,N	3R3
BPSC001313803R5□00	3.5	100 kHz,1 V	0.0123	13.8(17.4)	7.7	T,N	3R5
BPSC001313804R7□00	4.7	100 kHz,1 V	0.0158	12.3(15.4)	6.8	M,T	4R7
BPSC001313806R1□00	6.1	100 kHz,1 V	0.0176	10.9(13.8)	6.6	M,T,N	6R1
BPSC001313806R8□00	6.8	100 kHz,1 V	0.018	10.8(13.7)	6.5	M,T	6R8
BPSC001313807R6□00	7.6	100 kHz,1 V	0.02	10.0(12.6)	5.9	M,T	7R6
BPSC00131380100□00	10	1 kHz,1 V	0.022	8.9(11.2)	5.4	M,T	100
BPSC00131380120□00	12	1 kHz,1 V	0.03	7.4(9.4)	4.3	M,T	120
BPSC00131380150□00	15	1 kHz,1 V	0.034	7.1(9.0)	4.1	M,T	150
BPSC00131380180□00	18	1 kHz,1 V	0.0392	6.5(8.2)	3.9	M,T	180
BPSC00131380220□00	22	1 kHz,1 V	0.048	5.8(7.5)	3.2	M,T	220
BPSC00131380270□00	27	1 kHz,1 V	0.052	5.3(6.7)	3.1	M,T	270
BPSC00131380330□00	33	1 kHz,1 V	0.0648	4.8(6.1)	3	M,T	330
BPSC00131380390□00	39	1 kHz,1 V	0.065	3.9(5.6)	3	M,T	390
BPSC00131380470□00	47	1 kHz,1 V	0.1	3.6(5.2)	2.5	M,T	470
BPSC00131380560□00	56	1 kHz,1 V	0.11	3.4(4.8)	2.35	M,T	560
BPSC00131380680□00	68	1 kHz,1 V	0.12	2.8(4.1)	2.3	M,T	680
BPSC00131380820□00	82	1 kHz,1 V	0.16	2.7(4.0)	1.95	M,T	820
BPSC00131380101□00	100	1 kHz,1 V	0.17	2.5(3.5)	1.9	M,T	101
BPSC00131380121□00	120	1 kHz,1 V	0.19	2.2(3.2)	1.8	M,T	121
BPSC00131380151□00	150	1 kHz,1 V	0.25	2.0(2.9)	1.6	M,T	151
BPSC00131380181□00	180	1 kHz,1 V	0.31	1.8(2.6)	1.37	M,T	181

NOTE: □-tolerance M=±20% / T =±30% / N=+40% -20%

1. Operating temperature range - 4 0 °C ~ 1 2 5 °C(Including self - temperature rise)
2. Isat for Inductance drop 35% from its value without current.
3. I rms for a 40 °C temperature rise from 25 °C ambient.

BPSC00131380 Series Specification

Part No.	Inductance (μ H)	Test Freq.	RDC (Ω)Max.	Isat(A) Max(Typ)	Irms (A)Typ.	Tolerance	Marking
BPSC00131380221□00	220	1 kHz,1 V	0.35	1.7(2.4)	1.3	M,T	221
BPSC00131380271□00	270	1 kHz,1 V	0.43	1.5(2.2)	1.1	M,T	271
BPSC00131380331□00	330	1 kHz,1 V	0.51	1.2(2.0)	1.08	M,T	331
BPSC00131380391□00	390	1 kHz,1 V	0.6	1.1(1.6)	0.95	M,T	391
BPSC00131380471□00	470	1 kHz,1 V	0.71	0.99(1.6)	0.88	M,T	471
BPSC00131380561□00	560	1 kHz,1 V	0.88	0.95(1.4)	0.85	M,T	561
BPSC00131380681□00	680	1 kHz,1 V	1.04	0.84(1.2)	0.75	M,T	681
BPSC00131380821□00	820	1 kHz,1 V	1.36	0.77(1.1)	0.7	M,T	821
BPSC00131380102□00	1000	1 kHz,1 V	1.66	0.73(1.00)	0.59	M,T	102

BPSC00131380 Series Specification

8 BPSC00131380 Series

8.1 Construction:

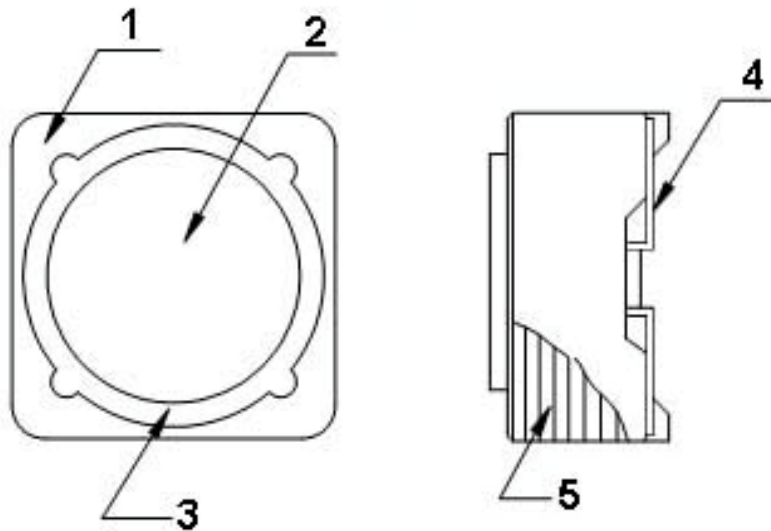

8.2 Material List:

No	Part	Material
1	CORE	FERRITE
2	CORE	FERRITE
3	EPOXY	
4	TERMINAL	TERMINAL COPPER
5	WIRE	MAGNET WIRE

BPSC00131380 Series Specification

9 Reliability Of Ferrite Wire Wound Power Inductor

1-1.Mechanical Performance

No	Item	Specification	Test Method
1-1-1	Vibration	Appearance: No damage Inductance: within $\pm 10\%$ of initial value	Test device shall be soldered on the substrate Oscillation Frequency: 10 to 55 to 10Hz for 1min Amplitude: 1.5mm Time: 2hrs for each axis (X, Y & Z), total 6hrs
1-1-2	Resistance to Soldering Heat	Appearance: No damage	Pre-heating: 150°C, 1min Solder Composition: Sn/Ag3.0/Cu0.5 Solder Temperature: 260 \pm 5°C Immersion Time: 10 \pm 1sec
1-1-3	Solder ability	The electrodes shall be at least 95% covered with new solder coating	Pre-heating: 150°C, 1min Solder Composition: Sn/Ag3.0/Cu0.5 Solder Temperature: 245 \pm 5°C Immersion Time: 4 \pm 1sec
1-1-4	Resistance to solvent	There must be no change in appearance or obliteration of marking.	Inductors must withstand 6 minutes of alcohol or water.

1-2.Environmental Performance

No	Item	Specification	Test Method															
1-2-1	Temperature Shock	Appearance: No damage Inductance: within $\pm 10\%$ of initial value	10 cycles (Air to Air) 1 cycles shall consist of: 30 minutes exposure to -55 °C 30 minutes exposure to 125 °C 15 seconds maximum transition between temperatures															
1-2-2	Temperature Cycle		One cycle: <table border="1"> <thead> <tr> <th>Step</th> <th>Temperature (°C)</th> <th>Time (min)</th> </tr> </thead> <tbody> <tr> <td>1</td> <td>-40\pm3</td> <td>30</td> </tr> <tr> <td>2</td> <td>25\pm2</td> <td>3</td> </tr> <tr> <td>3</td> <td>125\pm3</td> <td>30</td> </tr> <tr> <td>4</td> <td>25\pm2</td> <td>3</td> </tr> </tbody> </table>	Step	Temperature (°C)	Time (min)	1	-40 \pm 3	30	2	25 \pm 2	3	3	125 \pm 3	30	4	25 \pm 2	3
Step	Temperature (°C)		Time (min)															
1	-40 \pm 3		30															
2	25 \pm 2		3															
3	125 \pm 3	30																
4	25 \pm 2	3																
1-2-3	Humidity Resistance	Temperature: 40 \pm 2°C Relative Humidity: 90 ~ 95% Time: 1000hrs Measured after exposure in the room condition for 24hrs																
1-2-4	Heat Life	Temperature: 85 \pm 3°C Applied Current: Rated Current Time: 1000hrs Measured after exposure in the room condition for 24hrs																
1-2-5	Cold Resistance	Temperature: -40 \pm 3°C Time: 1000hrs Measured after exposure in the room condition for 24hrs																

BPSC00131380 Series Specification

Reflow Soldering Profile

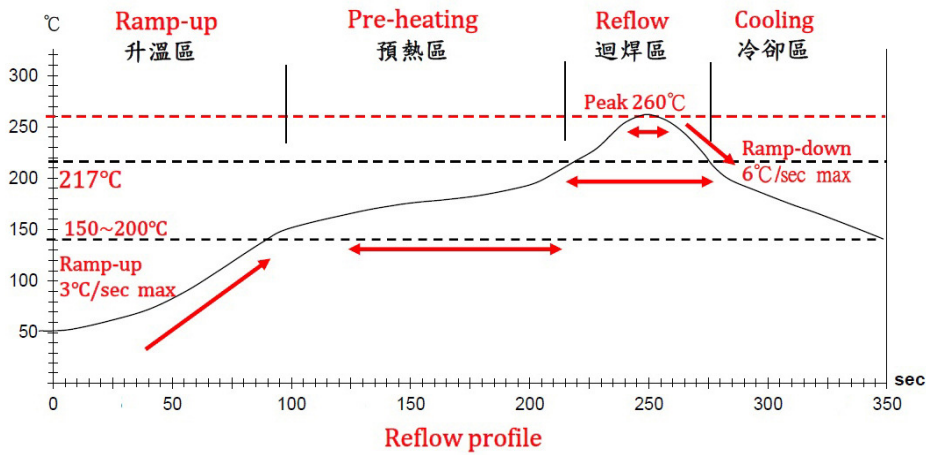

Lead-Free(LF)標準溫度分析範圍

Refer to J-STD-020C

管制項目 Item.	升溫區 Ramp-up	預熱區 Pre-heating	迴焊區 Reflow	Peak Temp	冷卻區 Cooling
溫度範圍 Temp.scope	R.T ~ 150°C	150°C ~ 200°C	217°C	260±5°C	Peak Temp.~150°C
標準時間 Time spec.	-	60 ~ 180 sec	60 ~ 150 sec	20 ~ 40 sec	-
實際時間 Time result	-	75 ~ 100 sec	90 ~ 120 sec	20 ~ 35 sec	-

BPSC00131380 Series Specification

10 Packaging:

10.1 Packaging -Cover Tape

The force for tearing off cover tape is 10 to 130 grams in the arrow direction.

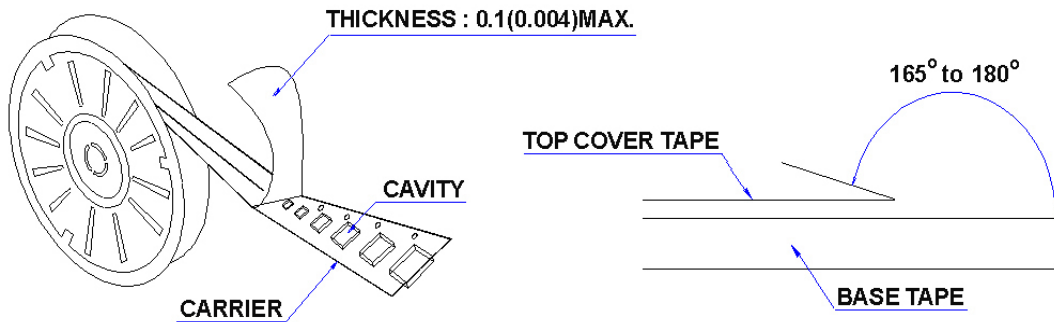

10.2 Packaging Quantity

TYPE	PCS/REEL
131380	500

10.3 Reel Dimensions

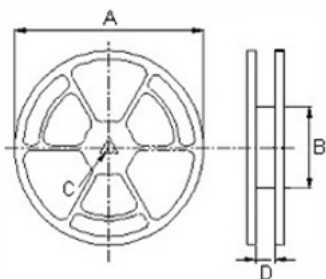

Dimensions in mm

TYPE	A	B	C	D
131380	330	100	13	24.4

BPSC00131380 Series Specification

10 Packaging:

10.4 Tape Dimensions in mm

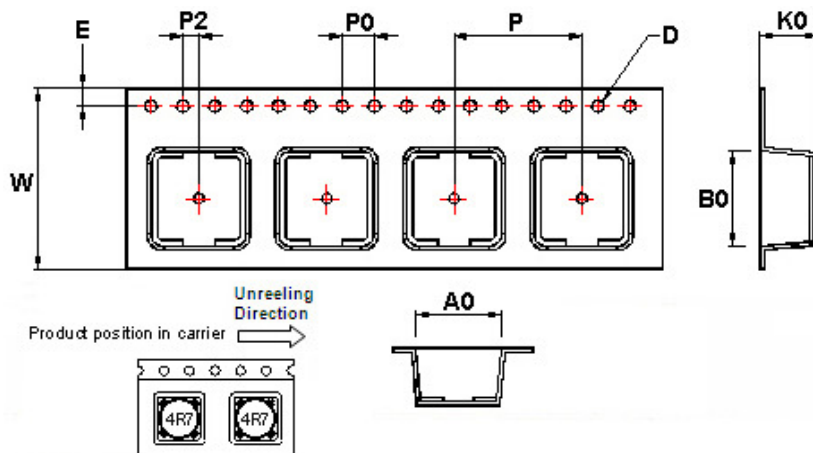

TYPE	A0	B0	K0	D	E	W	P	P0	P2
131380	12.6	12.6	8.7	1.55	1.75	24	16	4	2

11 Recommended Land Pattern:

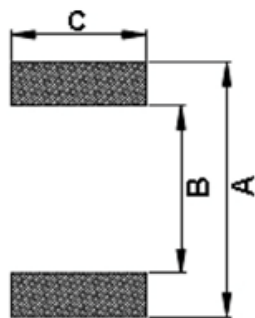

Dimensions in mm

TYPE	A	B	C
131380	13	7	5.4

12 Note:

1. Please make sure that your product has been evaluated and confirmed against your specifications when our product is mounted to your product.
2. Do not knock nor drop.
3. All the items and parameters in this product specification have been prescribed on the premise that our product is used for the purpose, under the condition and in the environment agreed upon between you and us. You are requested not to use our product deviating from such agreement.
4. Please keep the distance between transformer/coil and other components (refer to the standard IEC 950)
5. The moisture sensitivity level (MSL) of products is classified as level 1.

BPSC00131380 Series Specification

13 Graph:

BPSC001313801R5□00

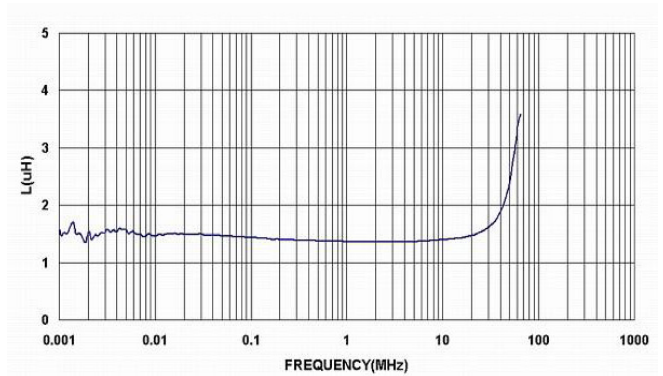
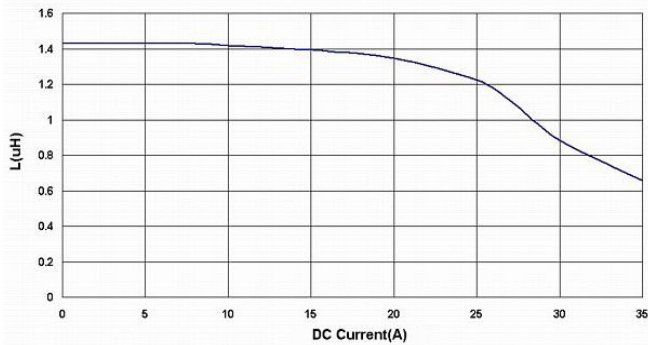

BPSC001313802R2□00

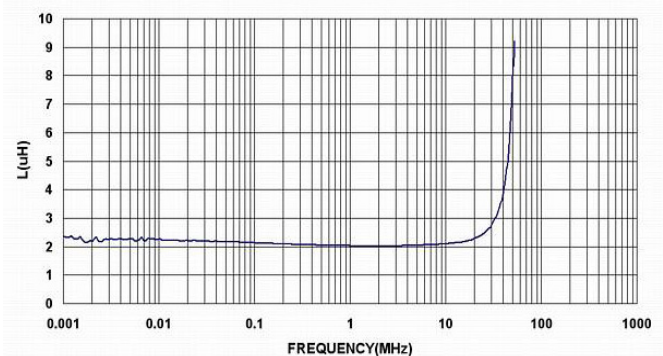
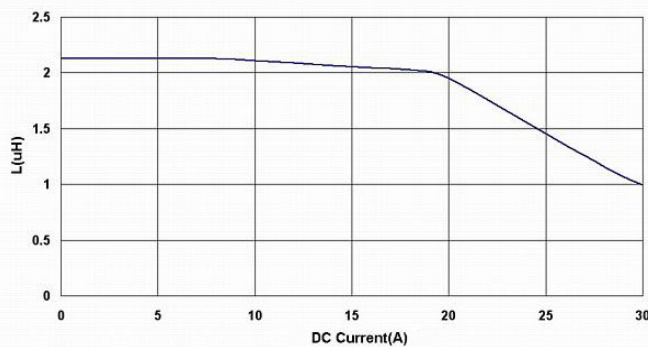

BPSC001313802R4□00

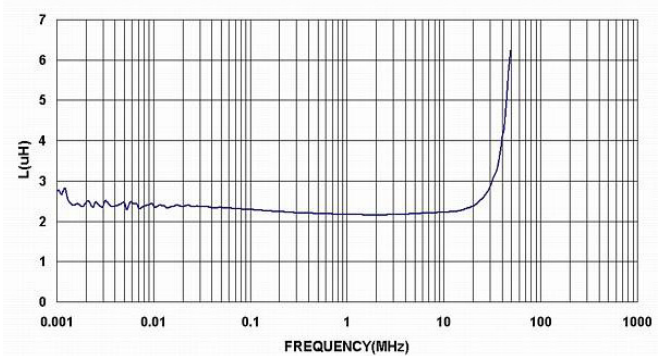
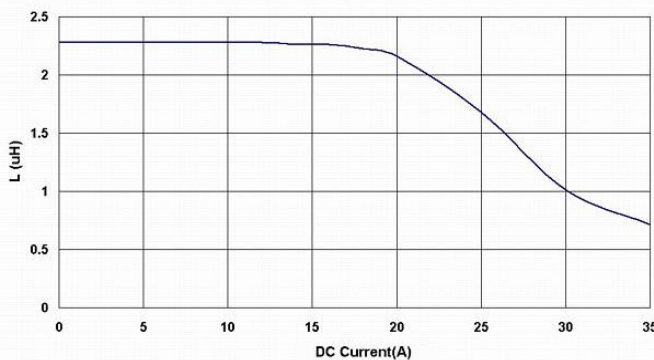

BPSC001313803R3□00

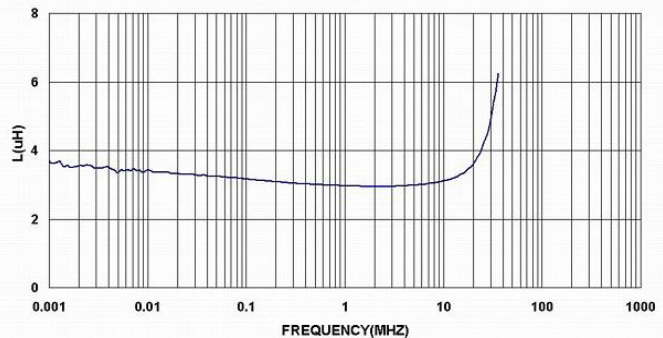
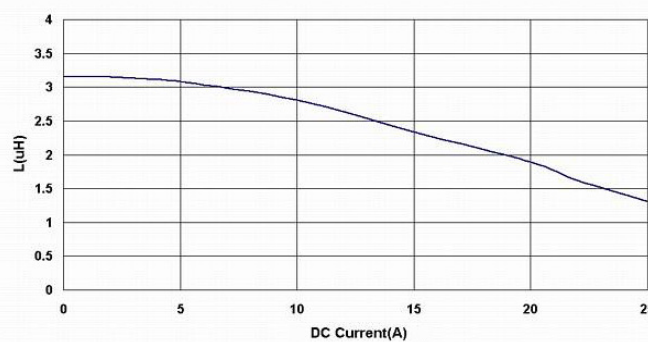

BPSC00131380 Series Specification

13 Graph:

BPSC001313803R5□00

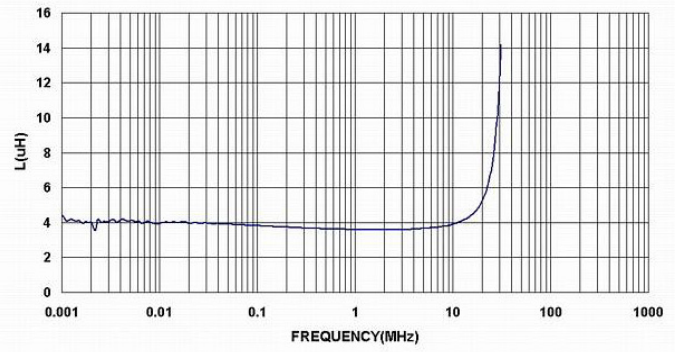
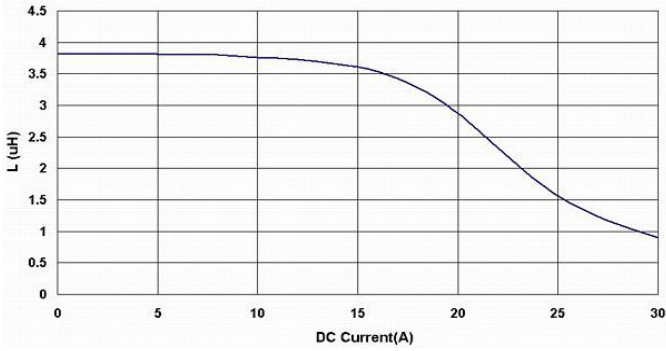

BPSC001313804R7□00

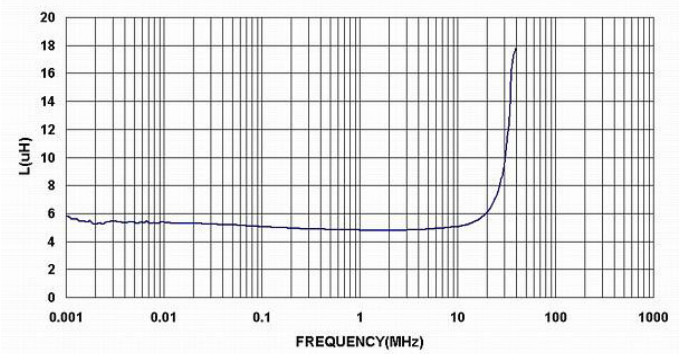
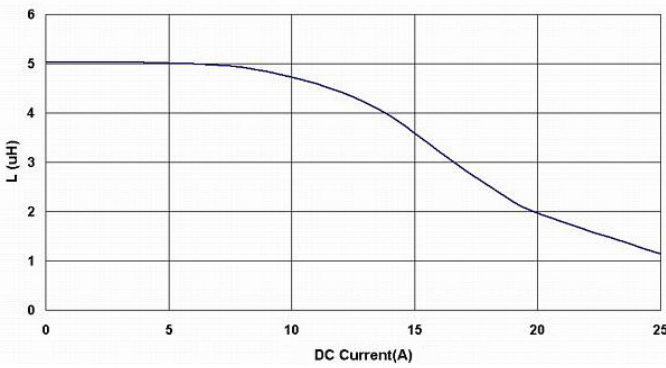

BPSC001313806R1□00

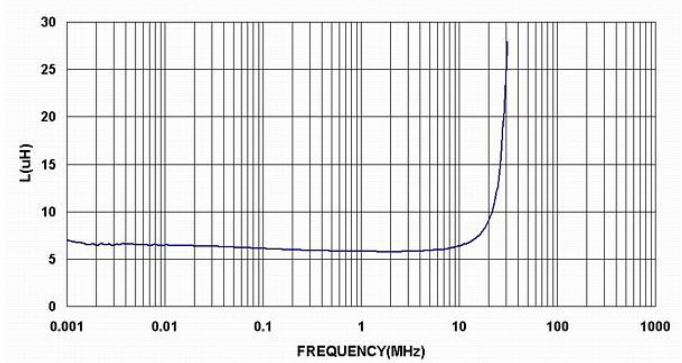
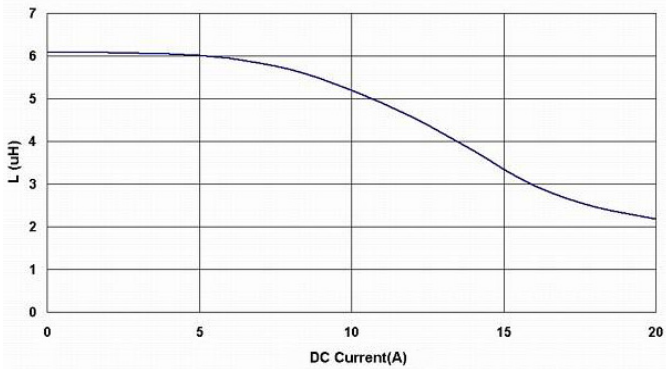

BPSC001313806R8□00

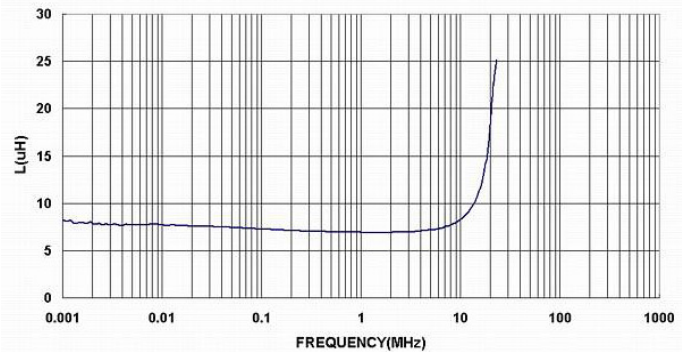
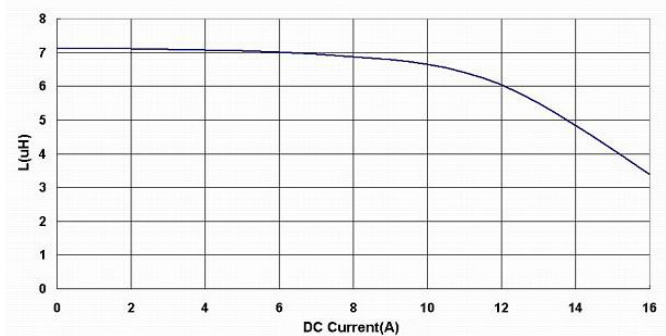

BPSC00131380 Series Specification

13 Graph:

BPSC001313807R6□00

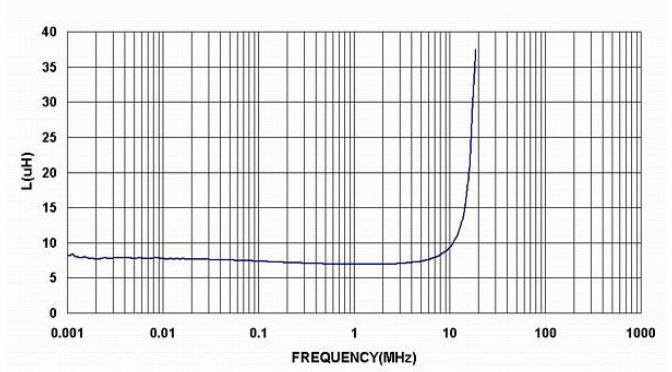
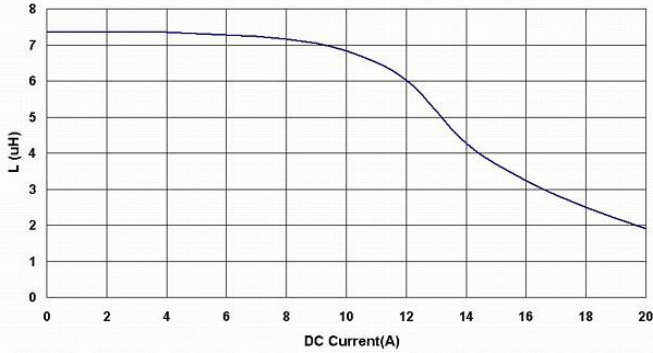

BPSC00131380100□00

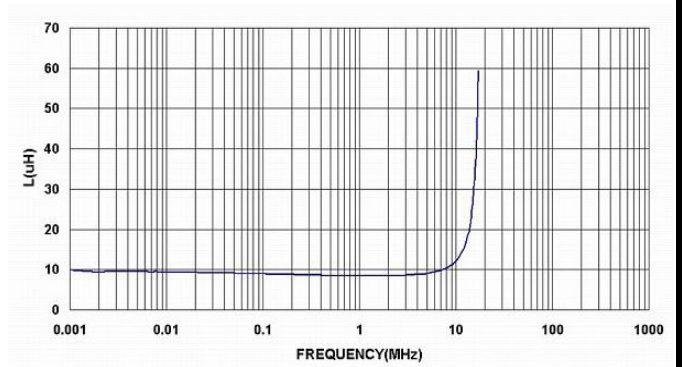
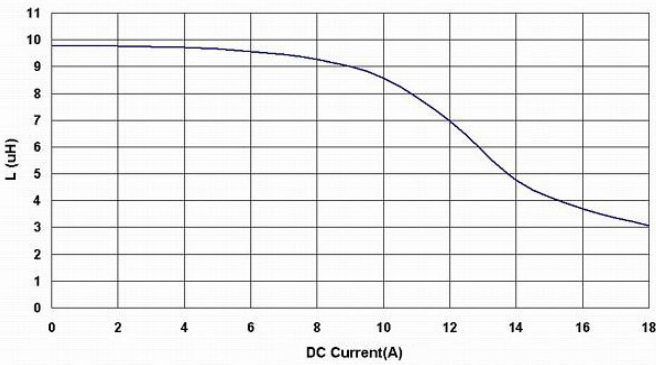

BPSC00131380120□00

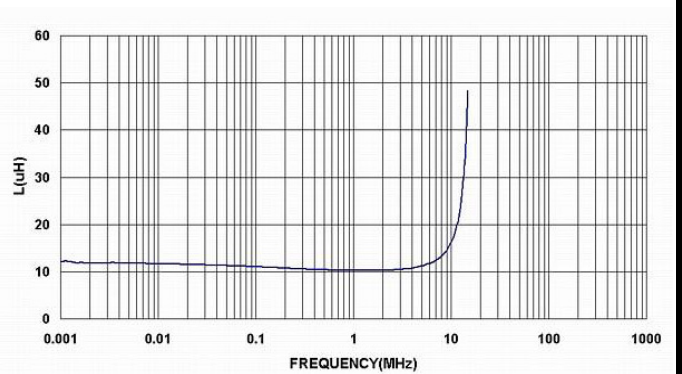
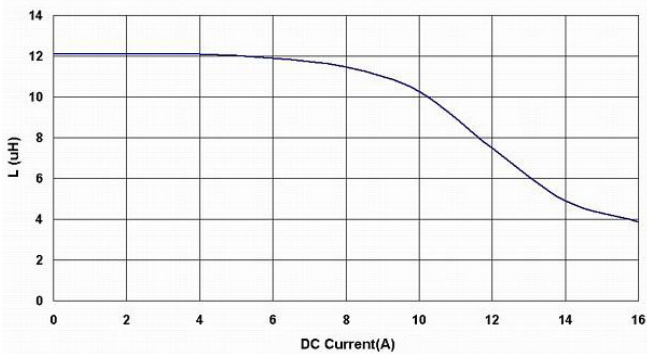

BPSC00131380150□00

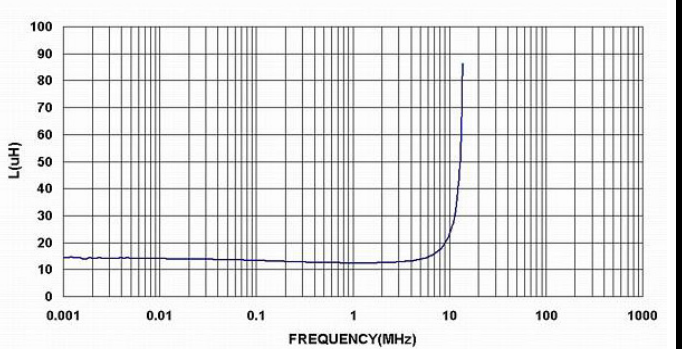
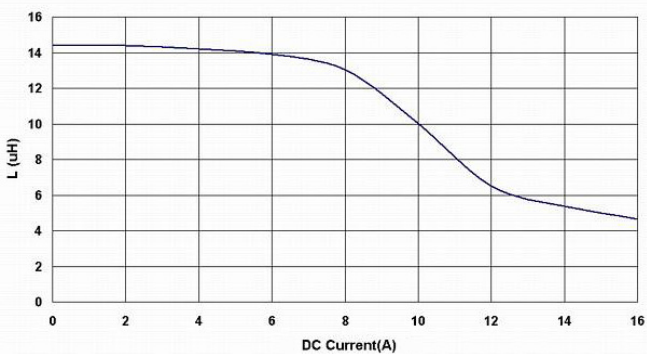

BPSC00131380 Series Specification

13 Graph:

BPSC00131380180□00

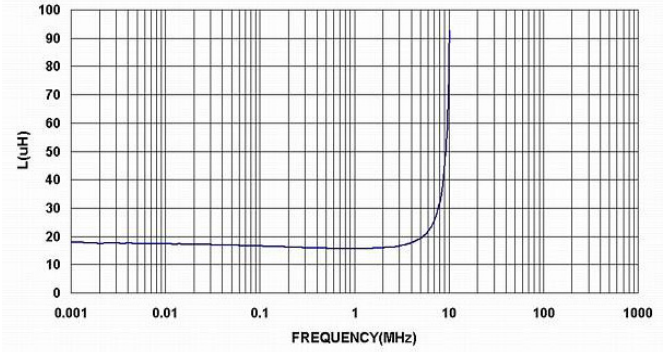
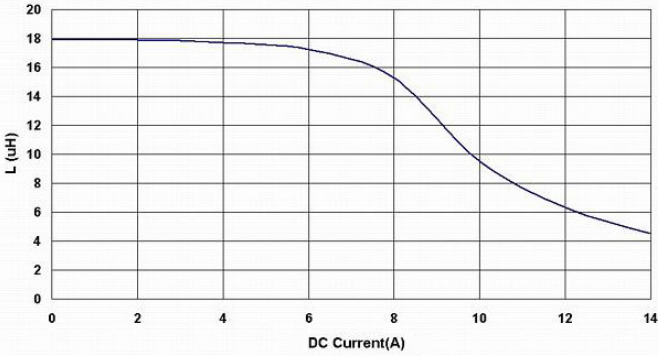

BPSC00131380220□00

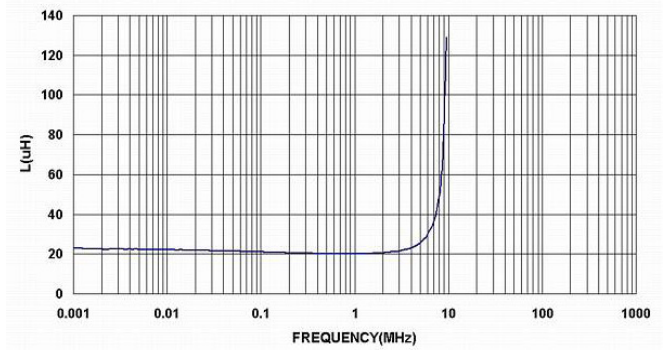
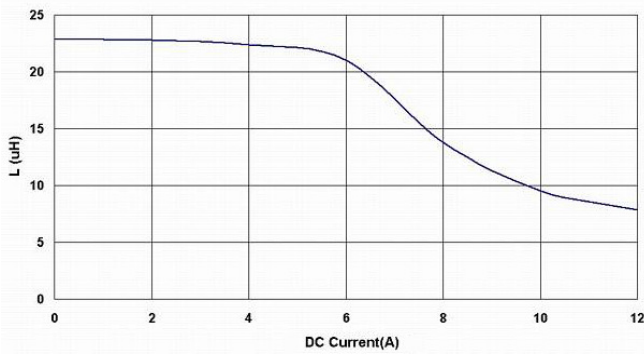

BPSC00131380270□00

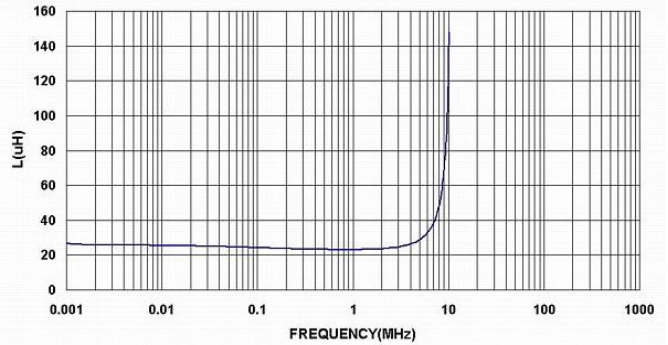
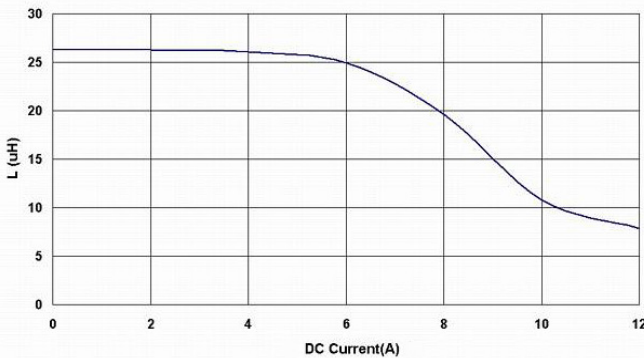

BPSC00131380330□00

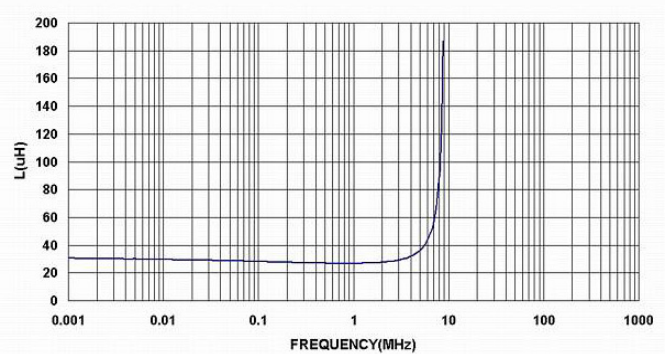
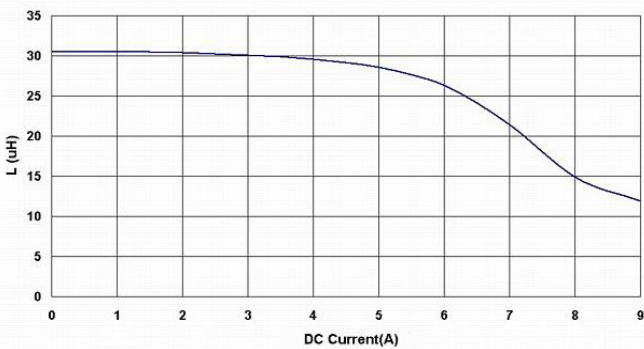

BPSC00131380 Series Specification

13 Graph:

BPSC00131380390□00

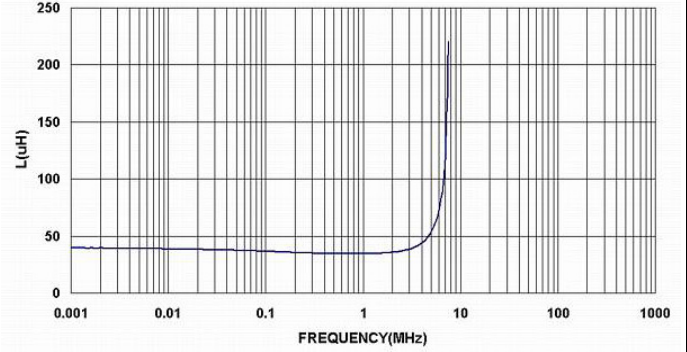
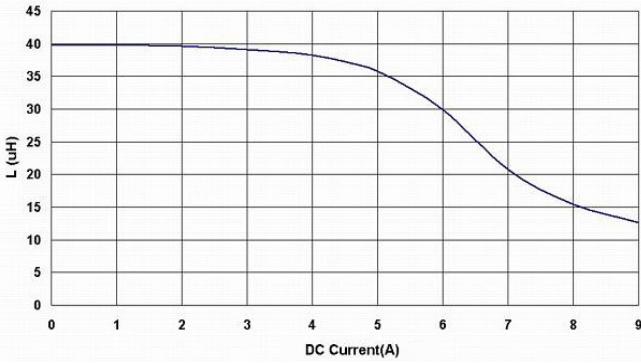

BPSC00131380470□00

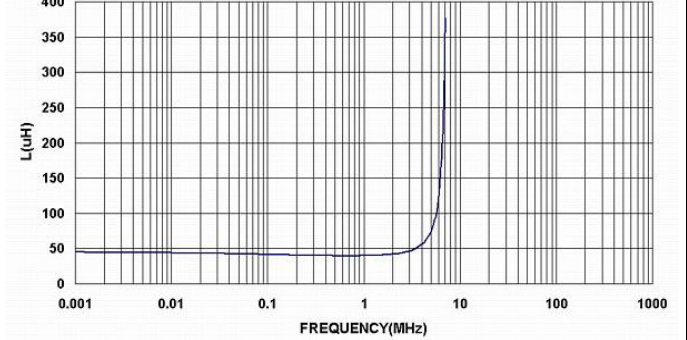
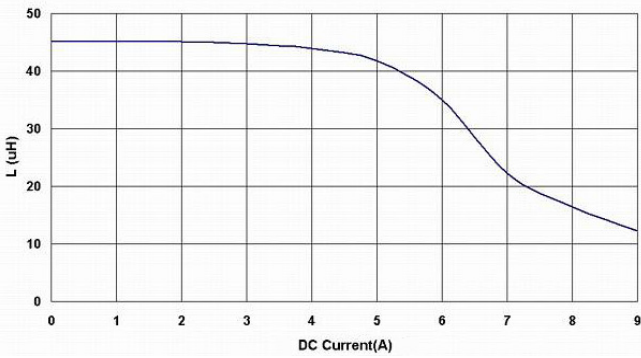

BPSC00131380560□00

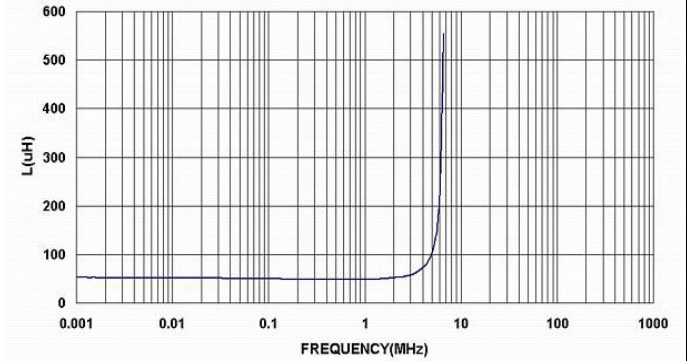
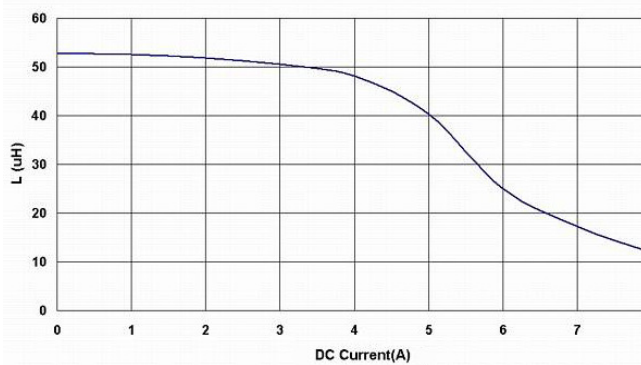

BPSC00131380680□00

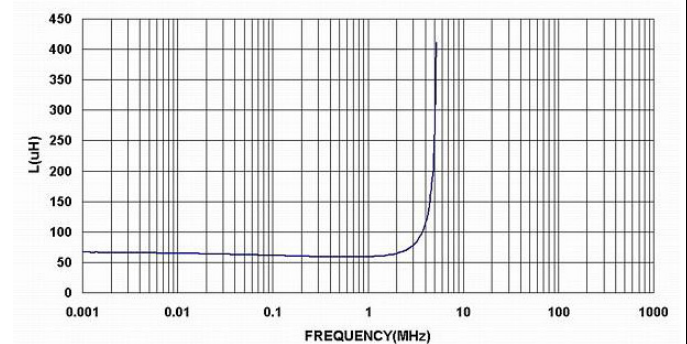
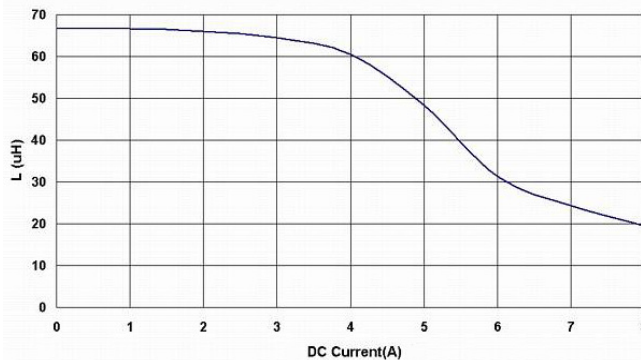

BPSC00131380 Series Specification

13 Graph:

BPSC00131380820□00

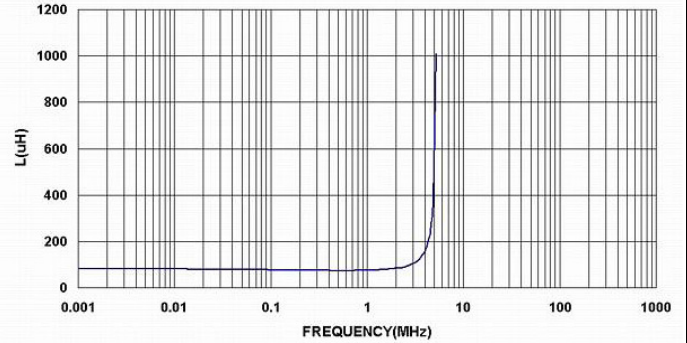

BPSC00131380101□00

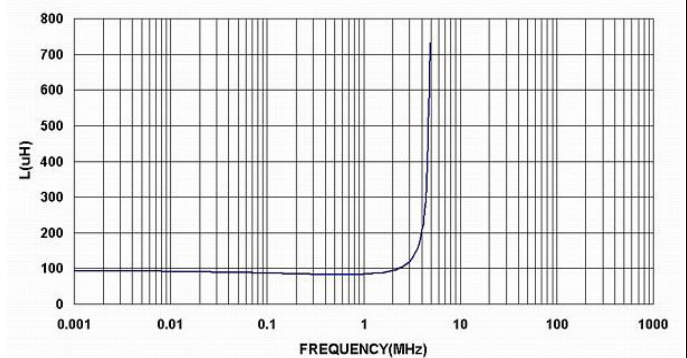
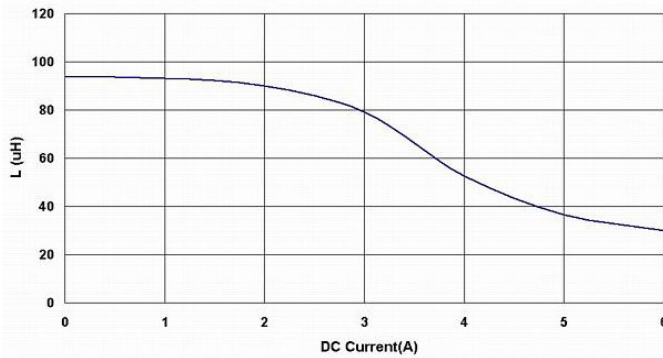

BPSC00131380121□00

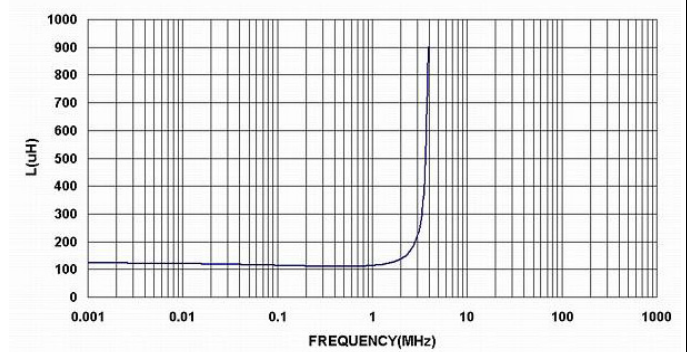
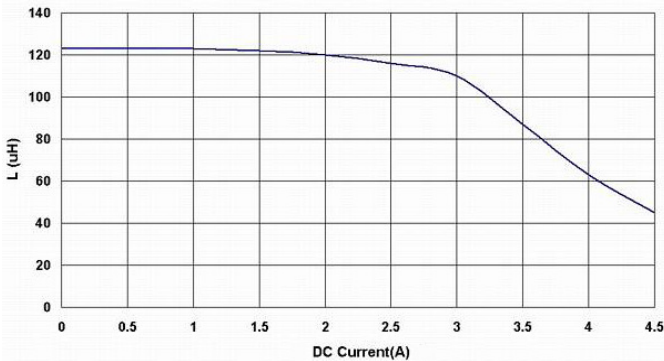

BPSC00131380151□00

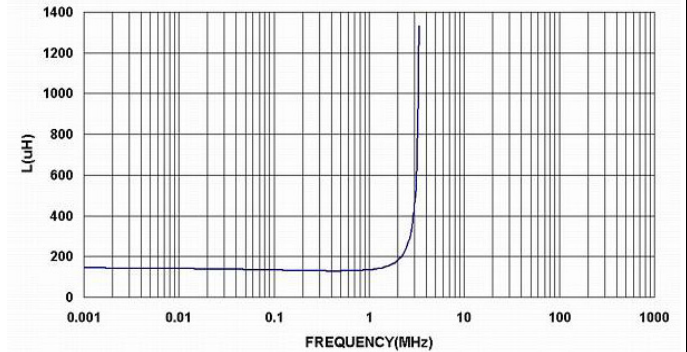

BPSC00131380 Series Specification

13 Graph:

BPSC00131380181□00

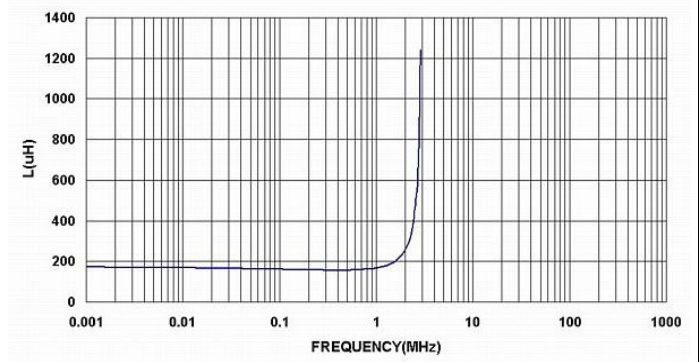
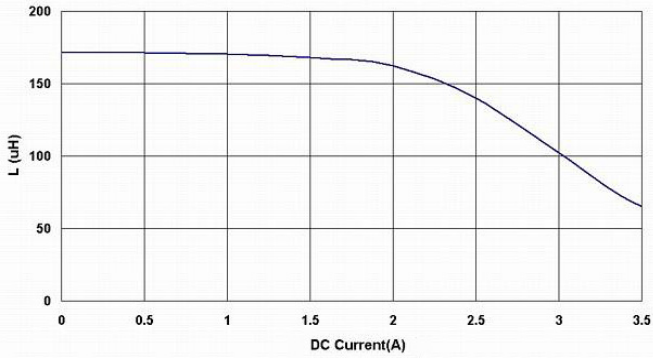

BPSC00131380221□00

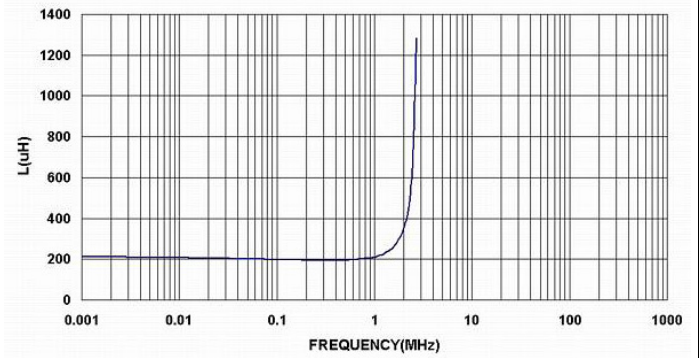
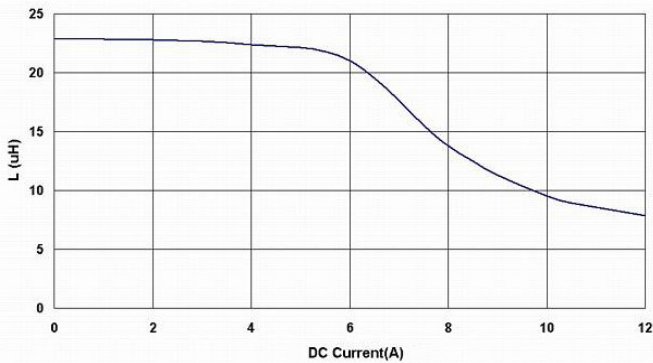

BPSC00131380271□00

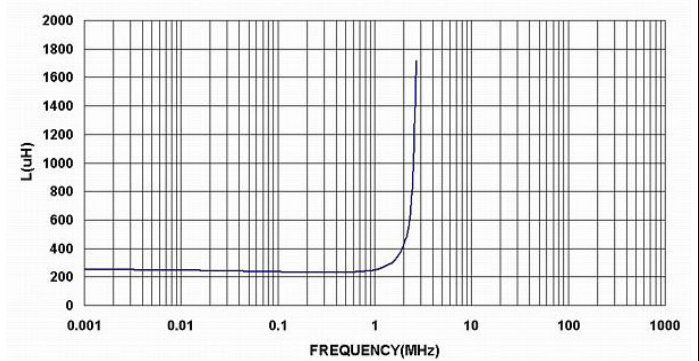
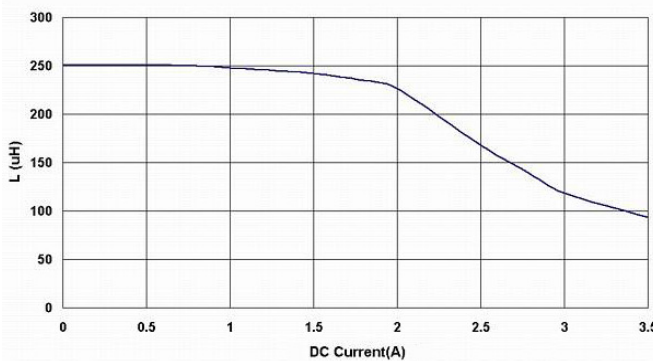

BPSC00131380331□00

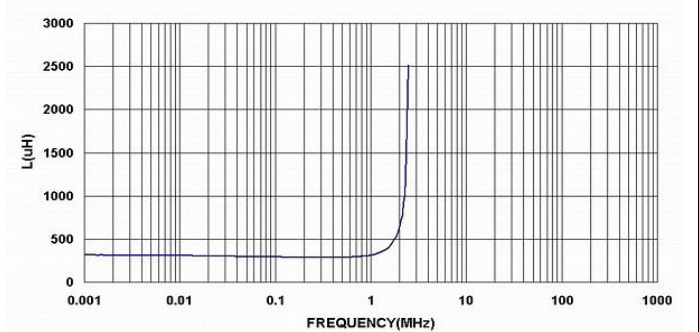
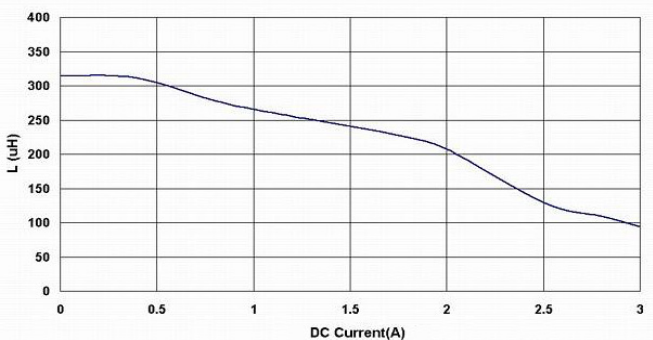

BPSC00131380 Series Specification

13 Graph:

BPSC00131380391□00

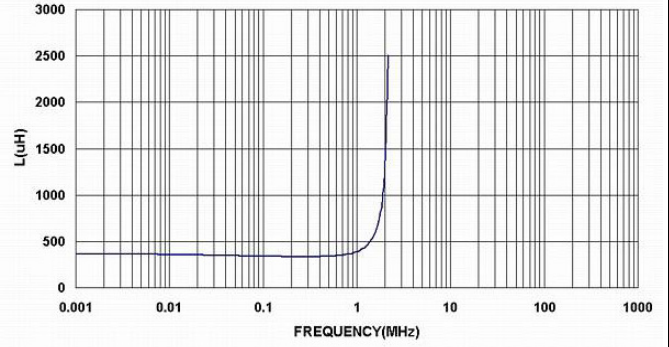
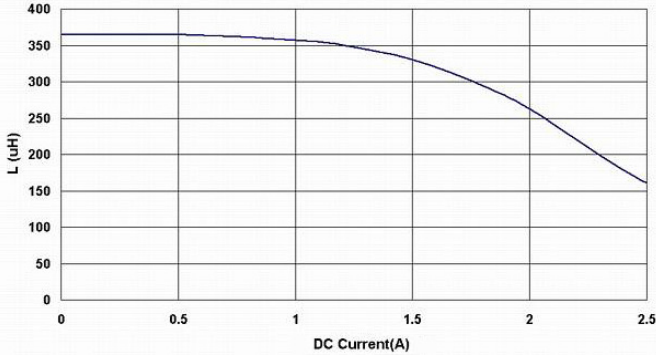

BPSC00131380471□00

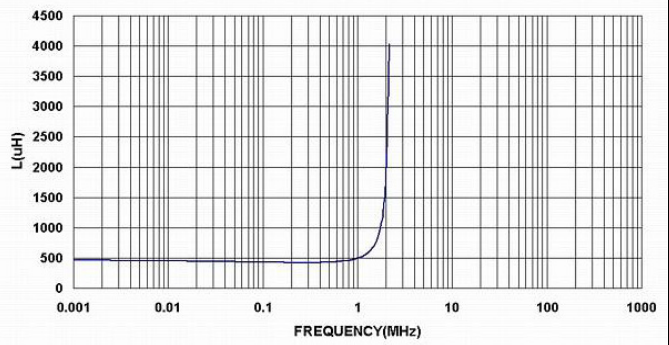
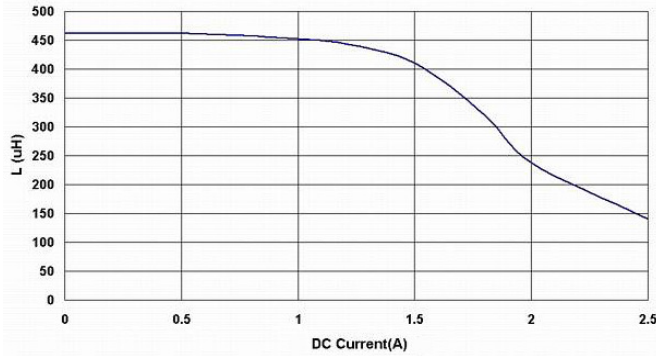

BPSC00131380561□00

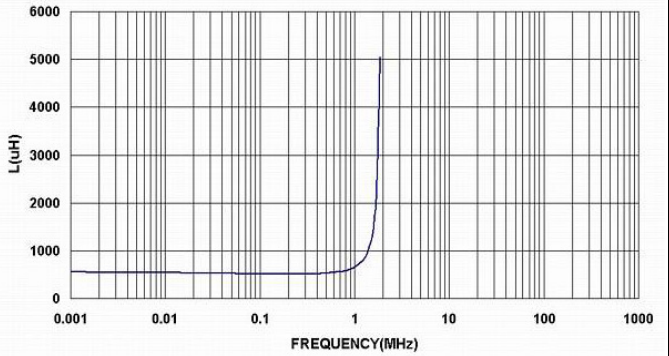
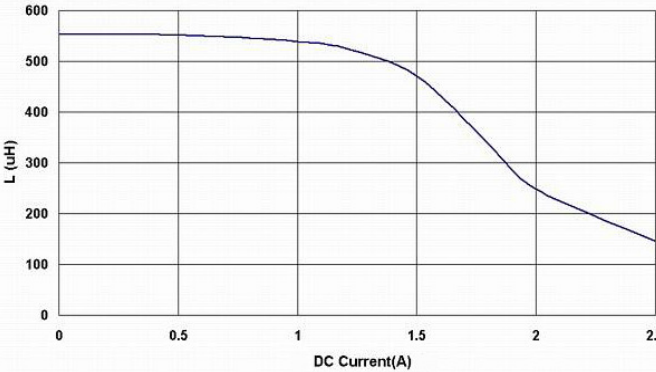

BPSC00131380681□00

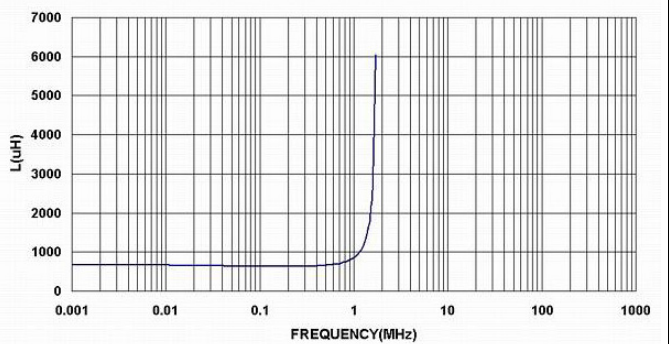
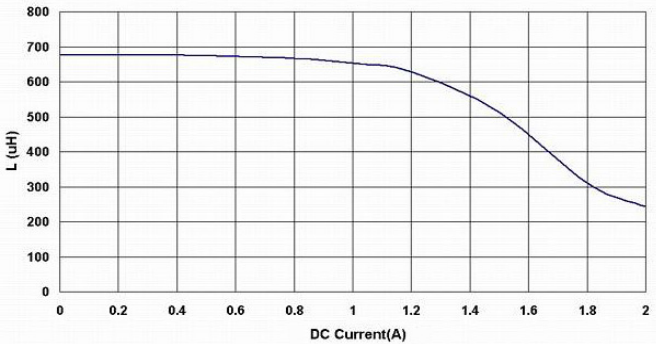

BPSC00131380 Series Specification

13 Graph:

BPSC00131380821□00

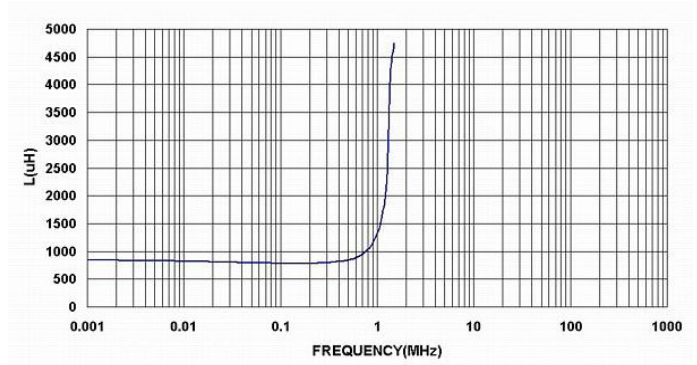
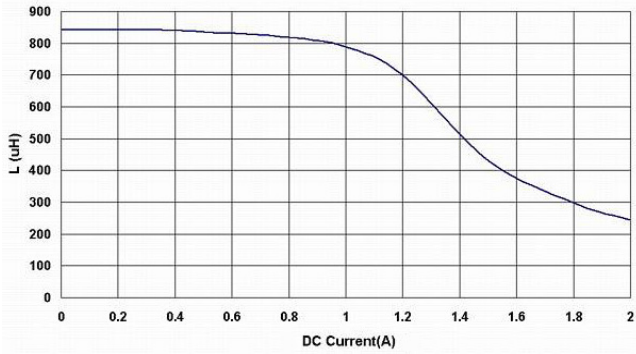

BPSC00131380102□00

