

RF Inductor



BWLS Series



Overview

Wire-wound RF inductors are electronic components designed to store energy in a magnetic field when electrical current passes through them. They are constructed by winding a conductive wire (usually copper or gold-plated) around a core material such as air, ceramic, or ferrite.

This configuration allows them to provide high inductance values with minimal power loss, especially at high frequencies.

Benefits

1. High Q-Factor (Quality Factor)
2. Ceramic body and wire wound construction provide high SRFs
3. Low DC resistance design
4. High Current Handling
5. Low inductance value

Applications

1. Industrial and Medical Equipmen: RFID systems and medical imaging equipment.
2. Data Centers
3. Networking
4. Base Station
5. Consumer Electronics
6. Security system

Product Information

Series	Size Code (JIS/EIA)	Inductance (nH)
BWLS	0603/0201	0.0047 ~ 560
	1005/0402	
	1608/0603	
	2012/0805	
	2520/1008	



BWLS00241715 Series Specification

1 Scope: This specification applies to Wire Wound Ferrite Chip Inductors

2 Part numbering:

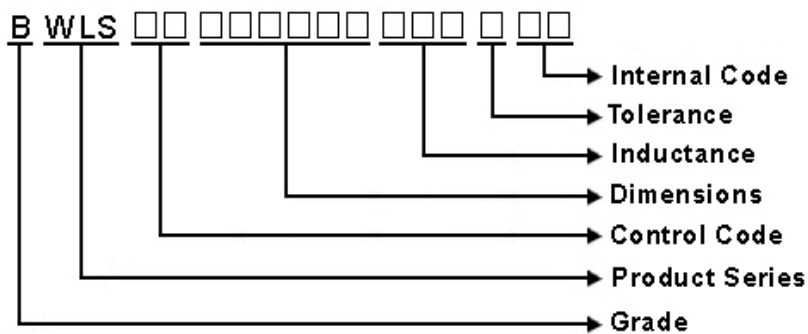

3 Rating:

Operating Temperature: - 40°C ~ 105°C
(Including self - temperature rise)

Storage Temperature: - 40°C ~ 105°C
(The storage temperature range is for after the assembly)

4 Marking:

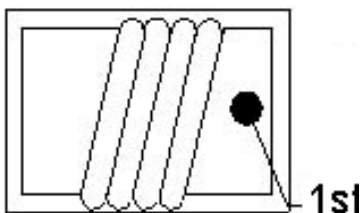

Marking: 1st → BLU

5 Standard Testing Condition

	Unless otherwise specified	In case of doubt
Temperature	Ordinary Temperature(15 to 35°C)	20 to 30°C
Humidity	Ordinary Humidity(25 to 85% RH)	50 to 80 %RH

BWLS00241715 Series Specification

6 Configuration and Dimensions and Unit Weight:

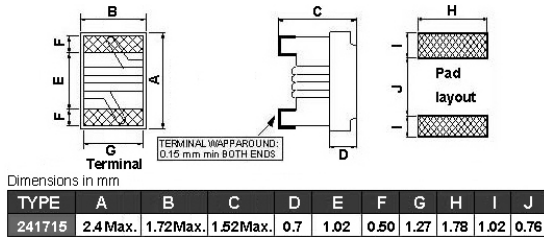

Net Weight (grams)

SIZE CODE	Net Weight (grams)
241715	0.0126 (typ.)

7 Electrical Characteristics:

Part No.	Inductance (uH)	L/Q Test Freq. (MHz)	Q Typ.	SRF (MHz)Min.	RDC (Ω)Max.	IDC (mA)	Tolerance (±%)	Color Code 1st
BWLS0024171578N□00	0.078	7.9/7.9	19	1440	0.06	2000	5,10	BLK
BWLS0024171590N□00	0.09	7.9/7.9	19	1200	0.07	2000	10	RED
BWLS00241715R11□00	0.11	7.9/7.9	19	1200	0.07	2000	5,10	BRN
BWLS00241715R47□00	0.47	7.9/7.9	19	480	0.4	800	5,10	RED
BWLS00241715R56□00	0.56	7.9/25.5	35	480	0.4	800	5,10	YEL
BWLS00241715R68□00	0.68	7.9/7.9	20	480	0.4	800	5,10	ORN
BWLS00241715R91□00	0.91	7.9/7.9	20	400	0.69	700	5,10	YEL
BWLS00241715R0□00	1	7.9/7.9	20	400	0.69	700	5,10	YEL
BWLS00241715R2□00	1.2	7.9/7.9	20	330	0.83	700	5,10	RED
BWLS00241715R5□00	1.5	7.9/7.9	20	330	0.83	700	5,10	GRN
BWLS00241715R8□00	1.8	7.9/7.9	20	300	1	650	5,10	BLU
BWLS00241715R2□00	2.2	7.9/7.9	20	250	1.1	650	5,10	VIO
BWLS00241715R7□00	2.7	7.9/7.9	23	200	1.25	650	5,10	GRY
BWLS00241715R3□00	3.3	7.9/7.9	23	160	1.45	650	5,10	WHT
BWLS00241715R9□00	3.9	7.9/7.9	23	90	1.5	600	5,10	BLK
BWLS00241715R7□00	4.7	7.9/7.9	20	70	1.6	530	5,10,20	BRN
BWLS00241715R6□00	5.6	7.9/7.9	20	65	1.7	500	5,10	RED
BWLS00241715R8□00	6.8	7.9/7.9	20	45	1.95	470	5,10	ORN
BWLS00241715R2□00	8.2	2.5/2.5	16	45	2.1	450	5,10	YEL
BWLS00241715100□00	10	2.5/2.5	16	40	2.4	400	5,10	GRN
BWLS00241715120□00	12	2.5/2.5	16	38	3.2	360	5,10	RED
BWLS00241715150□00	15	2.5/2.5	16	30	3.55	350	5,10	BLU
BWLS00241715180□00	18	2.5/2.5	16	25	4.9	300	5,10	ORN
BWLS00241715220□00	22	2.5/2.5	16	20	5.45	270	5,10	VIO
BWLS00241715270□00	27	2.5/2.5	16	19	7.8	240	5,10	GRY

NOTE: □-tolerance J=±5% / K=±10% / M=±20%

1. Operating temperature range -40°C ~ 105°C (Including self - temperature rise)
2. L/Q Test OSC @200mV.
3. IDC for Inductance drop 10% from its value without current.

BWLS00241715 Series Specification

Part No.	Inductance (uH)	L/Q Test Freq. (MHz)	Q Typ.	SRF (MHz)Min.	RDC (Ω)Max.	IDC (mA)	Tolerance (±%)	Color Code 1st
BWLS00241715330□00	33	2.5/2.5	16	16	9.5	210	5,10	WHT
BWLS00241715470□00	47	2.5/2.5	16	15	14.5	180	5,10,20	BRN

NOTE: □-tolerance J=±5% / K=±10% / M=±20%

1. Operating temperature range – 40°C ~ 105°C (Including self - temperature rise)
2. L/Q Test OSC @200mV.
3. IDC for Inductance drop 10% from its value without current.

BWLS00241715 Series Specification

8 BWLS00241715 Series

8.1 Construction:

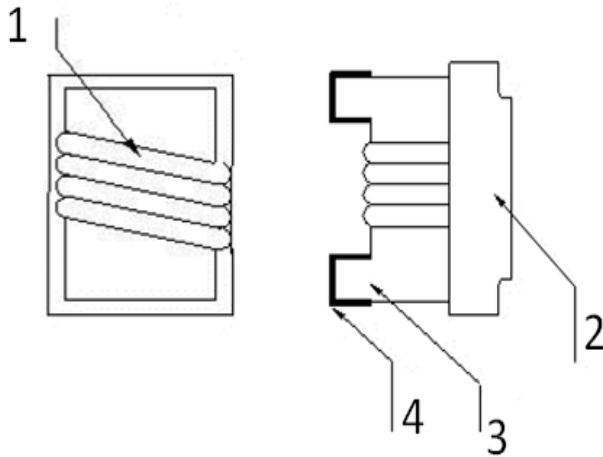

8.2 Material List:

NO	PART	MATERIAL
1	WIRE	Grade 180
2	EPOXY	UV GLUE
3	CORE	FERRITE CORE
4	TERMINAL	Ag/Cu/Ni/Sn

BWLS00241715 Series Specification

9 Reliability Of Ferrite Wire Wound Chip Inductor/FERRITE SERIES

1-1.Environmental Performance

No	Item	Specification	Test Method		
1-1-1	Temperature Cycle	Appearance: No Damage Inductance: within $\pm 10\%$ of initial value Q change: within $\pm 30\%$ of initial value	One cycle:		
			Step	Temperature ($^{\circ}\text{C}$)	Time (min)
			1	-40 ± 3	30
			2	25 ± 2	3
			3	105 ± 3	30
4	25 ± 2	3			
1-1-2	High Temperature Resistance	There should be no evidence of short or open circle	Total: 5 cycles Measured After Exposure in The Room Condition For 1hrs		
1-1-3	Low Temperature Resistance		Temperature: $105\pm 3^{\circ}\text{C}$ Time: 1000Hrs Measured After Exposure In The Room Condition For 1Hrs		
1-1-4	Humidity Load Life		Temperature: $-40\pm 3^{\circ}\text{C}$ Time: 1000Hrs Measured After Exposure In The Room Condition For 1Hrs		
			Temperature: $40\pm 2^{\circ}\text{C}$ Relative Humidity: 90~95% Load: Allowed DC Current Time: 96Hrs		

1-2.Mechanical Performance

No	Item	Specification	Test Method
1-2-1	Resistance TO Soldering Heat	Appearance: No Damage	1. The device should be reflow soldered on PCB (peak $260^{\circ}\text{C} \pm 5^{\circ}\text{C}$ for 10 seconds) 2. Solder Composition: Sn/Ag3.0/Cu0.5 3. Test time: 6 minutes
1-2-2	Solder ability	The Electrodes Shall Be At Least 95% Covered With New Solder Coating	1. Pre-Heating: 150°C , 1min. 2. Solder Composition: Sn/Ag3.0/Cu0.5 3. Solder Temperature: $245\pm 5^{\circ}\text{C}$. 4. Immersion Time: 4 ± 1 sec.
1-2-3	Component Adhesion (Push Test)	1 Lbs. For 0402 1 Lbs. For 0603 2 Lbs. For 201614 2 Lbs. For 0805 4 Lbs. For The Rest	The device should be reflow soldered ($245\pm 5^{\circ}\text{C}$ For 10 seconds) to a tinned copper substrate. A force gauge should be applied to the side of the component. The device must withstand a minimum force of 1or2or4 pounds without a failure of the termination attached to component

BWLS00241715 Series Specification

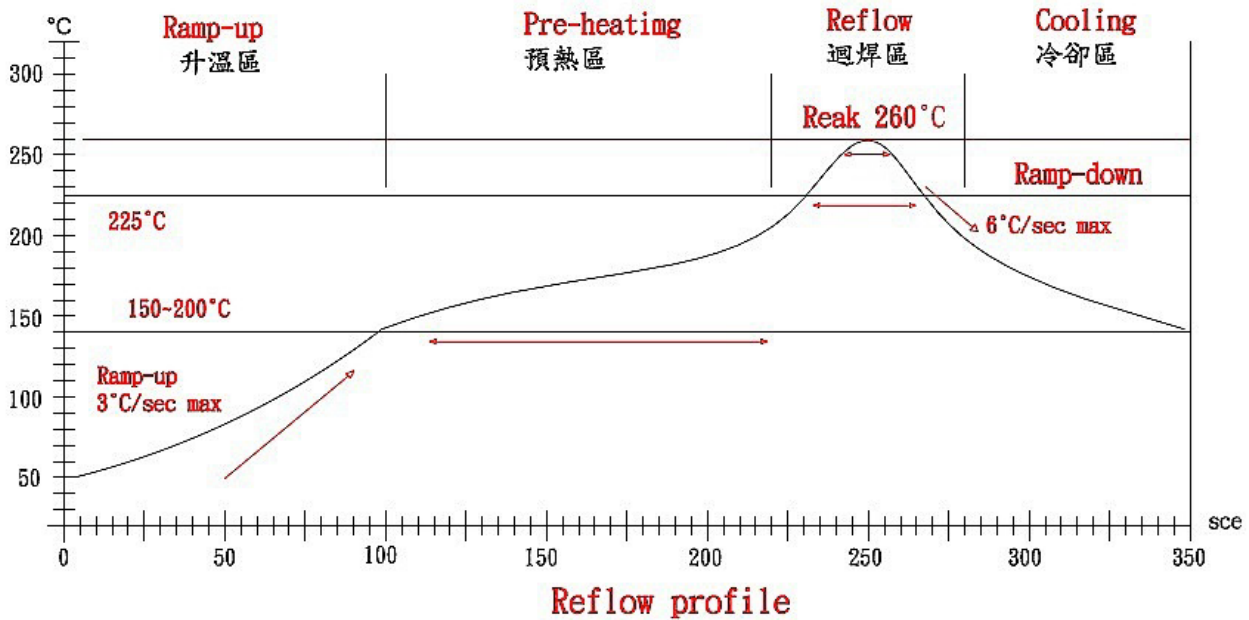

Lead-Free(LF)標準溫度分析範圍

Refer to J-STD-020C

管制項目 Item.	升温區 Ramp-up	預熱區 Pre-heating	迴焊區 Reflow	Peak Temp	冷卻區 Cooling
溫度範圍 Temp.scope	R.T ~ 150°C	150°C ~ 200°C	Above 217°C	260±5°C	Peak Temp.~150°C
標準時間 Time spec.	-	60 ~ 180 sec	60 ~ 150 sec	20 ~ 40 sec	-
實際時間 Time result	-	75 ~ 100 sec	90 ~ 120 sec	20 ~ 35 sec	-

NOTE:

- 1.Re-flow possible times : within 3 times
- 2.Nitrogen adopted is recommends while in re-flow
- 3.Products can only be soldered with reflow

BWLS00241715 Series Specification

10 Packaging:

10.1 Packaging -Cover Tape

The force for tearing off cover tape is 10 to 100 grams in the arrow direction.

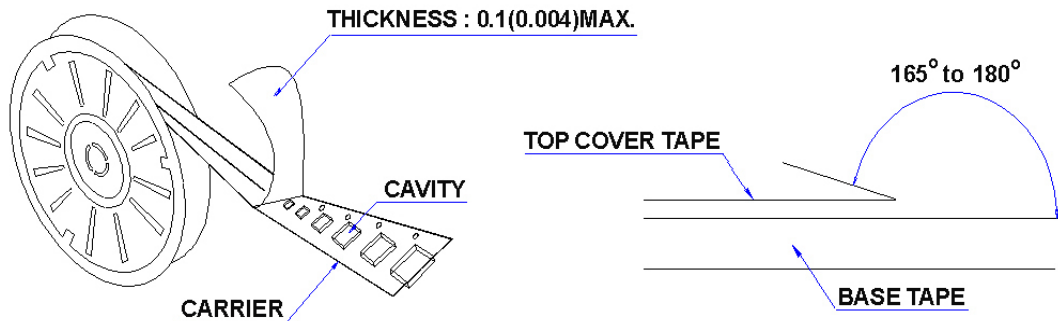

10.2 Packaging Quantity

TYPE	PCS/REEL
241715	2000

10.3 Reel Dimensions

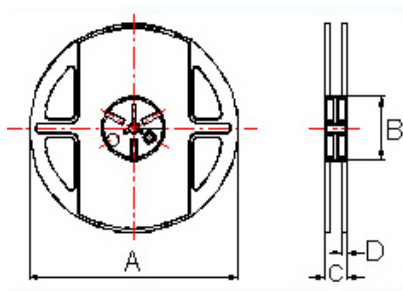

Dimensions in mm

TYPE	A	B	C	D
241715	178±1	60±0.5	12±0.5	1.5±0.5

BWLS00241715 Series Specification

10 Packaging:

10.4 Tape Dimensions in mm

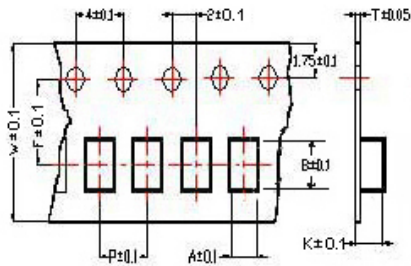

Tape Material

Carrier tape : Polycarbonate

Cover tape : Polyethylene

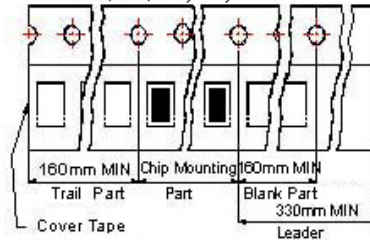

TYPE	A	B	T	W	P	F	K
241715	1.60	2.42	0.22	8.0	4	3.5	1.45

11 Recommended Land Pattern:

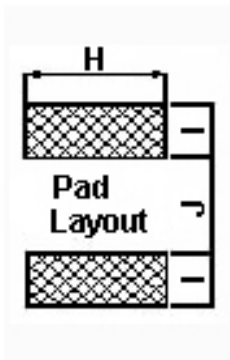

Dimensions in mm

TYPE	H(In/mm)	I(In/mm)	J(In/mm)
241715	0.07/1.78	0.04/1.02	0.03/0.76

12 Note:

- Please make sure that your product has been evaluated and confirmed against your specifications when our product is mounted to your product.
- Do not knock nor drop.
- All the items and parameters in this product specification have been prescribed on the premise that our product is used for the purpose, under the condition and in the environment agreed upon between you and us. You are requested not to use our product deviating from such agreement.
- The storage period is less than 12 months. Be sure to follow the storage conditions (Temperature: 5 to 40°C, Humidity: 10 to 75% RH or less).
If the storage period elapses, the soldering of the terminal electrodes may deteriorate.
- Do not use or store in locations where there are conditions such as gas corrosion (salt, acid, alkali, etc.).
- The moisture sensitivity level (MSL) of products is classified as level 1.

BWLS00241715 Series Specification

13 Graph:

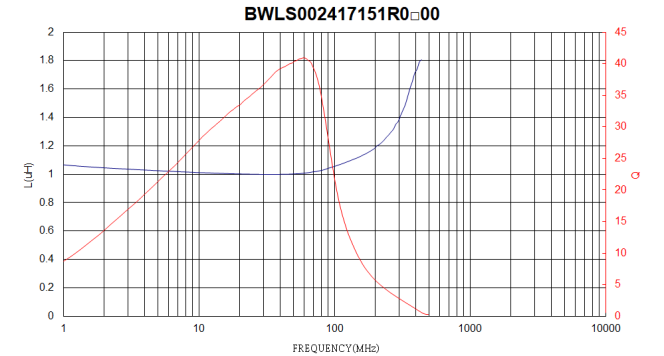
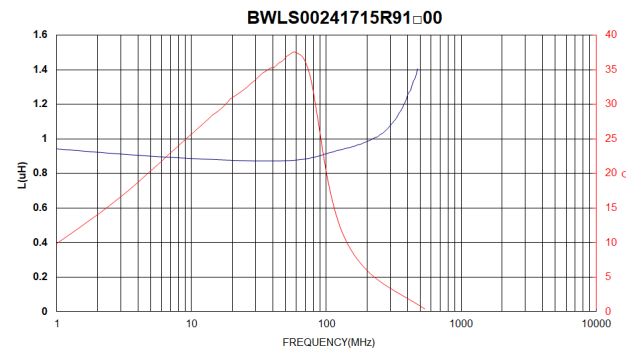
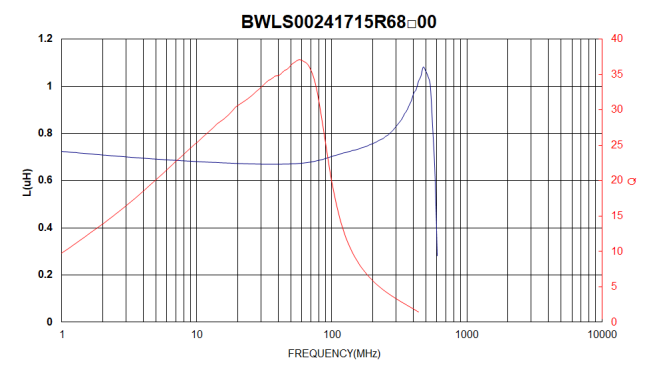
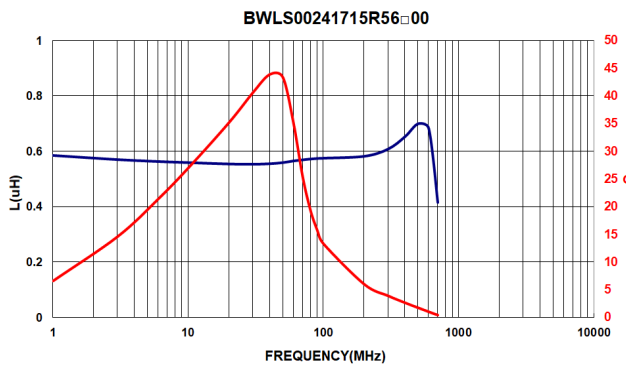
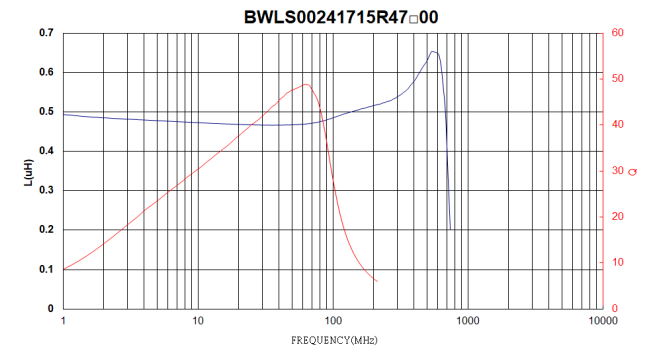
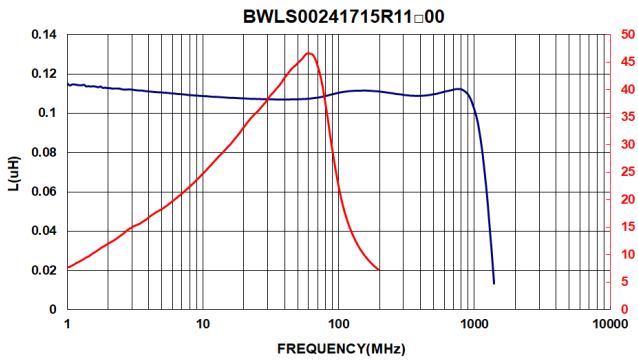
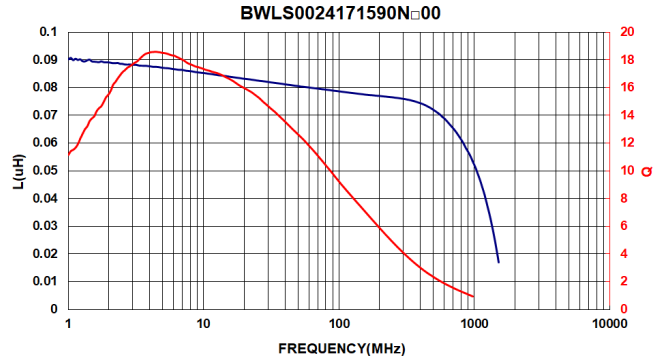
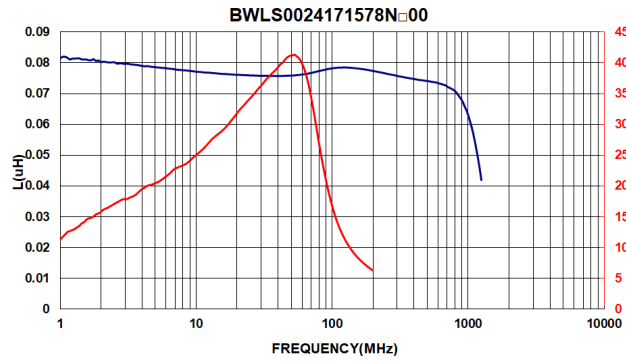

BWLS00241715 Series Specification

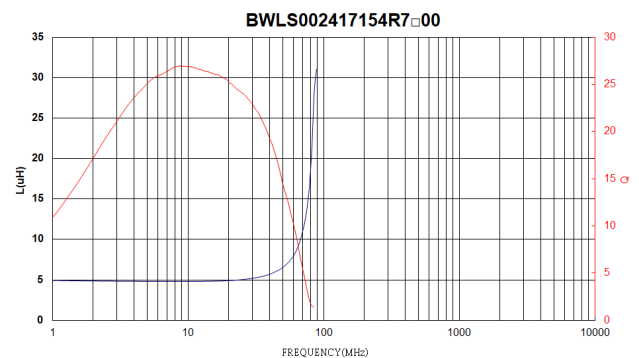
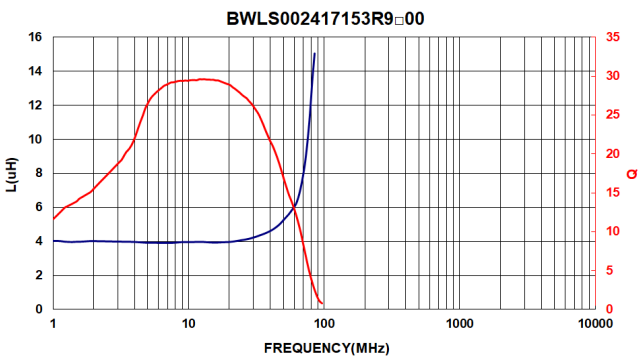
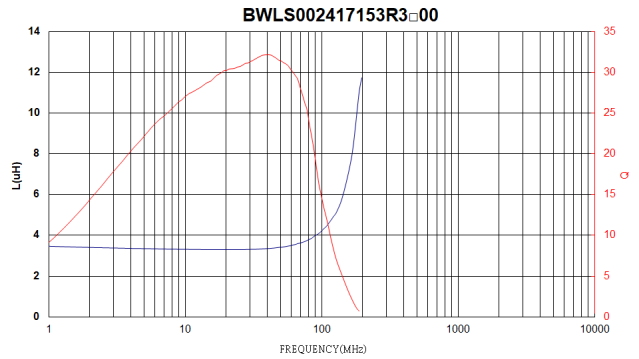
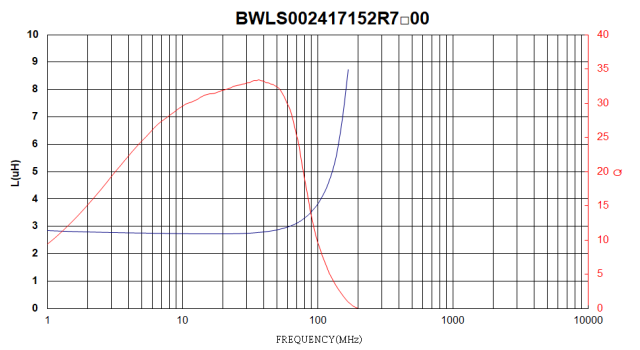
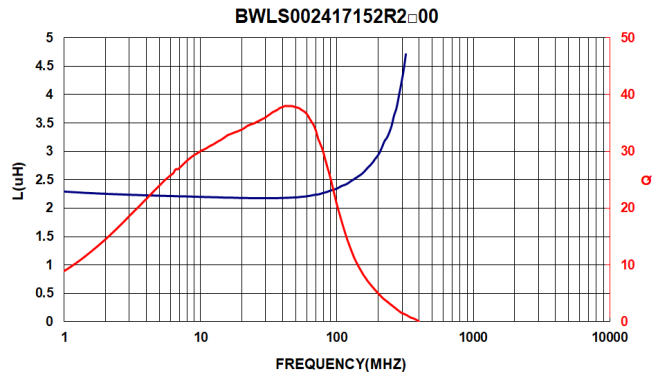
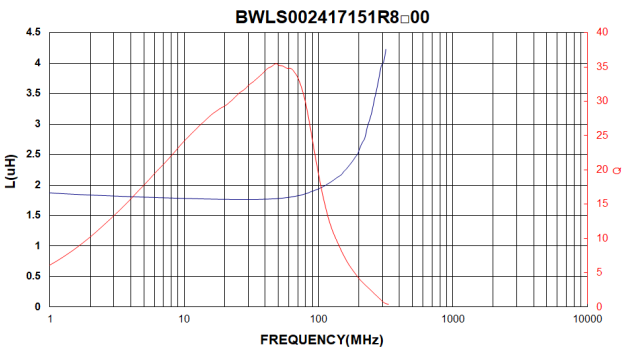
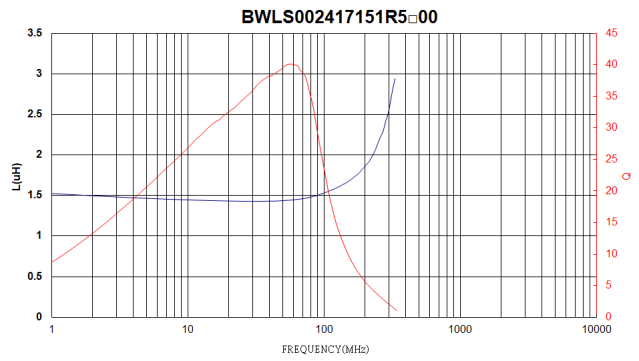
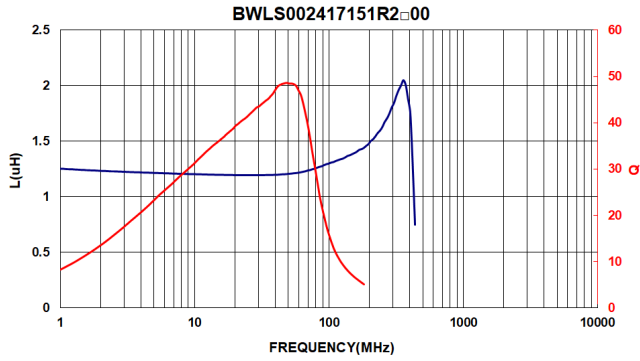

BWLS00241715 Series Specification

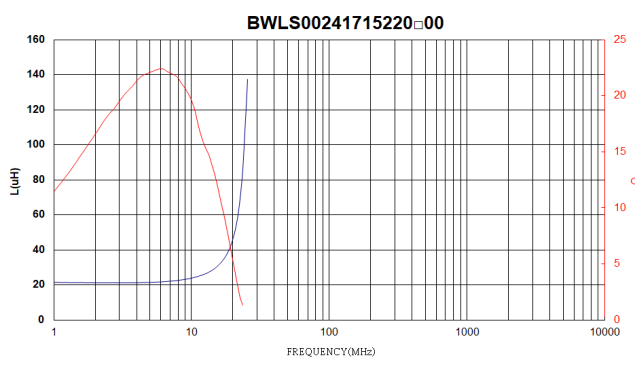
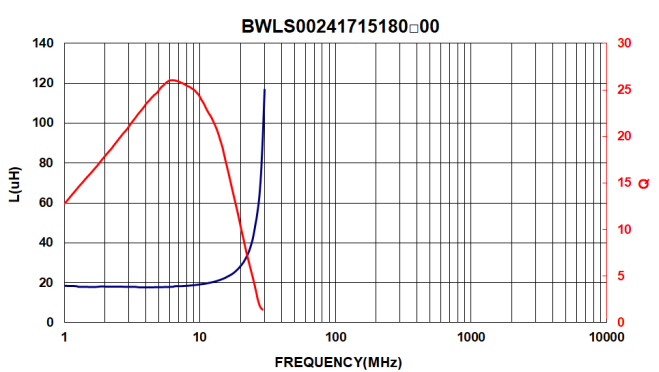
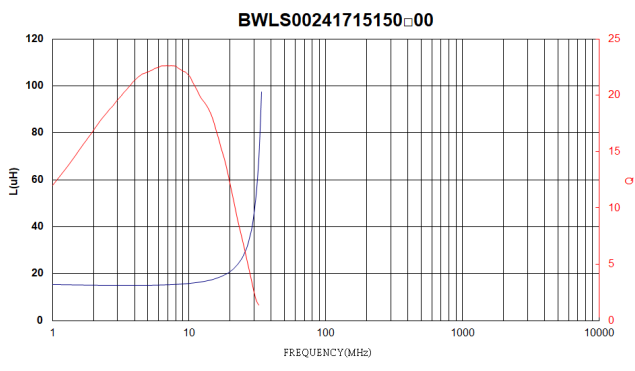
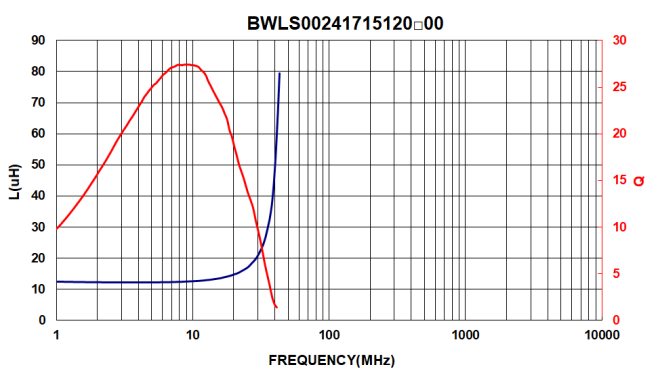
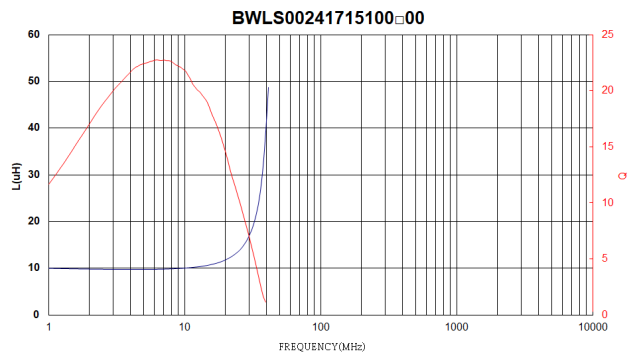
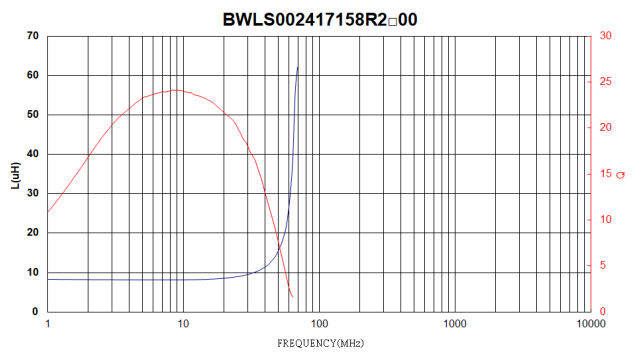
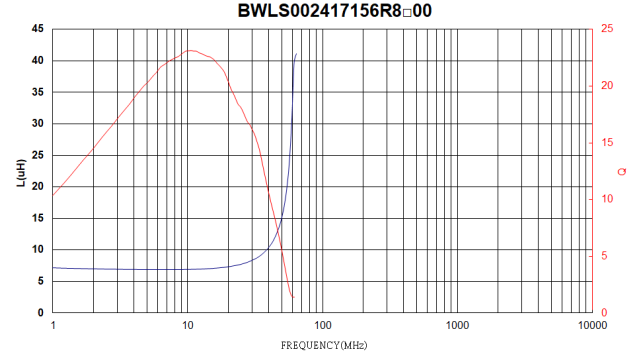
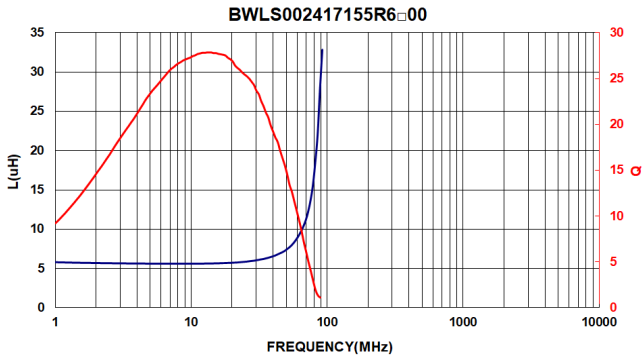

BWLS00241715 Series Specification

