

1.5kW Fan cooled

AC-DC power supplies

The HPA1K5 series offers users both output voltage and output current programming, via voltage, I²C PMBus, RS485 and CANopen in a very high efficiency, high power density 1.5kW chassis mount package. Options are available for RS232 or UART.

Measuring just 279.4 x 106.6 x 41.6mm, the HPA1K5 also features active current sharing, remote on/off, remote sense and a power OK signal. The 5V/2A standby output is available whenever the mains supply is present.

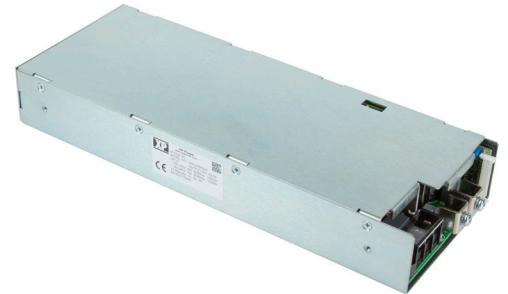

Features

- ▶ Programmable output voltage (0-105%)
- ▶ Programmable output current (0-110%)
- ▶ High efficiency - up to 93%
- ▶ ITE and medical approvals
- ▶ Parallel operation
- ▶ Analog and digital interfaces
- ▶ Multiple digital protocols - PMBus, CANopen, MODBUS and SCPI
- ▶ Fully featured signals and controls
- ▶ Graphical user interface (GUI)
- ▶ 5V/2A standby supply
- ▶ SEMI F47 compliant
- ▶ 3 year warranty

Applications

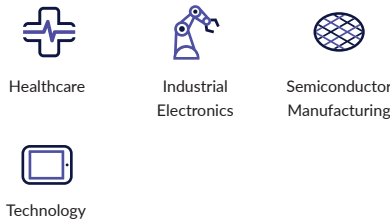

Dimensions

279.4 x 106.6 x 41.6 mm
(11.0" x 4.20" x 1.64" in)

Documentation

For further information click the link or scan the code

→ xppower.com



Models & ratings

Model number ⁽¹⁾	Max output power	Output voltage V1			Output current		Efficiency ⁽²⁾
		Minimum	Nominal	Maximum	Minimum	Maximum	
HPA1K5PS24	1.5kW	0VDC	24VDC	25.2VDC	0.0A	62.50A	91%
HPA1K5PS36	1.5kW	0VDC	36VDC	37.8VDC	0.0A	41.70A	92%
HPA1K5PS48	1.5kW	0VDC	48VDC	50.4VDC	0.0A	31.25A	93%
HPA1K5PS60	1.5kW	0VDC	60VDC	63.0VDC	0.0A	25.00A	92%

Notes:

1. Standard models include PMBus, CANopen and RS485 interfaces. RS485 default is full duplex. RS485 half duplex can be configured via I²C or factory configured on request. To replace RS485 with RS232 or UART, contact sales.

2. Measured with 230VAC input and full load.

3. USB interface available to enable RS485 and RS232 communication with GUI. Part number XP PS MANAGER INT.

Input

Characteristic	Minimum	Typical	Maximum	Units	Notes & conditions
Input voltage (see application notes)	180		264	VAC	1.5kW
	100		180		1.4kW max
	90		100		1.2kW max
Input frequency	47		63	Hz	
Power factor		0.96			Complies with EN61000-3-2 for Class A
Input current			16	A	100VAC, 1400W
Inrush current			40	A	264VAC, 25°C cold start
Earth leakage current			450	μA	264VAC, 60Hz
Input protection	F20A / 250V fuse fitted in line and neutral				

Output

Characteristic	Minimum	Typical	Maximum	Units	Notes & conditions
Output voltage	0		63	VDC	See Models and Ratings table
Output set tolerance		±0.5		%	Nominal voltage irrespective of set voltage
+5V standby tolerance		±3		%	5V/2A Standby
Output voltage program	0		105	%	Of nominal, slew rate <40ms 10-105% & 105-10%. Max frequency of voltage program is 0.5 Hz 0-5% load, 0.67Hz 5-10% load, 1Hz 10-20% load, 3 Hz 20-100% load
Output voltage adjust	±10			%	Of set output via potentiometer 105% of nominal max.
Output current program	0		110	%	Of nominal
Minimum load	0			A	No minimum load required
Start up delay		1.3	2	s	Under all load and line conditions
Start up rise time			40	ms	
Hold up time	10	14		ms	230VAC at 1.5kW and 25°C
	10	17			100VAC at 1.4kW and 25°C
Line regulation			±0.5	%	Of nominal voltage
			±0.5		5V Standby
Load regulation			1	%	0-100% or 100-0% load
			2		5V Standby
Transient response			3	%	Deviation with a 50-75-50% load change. Output returns to within 1% in less than 500μs
Ripple & noise			1/2.5	%	Of nominal voltage/5V Standby. Measured with 20MHz bandwidth limited oscilloscope 0-50°C
Overshoot			5	%	Turn on & turn off
Overvoltage protection	110		120	%	Of nominal voltage, latching. Cycle AC to reset. No protection for 5V Standby
Overtemperature protection	Auto resetting thermal protection				
Overload protection			±3	% of max load	Set current limit point. Constant current characteristics. Max current limit is 108/112% ±3% (24V/48V models) of maximum rated current. For low line (80-115VAC), constant power characteristic set at 1.4kW until current limit point is reached. 5V Standby: <5A max
Temperature coefficient			0.03	%/°C	Of max load
Short circuit protection	Constant current characteristics. 5V Standby: Foldback characteristic < 5A max				
Remote sense	Compensates for 1% max of nominal voltage per lead, 2% of total nominal voltage drop.				

General

Characteristic	Minimum	Typical	Maximum	Units	Notes & conditions
Efficiency		92		%	230VAC, 1.5kW, 5V Standby at full load
Isolation: Input to output	4000			VDC	2 x MOPP
Input to ground	2500			VDC	1 x MOPP
Output to ground	500			VDC	
Switching frequency	60	65	70	kHz	Fixed frequency PFC
	40		250	kHz	Variable frequency main converter
Power density			50.2 (822)	W/cm ³ (W/in ³)	
Signals and controls	V Program, I Program, AC OK, DC OK, Fan Fail/Temperature Warning, Sync, PMBus, Inhibit, Current Share				
MTBF		580		khrs	Telecordia 332, +25°C
Weight		1900 (4.2)		g (lb)	

Environmental

Characteristic	Minimum	Typical	Maximum	Units	Notes & conditions
Operating temperature	-20		+70	°C	Derate linearly from 50°C to 50% rated power at +70°C
Storage temperature	-40		+85	°C	
Cooling	Force-cooled with intelligent fan speed control				
Humidity	5		95	%RH	Non-condensing
Operating altitude			4000	m	Medical
			5000		IT
Shock	±3 x 30g shocks in each plane, total 18 shocks. 30g = 11ms (±0.5ms) half sine. Conforms to EN60068-2-27 & EN60068-2-47				
Vibration	Single axis 10-500Hz at 2g sweep and endurance at resonance in all 3 planes. Conforms to EN60068-2-6				

Signals & controls

	Function
V program ⁽¹⁾⁽²⁾	0V to 5V signal will program Vout from 0-105%. VProg accuracy ±3% of nominal output voltage. When left open, supply will go into its default operating mode
I program ⁽¹⁾⁽²⁾	0V to 5V signal will program the current limit from 0-110%. When this signal is left open, supply will go into its default operating mode. IProg accuracy ±3% of maximum rating
AC OK	LOW = Input Voltage is within operating range, HIGH = Input Voltage is outside of operating range or there is a loss of phase. Uncommitted opto-transistor, 2ms warning time
DC OK	When the supply is used as a variable output supply, this signal is disabled. When the supply is programmed as a fixed output supply, LOW = Vout > 95% of Vnominal. This level is programmable by the user through the PMBus. Uncommitted opto-transistor
Fan fail/Temp warning	High = Fan FAIL and/or overtemperature, Low = Fan OK and temperature OK (3.3V Logic), unit switches off 10 s after Fan Fail/Temp Warning alarm, auto recovery. XP Power GUI available for download, contact sales
Sync.	Connect parallel units to synchronise output turn on
PMBus, CANopen and RS485 Optional: RS485 can be replaced with RS232 or UART	The interface specification is detailed in a separate document "HPA1K5 Communication, Control and Status Specification". XP GUI available for download, contact sales. Vout monitor accuracy is ±1% of nominal voltage, Vout setting accuracy is ±1% of nominal voltage, Iout monitor accuracy is ±3% of full load, Iout setting accuracy is ±3% of full load
Current share	Connecting pin 23 on one unit to pin 23 on a like voltage unit will force the current to be shared. Up to 5 units can be paralleled. Current share accuracy ±3% of full system load
Inhibit	Uncommitted opto diode. See Signals & Controls

(1) In analog mode, the default Vout and Iout settings are 0% when open circuit.

(2) To activate analog mode, PMBus_EN (pin 24) must be pulled down to SGND. Default when open is digital programming.

EMC: emissions

Phenomenon	Standard	Test level	Notes & conditions
Conducted	EN55011/EN55032	Class B	Class A <80% nominal output voltage
Radiated	EN55011/EN55032	Class A	
Harmonic currents	EN61000-3-2	Class A	
Voltage flicker	EN61000-3-3		

EMC: immunity

Phenomenon	Standard	Test level	Criteria	Notes & conditions
ESD immunity	EN61000-4-2	4	A	±8kV contact / ±15kV air discharge
Radiated immunity	EN61000-4-3	3	A	
EFT/Burst	EN61000-4-4	3	A	
Surge	EN61000-4-5	Installation class 3	A	
Conducted	EN61000-4-6	3	A	
Magnetic field	EN61000-4-8	4	A	
Dips and interruptions	EN61000-4-11 (100VAC)	Dip 100%, 8.4ms	A	
		Dip 100%, 16.7ms	B	Criteria A derate to 1.1kW
		Dip 60%, 200ms	B	Criteria A derate to 315W
		Dip 30%, 500ms	A	
		Dip 20%, 5000ms	B	
		Int 100%, 5000ms	B	
	EN61000-4-11 (240VAC)	Dip 100%, 10ms	A	Criteria B >1440W
		Dip 100%, 20ms	B	Criteria A derate to 1kW
		Dip 60%, 200ms	B	Criteria A derate to 1.3W
		Dip 30%, 500ms	A	
		Dip 20%, 5000ms	A	
		Int 100%, 5000ms	B	
	EN60601-1-2 (100VAC)	Dip 100%, 10ms	A	Criteria B derate to >1.2kW
		Dip 100%, 20ms	B	Criteria A derate to 1kW
		Dip 60%, 100ms	B	Criteria A derate to 325W
		Dip 30%, 500ms	A	
		Int 100%, 5000ms	B	
	EN60601-1-2 (240VAC)	Dip 100%, 10ms	A	
		Dip 100%, 20ms	B	Criteria A derate to 1kW
		Dip 60%, 100ms	A	
Dip 30%, 500ms		A		
Int 100%, 5000ms		B		
SEMI F47-0706	>200VAC input		A	

Safety approvals

Certification	Safety standard	Notes & conditions
CB report	IEC62368-1 Ed 2	Information technology
	IEC60601-1 Ed 3 Including risk management	Medical
UL	UL62368-1, CSA 22.2 No.62368-1, UL60950-1	Information technology
	ANSI/AAMI ES60601-1:2005 & CSA C22.2, No.60601-1:08	Medical
EN	EN62368-1	Information technology
	EN60601-1/2006	Medical
CE	Meets all applicable directives	
UKCA	Meets all applicable legislation	
Equipment protection class	Class I	See safety agency conditions of acceptability for details
Isolation	Means of protection	Notes & conditions
Primary to secondary	2 x MOPP (Means of patient protection)	IEC60601-1 Ed 3
Primary to earth	1 x MOPP (Means of patient protection)	
Secondary to earth	N/A	

Application notes

Input derating

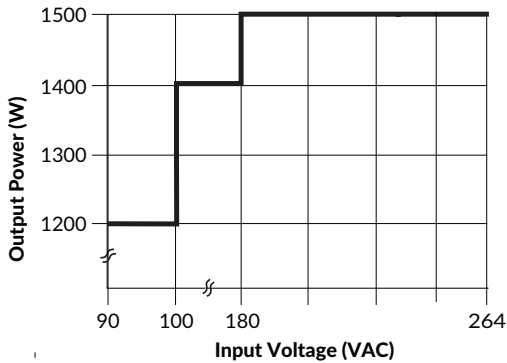

Output voltage programming

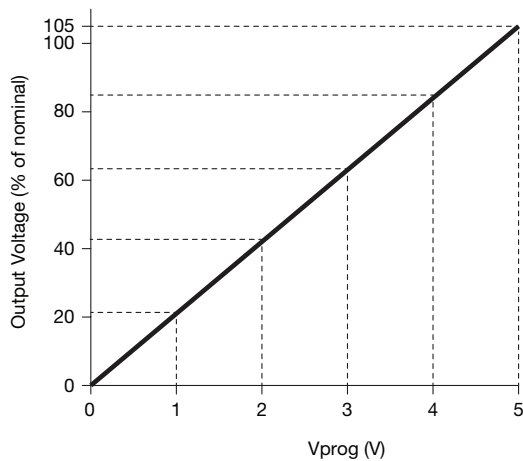

Output current programming

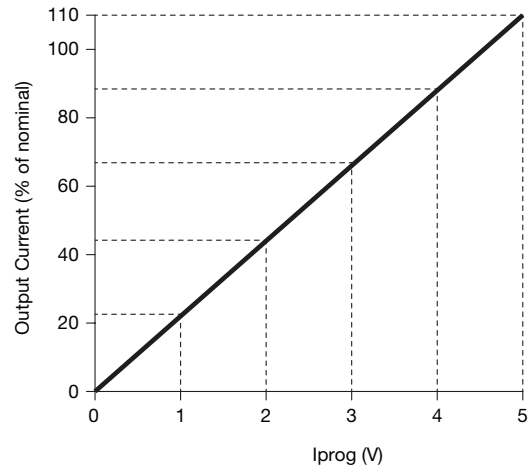

Signals & controls

Signal connections

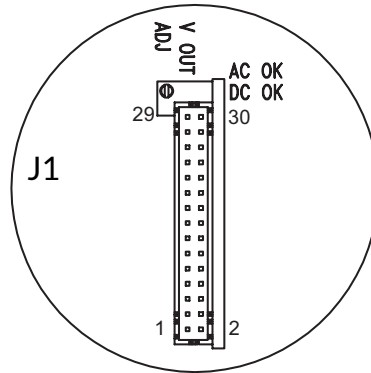

J1 signal connector connections			
Pin	Function	Opto-isolator	Description
1	DCOK	Collector	See circuit diagram on page 7. Uncommitted opto-isolator. Circuit conducting means Vout is within range.
2	DCOK return	Emitter	
3	Remote inhibit	Anode	See circuit diagram on page 7. Uncommitted opto-diode. Diode conducting means output OFF.
4	Remote inhibit return	Cathode	
5	A0		I ² C Device Address Bit (Internal 10kΩ pull-up to 3.3V)
6	A1		I ² C Device Address Bit (Internal 10kΩ pull-up to 3.3V)
7	A2		I ² C Device Address Bit (Internal 10kΩ pull-up to 3.3V)
8	CANH		CAN Bus Communication using CANopen protocol
9	RS485_Y		RS485 Differential Serial Bus Communication
10	CANL		CAN Bus Communication using CANopen protocol
11	RS485_Z		RS485 Differential Serial Bus Communication
12	SGND		Signal Return
13	UART_RX / RS232_RX/RS485_A		RS485 Differential Serial Bus Communication or RS232 Serial Bus Communication or UART
14	I ² C SDA		I ² C (Internal 10kΩ pull-up to 3.3V)
15	UART_TX / RS232_TX/RS485_B		RS485 Differential Serial Bus Communication or RS232 Serial Bus Communication or UART
16	I ² C SCL		I ² C Bus Clock (Internal 10kΩ pull-up to 3.3V)
17	FAN_FAIL/TEMP WARNING		Fan Failure/Temp Warning Reporting (High means fan fails and/or overtemperature rating; 10kΩ pull up to 3.3V) See circuit diagram on page 7.
18	SYNC		Connect parallel units to synchronise output turn on
19	VPROG		0 to 5V to set Vout from 0 to 105% ⁽¹⁾ (50.8kΩ internal resistance between Vprog and SGND ⁽²⁾)
20	RS+		Positive Remote Sense
21	RS-		Negative Remote Sense
22	IPROG		0 to 5V to set Current Limit from 0 to 110% of rated current ⁽¹⁾ (50.8kΩ internal resistance between Iprog and SGND)
23	ISHARE		0 to 2.6V for current sharing of units in parallel
24	PMBUS_EN		Selecting Digital (open) or Analog (low) mode for VPROG & IPROG (Internal 10kΩ pull up to 3.3V)
25	ACOK	Collector	See circuit diagram on page 7. Uncommitted opto-isolator. Circuit conducting means AC is within range.
26	ACOK Return	Emitter	
27	5VSBY		5V/2A Standby
28	5VSBY		5V/2A Standby
29	5VSBY_RTN		5V/2A Standby Return
30	5VSBY_RTN		5V/2A Standby Return

Notes:

1. In analog mode, the default Vout & Iout settings are 0% when Vprog & Iprog are open circuit.
2. To activate analog mode, PMBus_EN must be pulled down to SGND. Default if left open is digital programming.

Signals & controls

DC OK

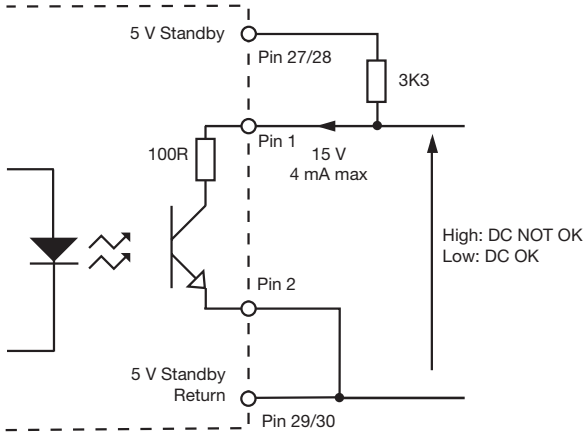

AC OK

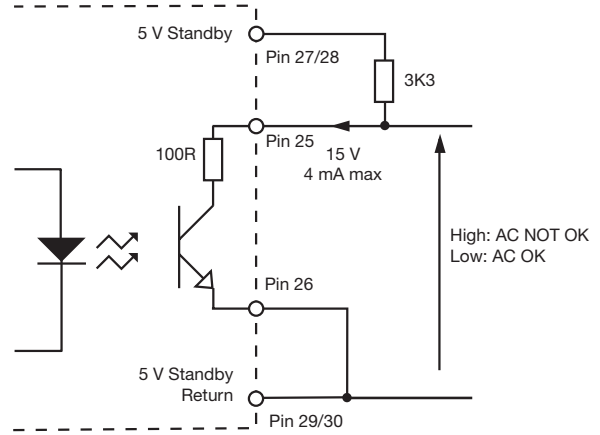

Fan fail/Temperature warning

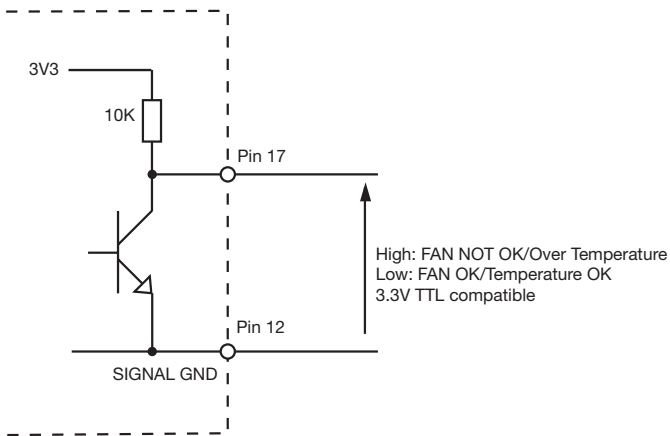

Inhibit

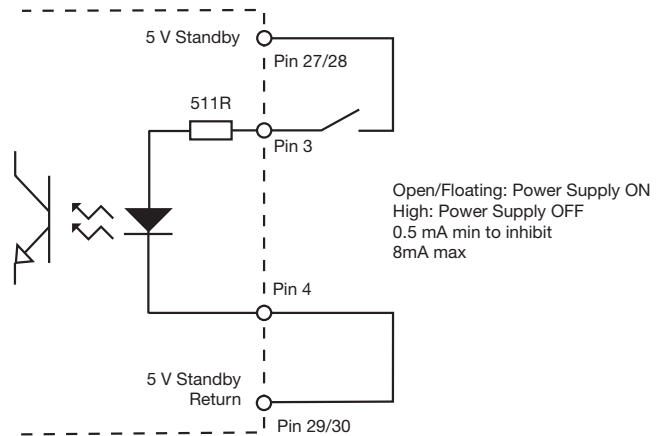

Signals & controls

Current share

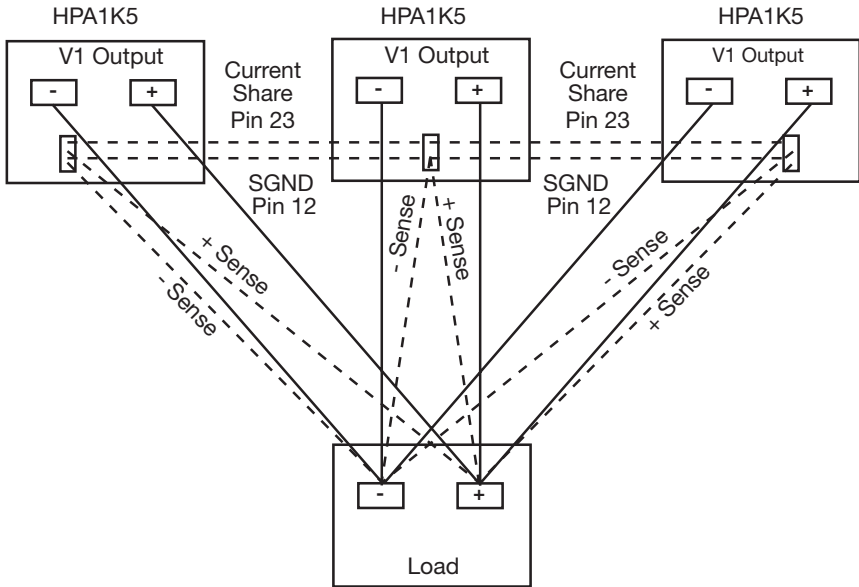

Up to 5 x HPA1K5 units

To synchronise output turn on from application of AC input, connect SYNC (pin 18) of parallel units together.

LED signals

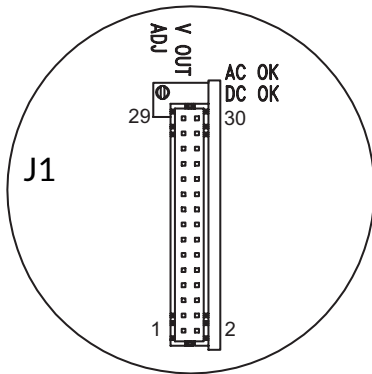

Conditions	LED state		Signals			
	AC OK	DC OK	AC OK	DC OK	FAN_FAIL/TEMP	Remote inhibit
AC input OK	ON	ON ⁽³⁾	LOW	LOW	LOW	LOW
AC not present or too low	OFF	OFF	HIGH	HIGH	LOW	X ⁽²⁾
AC present but out of range or PFC failure or no primary to secondary communication	Blink (0.2s ON, 0.2s OFF)	OFF	HIGH	HIGH	LOW	X ⁽²⁾
Output over voltage	ON	OFF	LOW	HIGH	LOW	LOW
Current limit (Constant current response)	ON	Blink (0.2s ON, 0.2s OFF)	LOW	LOW or HIGH ⁽³⁾	LOW	LOW
Fan failure/Thermal shutdown	ON	OFF	LOW	HIGH	HIGH ⁽¹⁾	LOW
Remote OFF	ON	Blink (1.0s ON, 1.0s OFF)	LOW	HIGH	LOW	HIGH
PMBus operation OFF	ON	Blink (1.0s ON, 1.0s OFF)	LOW	HIGH	LOW	LOW

Notes:

1. In case of fan failure, and/or overtemperature, FAN_FAIL/Temp Warning signal will be set 10s before output shutdown.
2. Don't care / not applicable.
3. DC_OK LED is ON if Output Voltage \geq VOUT_UV_FAULT_LIMIT, if Output Voltage $<$ VOUT_UV_FAULT_LIMIT, the DC_OK LED will be OFF

Mechanical details

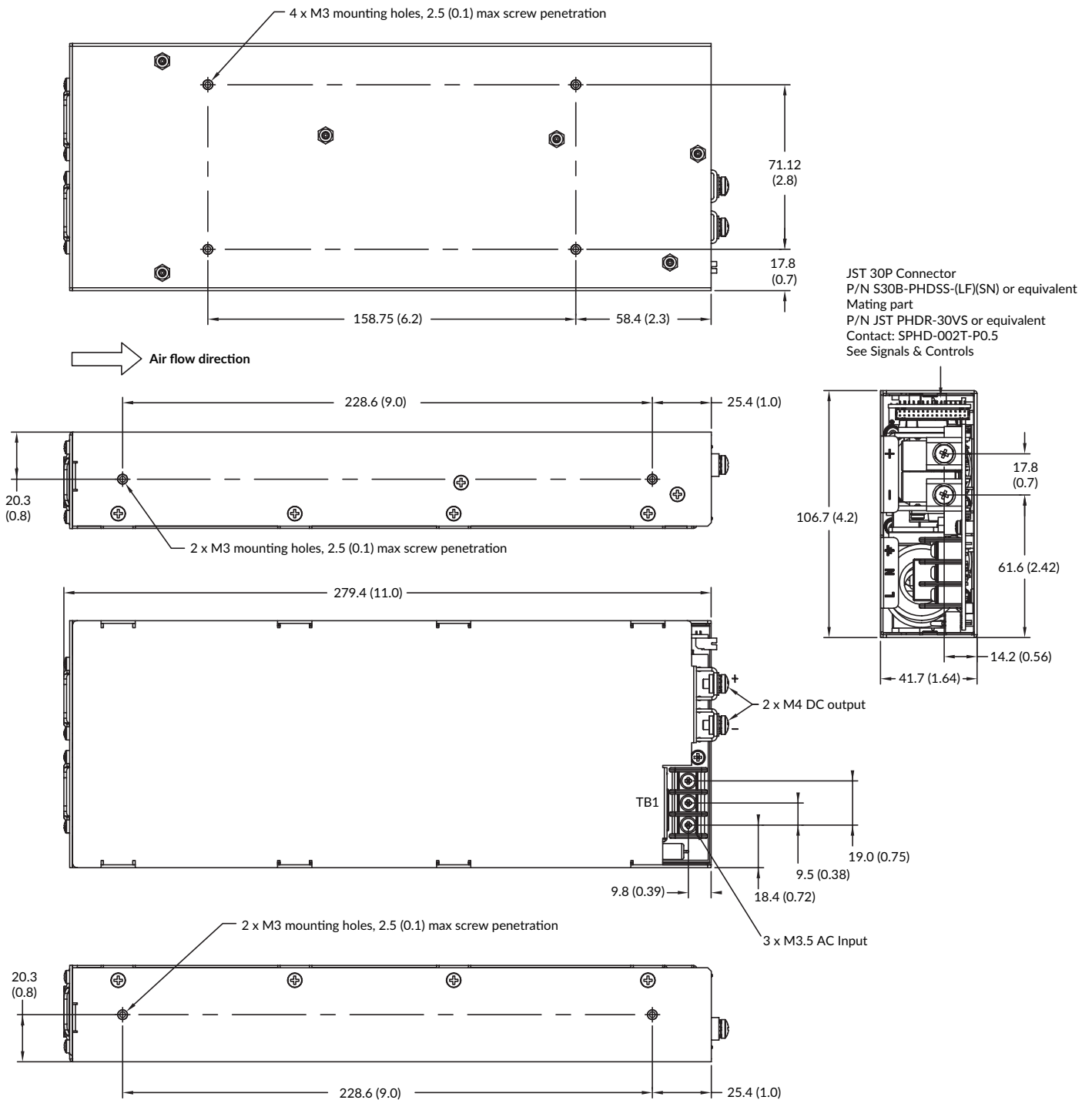

Notes:

1. In case of fan failure, and/or overtemperature, FAN_FAIL/Temp Warning signal will be set 10s before output shutdown.
2. Don't care / not applicable.
3. DC_OK LED is ON if Output Voltage \geq VOUT_UV_FAULT_LIMIT, if Output Voltage $<$ VOUT_UV_FAULT_LIMIT, the DC_OK LED will be OFF