

Very low power network processor module for Bluetooth® low energy v4.2

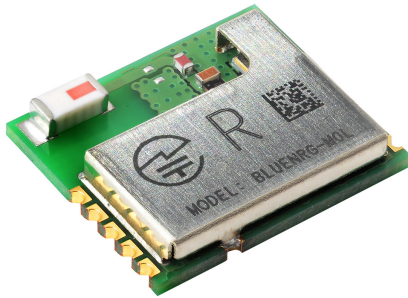

Features

- Bluetooth v4.2 compliant
 - Supports master and slave modes
 - Multiple roles supported simultaneously
- Embedded Bluetooth low energy protocol stack
 - GAP, GATT, SM, L2CAP, LL, RFPHY
- Bluetooth low energy profiles provided separately
- Embedded ST BlueNRG-MS network processor
 - Up to +8 dBm available output power
 - Down to -88 dBm Rx sensitivity
 - Up to 96 dB link budget with excellent link reliability
- Host interface
 - SPI, IRQ, and RESET
 - On-field stack upgrading available via SPI
- AES security co-processor
- Certification
 - CE qualified
 - FCC, IC modular approval certified
 - TYPE qualified
 - BQE qualified
 - WPC certification (BlueNRG-M0L)
- On-board chip antenna
- Operating supply voltage: from 1.7 to 3.6 V
- Operating temperature range: -40 °C to 85 °C

Product status link

[BlueNRG-M0](#)

Product label



Applications

- Watches
- Fitness, wellness and sports
- Consumer medical
- Security/proximity
- Remote control
- Home and industrial automation
- Assisted living
- Mobile phone peripherals
- PC peripherals

Description

The BlueNRG-M0 is an easy to use Bluetooth® low energy master/slave network processor module, compliant with Bluetooth v4.2. The BlueNRG-M0 module supports multiple roles simultaneously, and can act at the same time as Bluetooth low energy sensor and hub device.

The entire Bluetooth low energy stack and protocols are embedded into BlueNRG-M0 module. The external host application processor, where the application resides, is connected to the BlueNRG-M0 module through a standard SPI interface.

The BlueNRG-M0 module provides a complete RF platform in a tiny form factor. Radio, antenna, high frequency and LPO oscillators are integrated to offer a certified solution to optimize the time-to-market of the final applications.

The BlueNRG-M0 can be powered directly with a standard 3 V coin cell battery, a pair of AAA batteries or any power source from 1.7 to 3.6 V.

1 General description

The BlueNRG-M0 is a single-mode Bluetooth low energy master/slave network processor module compliant with Bluetooth® v4.2.

The BlueNRG-M0 module has been designed around the ST BlueNRG-MS network processor, on which a complete power-optimized stack for Bluetooth single mode protocol runs, providing

- Master, slave role support
- GAP: central, peripheral, observer or broadcaster roles
- ATT/GATT: client and server
- SM: privacy, authentication and authorization
- L2CAP
- Link Layer: AES-128 encryption and decryption

The BlueNRG-MS radio embeds non-volatile Flash memory allows on-field stack upgrading. In addition, according to the Bluetooth specification v4.2, the BlueNRG-M0 module provides:

- Multiple roles simultaneously support
- Support simultaneous advertising and scanning
- Support being slave of up to two masters simultaneously
- Privacy V1.1
- Low duty cycle directed advertising
- Connection parameters request procedure
- LE Ping
- 32 bits UUIDs
- L2CAP connection oriented channels

The BlueNRG-M0 module is equipped with Bluetooth low energy profiles in C source code, available for the ST radio BlueNRG-MS.

The external host application processor, where the application resides, is interfaced with the BlueNRG-M0 module through an application controller interface protocol, which is based on a standard SPI interface.

The BlueNRG-M0 module enables wireless connectivity into electronic devices, not requiring any RF experience or expertise for integration into the final product. The BlueNRG-M0 module provides a complete RF platform in a tiny form factor and being a certified solution optimizes the time-to-market of the final applications.

The BlueNRG-M0 module allows applications to meet of the tight advisable peak current requirements imposed with the use of standard coin cell batteries. Optimized results are obtained when the embedded high-efficiency DC-DC step-down converter is used (BLUENRG-M0A). Instead, concerning the BLUENRG-M0L the best performance in terms of power consumption is achieved using a 1.8V DC power supply.

The BlueNRG-M0 can be powered directly with a standard 3 V coin cell battery, a pair of AAA batteries or any power source from 1.7 to 3.6 V.

ST may update the FW provided with the modules at any time. ST recommends that users regularly check for documentation and the current FW version available at www.st.com/bluemodules.

2 Block diagram

Figure 1. HW block diagram for the BlueNRG-M0

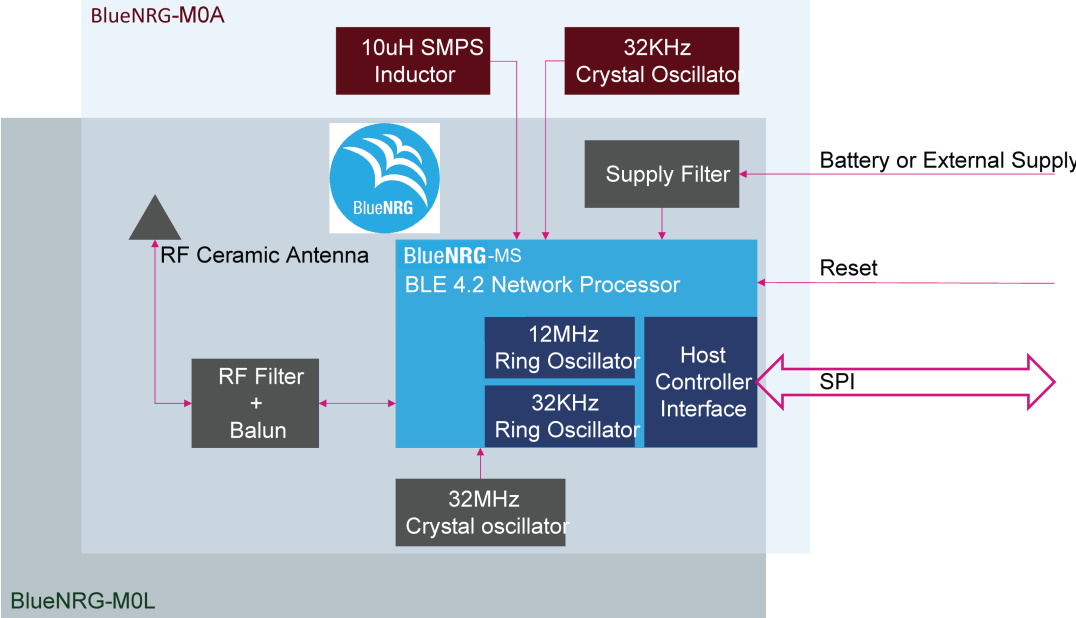

3 Software architecture

3.1 Bluetooth firmware implementation

The BlueNRG-M0 modules have been designed to work with an external host processor. The external host application processor, where the application resides, is interfaced with the BlueNRG-MS inside the BlueNRG-M0 modules through an application controller interface (ACI) protocol, which is based on a standard SPI slave interface as transport layer, basing on five physical wires:

- 2 control wires (Clock and "Chip Select")
- 2 data wires with serial shift-out (MOSI and MISO) in full duplex
- 1 wire to indicate data availability from the slave (IRQ)

All the SPI pins have an internal pull-down except for the CS that has a pull-up. All the SPI pins, except the CS, are in high impedance state during the low-power states. The IRQ pin needs a pull-down external resistor.

Figure 2. BlueNRG-M0 application block diagram

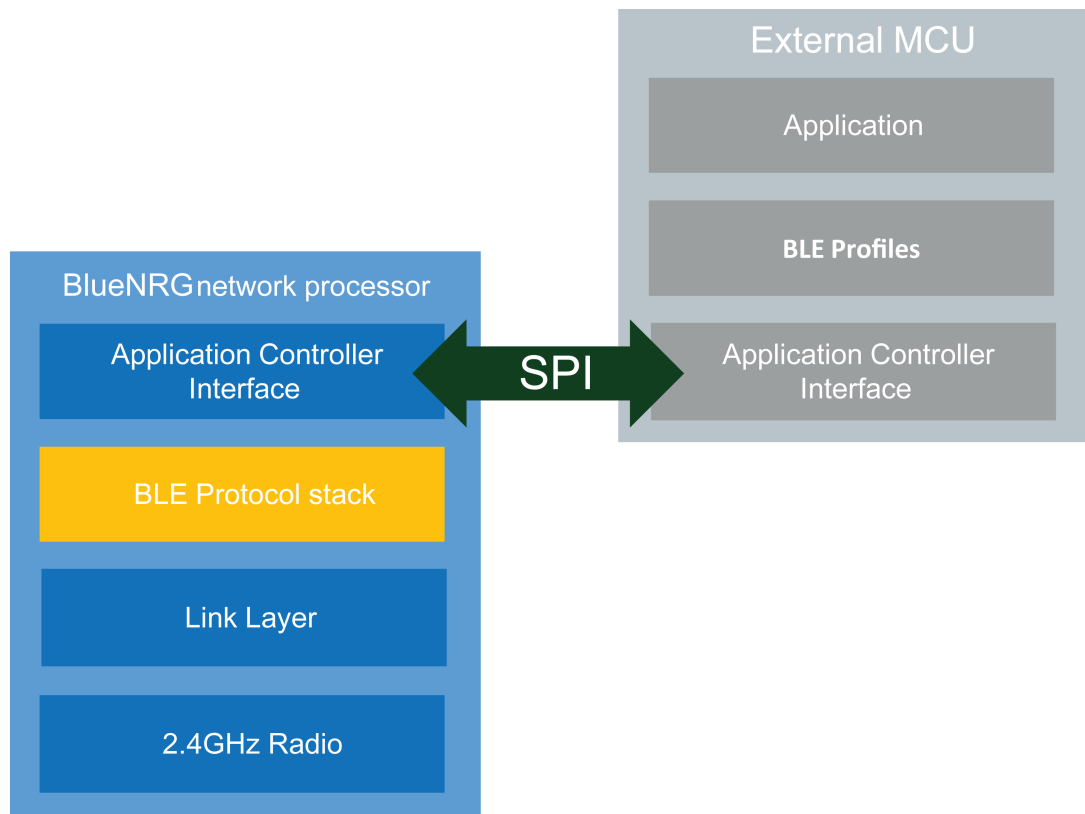

4 General characteristics

4.1 Absolute maximum ratings

Ratings	Min.	Typ.	Max.	Unit
Storage temperature range	-40	-	+85	°C
Supply voltage, VIN	-0.3	-	3.9	V
I/O pin Voltage (VIO five-volt tolerant pin)	-0.3	-	3.9	V
RF saturation input power	-	8	-	dBm
VESD-HBM Electrostatic discharge voltage		±2.0		kV

4.2 Operating conditions

Table 1. Operating conditions

Ratings	Min.	Typ.	Max.	Unit
Storage temperature range	-40	-	+85	°C
Operating ambient temperature range	-40	-	+85	°C
Supply voltage, VIN	1.7	3.3	3.6	V
Signals & I/O pin voltage (according supply voltage)	1.7	-	3.6	V
Frequency range	2402	-	2480	MHz

5 Electrical specifications

5.1 Electrical characteristics

Characteristic measured over recommended operating conditions unless otherwise specified. Typical values are referred to $V_{IN}=3.3\text{ V}$, $25\text{ }^{\circ}\text{C}$, SMPS on, XO 32 kHz and 32 MHz.

Table 2. Electrical characteristics for the BLUENRG-M0A

Symbol	Parameter	Test conditions	Min.	Typ.	Max.	Unit
IDD	Supply current	Reset		5		nA
		Standby		1.8		uA
		Sleep mode: 32 kHz XO ON (12 KB retention RAM)		1.7		μA
		Sleep mode: 32 kHz XO ON (24 KB retention RAM)		2.2		
		Active mode		2.12		mA
		RX		9.36		mA
		TX +8 dBm		16.50		mA
		TX +4 dBm		12.04		mA
		TX +2 dBm		10.40		mA
		TX -2 dBm		9.44		mA
		TX -5 dBm		8.79		mA
		TX -8 dBm		8.29		mA
		TX -11 dBm		8.01		mA
TX -14 dBm		7.82		mA		

Characteristic measured over recommended operating condition unless otherwise specified. Typical values are referred to $V_{IN}=3.3\text{ V}$, $25\text{ }^{\circ}\text{C}$, SMPS off, RO 32 kHz and 32 MHz.

Table 3. Electrical characteristics for the BLUENRG-M0L

Symbol	Parameter	Test conditions	Min.	Typ.	Max.	Unit
IDD	Supply current	Reset		5		nA
		Standby		1.7		uA
		Sleep mode: 32 kHz RO ON (12 KB retention RAM)		2.8		μA
		Sleep mode: 32 kHz RO ON (24 KB retention RAM)		3.2		
		Active mode		2.54		mA
		RX		16.36		mA
		TX +8 dBm		27.35		mA
		TX +4 dBm		21.3		mA
		TX +2 dBm		18.29		mA
		TX -2 dBm		16.44		mA

Symbol	Parameter	Test conditions	Min.	Typ.	Max.	Unit
IDD	Supply current	TX -5 dBm		15.18		mA
		TX -8 dBm		14.19		mA
		TX -11 dBm		13.61		mA
		TX -14 dBm		13.25		mA

5.2 Digital I/O specifications

IO pins are directly connected to the embedded state of the art BlueNRG-MS chipset. For more details about the digital I/O specification, please refer directly to the BlueNRG-MS datasheet available on www.st.com.

5.3 RF general characteristics

Characteristic measured over recommended operating conditions unless otherwise specified. Typical value are referred to $V_{IN}=3.3\text{ V}$, $25\text{ }^{\circ}\text{C}$, DC/DC on, XO 32 kHz (BLUENRG-M0A only) and XO 32 MHz.

Table 4. RF general characteristics

Symbol	Parameter	Test conditions	Min.	Typ.	Max.	Unit
FREQ	Frequency range		2400	-	2483.5	MHz
FCH	Channel spacing		-	2	-	MHz
RFch	RF channel center frequency		2402	-	2480	MHz

Table 5. BLUENRG-M0A RF characteristics

Symbol	Parameter	Test conditions	Min.	Typ.	Max.	Unit
RPMAX ⁽¹⁾	Output power ⁽²⁾	Radiated		+6		dBm
RXSENS	Sensitivity ⁽²⁾	Conducted		-85		dBm

1. PA-Level set to 0x07 and En-High_Power set to 0x01 (corresponding to +8 dBm in conducted mode).
2. Radiated power may be impacted by application board / housing / etc.

Table 6. BLUENRG-M0L RF characteristics

Symbol	Parameter	Test conditions	Min.	Typ.	Max.	Unit
RPMAX ⁽¹⁾	Radiated output power ⁽²⁾	Radiated		+6		dBm
RXSENS	Sensitivity ⁽²⁾	Conducted		-85		dBm

1. PA-Level set to 0x07 and En-High_Power set to 0x01 (corresponding to +8dBm in conducted mode)
2. Radiated power may be impacted by application board / housing / etc.

5.4 Pin assignment

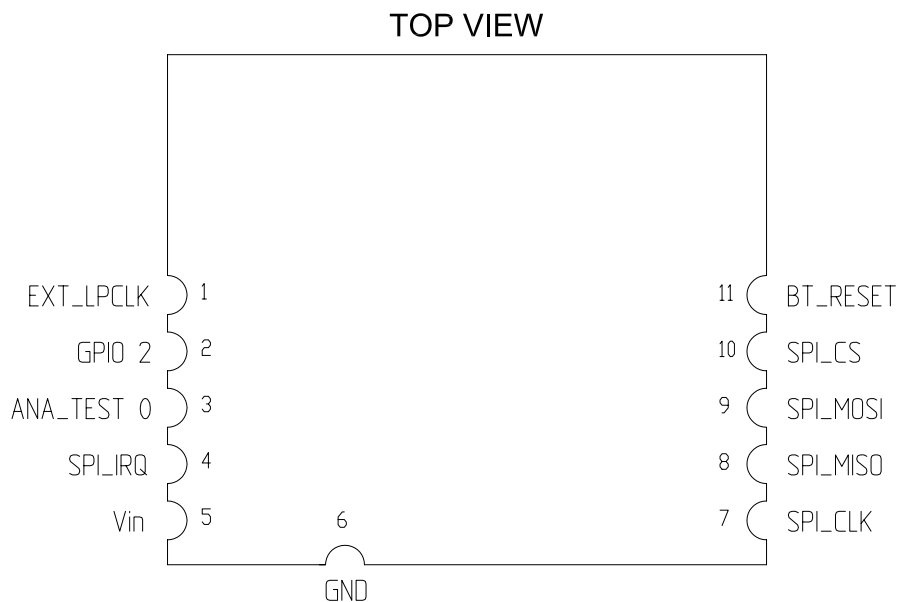
Figure 3. Pin connection

Table 7. Pin connection

Name	Type	Pin #	Description	V max. tolerant
SPI interface				
SPI_IRQ	O	4	SPI IRQ (SLAVE has data for MASTER)	V _{in}
SPI_CLK	I	7	SPI CLOCK (Max. 8 MHz)	V _{in}
SPI_MISO	O	8	SPI MISO (MASTER in / SLAVE out)	V _{in}
SPI_MOSI	I	9	SPI MOSI (MASTER out SLAVE in)	V _{in}
SPI_CS	I	10	SPI "Chip select" (SPI slave select)	V _{in}
Power and ground				
Vin		5	Vin	(1.7 V - 3.6 V max.)
GND		6	GND	
Reset				
BT_RESET	I	11	Reset input (active low < 0.35 V _{in})	(1.7 V - 3.6 V max.)
LPO				
EXT_LPCLK	I	1	Not connected	
GPIO2	I/O	2	Not connected	
ANA TEST 0	I	3	Not connected	

6 Hardware design

The BlueNRG-M0 module supports SPI hardware interfaces.

Note:

- All unused pins should be left floating; do not ground
- All GND pins must be well grounded
- The area around the module should be free of any ground planes, power planes, trace routings, or metal for 6 mm from the module antenna position, in all directions.
- Traces should not be routed underneath the module

6.1 Reflow soldering

The BlueNRG-M0 is a high temperature strength surface mount Bluetooth® module supplied on a 11-pin, 4-layer PCB. The final assembly recommended reflow profiles are indicated here below.

Soldering phase has to be executed with care: in order to avoid undesired melting phenomenon, particular attention has to be taken on the set up of the peak temperature.

Here are some suggestions for the temperature profile based on the following recommendations.

Table 8. Soldering profile

Profile feature	PB-free assembly
Average ramp up rate ($T_{S\text{MAX}}$ to T_p)	3°C/ sec max
Preheat temperature min (T_S min.)	150 °C
temperature max (T_S max.)	200 °C
time (t_S min to t_S max) (t_S)	60-100 s
Time maintained above Temperature T_L	217 °C
Time t_L	60-70 s
Peak temperature (T_p)	240+0 °C
Time within 5 °C of peak temperature ($T_p - 5^\circ$)	10-20 s
Ramp down rate	6 °C/s
Time from 25 °C to peak temperature	8 minutes max.

Figure 4. Soldering profiles

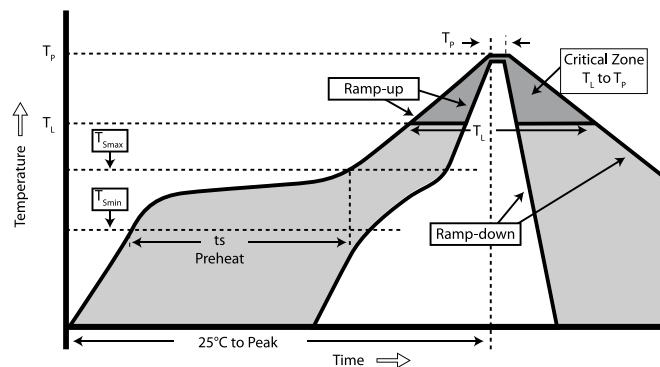

7 Regulatory compliance

7.1 FCC certification

This module has been tested and found to comply with the FCC part 15 rules. These limits are designed to provide reasonable protection against harmful interference in approved installations. This equipment generates, uses, and can radiate radio frequency energy and, if not installed and used in accordance with the instructions, may cause harmful interference to radio communications.

However, there is no guarantee that interference may not occur in a particular installation.

This device complies with part 15 of the FCC rules. Operation is subject to the following two conditions:

1. this device may not cause harmful interference
2. this device must accept any interference received, including interference that may cause undesired operation

Modifications or changes to this equipment not expressly approved by STMicroelectronics may render void the user's authority to operate this equipment.

Modular approval

FCC ID: S9NBNRGM0AL

In accordance with FCC part 15, the BlueNRG-M0 is listed as a modular transmitter device.

This module is evaluated for stand-alone use only. Finished products incorporating multiple transmitters must comply with collocation and RF exposure requirements in accordance with FCC multi-transmitter product procedures. Collocated transmitters operating in portable RF Exposure conditions (e.g. <20 cm from persons including but not limited to body worn and hand held devices) may require separate approval.

7.1.1 Labeling instructions

When the BlueNRG-M0 is integrated into the final product, the OEM must ensure that the FCC labeling requirements are satisfied. A statement must be included on the exterior of the final product which indicates the product includes a certified module. The label should state the following (or similar wording that conveys the same meaning):

Contains FCC ID: S9NBNRGM0AL

OR

This product contains FCC ID: S9NBNRGM0AL

The OEM must include the following statements on the exterior of the final product unless the product is too small (e.g. less than 4 x 4 inches):

This device complies with part 15 of the FCC rules. Operation is subjected to the following two conditions:

1. this device may not cause harmful interference and
2. this device must accept any interference received, including any interference that may cause undesired operations

7.1.2 Product manual instructions

This section applies to OEM final products containing the BlueNRG-M0 module, subjected to FCC compliance. The final product manual must contain the following statement (or a similar statement that conveys the same meaning):

Note: Changes or modifications not expressly approved by the party responsible for compliance could void the user's authority to operate the equipment. (Part. 15.21)

In the case where an OEM seeks Class B (residential) limits for the final product, the following statement must be included in the final product manual:

- Note:** *This equipment has been tested and found to comply with the limits for a Class B digital device, pursuant to part 15 of the FCC rules. These limits are designed to provide reasonable protection against harmful interference in a residential installation. This equipment generates, uses and can radiate radio frequency energy and, if not installed and used in accordance with the instructions, may cause harmful interference to radio communications. However, there is no guarantee that interference will not occur in a particular installation. If this equipment does cause harmful interference to radio or television reception, which can be determined by turning the equipment off and on, the user is encouraged to try to correct the interference by one or more of the following measures:*
- *Reorient or relocate the receiving antenna*
 - *Increase the separation between the equipment and receiver*
 - *Connect the equipment into an outlet on a circuit different from that to which the receiver is connected*
 - *Consult the dealer or an experienced radio/TV technician for help*

In the case where an OEM seeks the lesser category of a Class A digital device for the final product, the following statement must be included in the final product manual:

- Note:** *This equipment has been tested and found to comply with the limits for a Class A digital device, pursuant to part 15 of the FCC rules. These limits are designed to provide reasonable protection against harmful interference when the equipment is operated in a commercial environment. This equipment generates, uses, and can radiate radio frequency energy and, if not installed and used in accordance with the instruction manual, may cause harmful interference to radio communications. Operation of this equipment in a residential area is likely to cause harmful interference in which case the user will be required to correct the interference at his expense.*

7.2 IC certification

This device contains license-exempt transmitter(s)/receiver(s) that comply with innovation, science and economic development Canada's license-exempt RSS(s). Operation is subjected to the following two conditions:

1. this device may not cause interference

and

1. this device must accept any interference, including interference that may cause undesired operations of the device.

In addition, in accordance with RSS-102 clause 2.6, the RF exposure compliance distance of the BlueNRG-M0 is set equal to 15 mm.

Modular approval

IC: 8976C-BNRGM0AL

In accordance with IC RSS-247, the BlueNRG-M0 is listed as a modular transmitter device.

This module is evaluated for stand-alone use only. Finished products incorporating multiple transmitters must comply with collocation and RF exposure requirements in accordance with IC multi-transmitter product procedures. Collocated transmitters operating in portable RF Exposure conditions (e.g. <20 cm from persons including but not limited to body worn and hand held devices) may require separate approval.

7.2.1 Labeling instructions

When the BlueNRG-M0 is integrated into the final product, the OEM must ensure that the IC labeling requirements are satisfied. A statement must be included on the exterior of the final product which indicates that the product includes a certified module. The label should state the following (or similar wording that conveys the same meaning):

Contains IC: 8976C-BNRGM0AL

or

this product contains IC: 8976C-BNRGM0AL

The OEM must include the following statements on the exterior of the final product unless the product is too small (e.g. less than 4 x 4 inches):

This device complies with RSS-247 of the IC rules. Operation is subjected to the following two conditions:

1. this device may not cause harmful interference, and
1. this device must accept any interference received, including any interference that may cause undesired operation

7.2.2 Product manual instructions

This section applies to OEM final products containing the BlueNRG-M0 module, subjected to FCC compliance. The final product manual must contain the following statement (or a similar statement that conveys the same meaning):

Note: Changes or modifications not expressly approved by the party responsible for compliance could void the user's authority to operate the equipment. (RSS-247)

In the case where an OEM seeks Class B (residential) limits for the final product, the following statement must be included in the final product manual:

Note: This equipment has been tested and found to comply with the limits for a Class B digital device, pursuant to to RSS-247 of the IC rules. These limits are designed to provide reasonable protection against harmful interference in a residential installation. This equipment generates, uses and can radiate radio frequency energy and, if not installed and used in accordance with the instructions, may cause harmful interference to radio communications. However, there is no guarantee that interference will not occur in a particular installation. If this equipment does cause harmful interference to radio or television reception, which can be determined by turning the equipment off and on, the user is encouraged to try to correct the interference by one or more of the following measures:

- *Reorient or relocate the receiving antenna*
- *Increase the separation between the equipment and receiver*
- *Connect the equipment into an outlet on a circuit different from that to which the receiver is connected*
- *Consult the dealer or an experienced radio/TV technician for help*

In the case where an OEM seeks the lesser category of a Class A digital device for the final product, the following statement must be included in the final product manual:

Note: This equipment has been tested and found to comply with the limits for a Class A digital device, pursuant to RSS-247 of the IC rules. These limits are designed to provide reasonable protection against harmful interference when the equipment is operated in a commercial environment. This equipment generates, uses, and can radiate radio frequency energy and, if not installed and used in accordance with the instruction manual, may cause harmful interference to radio communications. Operation of this equipment in a residential area is likely to cause harmful interference in which case the user will be required to correct the interference at his expense.

7.3 CE certification

The BlueNRG-M0 module has been certified according to the following certification rules:

- ETSI EN 300 328 V 2.1.1 (2016-11)⁽¹⁾
- ETSI EN 301 489-17 V3.1.1 (2017-02)⁽²⁾
- ETSI EN 301 489-1 V2.1.1 (2017-02)⁽³⁾
- EN 62368-1:2020/A11:2020⁽⁴⁾
- EN 62311:2008

1. ETSI EN 300 328 V 2.1.1 (2016 11): "electromagnetic compatibility and radio spectrum Matters (ERM); Wideband transmission systems; data transmission equipment operating in the 2.4 GHz ISM band and using wideband modulation techniques; harmonized EN covering essential requirements under article 3.2 of the R&TTE directive".
2. ETSI EN 301 489-17 V 3.1.1 (2017 02): "electromagnetic compatibility and radio spectrum matters (ERM); electromagnetic compatibility (EMC) standard for radio equipment and services; part 17: specific condition for 2.4 GHz wideband transmission systems and 5 GHz high performance RLAN equipment".
3. ETSI EN 301 489-1 V2.1.1 (2017 02): "electromagnetic compatibility and radio spectrum matters (ERM); electromagnetic compatibility (EMC) standard for radio equipment and services; part 1: common technical requirements".
4. EN 62368-1:2020/A11:2020: "Audio/video, information and communication technology equipment - Part 1: Safety requirements".

The module is provided by CE marking:



The module has obtained the RED certificate: No. 0051-RED-0097

The Certificate of Conformity is available / downloadable at the following web page: www.ST.com/product/bluenrg-m0.

The certified module production firmware release is: 7.X

For additional information please refer to: STMicroelectronics Via C. Olivetti 2, Agrate Brianza 20864 (ITALY).

7.4 TYPE certification

The BlueNRG-M0 module has been tested according to following TYPE certification rules:

- Type of specified radio equipment
 - Radio equipment according to certification ordinance article 2-1-9
- Sophisticated low power radio data communication system in 2.4 GHz band.
- Class of emissions, assigned frequency, and antenna power
 - F1D 2402 - 2480 MHz channel separation 2 MHz/40 channel, 0.005 W
- Certification number:
 - 006-000713 (BLUENRG-M0A)
 - 006-000714 (BLUENRG-M0L)

7.5 WPC ETA certificate

The BlueNRG-M0L module is registered for equipment type approval (ETA) with WPC India.

- Registration No: ETA-SD-20201108376

7.6 Bluetooth certification

The module with embedded stack and profile has been qualified in accordance with SIG qualification rules:

- Declaration ID: D043964
- Qualified design ID: 122868
- Product type: End Product
- Core spec version: 4.2
- Product description: Bluetooth low energy v4.2 module

8 Package information

In order to meet environmental requirements, ST offers these devices in different grades of **ECOPACK** packages, depending on their level of environmental compliance. ECOPACK specifications, grade definitions and product status are available at: www.st.com. ECOPACK is an ST trademark.

8.1 BlueNRG-M0 package information

Figure 5. BlueNRG-M0 package outline

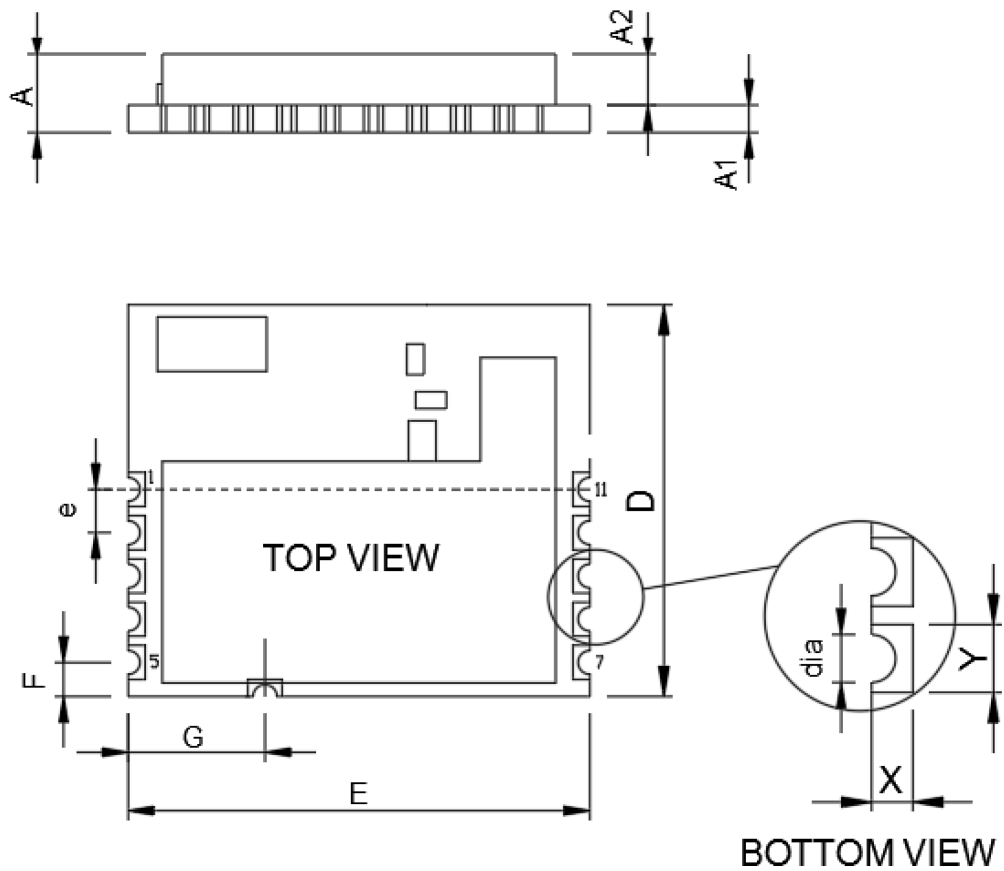
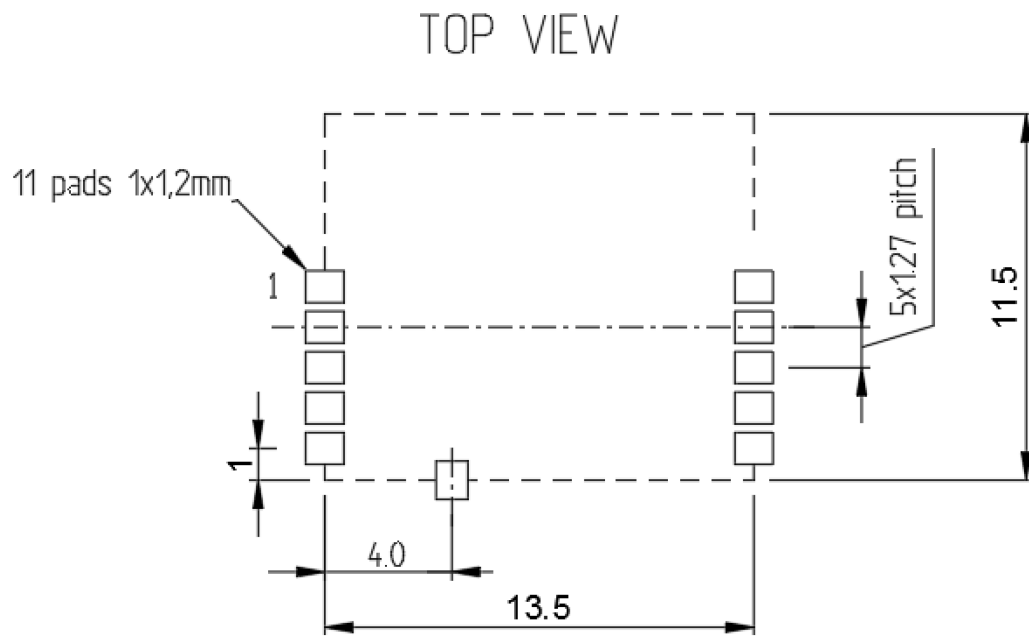

Table 9. BlueNRG-M0 mechanical data

Symbol	mm		
	Min.	Typ.	Max.
A	2.1	2.3	2.5
A1	0.7	0.8	0.9
A2	1.4	1.5	1.6
D		11.5	
E		13.5	
F		1	
G		4.0	
dia		0.7	
Pad size X,Y (on bottom side)		0.6x1	
e-pitch		1.27	tol. +/-0.025

Figure 6. BlueNRG-M0 recommended footprint



RECOMMENDED LAND PATTERN
All Dimensions are in millimeters

Figure 9. BlueNRG-M0 reel outline

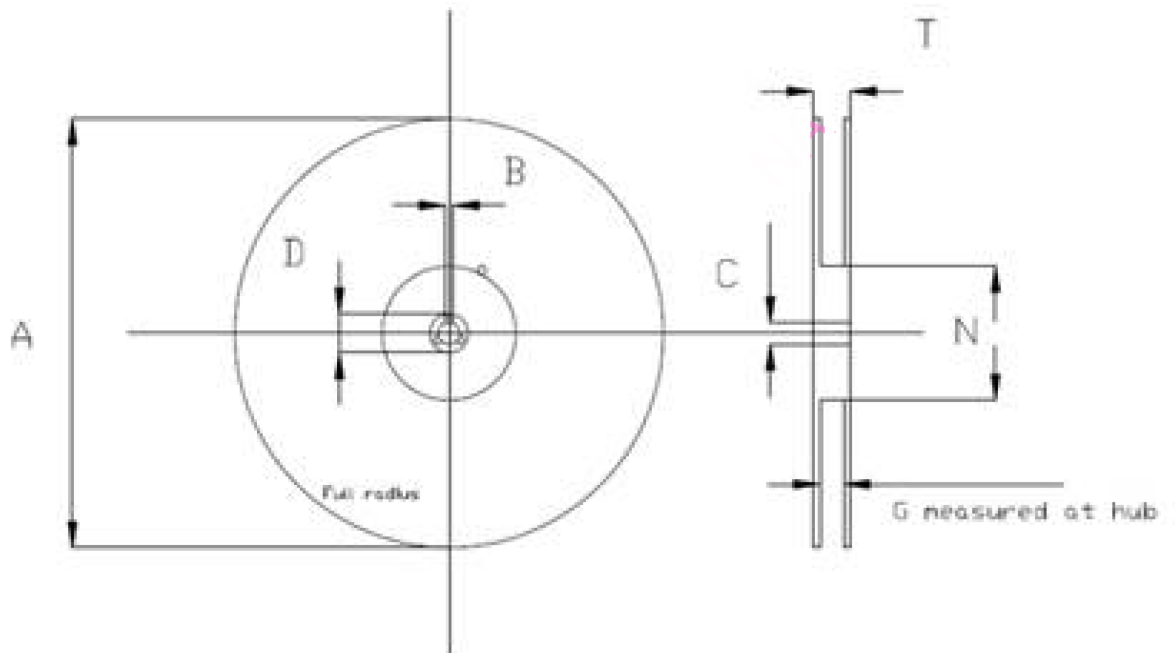

Table 10. BlueNRG-M0 reel mechanical data

Dimensions	Reel	
	Min.	Max.
A	328	332
B	1.5	
C	12.8	13.5
D	20.2	
G	24.4	26.4
N	100	103
T	26.4	30.4

9 Ordering information

Table 11. Ordering information

Order code	Description	MOQ	Packing
BLUENRG-M0A	Bluetooth® v4.2 low energy module	1000 pieces	Tape and reel
BLUENRG-M0L			

10 Traceability

Each module is univocally identified by serial number stored in a 2D data matrix laser marked on the top side (shield) of the module itself.

Each module bulk is identified by a bulk ID.

Bulk ID and module 2D data matrix are linked by a reciprocal traceability link. The module 2D data matrix traces the lot number of any raw material used according to following rules:

Table 12. Traceability information

Letter	Meaning
HA	Reserved
YWW	Year and week number
E	Reserved
LL	Lot sequence number
XX	Lot sub-sequence number
0000	Serial number

Revision history

Table 13. Document revision history

Date	Version	Changes
29-May-2019	1	Initial release.
23-Jul-2019	2	Added logo to cover page. Updated features in cover page, Table 5. BLUENRG-M0A RF characteristics and Table 6. BLUENRG-M0L RF characteristics. Added Section 8.2 BlueNRG-M0 packing information.
13-Mar-2020	3	Updated Figure 1. HW block diagram for the BlueNRG-M0.
13-Jan-2021	4	Updated cover image. Updated Table 8. Soldering profile. Updated Section 7.3 CE certification
04-Mar-2021	5	Updated Section Features. Added Section 7.5 WPC ETA certificate.

Contents

1	General description	3
2	Block diagram	4
3	Software architecture	5
3.1	Bluetooth firmware implementation.....	5
4	General characteristics	6
4.1	Absolute maximum ratings.....	6
4.2	Operating conditions.....	6
5	Electrical specifications	7
5.1	Electrical characteristics.....	7
5.2	Digital I/O specifications.....	8
5.3	RF general characteristics.....	8
5.4	Pin assignment.....	9
6	Hardware design	10
6.1	Reflow soldering.....	10
7	Regulatory compliance	11
7.1	FCC certification.....	11
7.1.1	Labeling instructions.....	11
7.1.2	Product manual instructions.....	11
7.2	IC certification.....	12
7.2.1	Labeling instructions.....	12
7.2.2	Product manual instructions.....	13
7.3	CE certification.....	13
7.4	TYPE certification.....	15
7.5	WPC ETA certificate.....	15
7.6	Bluetooth certification.....	15
8	Package information	16
8.1	BlueNRG-M0 package information.....	16
8.2	BlueNRG-M0 packing information.....	18
9	Ordering information	20



10 Traceability21

Revision history22

List of tables

Table 1.	Operating conditions	6
Table 2.	Electrical characteristics for the BLUENRG-M0A	7
Table 3.	Electrical characteristics for the BLUENRG-M0L	7
Table 4.	RF general characteristics.	8
Table 5.	BLUENRG-M0A RF characteristics	8
Table 6.	BLUENRG-M0L RF characteristics.	8
Table 7.	Pin connection.	9
Table 8.	Soldering profile.	10
Table 9.	BlueNRG-M0 mechanical data.	17
Table 10.	BlueNRG-M0 reel mechanical data	19
Table 11.	Ordering information.	20
Table 12.	Traceability information.	21
Table 13.	Document revision history	22

List of figures

Figure 1.	HW block diagram for the BlueNRG-M0	4
Figure 2.	BlueNRG-M0 application block diagram	5
Figure 3.	Pin connection	9
Figure 4.	Soldering profiles	10
Figure 5.	BlueNRG-M0 package outline	16
Figure 6.	BlueNRG-M0 recommended footprint	17
Figure 7.	BlueNRG-M0 tape outline	18
Figure 8.	BlueNRG-M0 tape dimension outline	18
Figure 9.	BlueNRG-M0 reel outline	19

IMPORTANT NOTICE – PLEASE READ CAREFULLY

STMicroelectronics NV and its subsidiaries (“ST”) reserve the right to make changes, corrections, enhancements, modifications, and improvements to ST products and/or to this document at any time without notice. Purchasers should obtain the latest relevant information on ST products before placing orders. ST products are sold pursuant to ST’s terms and conditions of sale in place at the time of order acknowledgement.

Purchasers are solely responsible for the choice, selection, and use of ST products and ST assumes no liability for application assistance or the design of Purchasers’ products.

No license, express or implied, to any intellectual property right is granted by ST herein.

Resale of ST products with provisions different from the information set forth herein shall void any warranty granted by ST for such product.

ST and the ST logo are trademarks of ST. For additional information about ST trademarks, please refer to www.st.com/trademarks. All other product or service names are the property of their respective owners.

Information in this document supersedes and replaces information previously supplied in any prior versions of this document.

© 2021 STMicroelectronics – All rights reserved