

HC872XF



Multi-Constellation Dual-Band Antenna

Frequency Coverage: GPS L1, L2 | GALILEO E1 | BEIDOU B1 | GLONASS G1, G2 + L-Band

The patented HC872XF helical antenna is designed for precision positioning, covering the GPS/QZSS-L1/L2, GLONASS-G1/G2, Galileo-E1, and BeiDou-B1 frequency bands, including the satellite-based augmentation system (SBAS) available in the region of operation [WAAS (North America), EGNOS (Europe), MSAS (Japan), or GAGAN (India)], as well as and L-Band correction services.

Calian's eXtended Filter (XF) antenna technology has been designed to mitigate out-of-band signals and prevent GNSS antenna saturation. The radio frequency spectrum has become more congested as new LTE bands are activated and their signals or harmonic frequencies [e.g. $800\text{MHz} \times 2 = 1600\text{MHz}$ (GLONASS-G1)] can affect GNSS antennas and receivers. In North America, planned Ligado signals at 1525 - 1536 MHz can especially impact GNSS antennas that support space-based L-band correction services (1539 - 1559 MHz). New LTE signals in Europe [Band 32 (1452 - 1496 MHz)] and Japan [Bands 11 and 21 (1476 - 1511 MHz)] have also been observed to interfere with GNSS signals. In addition, Inmarsat satellite communication (uplink: 1626.5 - 1660.5 MHz) can also affect GNSS signals. Calian's custom XF filtering mitigates all existing signals and new Ligado and LTE signals, enabling the antennas and attached GNSS receivers to perform optimally.

Weighing only 42 g, the light and compact HC872XF features a precision-tuned helix element that provides excellent axial ratios and operates without the requirement of a ground plane, making it ideal for a variety of applications, including uncrewed aerial vehicles (UAVs).

All Tallysman housed helical antenna elements are protected by a robust military-grade IP69K-compliant plastic enclosure. The enclosure's base provides two threaded inserts for secure attachment, as well as a rubber O-ring around the outer edge to seal the antenna base and its integrated male SMA connector.

Calian's helical family has passed a rigorous 30-hour vibration test procedure, consisting of five cycles of 2-hour tests per axis (x, y, z):

- Cycle 1: 1.05 Grms;
- Cycle 2: 1.20 Grms;
- Cycle 3: 1.35 Grms;
- Cycle 4: 3.67 Grms;
- Cycle 5: 3.67 Grms.

Mounting instructions available on our product page.



Applications

- Autonomous uncrewed aerial vehicles (UAVs)
- Precision GNSS positioning
- Precision land survey positioning
- Mission-critical GNSS timing
- Network timing and synchronization
- Sea and land container tracking
- Fleet management and asset tracking
- Marine and avionics systems
- Law enforcement and public safety

Features

- Very low noise preamp (2.5 dB typ.)
- Axial ratio (≤ 0.5 dB at zenith)
- LNA gain (28 dB typ., 35 dB typ.)
- Low current (26 mA typ. (28 dB), 32 mA typ. (35 dB))
- ESD circuit protection (15 kV)
- Invariant performance from 2.5 to 16 VDC
- IP69K, REACH, and RoHS compliant

Benefits

- Extremely light (42 g)
- Ideal for RTK and PPP surveying systems
- Excellent RH circular polarized signal reception
- Great multipath rejection
- Increased system accuracy
- Excellent signal-to-noise ratio
- Industrial temperature range
- Rugged design, ideal for harsh environments
- Extended RF Filtering

About Calian: With global headquarters and manufacturing in Ottawa, Canada, Calian is a leading manufacturer of high-precision antennas and components for Global Navigation Satellite System (GNSS) applications. Calian's mission is to support the needs of a new generation of positioning systems by delivering unprecedented antenna precision at competitive prices. Learn more at www.calian.com/gnss

Revision: 202203

Contact us:
info.gnss@calian.com
T: +1 613 591-3131

Multi-Constellation Dual-Band Antenna

Frequency Coverage: GPS L1, L2 | GALILEO E1 | BEIDOU B1 | GLONASS G1, G2 + L-Band

Antenna

Technology Dual-frequency, RHCP quadrifilar helix

		Gain	Axial Ratio
		dBic typ. at Zenith	dB at Zenith
GNSS			
GPS / QZSS	L1	2.5	≤ 0.5
	L2	2.8	≤ 0.5
	L5	-	-
GLONASS	G1	1.8	≤ 0.5
	G2	1.9	≤ 0.5
	G3	-	-
Galileo	E1	2.5	≤ 0.5
	E5A	-	-
	E5B	-	-
	E6	-	-
BeiDou	B1	2.5	≤ 0.5
	B2b	-	-
	B2a	-	-
	B3	-	-
IRNSS / NavIC	L5	-	-
QZSS	L6	-	-
L-Band Services (1525 MHz - 1559 MHz)		2.2	≤ 0.5
Satellite Communications			
Iridium		-	-
Globalstar		-	-
Other			
Axial Ratio at 10°	-	Efficiency	-
PC Variation	± 3.0 mm (all freq.)	PCO (mm)	32 (L1), 37 (L2)

Mechanicals

Mechanical Size	44.2 mm (dia.) x 62.4 mm (h.)
Weight	42 g
Radome	LEXAN™ EXL9330
Mount	3x M2.5 screws
Available Connectors	SMA (male)

Environmental

Operating Temperature	-40 °C to +85 °C
Storage Temperature	-55 °C to +95 °C
Vibration	MIL-STD-810-G - Test Method 514.6
Shock	MIL-STD-810-G - Test Method 516.6
Salt Fog	MIL-STD-810-G - Test Method 509.6
IP Rating	IP69K
Compliance	IPC-A-610, FCC, RED / CE Mark, RoHS, REACH

Warranty

Parts and Labour	3-year standard warranty
------------------	--------------------------

Low Noise Amplifier (LNA) - Measured at 3V and 25°C

Frequency Bandwidth	Out of Band Rejection
Lower Band	1215 - 1254 MHz
L-Band Corr.	1540 - 1559 MHz
Upper Band	1559 - 1606 MHz

Out of Band Rejection
> 64 dB @ > 1400 MHz
> 32 dB @ < 1526 MHz
> 06 dB @ < 1536 MHz
> 50 dB @ > 1626 MHz
> 64 dB @ > 1700 MHz
> 69 dB @ < 700 MHz
> 63 dB @ < 1000 MHz
> 42 dB @ < 1180 MHz
> 63 dB @ < 1325 MHz
> 76 dB @ < 1400 MHz

Architecture	eXtended Filtering
Gain	28 dB typ., 35 dB typ.
Noise Figure	2.5 dB typ.
VSWR	< 1.5:1 typ., 1.8:1 max.
Supply Voltage Range	2.5 to 16 VDC nominal, up to 50mV p-p ripple
Supply Current	26 mA typ. (28 dB), 32 mA typ. (35 dB)
ESD Circuit Protection	15 kV air discharge
P 1dB Output	11 dBm typ.
Group Delay	20 ns (L1), 8 ns (L2)

Mechanical Diagram - Units in 'mm'

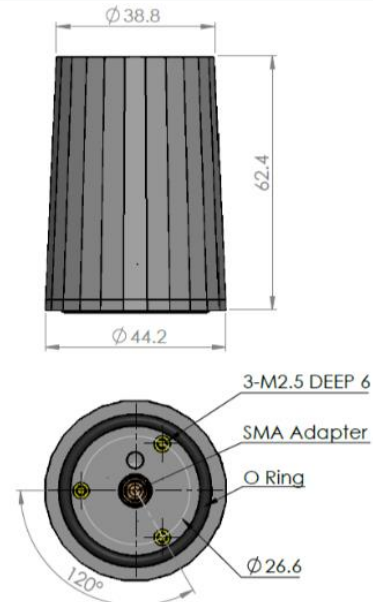

Ordering Information

Part Number	33-HC872XF-xx
	where xx = gain (28 or 35 dB)

Please refer to our **Ordering Guide** to review available radomes and connectors at: <https://at.calian.com/gnss/information-support/part-number-ordering-guide/>