

Ultra-Low Power Wi-Fi + Bluetooth® LE Combo Module

General Description

The DA16600 series is a highly integrated ultra-low-power Wi-Fi + Bluetooth® Low Energy Combo Module solution. This module includes the DA16200 that has an 802.11b/g/n radio (PHY), a baseband processor, a media access controller (MAC), on-chip memory, and a host networking application processor. DA16600 also has a DA14531 that has a 2.4 GHz transceiver and an Arm® Cortex-M0+® microcontroller with a RAM of 48 kB and a One-Time Programmable (OTP) memory of 32 kB. The radio transceiver, the baseband processor, and the qualified Bluetooth® low energy stack is fully compliant with the Bluetooth Low Energy 5.1 standard.

The DA16600 is a synthesis of breakthrough ultra-low-power technologies, which enables an extremely low power operation in the module. The DA16200 and DA14531 shut down every micro element of the chip that is not in use, which creates a power consumption that is near zero when not actively transmitting or receiving data. Such low power operation can extend the battery life up to a year or more depending on the application. The DA16600 also enables ultra-low power transmission and reception modes when the SoC needs to be awake to exchange information with other devices. Advanced algorithms enable sleep mode until the exact moment when wake up is required to transmit or receive data.

Module Features

- Module Variants
 - DA16600MOD-AAC4WA32 (Chip Antenna)
 - DA16600MOD-AAE4WA32 (u.FL Connector)
- Dimensions
 - 14.3 mm × 24.3 mm × 3.0 mm, 51-Pins
- Ambient operating temperature range
 - -40 °C to 85 °C
- Regulatory certifications:
 - FCC
 - IC
 - CE
 - TELEC

Wi-Fi Features

- Highly integrated ultra-low power Wi-Fi® system on a chip
- RF Performance
 - Tx Power: +18 dBm, 1 Mbps DSSS
 - Rx Sensitivity: -97.5 dBm, 1 Mbps DSSS
- Full offload: SoC runs full networking OS and TCP/IP stack
- Hardware accelerators
 - General HW CRC engine
 - HW zeroing function for fast booting
 - Pseudo random number generator (PRNG)
- SPI flash Memory
- Wi-Fi processor
 - IEEE 802.11b/g/n, 1x1, 20 MHz channel bandwidth, 2.4 GHz
 - Wi-Fi security: WPA/WPA2-Enterprise/Personal, WPA2 SI, WPA3 SAE, and OWE
 - Vendor EAP types: EAP-TTLS/MSCHAPv2, PEAPv0/EAP-MSCHAPv2, PEAPv1, EAP-FAST, and EAP-TLS
 - Operating modes: Station, Soft AP
 - WPS-PIN/PBC for easy Wi-Fi provisioning
 - Fast Wi-Fi connections

Ultra-Low Power Wi-Fi + Bluetooth® LE Combo Module

- 32 M-bit / 4 M-byte
- Complete software stack
 - Comprehensive networking software stack
 - Provides TCP/IP stack in the form of network socket APIs
- CPU core subsystem
 - Arm® Cortex®-M4F core with clock frequency of 30~160 MHz
 - ROM: 256 KB, SRAM: 512 KB, OTP: 8 KB, Retention Memory: 48 KB
- Advanced security
 - Secure booting
 - Secure debugging using JTAG/SWD and UART ports
 - Secure asset storage
- Built-in hardware crypto engines for advanced security
 - TLS/DTLS security protocol functions
 - Crypto engine for key deliberate generic security functions: AES (128,192,256), DES/3DES, SHA1/224/256, RSA, DH, ECC, CHACHA, and TRNG
- Supports various interfaces
 - Two UARTs
 - SPI Master/Slave interface
 - I2C Master/Slave interface
 - I2S for digital audio streaming
 - 4-channel PWM
 - Individually programmable, multiplexed GPIO pins
 - JTAG and SWD
- Built-in 2-channel auxiliary ADC for sensor interfaces
 - 12-bit SAR ADC: single-ended two channels
- Supply
 - Operating voltage: 2.1 V to 3.6 V (typical: 3.3 V)
 - 2 Digital I/O Supply Voltage: 1.8 V / 3.3 V
 - Black-out and brown-out detector
- Power management unit
 - On-Chip RTC
 - Wake-up control of fast booting or full booting with minimal initialization time
 - Supports three ultra-low power sleep modes

Bluetooth Features

- Bluetooth
 - Compatible with Bluetooth® v5.1, ETSI EN 300 328 and EN 300 440 Class 2 (Europe), FCC CFR47 Part 15 (US) and ARIB STD-T66 (Japan) core
 - Supports up to 3 connections
- Processing and memories
 - 16 MHz 32-bit Arm®Cortex-M0+ with SWD interface
 - 48 Kbytes RAM
 - 144 Kbytes ROM
 - 32 Kbytes OTP
- Current Consumption
 - 2 mA RX at VBAT = 3V
 - 4 mA TX at VBAT = 3 V and 0 dBm
 - 1.8 uA at sleep with all RAM retained
- Radio
 - Programmable RF transmit power
 - -93 dBm receiver sensitivity
- Interfaces
 - 2 channel 11-bit ENOB ADC
 - 2 general purpose timers with PWM
 - 5 GPIOs
 - SPI
 - 2x UART, 1-wire UART support
 - I2C
- Power management
 - Operating range (1.8 V - 3.3 V)
 - Inrush current control
- Other
 - Real Time Clock
 - Trimmed 32 MHz Crystal

Ultra-Low Power Wi-Fi + Bluetooth® LE Combo Module

Contents

1	References	5
2	Block Diagram	6
3	Pinout	7
3.1	Pinout Description (51-pins).....	7
3.2	Pin Multiplexing	10
4	Electrical Specification	11
4.1	Absolute Maximum Ratings	11
4.2	Recommended Operating Conditions.....	11
4.3	Electrical Characteristics.....	11
4.3.1	DC Parameters, 1.8 V IO.....	11
4.3.2	DC Parameters, 3.3 V IO.....	12
4.3.3	DC Parameters for RTC Block	12
4.4	Radio Characteristics	13
4.4.1	Wi-Fi Characteristics.....	13
4.4.2	Bluetooth® LE Characteristics.....	14
4.5	Current Consumption	14
4.5.1	Wi-Fi Characteristics.....	14
4.5.2	Bluetooth® LE Characteristics.....	15
4.6	Radiation Performance	16
4.7	ESD Ratings.....	16
5	Power-on Sequence	17
6	Applications Schematic	18
6.1	Typical Application	18
7	Package Information	19
7.1	Dimension: DA16600MOD-AAC	19
7.2	Dimension: DA16600MOD-AAE	19
7.3	PCB Land Pattern	20
7.4	4-layer PCB Example.....	22
7.5	Soldering Information	23
7.5.1	Recommended Condition for Reflow Soldering	23
8	Ordering Information	24
	Revision History	25

Ultra-Low Power Wi-Fi + Bluetooth® LE Combo Module

Figures

Figure 1: DA16600 Block Diagram.....	6
Figure 2: DA16600MOD 51-Pins Pinout Diagram (Top View)	7
Figure 3: TIS 3D	16
Figure 4: TRP 3D.....	16
Figure 5: Power On Sequence	17
Figure 6: Typical Application	18
Figure 7: AAC Module Dimension	19
Figure 8: AAE Module Dimension	20
Figure 9: PCB Land Pattern (Top View).....	20
Figure 10: PCB Land Pattern (Bottom View).....	21
Figure 11: 4-Layer PCB Example.....	22
Figure 12: Reflow Condition	23

Tables

Table 1: Pin Description	8
Table 2: DA16200 Pin Multiplexing	10
Table 3: Absolute Maximum Ratings.....	11
Table 4: Recommended Operating Conditions	11
Table 5: DC Parameters, 1.8 V IO	11
Table 6: DC Parameters, 3.3 V IO	12
Table 7: DC Parameters for RTC block, 3.3 V VBAT	12
Table 8: DC Parameters for RTC block, 2.1 V VBAT.....	12
Table 9: Wi-Fi Receiver Characteristics	13
Table 10: Wi-Fi Transmitter Characteristics	13
Table 11: Radio 1 Mb/s – AC Characteristics	14
Table 12: Current Consumption in Active State	14
Table 13: Current Consumption in Low Power Operation.....	14
Table 14: DC Characteristics.....	15
Table 15: ESD Performance.....	16
Table 16: Power On Sequence Timing Requirements.....	17
Table 17: Coexistence Connection	18
Table 18: Component Value.....	18
Table 19: Typical Reflow Profile (Lead Free): J-STD-020C.....	23
Table 20: Ordering Information (Samples)	24
Table 21: Ordering Information (Production).....	24

Ultra-Low Power Wi-Fi + Bluetooth® LE Combo Module**1 References**

DA16600MOD consist of a DA16200 and a DA14531 chipset. Please see the respective chipset and module datasheets for details.

- [1] DA16200 Datasheet, Dialog Semiconductor
- [2] DA16200MOD Datasheet, Dialog Semiconductor
(available at <https://www.dialog-semiconductor.com/products/connectivity/wi-fi>)
- [3] DA14531, Datasheet, Dialog Semiconductor
- [4] DA14531MOD Datasheet, Dialog Semiconductor
(available at <https://www.dialog-semiconductor.com/products/connectivity/bluetooth-low-energy/products/da14530-and-da14531>)

Ultra-Low Power Wi-Fi + Bluetooth® LE Combo Module

2 Block Diagram

The DA16600 provides a high level of integration for a battery used wireless system, with integrated IEEE 802.11 b/g/n and Bluetooth V5.1. The DA16600 is designed to address the needs of battery used devices that require minimal power consumption and reliable operation.

Figure 1 shows the interconnection of all the physical blocks in DA16600MOD.

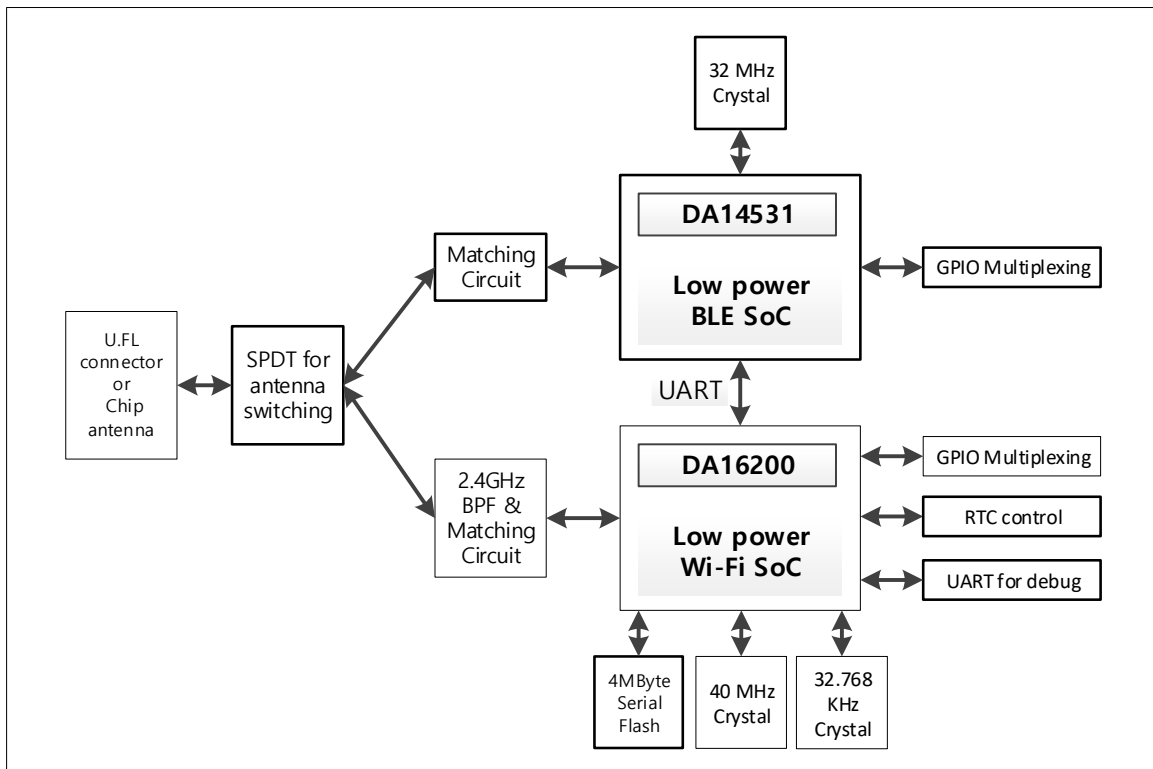

Figure 1: DA16600 Block Diagram

DA16600MOD Series

Ultra-Low Power Wi-Fi + Bluetooth® LE Combo Module

3 Pinout

3.1 Pinout Description (51-pins)

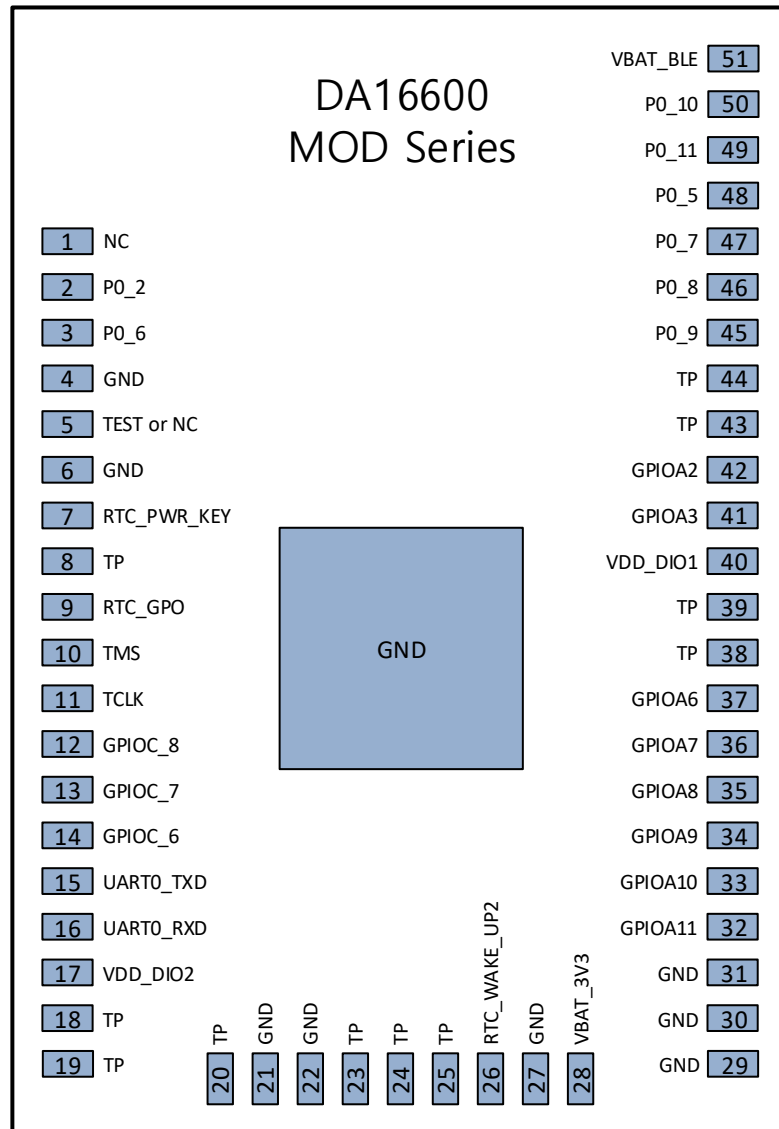

Figure 2: DA16600MOD 51-Pins Pinout Diagram (Top View)

Ultra-Low Power Wi-Fi + Bluetooth® LE Combo Module

Table 1: Pin Description

#Pin	Pin Name	Type	Drive(mA)	Reset State	Related Device	Description
1	NC	AI			DA14531	Not Connect
2	P0_2	DIO			DA14531	General Purpose I/O
3	P0_6	DIO			DA14531	Internally connected to RF switch Note 1
4	GND	GND			Common	Ground
5	TEST or NC	AI			Common	Chip antenna type: RF_Test u.FL connector type: NC
6	GND	GND			Common	Ground
7	RTC_PWR_KEY	DI			DA16200	RTC block enable signal
8	TP	DNC			DA16200	RTC block wake up signal is internally connected Note 1
9	RTC_GPO	DO			DA16200	Sensor control signal
10	TMS	DIO	2/4/8/12	I-PU	DA16200	JTAG I/F, SWDIO
11	TCLK	DIO	2/4/8/12	I-PD	DA16200	JTAG I/F, SWCLK, General Purpose I/O
12	GPIOC_8	DIO	2/4/8/12	I-PD	DA16200	General Purpose I/O
13	GPIOC_7	DIO	2/4/8/12	I-PD	DA16200	General Purpose I/O
14	GPIOC_6	DIO	2/4/8/12	I-PD	DA16200	General Purpose I/O
15	UART0_TXD	DO	2/4/8/12	O	DA16200	UART transmit data
16	UART0_RXD	DI	2/4/8/12	I	DA16200	UART receive data
17	VDD_DIO2	VDD			DA16200	Supply power for digital I/O GPIOC6~GPIOC8, TMS/TCLK, TXD/RXD
18	TP	DNC			DA16200	F_IO0 is internally connected to Flash Memory
19	TP	DNC			DA16200	F_CLK is internally connected to Flash Memory
20	TP	DNC			DA16200	F_IO3 is internally connected to Flash Memory
21	GND	GND			Common	Ground
22	GND	GND			Common	Ground
23	TP	DNC			DA16200	F_IO1 is internally connected to Flash Memory
24	TP	DNC			DA16200	F_CSN is internally connected to Flash Memory

Ultra-Low Power Wi-Fi + Bluetooth® LE Combo Module

#Pin	Pin Name	Type	Drive(mA)	Reset State	Related Device	Description
25	TP	DNC			DA16200	F_IO2 is internally connected to Flash Memory
26	RTC_WAKE_UP2	DI			DA16200	RTC block wake-up signal
27	GND	GND			Common	Ground
28	VBAT_3V3	VDD			DA16200	Supply power for internal DC-DC, DIO_LDO, and Analog IP of DA16200
29	GND	GND			Common	Ground
30	GND	GND			Common	Ground
31	GND	GND			Common	Ground
32	GPIOA11	DIO	2/4/8/12	I-PD	DA16200	General Purpose I/O
33	GPIOA10	DIO	2/4/8/12	I-PD	DA16200	General Purpose I/O
34	GPIOA9	DIO	2/4/8/12	I-PD	DA16200	General Purpose I/O
35	GPIOA8	DIO	2/4/8/12	I-PD	DA16200	General Purpose I/O
36	GPIOA7	DIO	2/4/8/12	I-PD	DA16200	General Purpose I/O
37	GPIOA6	DIO	2/4/8/12	I-PD	DA16200	General Purpose I/O
38	TP	DNC	2/4/8/12	I-PD	Common	GPIOA5 of DA16200 is internally connected to P0_3 of DA14531 Note 1
39	TP	DNC	2/4/8/12	I-PD	Common	GPIOA4 of DA16200 is internally connected to P0_4 of DA14531 Note 1
40	VDD_DIO1	VDD			DA16200	Supply power for digital I/O GPIOA0~GPIOA11
41	GPIOA3	AI/DIO	2/4/8/12	I-PD	DA16200	Aux. ADC input/General Purpose I/O
42	GPIOA2	AI/DIO	2/4/8/12	I-PD	DA16200	Aux. ADC input/General Purpose I/O
43	TP	DNC	2/4/8/12	I-PD	Common	GPIOA1 of DA16200 is internally connected to P0_0 of DA14531 Note 1
44	TP	DNC	2/4/8/12	I-PD	Common	GPIOA0 of DA16200 is internally connected to P0_1 of DA14531 Note 1
45	P0_9	DIO	3.5 / 0.3	I-PD	DA14531	General Purpose I/O
46	P0_8	DIO	3.5 / 0.3	I-PD	DA14531	General Purpose I/O
47	P0_7	DIO	3.5 / 0.3	I-PD	DA14531	General Purpose I/O
48	P0_5	DIO	3.5 / 0.3	I-PD	DA14531	General Purpose I/O
49	P0_11	DIO	3.5 / 0.3	I-PD	DA14531	General Purpose I/O
50	P0_10	DIO	3.5 / 0.3	I-PD	DA14531	General Purpose I/O
51	VBAT_BLE	VDD			DA14531	Supply power for DA14531

Ultra-Low Power Wi-Fi + Bluetooth® LE Combo Module

Note 1 Pin3, Pin8, Pin 38, Pin 39, Pin 43, and Pin 44 are connected internally so these pins can't be used as GPIO or as wake up input in application system.

3.2 Pin Multiplexing

This device provides various interfaces to support many kinds of applications.

In DA16200, it is possible to control each pin according to the required application in reference to the pin multiplexing illustrated in [Table 2](#) Pin control can be realized through register setting.

In DA14531, I/O pin assignment can be configured by the SW and is organized into the Port 0.

Please refer the datasheet and user manual of DA16200 and DA14531 respectively for detail information.

Table 2: DA16200 Pin Multiplexing

Pin	JTAG	Analog	SPI Master	SPI Slave	I2C Master	I2C Slave	BT Coex	I2S	I2S_Clock	UART2	Muxed w/Analog	Pin State (nRESET=0)	Driving Strength (Default : 8mA)
TP											Yes	I-PD	2/4/8/12mA
TP											Yes	I-PD	2/4/8/12mA
GPIOA2		CH2		SPI_CSB		I2C_SDA		SDO			Yes	I-PD	2/4/8/12mA
GPIOA3		CH3		SPI_CLK		I2C_CLK		LRCK	CLK_IN		Yes	I-PD	2/4/8/12mA
TP											No	I-PD	2/4/8/12mA
TP											No	I-PD	2/4/8/12mA
GPIOA6			SPI_CSB	SPI_CSB		I2C_SDA		SDO			No	I-PD	2/4/8/12mA
GPIOA7			SPI_CLK	SPI_CLK		I2C_CLK		LRCK			No	I-PD	2/4/8/12mA
GPIOA8			SPI_DIO0	SPI_MISO	I2C_SDA		BT_SIG0	BCLK			No	I-PD	2/4/8/12mA
GPIOA9			SPI_DIO1	SPI_MOSI	I2C_CLK		BT_SIG1	MCLK			No	I-PD	2/4/8/12mA
GPIOA10			SPI_DIO2	SPI_MISO			BT_SIG2		CLK_IN	TXD	No	I-PD	2/4/8/12mA
GPIOA11			SPI_DIO3	SPI_MOSI						RXD	No	I-PD	2/4/8/12mA
TCLK/GPIOA15	TCLK										No	I-PD	2/4/8/12mA
TMS	TMS										No	I-PU	2/4/8/12mA
UART_TXD											No	O	2/4/8/12mA
UART_RXD											No	I	2/4/8/12mA
GPIOC8	TDI										No	I-PD	2/4/8/12mA
GPIOC7	TDO									RXD	No	I-PD	2/4/8/12mA
GPIOC6	NTRST									TXD	No	I-PD	2/4/8/12mA

Several pins are internally connected in the module, so these pins can't be used as GPIO. These pins are described as TP (test point) except P0_6 in DA16600MOD. Because of internally used pins, several interfaces of DA16200 – SDIO, SDeMMC and UART1– are not possible on DA16600MOD.

- DA16200: GPIOA0, GPIOA1, GPIOA4, GPIOA5
- DA14531: P0_0, P0_1, P0_3, P0_4, P0_6

P0_6 of DA14531 is internally connected to RF switch and need to be connected externally to GPIO_A9 or GPIO_A10 of DA16200 for coexistence, so this pin can't be used as other purpose of GPIO too.

4 Electrical Specification

4.1 Absolute Maximum Ratings

Stresses beyond those listed under Absolute Maximum Ratings may cause permanent damage to the device. These are stress ratings only, so functional operation of the device at these or any other conditions beyond those indicated in the operational sections of the specification are not implied. Exposure to Absolute Maximum Rating conditions for extended periods may affect device reliability.

Table 3: Absolute Maximum Ratings

Parameter	#Pins	Min	Max	Units
VBAT_3V3	28	-0.1	3.9	V
VDD_DIO1	40	-0.1	3.9	V
VDD_DIO2	17	-0.1	3.9	V
VBAT_BLE	51	-0.1	3.6	V

4.2 Recommended Operating Conditions

Table 4: Recommended Operating Conditions

Parameter	#Pins	Min	Typ	Max	Units
VBAT_3V3	28	2.1		3.6	V
VDD_DIO1	40	1.62		3.6	V
VDD_DIO2	17	1.62		3.6	V
VBAT_BLE	51	1.8		3.3	V
Ambient operating temperature range (T _A)		-40		+85	°C

4.3 Electrical Characteristics

4.3.1 DC Parameters, 1.8 V IO

Table 5: DC Parameters, 1.8 V IO

Symbol	Parameter	Condition	Min	Typ	Max	Units
V _{IL}	Input Low Voltage	Guaranteed logic Low level Note 1	VSS		0.3 × DVDD	V
V _{IH}	Input High Voltage	Guaranteed logic High level	0.7 × DVDD		DVDD	V
V _{OL}	Output Low Voltage	DVDD=Min.	VSS		0.2 × DVDD	V
V _{OH}	Output High Voltage	DVDD=Min.	0.8 × DVDD		DVDD	V
R _{PU}	Pull-up Resistor	V _{PAD} =V _{IH} , DIO=Min.			32.4	kΩ
R _{PD}	Pull-down Resistor	V _{PAD} =V _{IL} , DIO=Min.			32.4	

Note 1 DVDD = 1.8V, VDD_DIO1, VDD_DIO2 Logic Level.

Ultra-Low Power Wi-Fi + Bluetooth® LE Combo Module
4.3.2 DC Parameters, 3.3 V IO
Table 6: DC Parameters, 3.3 V IO

Symbol	Parameter	Condition	Min	Typ	Max	Units
V _{IL}	Input Low Voltage	Guaranteed logic Low level Note 2	VSS		0.8	V
V _{IH}	Input High Voltage	Guaranteed logic High level	2.0		DVDD	V
V _{OL}	Output Low Voltage	DVDD=Min.	VSS		0.4	V
V _{OH}	Output High Voltage	DVDD=Min.	2.4		DVDD	V
R _{PU}	Pull-up Resistor	V _{PAD} =V _{IH} , DIO=Min.			19.4	kΩ
R _{PD}	Pull-down Resistor	V _{PAD} =V _{IL} , DIO=Min.			16.0	

Note 2 DVDD= 3.3 V, VDD_DIO1, VDD_DIO2 Logic Level.

4.3.3 DC Parameters for RTC Block

There are several control pins in RTC block.

Table 7: DC Parameters for RTC block, 3.3 V VBAT

Symbol	Parameter	Condition	Min	Typ	Max	Units
V _{IL}	Input Low Voltage	Guaranteed logic Low level	VSS		0.6	V
V _{IH}	Input High Voltage	Guaranteed logic High level	2.2		VBAT	V

(RTC block: RTC_PWR_KEY, RTC_WAKE_UP2)

Table 8: DC Parameters for RTC block, 2.1 V VBAT

Symbol	Parameter	Condition	Min	Typ	Max	Units
V _{IL}	Input Low Voltage	Guaranteed logic Low level	VSS		0.3	V
V _{IH}	Input High Voltage	Guaranteed logic High level	1.6		VBAT	V

(RTC block: RTC_PWR_KEY, RTC_WAKE_UP2)

Ultra-Low Power Wi-Fi + Bluetooth® LE Combo Module
4.4 Radio Characteristics
4.4.1 Wi-Fi Characteristics

- TA = +25 °C, VBAT = 3.3 V, CH1 (2412 MHz)

Table 9: Wi-Fi Receiver Characteristics

Parameter	Condition	Min	Typ	Max	Units
Sensitivity (8% PER for 11b rates, 10% PER for 11g/11n rates)	1 Mbps DSSS	-98.5	-97.5	-95.5	dBm
	2 Mbps DSSS	-94	-93	-91	
	11 Mbps CCK	-89	-88	-86	
	6 Mbps OFDM	-90	-89	-87	
	9 Mbps OFDM	-90	-89	-87	
	18 Mbps OFDM	-88	-87	-85	
	36 Mbps OFDM	-81	-80	-78	
	54 Mbps OFDM	-75	-74	-72	
	MCS0(GF)	-90	-89	-87	
	MCS7(GF)	-72	-71	-69	
Maximum input level (8% PER for 11b rates, 10% PER for 11g/11n rates)	802.11b	-4	0	0	
	802.11g	-10	-4	-3	

Table 10: Wi-Fi Transmitter Characteristics

Parameter	Condition	Min	Typ	Max	Units
Maximum Output Power measured form IEEE spectral mask and EVM	1 Mbps DSSS	15	18	19	dBm
	2 Mbps DSSS	15	18	19	
	5.5 Mbps CCK	15	18	19	
	11 Mbps CCK	15	18	19	
	6 Mbps OFDM	14	17	18	
	9 Mbps OFDM	14	17	18	
	12 Mbps OFDM	14	17	18	
	18 Mbps OFDM	14	17	18	
	24 Mbps OFDM	13	16	17	
	36 Mbps OFDM	13	16	17	
	48 Mbps OFDM	11.5	14.5	15.5	
	54 Mbps OFDM	10.5	13.5	14.5	
	MCS0 OFDM	14	17	18	
	MCS7 OFDM	10.5	13.5	14.5	
Transmit center frequency accuracy		-25		+25	ppm

Ultra-Low Power Wi-Fi + Bluetooth® LE Combo Module

4.4.2 Bluetooth® LE Characteristics

Table 11: Radio 1 Mb/s – AC Characteristics

Parameter	Description	Condition	Min	Typ	Max	Unit
P _{SENS_CLEAN}	sensitivity level	Dirty Transmitter disabled; DC-DC converter disabled; PER = 30.8 %; Note 1		-93		dBm
P _{SENS_EPKT}	sensitivity level	Extended packet size (255 octets) Note 1		-90		dBm

Note 1 Measured according to Bluetooth® Low Energy Test Specification RF-PHY.TS/5.1.0

4.5 Current Consumption

4.5.1 Wi-Fi Characteristics

TA = +25 °C, VBAT = 3.3 V, w/ CPU clock is 80 MHz.

Table 12: Current Consumption in Active State

Parameter	Condition		Min	Typ	Max	Units	
ACTIVE	TX	1 Mbps DSSS @ 18.0 dBm	260	280	320	mA	
		6 Mbps OFDM @ 17.0 dBm	240	260	300		
		54 Mbps OFDM @ 13.5 dBm	180	200	240		
		MCS7 @ 13.5 dBm	180	200	240		
	RX	No signal Note 1		25	29		51
		1 Mbps DSSS Note 1		26.5	30.5		53
		1 Mbps DSSS		27	37.5		54
		54 Mbps OFDM		29	38.5		54
		MCS7		29	38.5		54

Note 1 Low Power Mode & CPU clock 30 MHz.

TA = +25 °C, VBAT = 3.3 V

Table 13: Current Consumption in Low Power Operation

Parameter	Condition	Min	Typ	Max	Units
Low Power Operation	Sleep 1		5.2 Note 1		µA
	Sleep 2		6.8 Note 1		
	Sleep 3		8.5 Note 1		

Note 1 RF switch current consumption is included. VDD of RF switch is connected to VBAT_3V3 for DA16200 and typical current consumption of RF switch is 5 µA.

Ultra-Low Power Wi-Fi + Bluetooth® LE Combo Module

4.5.2 Bluetooth® LE Characteristics

Table 14: DC Characteristics

Parameter	Description	Conditions	Min	Typ	Max	Units
I _{BAT_ACTIVE}	Battery supply current			0.4		mA
I _{BAT_BLE_ADV_100ms}	Average battery supply current with system in Advertising state (3 channels) every 100ms and extended sleep with all RAM retained.			80		μA
I _{BAT_BLE_CONN_30ms}	Average battery supply current with system in a connection state with 30ms connection interval and extended sleep with all RAM retained.			92		μA
I _{BAT_HIBERN}	Battery supply current with system shut down			0.6		μA
I _{BAT_RF_RX}	Battery supply current	Continuous Rx		2.3		mA
I _{BAT_RF_TX_+2}	Battery supply current	Continuous Tx; Output power at 2dBm Note 1		4.3		mA
I _{BAT_RF_TX_-1}	Battery supply current	Continuous Tx; Output power at -1dBm Note 2		3.6		mA
I _{BAT_RF_TX_-4}	Battery supply current	Continuous Tx; Output power at -4dBm		2.8		mA

Note 1 All Bluetooth applications run on DA16200, so DA16200 should be active to handle Bluetooth data (e.g. Bluetooth Connection Request coming from a Bluetooth peer), in which case, Rx active current of DA16200 is added to the total current consumption.

Note 2 The actual Tx output power is slightly different than the one indicated in the parameter name.

4.6 Radiation Performance

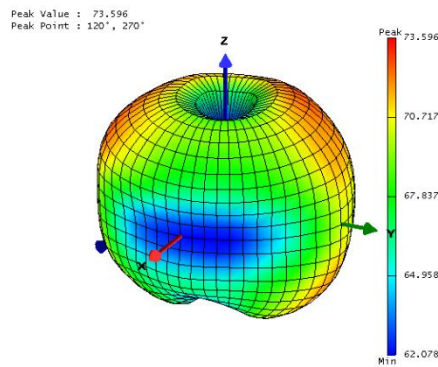

Figure 3: TIS 3D

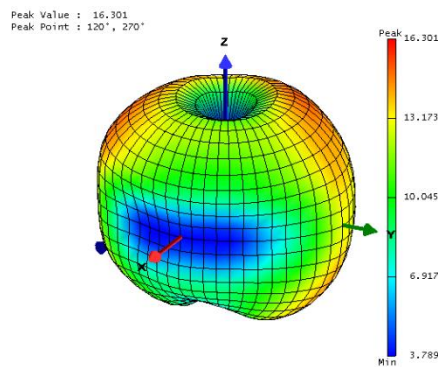

Figure 4: TRP 3D

4.7 ESD Ratings

Table 15: ESD Performance

Reliability Test	Standards	Test Conditions	Result
Human Body Model (HBM)	ANSI/ESDA/JEDEC JS-001-2017	± 2,000 V	Pass
Charge Device Mode (CDM)	ANSI/ESDA/JEDEC JS-002-2018	± 500 V	Pass

5 Power-on Sequence

The sequence after the initial switching from power-off to power-on of DA16200 is shown in Figure 5.

The RTC_PWR_KEY is a pin that enables the RTC block of DA16200. Once RTC_PWR_KEY is enabled after VBAT power is supplied, all the internal regulators are switched on automatically in the sequence pre-defined by the RTC block.

Once RTC_PWR_KEY is switched on, LDOs for both XTAL and digital I/O are switched on shortly and then the DC-DC regulator is switched on according to the pre-defined interval. The enabling intervals can also be modified in the register settings after initial power-up.

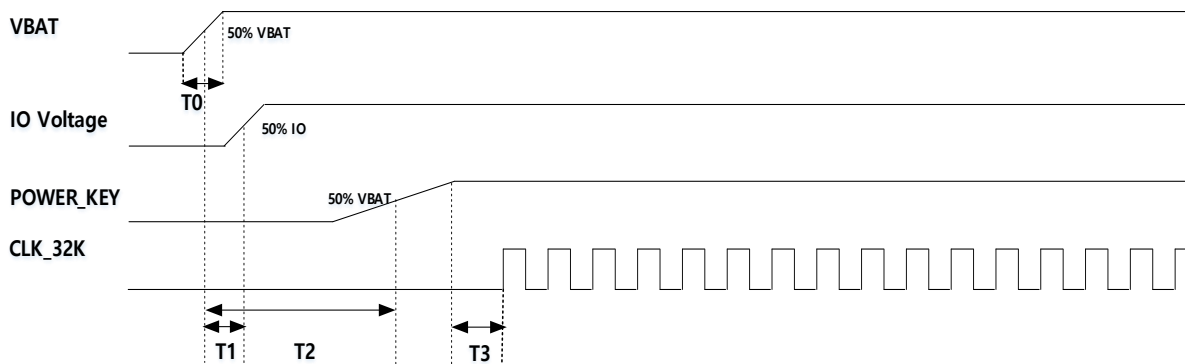

Figure 5: Power On Sequence

Table 16: Power On Sequence Timing Requirements

Name	Description	Min	Typ	Max	Unit
T0	VBAT power-on time from 10 % to 90 % of VBAT				ms
T1	IO voltage and VCC supply		0		ms
T2	RTC_PWR_KEY turn-on time from 50 % VBAT to 50 % POWER_KEY * Note 3		5*T0		ms
T3	Internal RC oscillator wake-up time		217		µs

Note 3 If the T0 = 10 ms to switch on VBAT, the recommended T2 is 50 ms for the safe booting operation. It would be externally controlled by MCU or it would be implemented using RC filter at the input of RTC_PWR_KEY. The recommended C is 470 nF or 1 uF (not to exceed 1 uF) and R value is chosen to have T2 delay. For example, R and C values will be 82 kΩ and 1uF when T0 = 10 ms.

6 Applications Schematic

6.1 Typical Application

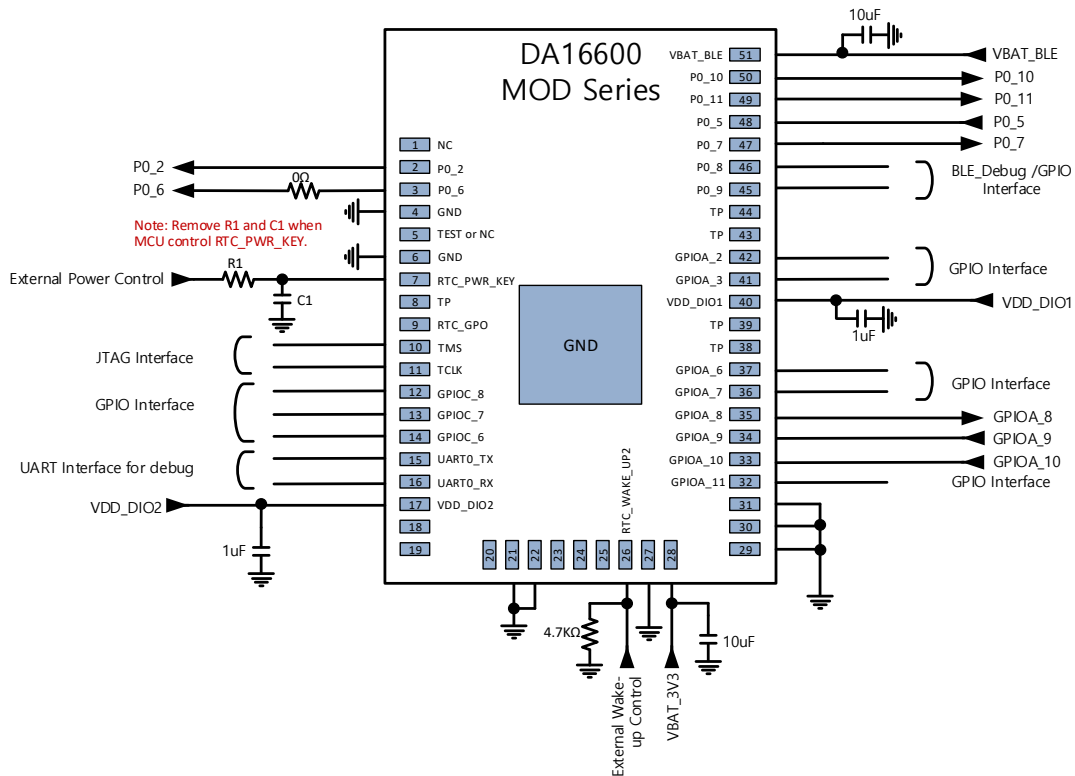

Figure 6: Typical Application

Table 17: Coexistence Connection

DA14531 part	DA16200 part	Function
P0_5	GPIOA_8	Wi-Fi_ACT
P0_6	GPIOA_9	BT_ACT
P0_7	GPIOA_10	BT_PRIOR

Table 18: Component Value

Part Reference	Value	Description
R1	470 kΩ	Remove R1 when MCU control 'RTC_PWR_KEY'. This value should be chosen by customer application to achieve the enough delay time depending on the power-on time of VBAT. For detail information, see Section 5.
C1	1 µF	Remove C1 when MCU control 'RTC_PWR_KEY'. This value should be chosen by customer application to achieve the enough delay time depending on the power-on time of VBAT. Not to exceed 1µF. For detail information, see Section 5.

DA16600MOD Series

Ultra-Low Power Wi-Fi + Bluetooth® LE Combo Module

7 Package Information

7.1 Dimension: DA16600MOD-AAC

Unit: millimeters (mm)

Tolerance : 14.3 (±0.2) x 24.3 (±0.2) x 3.0 (±0.1)

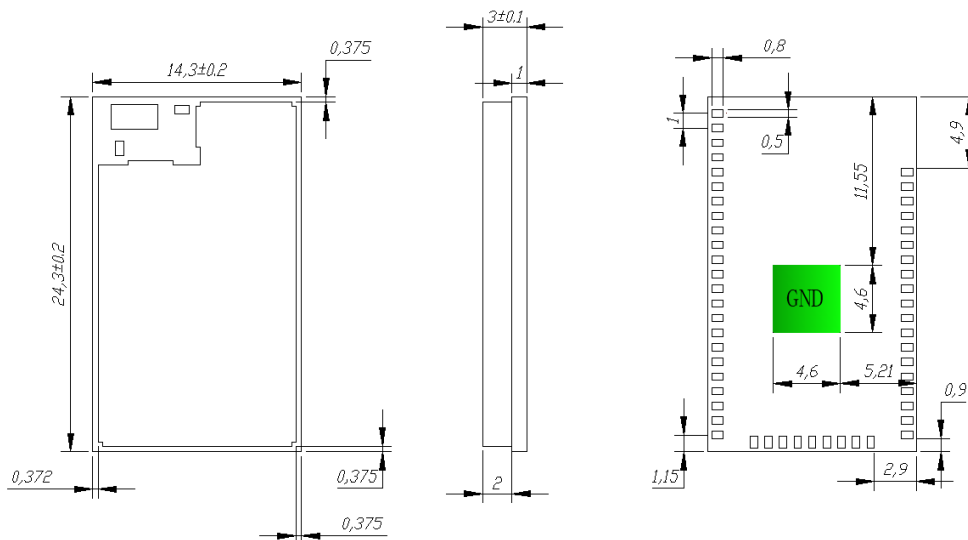

Figure 7: AAC Module Dimension

7.2 Dimension: DA16600MOD-AAE

Unit: millimeters (mm)

Tolerance : 14.3 (±0.2) x 24.3 (±0.2) x 3.0 (±0.1)

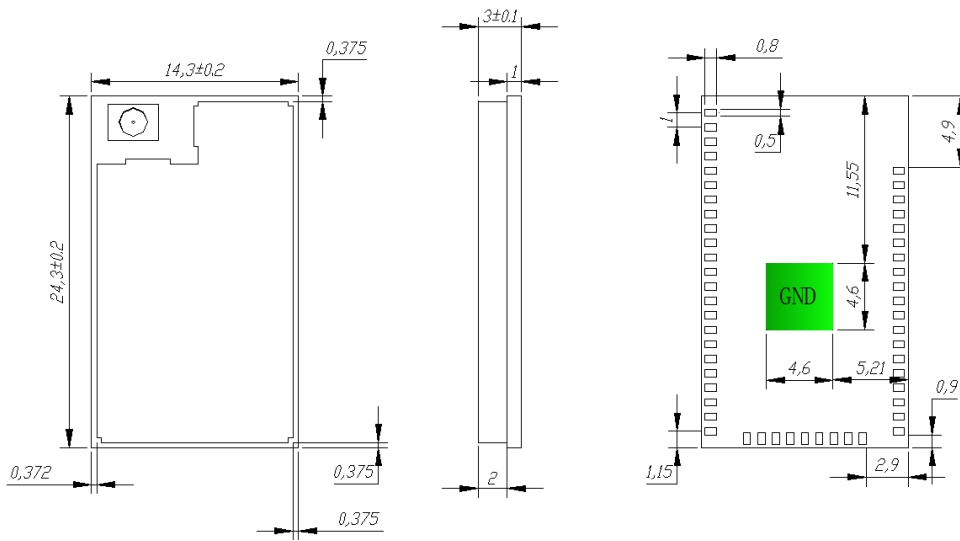

Figure 8: AAE Module Dimension

7.3 PCB Land Pattern

Unit: millimeters (mm)

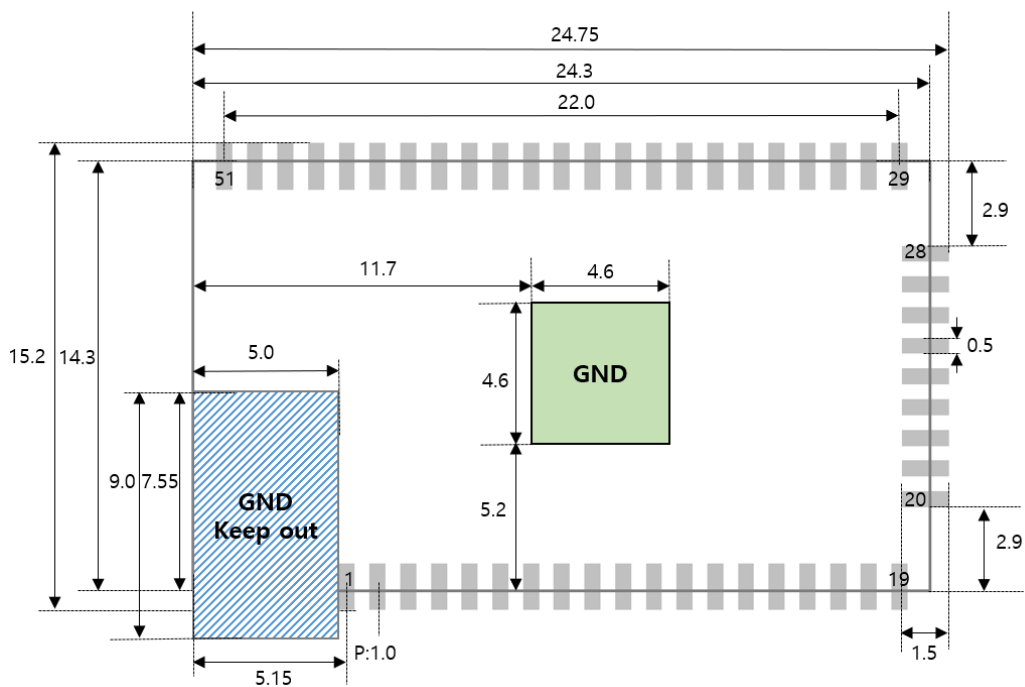

Figure 9: PCB Land Pattern (Top View)

7.4 4-layer PCB Example

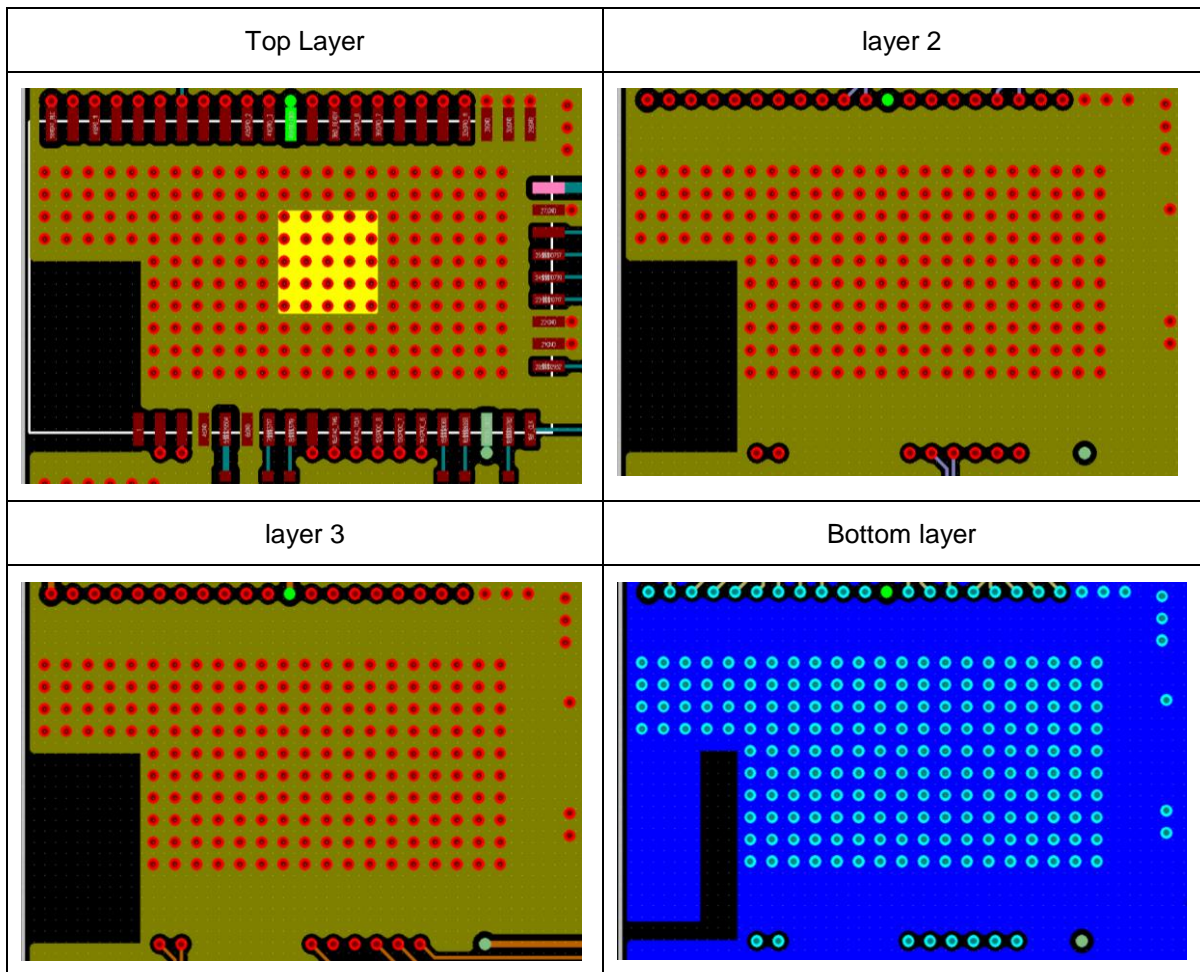

Figure 11: 4-Layer PCB Example

Ultra-Low Power Wi-Fi + Bluetooth® LE Combo Module

7.5 Soldering Information

7.5.1 Recommended Condition for Reflow Soldering

The reflow profile depends on the solder paste being used and the recommendations from the paste manufacturer should be followed to determine the proper reflow profile.

Table 19: Typical Reflow Profile (Lead Free): J-STD-020C

Profile Feature	Lead Free SMD
Average ramp up rate (T_{Smax} to T_p)	3 °C/s Max.
Preheat	
<ul style="list-style-type: none"> Temperature Min (T_{Smin}) Temperature Max (T_{Smax}) Time (T_{Smax} to T_{Smin}) 	<ul style="list-style-type: none"> 150 °C 200 °C 60 to 180 seconds
Time maintained above	
<ul style="list-style-type: none"> Temperature (T_L) Time (t_L) 	<ul style="list-style-type: none"> 217 °C 60 to 150 seconds
Peak/Classification temperature (T_p)	260 °C
Time within 5 °C of peak temperature (t_p)	20 to 40 seconds
Ramp down rate	6 °C/s Max.
Time from 25 °C to peak temperature	8 minutes Max.

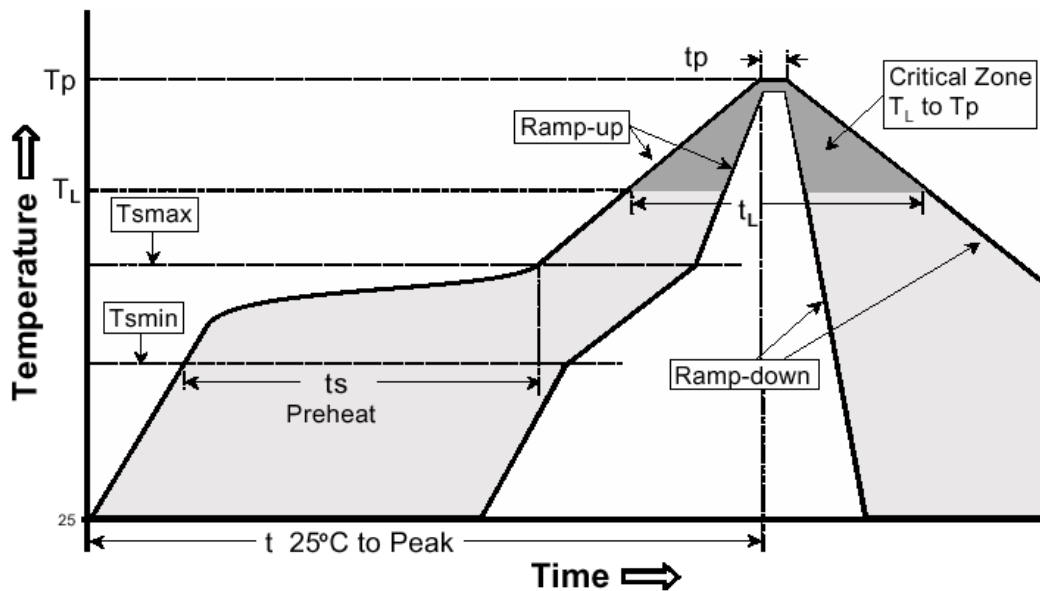

Figure 12: Reflow Condition

Ultra-Low Power Wi-Fi + Bluetooth® LE Combo Module

8 Ordering Information

The order number consists of the part number followed by a suffix that indicates the packing method. For details and availability, please consult Dialog Semiconductor's website at <https://www.dialog-semiconductor.com/products/da16600-modules> or your local sales representative.

Table 20: Ordering Information (Samples)

Part Number	Pins	Size (mm)	Shipment Form	Pack Quantity
DA16600MOD-AAC4WA32	51	14.3 x 24.3 x 3.0	Reel	
DA16600MOD-AAE4WA32	51	14.3 x 24.3 x 3.0	Reel	

Table 21: Ordering Information (Production)

Part Number	Pins	Size (mm)	Shipment Form	Pack Quantity
DA16600MOD-AAC4WA32	51	14.3 x 24.3 x 3.0	Reel	500
DA16600MOD-AAE4WA32	51	14.3 x 24.3 x 3.0	Reel	500

Part Number Legend:

DA16600MOD-AAC4WA32

AA: Module revision number

C: Select module type

[C] Chip antenna, [E] u.FL connector

4: Flash memory

[4] 4Mbyte, [2] 2 Mbyte

W: Voltage range

[W] 3.3 V, [L] 1.8 V

A3: Package No.

2: T&R packing

Ultra-Low Power Wi-Fi + Bluetooth® LE Combo Module

Revision History

Revision	Date	Description
3.0	23-Feb-2020	Official release
1.4	26-Oct-2020	Modified application schematic
1.3	15-July-2020	Modified application schematic
1.2	22-May-2020	Added ESD performance, Table 15
1.1	29-April-2020	Preliminary datasheet

Ultra-Low Power Wi-Fi + Bluetooth® LE Combo Module

Status Definitions

Revision	Datasheet Status	Product Status	Definition
1.<n>	Target	Development	This datasheet contains the design specifications for product development. Specifications may be changed in any manner without notice.
2.<n>	Preliminary	Qualification	This datasheet contains the specifications and preliminary characterization data for products in pre-production. Specifications may be changed at any time without notice in order to improve the design.
3.<n>	Final	Production	This datasheet contains the final specifications for products in volume production. The specifications may be changed at any time in order to improve the design, manufacturing and supply. Major specification changes are communicated via Customer Product Notifications. Datasheet changes are communicated via www.dialog-semiconductor.com .
4.<n>	Obsolete	Archived	This datasheet contains the specifications for discontinued products. The information is provided for reference only.

Disclaimer

Unless otherwise agreed in writing, the Dialog Semiconductor products (and any associated software) referred to in this document are not designed, authorized or warranted to be suitable for use in life support, life-critical or safety-critical systems or equipment, nor in applications where failure or malfunction of a Dialog Semiconductor product (or associated software) can reasonably be expected to result in personal injury, death or severe property or environmental damage. Dialog Semiconductor and its suppliers accept no liability for inclusion and/or use of Dialog Semiconductor products (and any associated software) in such equipment or applications and therefore such inclusion and/or use is at the customer's own risk.

Information in this document is believed to be accurate and reliable. However, Dialog Semiconductor does not give any representations or warranties, express or implied, as to the accuracy or completeness of such information. Dialog Semiconductor furthermore takes no responsibility whatsoever for the content in this document if provided by any information source outside of Dialog Semiconductor.

Dialog Semiconductor reserves the right to change without notice the information published in this document, including, without limitation, the specification and the design of the related semiconductor products, software and applications. Notwithstanding the foregoing, for any automotive grade version of the device, Dialog Semiconductor reserves the right to change the information published in this document, including, without limitation, the specification and the design of the related semiconductor products, software and applications, in accordance with its standard automotive change notification process.

Applications, software, and semiconductor products described in this document are for illustrative purposes only. Dialog Semiconductor makes no representation or warranty that such applications, software and semiconductor products will be suitable for the specified use without further testing or modification. Unless otherwise agreed in writing, such testing or modification is the sole responsibility of the customer and Dialog Semiconductor excludes all liability in this respect.

Nothing in this document may be construed as a license for customer to use the Dialog Semiconductor products, software and applications referred to in this document. Such license must be separately sought by customer with Dialog Semiconductor.

All use of Dialog Semiconductor products, software and applications referred to in this document is subject to Dialog Semiconductor's [Standard Terms and Conditions of Sale](http://www.dialog-semiconductor.com), available on the company website (www.dialog-semiconductor.com) unless otherwise stated.

Dialog, Dialog Semiconductor and the Dialog logo are trademarks of Dialog Semiconductor Plc or its subsidiaries. All other product or service names and marks are the property of their respective owners.

© 2021 Dialog Semiconductor. All rights reserved.

Reach and RoHS Compliance

Dialog Semiconductor's suppliers certify that its products are in compliance with the requirements of REACH and Directive 2015/863/EU of the European Parliament on the restriction of the use of certain hazardous substances in electrical and electronic equipment. RoHS certificates from our suppliers are available on request. Module doesn't have to be HF.

Contacting Dialog Semiconductor

United Kingdom (Headquarters)

Dialog Semiconductor (UK) LTD
Phone: +44 1793 757700

Germany

Dialog Semiconductor GmbH
Phone: +49 7021 805-0

The Netherlands

Dialog Semiconductor B.V.
Phone: +31 73 640 8822

Email:

enquiry@diasemi.com

North America

Dialog Semiconductor Inc.
Phone: +1 408 845 8500

Japan

Dialog Semiconductor K. K.
Phone: +81 3 5769 5100

Taiwan

Dialog Semiconductor Taiwan
Phone: +886 281 786 222

Web site:

www.dialog-semiconductor.com

Hong Kong

Dialog Semiconductor Hong Kong
Phone: +852 2607 4271

Korea

Dialog Semiconductor Korea
Phone: +82 2 3469 8200

China (Shenzhen)

Dialog Semiconductor China
Phone: +86 755 2981 3669

China (Shanghai)

Dialog Semiconductor China
Phone: +86 21 5424 9058