

Contents

1 Features	3
2 Order Codes	5
3 Mechanical and Electrical Interfacing	6
3.1 Size of the board	6
4 Connectors	7
5 Reset to Factory Defaults	10
6 I/Os	12
6.1 Analog input IN0	12
6.2 Digital inputs IN2 and IN3	12
6.3 Digital output OUT0	12
6.4 HOME/STOP_L/STOP_R switch inputs	12
6.5 External incremental encoder input	12
6.6 Step/Direction inputs	12
6.7 Address pins	12
7 Communication	14
7.1 RS485	14
7.2 CAN	15
8 Functional Description	17
9 Operational Ratings and Characteristics	18
10 Abbreviations used in this Manual	20
11 Figures Index	21
12 Tables Index	22
13 Supplemental Directives	23
13.1 Producer Information	23
13.2 Copyright	23
13.3 Trademark Designations and Symbols	23
13.4 Target User	23
13.5 Disclaimer: Life Support Systems	23
13.6 Disclaimer: Intended Use	23
13.7 Collateral Documents & Tools	24
14 Revision History	25
14.1 Hardware Revision	25
14.2 Document Revision	25



1 Features

The TMCM-1231 is a single axis motor controller/driver board for 2-phase bipolar stepper motors with up to 5A RMS (7A peak) motor coil current. It supports linear ramps, SixPoint™ ramps and S-shaped ramps. Incremental ABN encoders are also supported. For driver-only applications, the TMCM-1231 offers Step/Direction inputs. The TMCM-1231 is also equipped with two analog inputs (0...5V range), two digital inputs and two digital (TTL level) outputs. For communication, RS485 and CAN bus interfaces are available. With CANopen firmware CANopen protocol is supported via the CAN interface.

Motion Controller

- Motion profile calculation in real-time.
- On the fly alteration of motor parameters (e.g. position, velocity, acceleration).
- Linear, SixPoint™ and S-shaped ramps in hardware.
- Encoder interface.
- Home switch and stop switch inputs.

Driver

- Motor current: up to 6.5A RMS (9.2A peak, programmable in software).
- Motor supply voltage: +24V or +48V DC (+10... +52V DC).
- Logic supply voltage: +5V DC.
- 256 microsteps per fullstep.
- spreadCycle™ highly dynamic current control chopper.
- stealthChop™ for quiet operation and smooth motion.
- programmable Step/Dir interface for driver-only applications with microstep interpolation .

Encoder

- Input for ABN incremental encoder.
- Programmable encoder scaling and support for motor stop on encoder deviation.

Interfaces

- RS485 interface (up to 1Mbit/s).
- CAN interface (up to 1Mbit/s).
- Step/Dir input.
- Left and Right stop switch inputs.
- Two general purpose digital inputs.
- Encoder input for incremental ABN encoder signals.
- Two analog inputs (0...5V input range).
- Home switch input.

Mechanical data

- Board size: 80mm x 40/45mm, height 7mm max.



- 98-pin slot type connector

Software

- TMCL™ remote (direct mode) and standalone operation (memory for up to 2047 TMCL™ commands), fully supported by TMCL-IDE (PC based integrated development environment). Please see TMCM-1231 TMCL firmware manual for more details.
- CANopen firmware with CANopen standard protocol stack for the CAN interface. Please see TMCM-1231 CANopen firmware manual for more details.



2 Order Codes

The standard version of the TMCM-1231 is pre-programmed with either TRINAMIC TMCL™ firmware or CANopen firmware.

Order Code	Description	Size
TMCM-1231-TMCL	1-axis bipolar stepper motor controller/driver, up to 5A RMS motor current, 24V nom. supply, ABN encoder input, S/D input, stop/home switch inputs, 2 analog inputs , 2 digital inputs, 2 digital outputs, CAN and RS485 interfaces	80mm x 40mm (connector: 45mm)
TMCM-1231-CANopen	1-axis bipolar stepper motor controller/driver, up to 5A RMS motor current, 24V nom. supply, ABN encoder input, S/D input, stop/home switch inputs, 2 analog inputs , 2 digital inputs, 2 digital outputs, CAN and RS485 interfaces	80mm x 40mm (connector: 45mm)

Table 1: TMCM-1231 Order Codes



3 Mechanical and Electrical Interfacing

3.1 Size of the board

The board has an overall size of 80mm x 40mm without the connector. Together with the slot type connector the board size is 80mm x 45mm. The thickness of the board with components is max. 7mm. There is one 5mm diameter mounting hole.

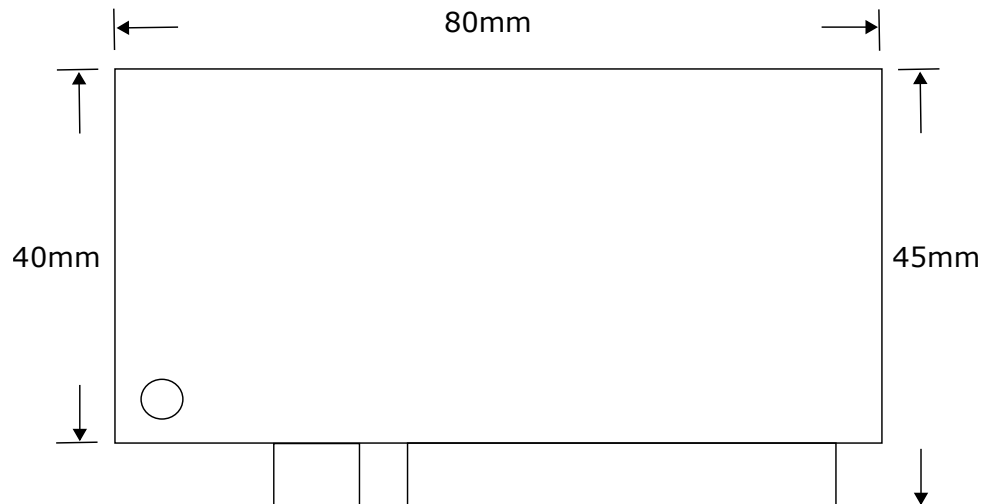

Figure 1: Board dimensions, position of mounting holes and position (pin 1) of connectors (all values in mm)



4 Connectors

The TMCM-1231 is equipped with an 98-pin slot type connector. As a mating connector on base boards an 98-pin PCIe slot can be used (but please do not try to plug the module into the PCIe slot of a PC main board). All signals of the module are routed via the slot type connector. These are the supply voltages, the CAN and RS485 interface, motor coils, encoder inputs and all other signals needed by the module. The pins located on the top side of the module PCB are labelled B1...B48 and the pins located on the bottom side of the PCB are labelled A1...A48.

For trying out the TMCM-1231 for the first time we recommend using a Trinamic base board. But a base board can also be designed by the user.

NOTICE

Start with power supply OFF and do not connect or disconnect motor during operation! Motor cable and motor inductivity might lead to voltage spikes when the motor is (dis)connected while energized. These voltage spikes might exceed voltage limits of the driver MOSFETs and might permanently damage them. Therefore, always switch off / disconnect power supply or at least disable driver stage before connecting / disconnecting motor.

Slot Type Connector Pin Assignment (PCB Top Side)			
Pin	Label	Direction	Description
B1	+48V	input	Motor supply voltage
B2	+48V	input	Motor supply voltage
B3	+48V	input	Motor supply voltage
B4	+48V	input	Motor supply voltage
B5	GND	—	Power and signal ground
B6	GND	—	Power and signal ground
B7	GND	—	Power and signal ground
B8	GND	—	Power and signal ground
B9	NC	—	not connected
B10	NC	—	not connected
B11	NC	—	not connected
B12	OA2	output	Motor coil A pin 2
B13	OA2	output	Motor coil A pin 2
B14	OA2	output	Motor coil A pin 2
B15	OA2	output	Motor coil A pin 2
B16	OA1	output	Motor coil A pin 1
B17	OA1	output	Motor coil A pin 1
B18	OA1	output	Motor coil A pin 1
B19	OA1	output	Motor coil A pin 1
B20	OB2	output	Motor coil B pin 2



Pin	Label	Direction	Description
B21	OB2	output	Motor coil B pin 2
B22	OB2	output	Motor coil B pin 2
B23	OB2	output	Motor coil B pin 2
B24	OB1	output	Motor coil B pin 1
B25	OB1	output	Motor coil B pin 1
B26	OB1	output	Motor coil B pin 1
B27	OB1	output	Motor coil B pin 1
B28	NC		not connected
B29	GND	—	Power and signal ground
B30	NC	—	not connected
B31	NC	—	not connected
B32	NC	—	not connected
B33	GND	—	Power and signal ground
B34	SYNC	input	Synchronization signal input
B35	IRQ	output	Interrupt output
B36	ENABLE	input	Motor coil enable input
B37	GND	—	Power and signal ground
B38	IN3	input	General purpose digital input #3
B39	IN2	input	General purpose digital input #2
B40	GND	—	Power and signal ground
B41	NC	—	not connected #1
B42	OUT0	output	General purpose digital output #0
B43	GND	—	Power and signal ground
B44	RS485_A	in/out	RS485+ (non-inverted) signal
B45	RS485_B	in/out	RS485- (inverted) signal
B46	CAN_L	in/out	CAN bus low
B47	CAN_H	in/out	CAN bus high
B48	GND	—	Power and signal ground
B49	+5V	input	Logic supply voltage

Table 2: Top Side Slot Connector Pin Assignment



Slot Type Connector Pin Assignment (PCB Bottom Side)			
Pin	Label	Direction	Description
A1	+48V	input	Motor supply voltage
A2	+48V	input	Motor supply voltage
A3	+48V	input	Motor supply voltage
A4	+48V	input	Motor supply voltage
A5	GND	—	Power and signal ground
A6	GND	—	Power and signal ground
A7	GND	—	Power and signal ground
A8	GND	—	Power and signal ground
A9	NC	—	Not connected
A10	NC	—	Not connected
A11	NC	—	Not connected
A12	OA2	output	Motor coil A pin 2
A13	OA2	output	Motor coil A pin 2
A14	OA2	output	Motor coil A pin 2
A15	OA2	output	Motor coil A pin 2
A16	OA1	output	Motor coil A pin 1
A17	OA1	output	Motor coil A pin 1
A18	OA1	output	Motor coil A pin 1
A19	OA1	output	Motor coil A pin 1
A20	OB2	output	Motor coil B pin 2
A21	OB2	output	Motor coil B pin 2
A22	OB2	output	Motor coil B pin 2
A23	OB2	output	Motor coil B pin 2
A24	OB1	output	Motor coil B pin 1
A25	OB1	output	Motor coil B pin 1
A26	OB1	output	Motor coil B pin 1
A27	OB1	output	Motor coil B pin 1
A28	NC		not connected
A29	GND	—	Power and signal ground
A30	ENC_A	input	Encoder signal A (A channel)
A31	ENC_B	input	Encoder signal B (B channel)
A32	ENC_N	input	Encoder signal N (null channel)
A33	GND	—	Power and signal ground



Pin	Label	Direction	Description
A34	STOP_L	input	Left stop switch
A35	STOP_R	input	Right stop switch
A36	HOME	input	Home switch
A37	GND	—	Power and signal ground
A38	DIR	input	direction signal input
A39	STEP	input	step signal input
A40	GND	—	Power and signal ground
A41	NC	—	not connected
A42	AIN0	input	General purpose analog/digital input
A43	GND	—	Power and signal ground
A44	ADDR3	input	Module address bit 3
A45	ADDR2	input	Module address bit 2
A46	ADDR1	input	Module address bit 1
A47	ADDR0	input	Module address bit 0
A48	GND	—	Power and signal ground
A49	+5V	input	Logic supply voltage

Table 3: Bottom Side Slot Connector Pin Assignment

NOTICE

Do not connect or disconnect a motor during operation! Motor cable and motor inductivity might lead to voltage spikes when the motor is (dis)connected while energized. These voltage spikes might exceed voltage limits of the driver MOSFETs and might permanently damage them. Therefore, always switch off / disconnect power supply or at least disable driver stage before connecting / disconnecting motor.

NOTICE

Do not remove or plug in the module while the base board is powered!

5 Reset to Factory Defaults

It is possible to reset all settings in firmware for the TMC-1231 to factory defaults without establishing a working communication connection. This might be helpful in case communication parameters of the preferred interface have been set to unknown values or got lost.

For this procedure two pads on the top side of the module have to be shorted (electrically connected with each other) during power-on.

Please perform the following steps:

1. Switch power supply OFF.
2. Short CLK and DIO pads of programming pads on bottom of pcb (see figure 2).
3. Switch power supply ON again.



4. Wait a few seconds.
5. Switch power supply OFF again.
6. Remove the short between the two pads.
7. After switching power supply ON again all permanent settings have been restored to factory defaults.

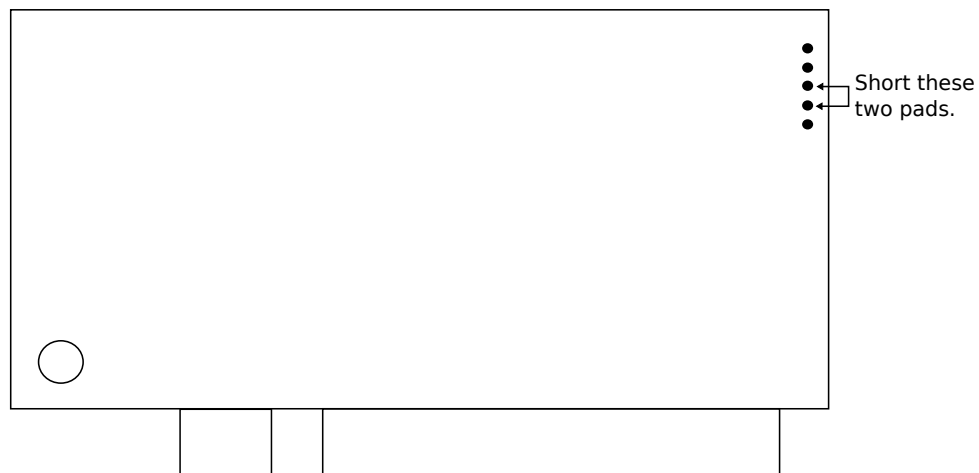

Figure 2: Reset to factory default settings

6 I/Os

The slot connector offers two analog inputs, two digital inputs and digital outputs. All inputs can be used for different purposes explained in more detail in the following subsections.

6.1 Analog input IN0

The TMCM-1231 is equipped with one analog input. The analog input voltage range is approx. 0...+5V. For voltages above +5V saturation takes place, but up-to 30V higher voltages are tolerated without destroying the input. For analog to digital conversion the integrated ADC of the on-board microcontroller is used. Resolution of this converter is 12bit (0..4095).

The analog input can also be used as a digital input.

6.2 Digital inputs IN2 and IN3

The TMCM-1231 offers two digital inputs IN2 and IN3. Their input voltage range is 0...+5V. Higher voltages (up to 30V) are also tolerated without destroying the input. Voltages above 1V are recognized as logical '1' and below 1V as logical '0'.

6.3 Digital output OUT0

The TMCM-1231 is equipped with one digital output OUT0. It is a 5V level TTL output.

6.4 HOME/STOP_L/STOP_R switch inputs

The TMCM-1231 offers two inputs which can be used as left (STOP_L) and right (STOP_R) stop switch inputs. When enabled in software the STOP_L switch input will stop motor movement in negative direction (step counter decreasing) while activated. Likewise the STOP_R switch input will stop motor movement in positive direction (step counter increasing) while activated.

6.5 External incremental encoder input

An external incremental A/B/N encoder may be connected to the encoder interface ENC_A, ENC_B and ENC_N. Encoder with push-pull signals (e.g. +5V TTL) and open-drain output signals are supported (single-ended). Add external pull-up resistors (to +5V) when using encoders with open-drain outputs.

6.6 Step/Direction inputs

The TMCM-1231 may be used as driver with an external motion controller. In this case the Step/Direction output signals of the external motion controller may be connected to the Step/Dir inputs of the TMCM-1231. Please note that these signals have to be TTL level signals.

6.7 Address pins

The address pins ADDR0, ADDR1, ADDR2 and ADDR3 can be used to set the TMCL module address or CANopen node ID of the TMCM-1231. This is useful when a base board with more than one slot is being used. In this case, every slot can be assigned to one specific TMCL module address or CANopen node ID by hardware.

When all address pins are pulled low, the address pins are not used. The TMCL module address or CANopen node ID stored in the EEPROM of the module will be used then. So in this case address / ID



settings will be set in software.

When at least one of the address pins is pulled high the address or ID set by the address pins will be used. With TMCL, the module address will be determined by the address pins (1...15), and the reply address will always be 255. This is true for CAN and for RS485 communication. With CANopen, the node ID will be determined by the address pins (1...15).



7 Communication

7.1 RS485

For remote control and communication with a host system the TMCM-1231 provides a two wire RS485 bus interface. For proper operation the following items should be taken into account when setting up an RS485 network:

1. **BUS STRUCTURE:**

The network topology should follow a bus structure as closely as possible. That is, the connection between each node and the bus itself should be as short as possible. Basically, it should be short compared to the length of the bus.

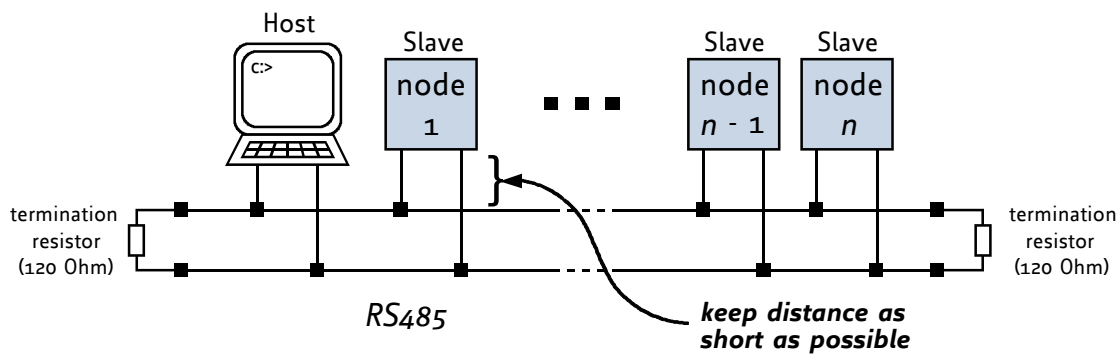

Figure 3: RS485 bus structure with termination resistors

2. **BUS TERMINATION:**

Especially for longer busses and/or multiple nodes connected to the bus and/or high communication speeds, the bus should be properly terminated at both ends. The TMCM-1231 does not integrate any termination resistor. Therefore, 120 Ohm termination resistors at both ends of the bus have to be added externally.

3. **NUMBER OF NODES:**

The RS485 electrical interface standard (EIA-485) allows up to 32 nodes to be connected to a single bus. The bus transceiver used on the TMCM-1231 units (SN65HVD1781D) offers a significantly reduced bus load compared to the standard and allows a maximum of 255 units to be connected to a single RS485 bus using standard TMCL firmware. *Please note: usually it cannot be expected to get reliable communication with the maximum number of nodes connected to one bus and maximum supported communication speed at the same time. Instead, a compromise has to be found between bus cable length, communication speed and number of nodes.*

4. **COMMUNICATION SPEED:**

The maximum RS485 communication speed supported by the TMCM-1231 hardware is 1Mbit/s. Factory default is 9600 bit/s. Please see separate TMCM-1231 TMCL firmware manual for information regarding other possible communication speeds below the upper hardware limit.

5. **NO FLOATING BUS LINES:**

Avoid floating bus lines while neither the host/master nor one of the slaves along the bus line is transmitting data (all bus nodes switched to receive mode). Floating bus lines may lead to communication errors. In order to ensure valid signals on the bus it is recommended to use a resistor network connecting both bus lines to well defined logic levels.

There are actually two options which can be recommended: Add resistor (bias) network on one side of the bus, only (120R termination resistor still at both ends):



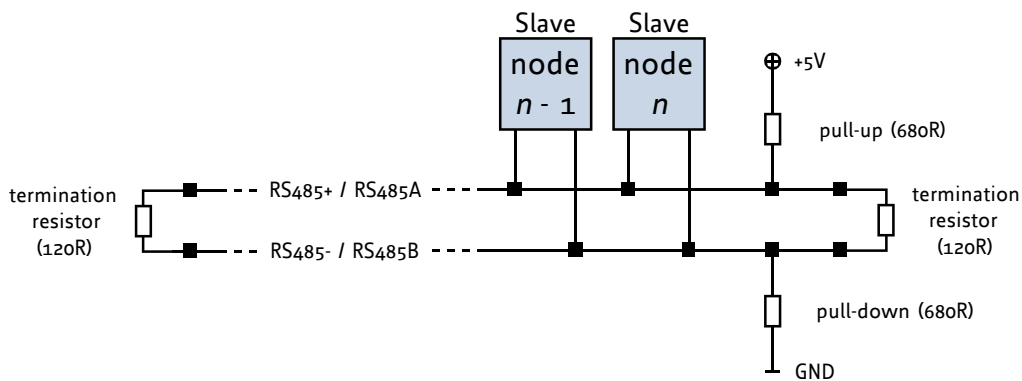

Figure 4: RS485 bus lines with resistor (bias) network on one side, only

Or add resistor network at both ends of the bus (like Profibus™ termination):

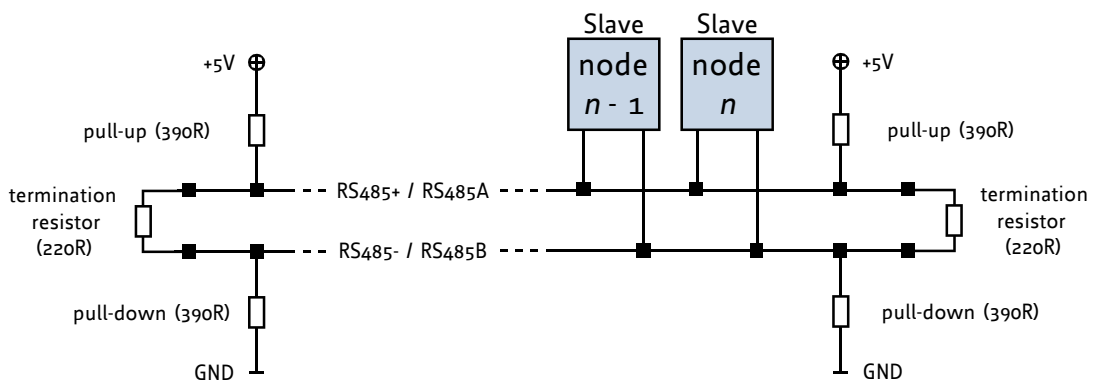

Figure 5: RS485 bus lines with Profibus™ recommended line termination

7.2 CAN

For remote control and communication with a host system the TMCM-1231 provides a CAN bus interface. Please note that the CAN interface is not available in case USB is connected. For proper operation the following items should be taken into account when setting up a CAN network:

1. BUS STRUCTURE:

The network topology should follow a bus structure as closely as possible. That is, the connection between each node and the bus itself should be as short as possible. Basically, it should be short compared to the length of the bus.



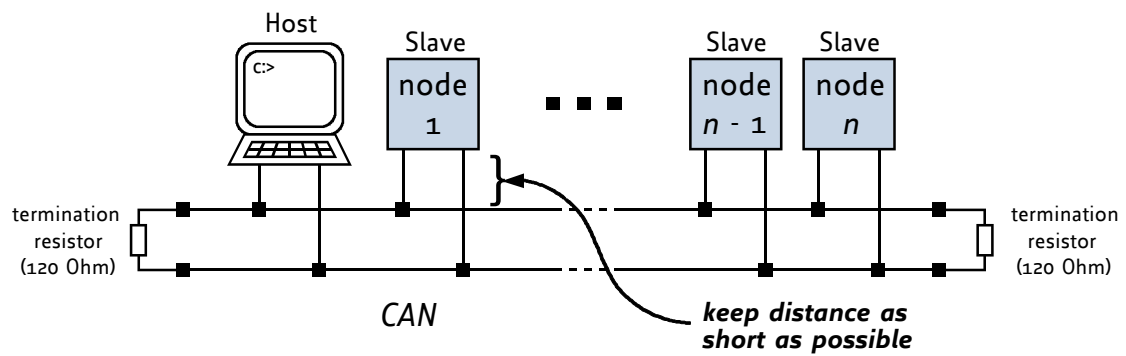

Figure 6: CAN bus structure with termination resistors

2. **BUS TERMINATION:**

Especially for longer busses and/or multiple nodes connected to the bus and/or high communication speeds, the bus should be properly terminated at both ends. The TMCM-1231 does not integrate any termination resistor. Therefore, 120 Ohm termination resistors at both ends of the bus have to be added externally.

3. **BUS TERMINATION:**

The bus transceiver used on the TMCM-1231 units (TJA1051T) supports at least 110 nodes under optimum conditions. Practically achievable number of nodes per CAN bus highly depend on bus length (longer bus -> less nodes) and communication speed (higher speed -> less nodes).



8 Functional Description

The TMCM-1231 is a highly integrated single axis controller/driver module for stepper motors with up-to 7A RMS / 10A peak motor coil current. The TMCM-1231 can be controlled via RS485 or CAN interface. The TMCM-1231 comes with the PC based software development environment TMCL-IDE for the Trinamic Motion Control Language (TMCL™). Using predefined TMCL™ high level commands like *move to position* a rapid and fast development of motion control applications is guaranteed. Whereas the boot loader is installed during production and testing at TRINAMIC and remains usually untouched throughout the whole lifetime, the firmware can be updated by the user via any serial interface. Communication traffic is kept low since all time critical operations, e.g. ramp calculation, are performed on-board. Full remote control of the device with feedback is possible. The firmware of the module can be updated via any of the serial interfaces.

The TMCM-1231 module contains the following main components:

- Microcontroller (ARM Cortex-M0+™), responsible for overall control and communication
- Highly integrated advanced stepper motor controller supporting linear, SixPoint™ and S-shaped ramps in hardware.
- Advanced stepper motor driver with stallGuard2™ and coolStep™ with MOSFET driver stage (8x power N-MOSFETs for bipolar stepper motor).
- RS485 and CAN transceivers.

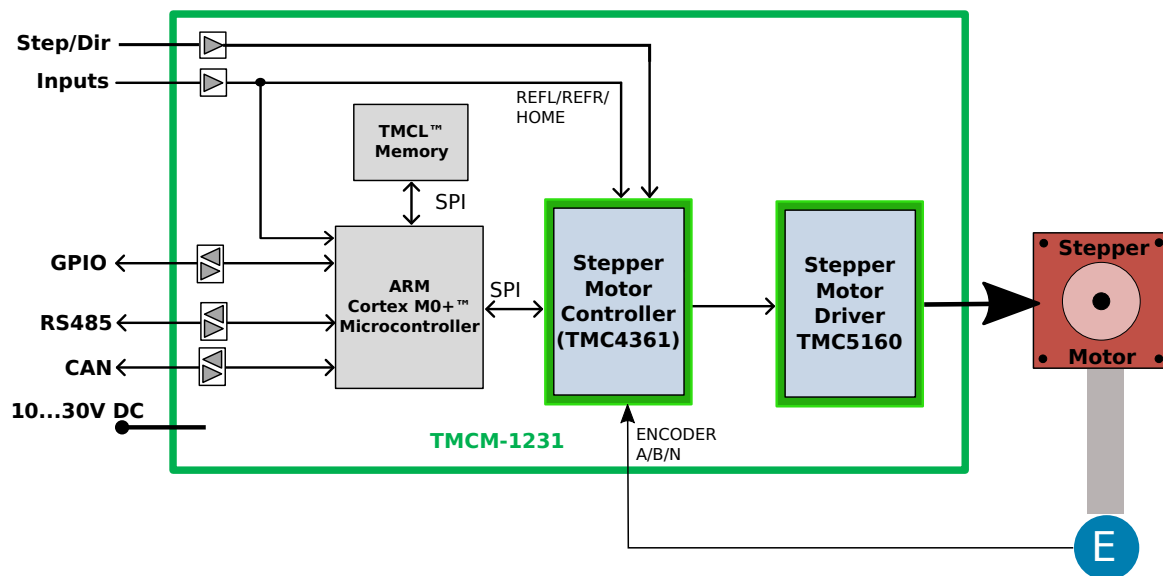

Figure 7: TMCM-1231 block diagram



9 Operational Ratings and Characteristics

NOTICE

Never Exceed the absolute maximum ratings! Keep the power supply voltage below the upper limit of +30V! Otherwise the board electronics will seriously be damaged! Especially, when the selected operating voltage is near the upper limit a regulated power supply is highly recommended.

General Operational Ratings					
Symbol	Parameter	Min	Typ	Max	Unit
V_{Motor}	Motor power supply voltage	10	24...48	52	V
I_{Motor}	Motor power supply current		$\ll I_{\text{COIL_RMS}}$	$1.4 \times I_{\text{COIL_RMS}}$	A
V_{Logic}	Logic power supply voltage		5		V
I_{Logic}	Logic power supply current		tbd		mA
$I_{\text{COIL_PEAK}}$	Motor coil current for sine wave peak (chopper regulated, adjustable via software)	0	0...9.2	9.2	A
$I_{\text{COIL_RMS}}$	Continuous motor current (RMS)	0	0...6.5	6.5	A
T_{ENV}	Environmental temperature at rated current (no forced cooling required)	-30		60	°C

Table 4: General operational ratings of the module

Operational Ratings of the I/Os					
Symbol	Parameter	Min	Typ	Max	Unit
V_{OUT}	Voltage at digital outputs OUT0 and OUT1	0		5	V
I_{OUT}	Current through OUT0 and OUT1			20	mA
$V_{\text{IN0/1/2/3}}$	Input voltage for inputs IN0...IN3	0	0...5	5	V
$V_{\text{IN0/1}}$	Measurement range for analog inputs IN0, IN1	0		5	V
$V_{\text{IN1/2_L}}$	Low level voltage for IN0...IN3 (digital inputs)			1	V
$V_{\text{IN1/2_H}}$	High level voltage for IN0...IN3 (digital inputs)	2.9			V
$V_{\text{STOP_L/R_L}}$	Low level voltage for stop and home switch inputs		1		V
$V_{\text{STOP_L/R_H}}$	High level voltage for stop and home switch inputs	0	2.9		V
$f_{\text{STEP/DIR}}$	Max. frequency for step/direction inputs		250		kHz

Table 5: Operational ratings of I/Os



Operational Ratings of the RS485 Interface					
Symbol	Parameter	Min	Typ	Max	Unit
N_{RS485}	Number of nodes connected to single RS485 network			256	
f_{RS485}	Max. speed for RS485 network			1Mbit/s	

Table 6: Operational ratings of the RS485 interface

Operational Ratings of the CAN Interface					
Symbol	Parameter	Min	Typ	Max	Unit
N_{CAN}	Number of nodes connected to single CAN network			>110	
f_{CAN}	Max. speed for CAN network			1Mbit/s	

Table 7: Operational ratings of the CAN interface



10 Abbreviations used in this Manual

Abbreviation	Description
IDE	Integrated Development Environment
LED	Light Emmitting Diode
RMS	Root Mean Square value
TMCL	TRINAMIC Motion Control Language

Table 8: Abbreviations used in this Manual



11 Figures Index

1	Board dimensions, position of mounting holes and position (pin 1) of connectors (all values in mm)	6	4	RS485 bus lines with resistor (bias) network on one side, only	15
2	Reset to factory default settings	11	5	RS485 bus lines with Profibus™recommended line termination	15
3	RS485 bus structure with termination resistors	14	6	CAN bus structure with termination resistors	16
			7	TMCM-1231 block diagram	17



12 Tables Index

1	TMCM-1231 Order Codes	5	6	Operational ratings of the RS485 inter- face	19
2	Top Side Slot Connector Pin Assignment	8	7	Operational ratings of the CAN interface	19
3	Bottom Side Slot Connector Pin As- signment	10	8	Abbreviations used in this Manual . .	20
4	General operational ratings of the module	18	9	Hardware Revision	25
5	Operational ratings of I/Os	18	10	Document Revision	25



13 Supplemental Directives

13.1 Producer Information

13.2 Copyright

TRINAMIC owns the content of this user manual in its entirety, including but not limited to pictures, logos, trademarks, and resources. © Copyright 2020 TRINAMIC. All rights reserved. Electronically published by TRINAMIC, Germany.

Redistributions of source or derived format (for example, Portable Document Format or Hypertext Markup Language) must retain the above copyright notice, and the complete Datasheet User Manual documentation of this product including associated Application Notes; and a reference to other available product-related documentation.

13.3 Trademark Designations and Symbols

Trademark designations and symbols used in this documentation indicate that a product or feature is owned and registered as trademark and/or patent either by TRINAMIC or by other manufacturers, whose products are used or referred to in combination with TRINAMIC's products and TRINAMIC's product documentation.

This Hardware Manual is a non-commercial publication that seeks to provide concise scientific and technical user information to the target user. Thus, trademark designations and symbols are only entered in the Short Spec of this document that introduces the product at a quick glance. The trademark designation /symbol is also entered when the product or feature name occurs for the first time in the document. All trademarks and brand names used are property of their respective owners.

13.4 Target User

The documentation provided here, is for programmers and engineers only, who are equipped with the necessary skills and have been trained to work with this type of product.

The Target User knows how to responsibly make use of this product without causing harm to himself or others, and without causing damage to systems or devices, in which the user incorporates the product.

13.5 Disclaimer: Life Support Systems

TRINAMIC Motion Control GmbH & Co. KG does not authorize or warrant any of its products for use in life support systems, without the specific written consent of TRINAMIC Motion Control GmbH & Co. KG.

Life support systems are equipment intended to support or sustain life, and whose failure to perform, when properly used in accordance with instructions provided, can be reasonably expected to result in personal injury or death.

Information given in this document is believed to be accurate and reliable. However, no responsibility is assumed for the consequences of its use nor for any infringement of patents or other rights of third parties which may result from its use. Specifications are subject to change without notice.

13.6 Disclaimer: Intended Use

The data specified in this user manual is intended solely for the purpose of product description. No representations or warranties, either express or implied, of merchantability, fitness for a particular purpose



or of any other nature are made hereunder with respect to information/specification or the products to which information refers and no guarantee with respect to compliance to the intended use is given.

In particular, this also applies to the stated possible applications or areas of applications of the product. TRINAMIC products are not designed for and must not be used in connection with any applications where the failure of such products would reasonably be expected to result in significant personal injury or death (safety-Critical Applications) without TRINAMIC's specific written consent.

TRINAMIC products are not designed nor intended for use in military or aerospace applications or environments or in automotive applications unless specifically designated for such use by TRINAMIC. TRINAMIC conveys no patent, copyright, mask work right or other trade mark right to this product. TRINAMIC assumes no liability for any patent and/or other trade mark rights of a third party resulting from processing or handling of the product and/or any other use of the product.

13.7 Collateral Documents & Tools

This product documentation is related and/or associated with additional tool kits, firmware and other items, as provided on the product page at: www.trinamic.com.



14 Revision History

14.1 Hardware Revision

Version	Date	Author	Description
V1.0	2020-MAY-05	HH	Initial version.
V1.1	2020-AUG-13	HH	IN1 and OUT1 removed. (A41 and B41 not connected any more.)

Table 9: Hardware Revision

14.2 Document Revision

Version	Date	Author	Description
1.00	2020-MAY-25	OK	Initial version.
1.01	2020-NOV-03	OK	Covers hardware V1.1.

Table 10: Document Revision

