

Half Bridge IGBT Module **multicomp**PRO

**RoHS
Compliant**

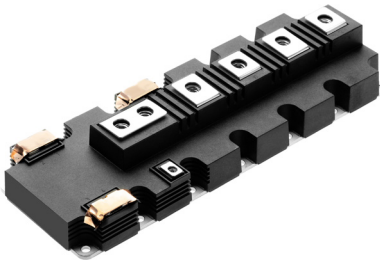

Features

- Trench Gate IGBT
- Copper Base with Aluminum Oxide Substrate
- High Thermal Cycling Capability
- 10µs Short Circuit Withstand
- Low Vce(sat) Variant

Key Parameters

V _{CES}	: 1200 V
V _{CE(sat)} * (typ)	: 1.8
I _C (max)	: 1400 A
I _{C(PK)} (max)	: 2800 A

* Measured at the auxiliary terminals

Applications

- Motor Drives
- High Power Converters
- Renewable Energy Power Conversion
- High Reliability Inverters

The MP005813 is a Half Bridge 1200V, trench gate, insulated gate bipolar transistor (IGBT) module with enhanced field stop and implantation technology. The IGBT has a wide reverse bias safe operating area (RBSOA) plus 10µs short circuit withstand. This device is optimised for traction drives and other applications requiring high thermal cycling capability.

The module incorporates an electrically isolated base plate and low inductance construction enabling circuit designers to optimise circuit layouts and utilise grounded heat sinks for safety.

Absolute Maximum Ratings

Stresses above those listed under 'Absolute Maximum Ratings' may cause permanent damage to the device. In extreme conditions, as with all semiconductors, this may include potentially hazardous rupture of the package. Appropriate safety precautions should always be followed. Exposure to Absolute Maximum Ratings may affect device reliability.

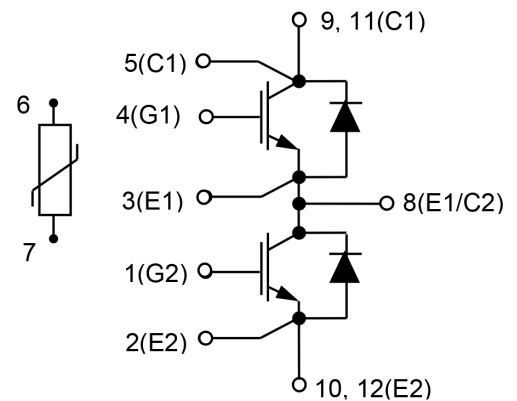

Circuit configuration

T_{case} = 25°C unless stated otherwise.

Symbol	Parameter	Test Conditions	Max.	Units
V _{CES}	Collector-emitter voltage	V _{GE} = 0V, TC = 25°C	1200	V
V _{GES}	Gate-emitter voltage	TC = 25°C	±20	
I _C	Continuous collector current	TC = 100°C	1400	A
I _{C(PK)}	Peak collector current	t _P = 1ms,	2800	
P _{max}	Max. transistor power dissipation	TC = 25°C, T _{vj} = 175°C	7.5	kW
I ² t	Diode I ² t value	V _R = 0, t _p = 10ms, T _{vj} = 150°C	172	kA ² s
V _{isol}	Isolation voltage – per module	Commoned terminals to base plate. AC RMS, 1 min, 50Hz	4000	V

Newark.com/multicomp-pro
Farnell.com/multicomp-pro
Element14.com/multicomp-pro

multicompPRO

Half Bridge IGBT Module **multicomp**PRO

Thermal And Mechanical Ratings

Internal insulation material:	Al ₂ O ₃
Baseplate material:	Cu
Creepage distance:	33mm
Clearance:	19mm
CTI (Comparative Tracking Index):	>400

Symbol	Parameter	Test Conditions	Min.	Max.	Units
R _{th(j-c)}	Thermal resistance – transistor	Continuous dissipation - junction to case	-	20	°C/kW
R _{th(j-c)}	Thermal resistance – diode			35.5	
R _{th(c-h)} IGBT	Thermal resistance – case to heatsink (IGBT)	Mounting torque 5Nm (with mounting grease: 1W/mK)	-	9.5	
R _{th(c-h)} Diode	Thermal resistance – case to heatsink (Diode)			17	
T _j	Junction temperature – under switching conditions	Transistor	-40	150	°C
		Diode			
F _{stg}	Storage temperature range	-			
	Screw torque	Mounting – M5	3	6	Nm
		Electrical connections – M8	8	10	

T_{case} = 25°C unless stated otherwise.

Symbol	Parameter	Test Conditions	Min.	Typ	Max.	Units
I _{CES}	Collector cut-off current	V _{GE} = 0V, V _{CE} = V _{CES}			1	mA
		V _{GE} = 0V, V _{CE} = V _{CES} , T _C = 125°C			20	
		V _{GE} = 0V, V _{CE} = V _{CES} , T _C = 150°C			30	
I _{GES}	Gate leakage current	V _{GE} = ± 20V, V _{CE} = 0V			0.5	µA
V _{GE(TH)}	Gate threshold voltage	I _C = 30mA, V _{GE} = V _{CE}	5	6	6.4	V
V _{CE(sat)}	Collector-emitter saturation voltage	V _{GE} = 15V, I _C = 1400A		1.8	2.25	
		V _{GE} = 15V, I _C = 1400A, T _j = 125°C		2.15	2.6	
		V _{GE} = 15V, I _C = 1400A, T _j = 150°C		2.25	2.7	
V _F	Diode forward current	DC		1400		A
V _{IFM}	Diode maximum forward current	t _p = 1ms		2800		
V _F	Diode forward voltage	I _F = 1400A		1.9	2.2	V
		I _F = 1400A, T _j = 125°C		2.1	2.3	
		I _F = 1400A, T _j = 150°C				
C _{ies}	Input capacitance	V _{CE} = 25V, V _{GE} = 0V, f = 100kHz		118		nF
Q _g	Gate charge	±15V		13		µC
Q _{res}	Reverse transfer capacitance	V _{CE} = 25V, V _{GE} = 0V, f = 100kHz		3.2		nF
L _M	Module inductance			10		nH
R _{INT}	Internal transistor resistance			0.2		mΩ
SC _{Data}	Short circuit current, I _{sc}	T _j = 150°C, V _{CC} = 800V t _p ≤ 10µs, V _{GE} ≤ 15V V _{CE(max)} = V _{CES} – L* x di/dt IEC 60747-9		5800		A

Newark.com/multicomp-pro
Farnell.com/multicomp-pro
Element14.com/multicomp-pro

multicompPRO

Half Bridge IGBT Module **multicomp** PRO

Note:

* L is the circuit inductance + L_M

NTC-Thermistor Data

Symbol	Parameter	Test Conditions	Min.	Typ	Max.	Units
R ₂₅	Rated Resistance	T _C = 25°C		5		kΩ
ΔR/R	Deviation of R ₁₀₀	T _C = 100°C, R ₁₀₀ = 493Ω	-5		5	%
P ₂₅	Power Dissipation	T _C = 25°C			20	m/W
B _{25/50}	B-value	R ₂ = R ₂₅ exp [B _{25/50} (1/T ₂ – 1/(298.15K))]		3375		K
B _{25/80}		R ₂ = R ₂₅ exp [B _{25/80} (1/T ₂ – 1/(298.15K))]		3411		
B _{25/100}		R ₂ = R ₂₅ exp [B _{25/100} (1/T ₂ – 1/(298.15K))]		3433		

Electrical Characteristics

T_{case} = 25°C unless stated otherwise.

Symbol	Parameter	Test Conditions	Min.	Typ	Max.	Units
t _{d(off)}	Turn-off delay time	I _C = 1000A V _{CE} = 900V V _{GE} = ±15V R _{G(OFF)} = 1.8Ω R _{G(ON)} = 1.2Ω L _S ~ 20nH		dv/dt = 3000V/μs		ns
t _f	Fall time					
E _{OFF}	Turn-off energy loss					
t _{d(on)}	Turn-on delay time	I _F = 1000A V _{CE} = 900V di/dt = 7200A/μs		di/dt = 7200A/μs		ns
t _r	Rise time					
E _{ON}	Turn-on energy loss					
Q _{rr}	Diode reverse recovery charge	I _F = 1000A V _{CE} = 900V di/dt = 7200A/μs				μC
I _{rr}	Diode reverse recovery current					
E _{rec}	Diode reverse recovery energy					

T_{case} = 125°C unless stated otherwise.

Symbol	Parameter	Test Conditions	Min.	Typ	Max.	Units
t _{d(off)}	Turn-off delay time	I _C = 1400A V _{CE} = 600V V _{GE} = ±15V R _{G(OFF)} = 1Ω R _{G(ON)} = 0.5Ω L _S ~ 25nH		dv/dt = 3000V/μs		ns
t _f	Fall time					
E _{OFF}	Turn-off energy loss					
t _{d(on)}	Turn-on delay time	I _F = 1400A V _{CE} = 600V di/dt = 8500A/μs		di/dt = 7200A/μs		ns
t _r	Rise time					
E _{ON}	Turn-on energy loss					
Q _{rr}	Diode reverse recovery charge	I _F = 1400A V _{CE} = 600V di/dt = 8500A/μs				μC
I _{rr}	Diode reverse recovery current					
E _{rec}	Diode reverse recovery energy					

Half Bridge IGBT Module **multicomp**PRO

T_{case} = 125°C unless stated otherwise.

Symbol	Parameter	Test Conditions	Min.	Typ	Max.	Units	
t _{d(off)}	Turn-off delay time	I _C = 1400A V _{CE} = 600V V _{GE} = ±15V R _{G(OFF)} = 1Ω R _{G(ON)} = 0.5Ω L _s ~ 25nH		1200		ns	
t _f	Fall time			dv/dt = 2100V/μs	340		
E _{OFF}	Turn-off energy loss				285		
t _{d(on)}	Turn-on delay time		di/dt = 8500A/μs		290		ns
t _r	Rise time			195			
E _{ON}	Turn-on energy loss			208		mJ	
Q _{rr}	Diode reverse recovery charge	I _F = 1400A V _{CE} = 600V di/dt = 8500A/μs		236		μC	
I _{rr}	Diode reverse recovery current			765		A	
E _{rec}	Diode reverse recovery energy			102		mJ	

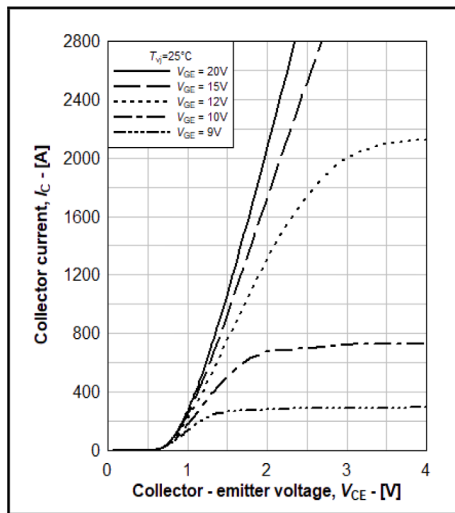

Fig. 3 Typical IGBT output characteristics, $I_c = f(V_{ce})$

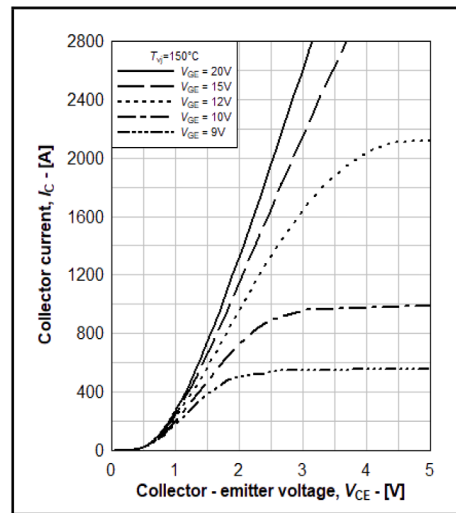

Fig. 4 Typical IGBT output characteristics, $I_c = f(V_{ce})$

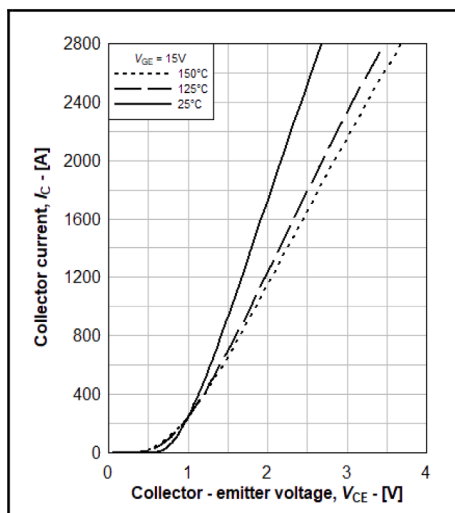

Fig. 5 Typical IGBT output characteristics, $I_c = f(V_{ce})$

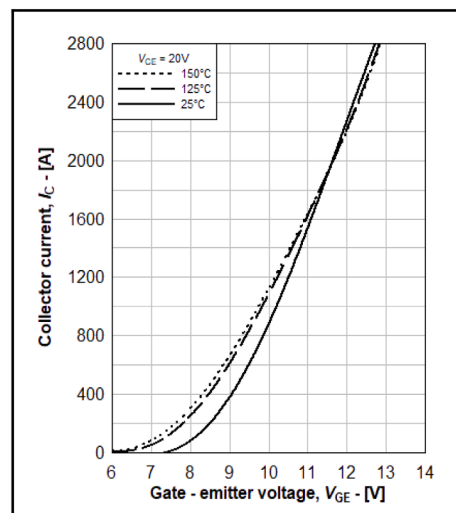

Fig. 6 Typical IGBT transfer characteristics, $I_c = f(V_{ge})$

Half Bridge IGBT Module **multicomp**PRO

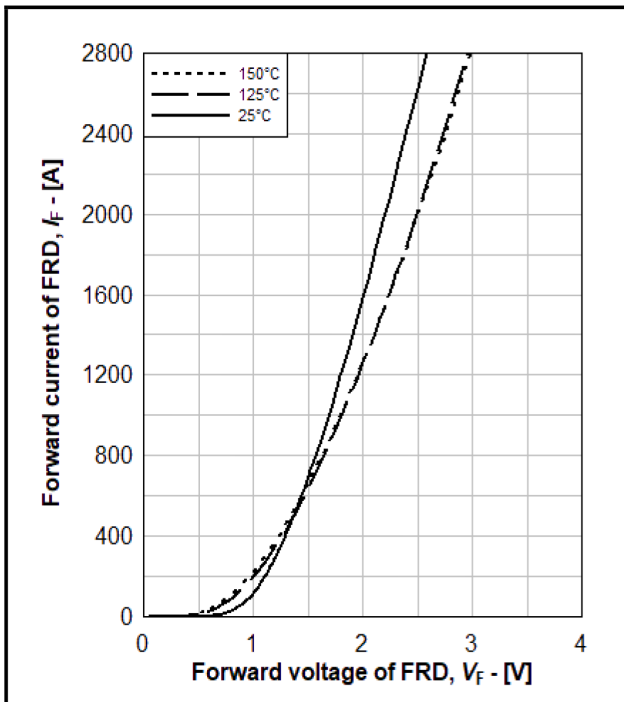

Fig. 7 Diode typical forward characteristics, $I_F = f(V_F)$

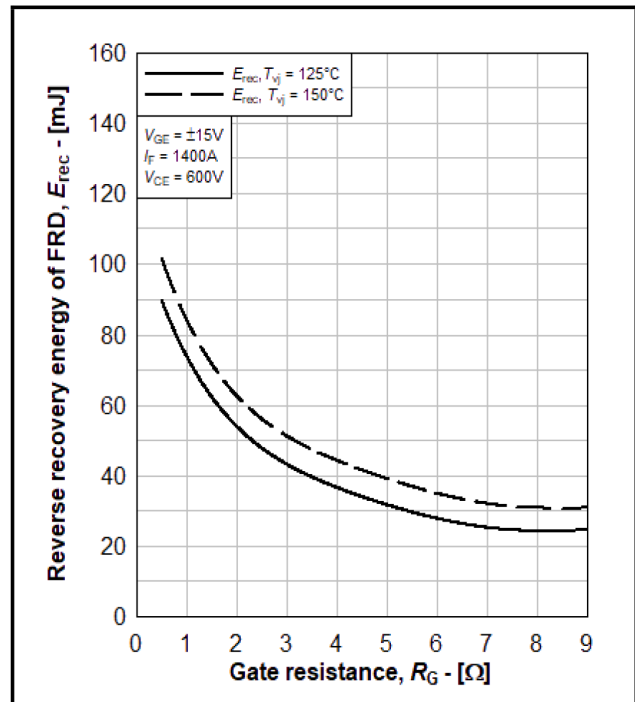

Fig. 8 Typical FRD E_{rec} , $E_{rec} = f(R_G)$

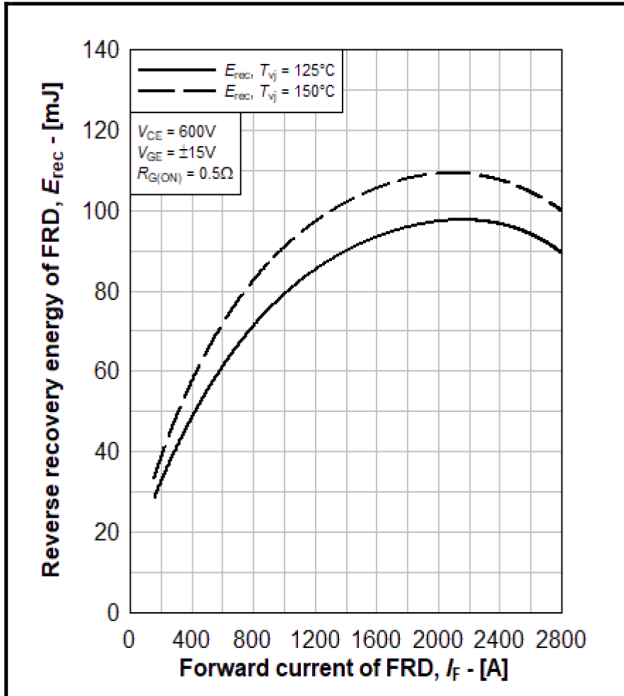

Fig. 9 Typical FRD E_{rec} , $E_{rec} = f(I_F)$

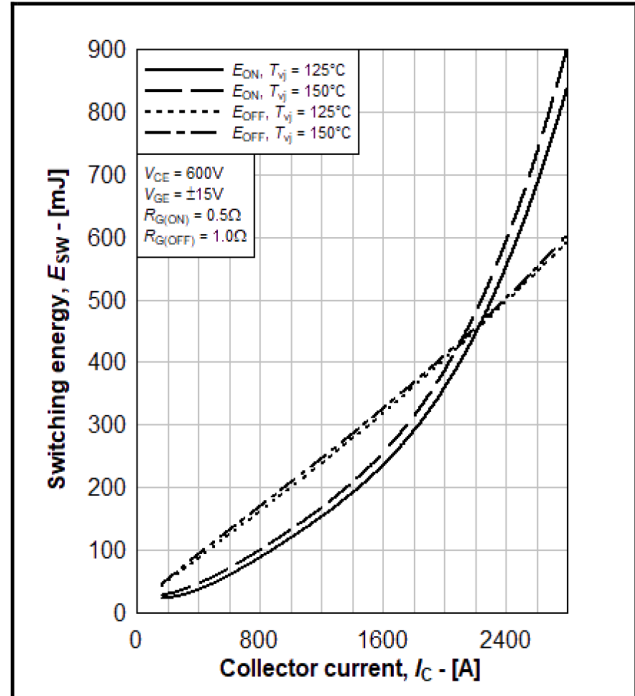

Fig. 10 Typical IGBT switching energy, $E_{ON} = f(I_C)$, $E_{OFF} = f(I_C)$

Half Bridge IGBT Module **multicomp**PRO

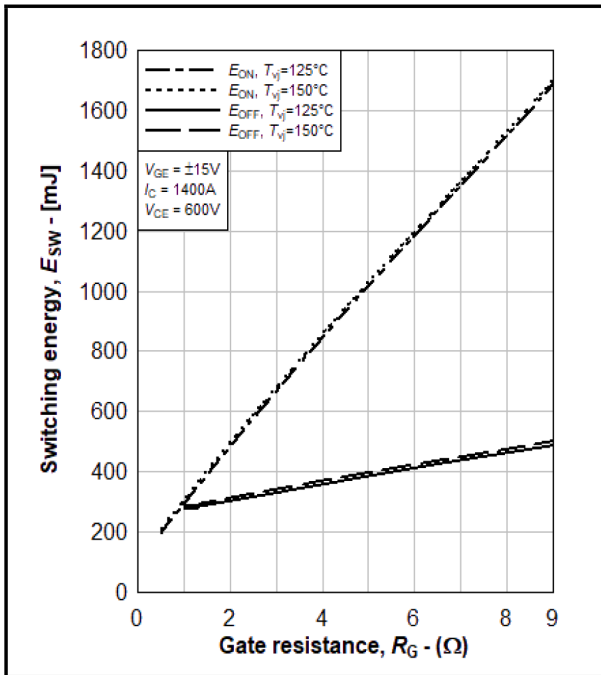

Fig. 11 Typical IGBT switching energy
 $E_{ON} = f(R_G)$, $E_{OFF} = f(R_G)$

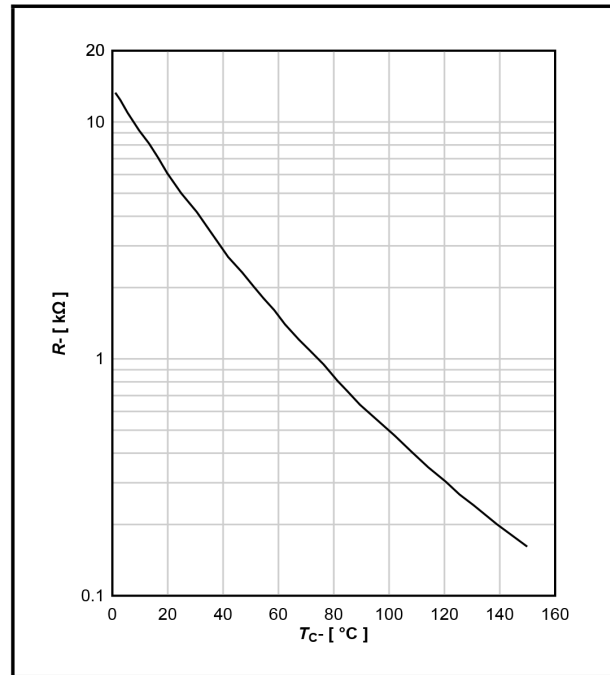

Fig. 12 Typical NTC thermistor characteristic, $R = f(T_c)$

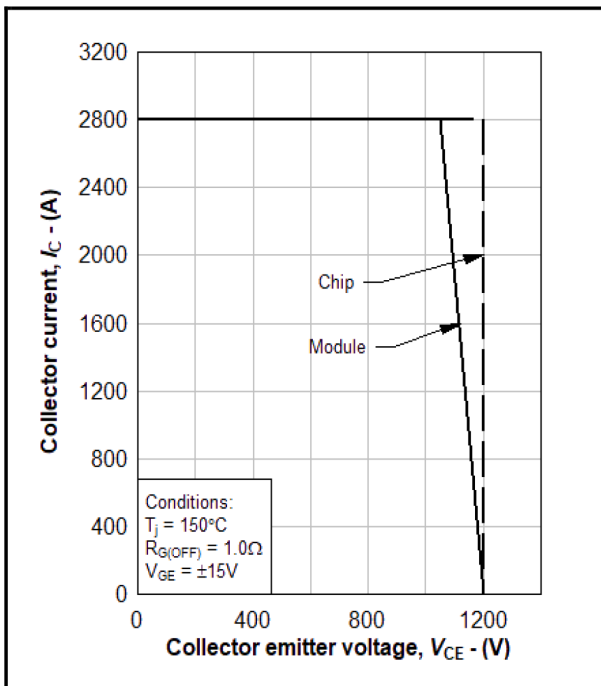

Fig. 13 Reverse bias safe operating area of IGBT,
 $I_C = f(V_{CE})$

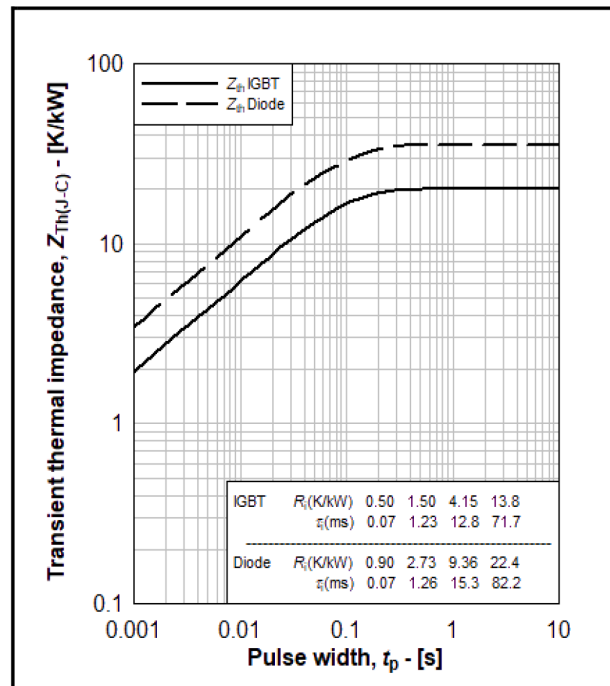
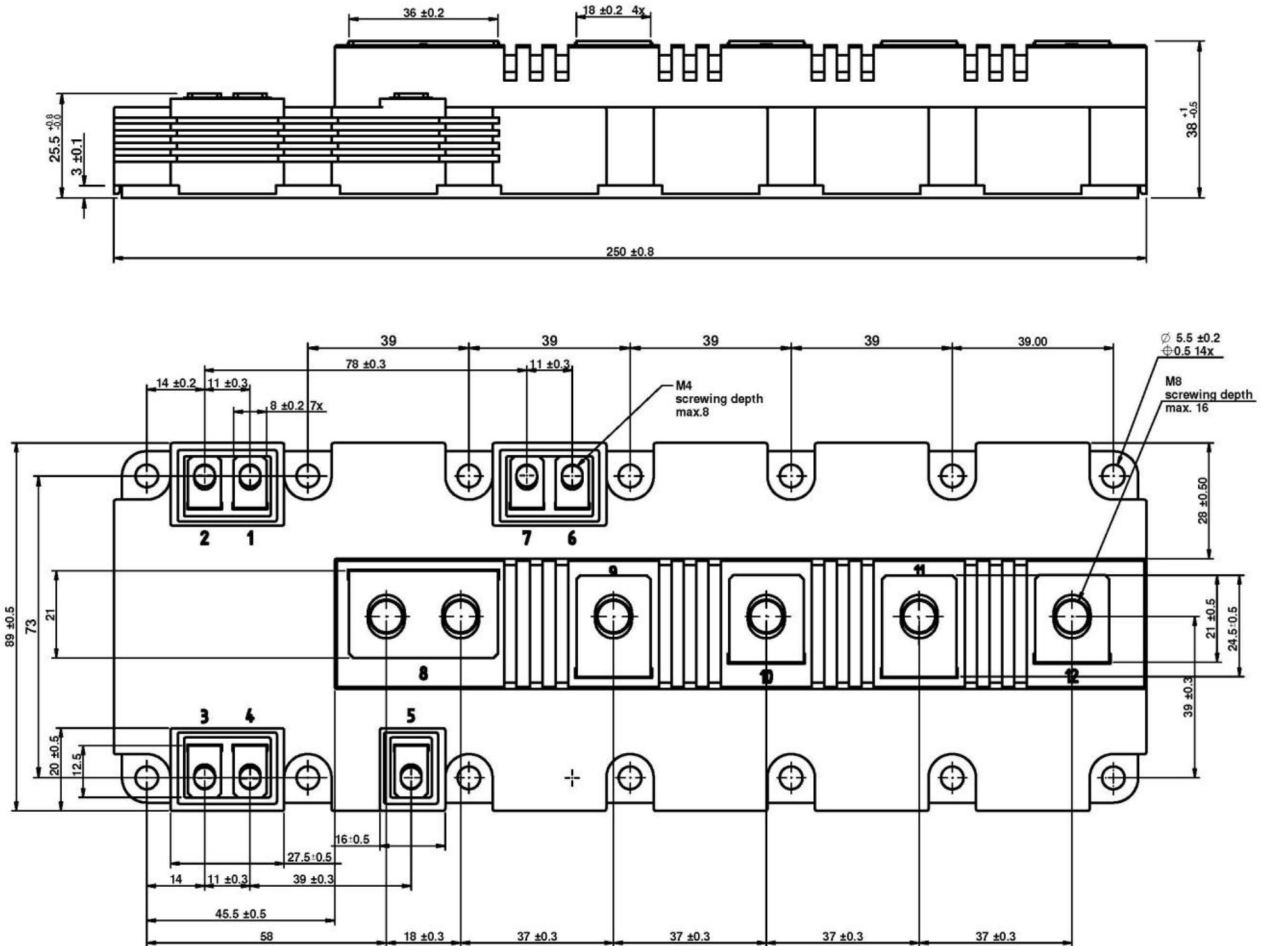

Fig. 14 Transient thermal impedance, $Z_{th(J-c)} = f(t)$

Half Bridge IGBT Module **multicomp**PRO



Nominal Weight: 1200g

Part Number Table

Description	Part Number
Half Bridge IGBT Module, 1200V, 1400A, H1 Case Code	MPIM1400H112TG5

Important Notice : This data sheet and its contents (the "Information") belong to the members of the AVNET group of companies (the "Group") or are licensed to it. No licence is granted for the use of it other than for information purposes in connection with the products to which it relates. No licence of any intellectual property rights is granted. The Information is subject to change without notice and replaces all data sheets previously supplied. The Information supplied is believed to be accurate but the Group assumes no responsibility for its accuracy or completeness, any error in or omission from it or for any use made of it. Users of this data sheet should check for themselves the Information and the suitability of the products for their purpose and not make any assumptions based on information included or omitted. Liability for loss or damage resulting from any reliance on the Information or use of it (including liability resulting from negligence or where the Group was aware of the possibility of such loss or damage arising) is excluded. This will not operate to limit or restrict the Group's liability for death or personal injury resulting from its negligence. Multicomp Pro is the registered trademark of Premier Farnell Limited 2019.

Newark.com/multicomp-pro
 Farnell.com/multicomp-pro
 Element14.com/multicomp-pro

multicompPRO