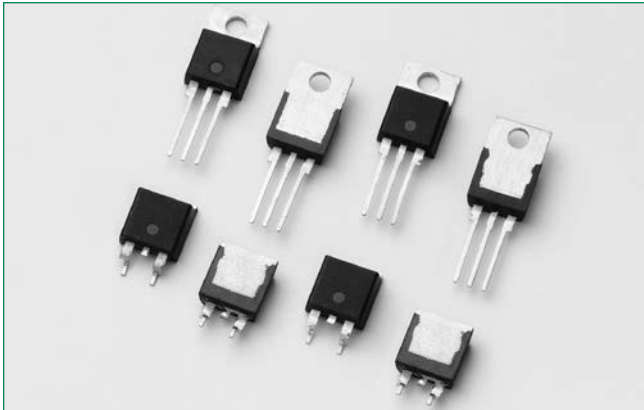


SVxx16xx series



**Description**

The SVxx16xx high junction temperature SCR series is ideal for uni-directional switch applications such as phase control in heating, motor speed controls, converters/rectifiers and inrush current controllers.

These SCRs have a low gate current, (IGT) trigger level of 6mA and 10mA maximum at approximately 1.5V for SVxx16x1 and SVxx16x2, respectively.

**Features & Benefits**

- Halogen free and RoHS compliant
- Surge capability up to 225A at 60 Hz half cycle
- 150°C maximum junction temperature
- High dv/dt performance

**Main Features**

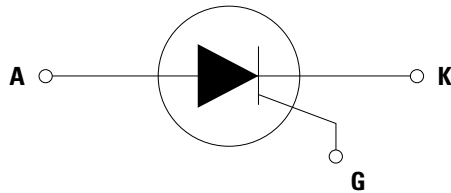
Symbol	Value	Unit
$I_{T(RMS)}$	16	A
$V_{DRM}/V_{RRM}$	600	V
$I_{GT}$	6 to 10	mA

**Applications**

Typical applications include AC Generator (ACG) rectifiers, battery voltage regulators, generic converters and inrush current controller in various AC and DC applications. Additional applications include controls for power tools, home/brown good and white goods appliances.

Internally constructed isolated packages are offered for ease of heat sinking with high isolation voltage.

**Schematic Symbol**



### Absolute Maximum Ratings — Standard SCRs

Symbol	Parameter	Test Conditions	Value	Unit
$V_{DSM} / N_{RSM}$	Peak non-repetitive blocking voltage	PW=100 $\mu$ s	800	V
$I_{T(RMS)}$	RMS on-state current	SVxx16Lx $T_c = 110^\circ\text{C}$	16	A
		SVxx16Rx SVxx16Nx $T_c = 135^\circ\text{C}$	16	
$I_{T(AV)}$	Average on-state current	SVxx16Lx $T_c = 110^\circ\text{C}$	10.2	A
		SVxx16Rx SVxx16Nx $T_c = 135^\circ\text{C}$	10.2	
$I_{TSM}$	Peak non-repetitive surge current	single half cycle; f = 50Hz; $T_j(\text{initial}) = 25^\circ\text{C}$	188	A
		single half cycle; f = 60Hz; $T_j(\text{initial}) = 25^\circ\text{C}$	225	
$I^2t$	$I^2t$ Value for fusing	$t_p = 8.3$ ms	210	A <sup>2</sup> s
di/dt	Critical rate of rise of on-state current	f = 60 Hz ; $T_j = 150^\circ\text{C}$	100	A/ $\mu$ s
$I_{GM}$	Peak gate current	$T_j = 150^\circ\text{C}$	4	A
$P_{G(AV)}$	Average gate power dissipation	$T_j = 150^\circ\text{C}$	0.8	W
$T_{stg}$	Storage temperature range		-40 to 150	$^\circ\text{C}$
$T_j$	Operating junction temperature range		-40 to 150	$^\circ\text{C}$

Note: xx=voltage/10, x=sensitivity

### Electrical Characteristics ( $T_j = 25^\circ\text{C}$ , unless otherwise specified)

Symbol	Test Conditions		SVxx16x1	SVxx16x2	Unit
$I_{GT}$	$V_D = 12\text{V}; R_L = 60 \Omega$	MIN.	2	5	mA
		MAX.	6	10	
$V_{GT}$		MAX.	1.5	1.5	V
dv/dt	$V_D = 67\%V_{DRM}$ ; gate open; $T_j = 125^\circ\text{C}$	MIN.	400	800	V/ $\mu$ s
	$V_D = 67\%V_{DRM}$ ; gate open; $T_j = 150^\circ\text{C}$		200	400	
$V_{GD}$	$V_D = V_{DRM}; R_L = 3.3 \text{ k}\Omega; T_j = 150^\circ\text{C}$	MIN.	0.2	0.2	V
$I_H$	$I_T = 200\text{mA}$ (initial)	MAX.	22	35	mA
$t_q$	$I_T = 2\text{A}; t_p = 50\mu\text{s}; dv/dt = 5\text{V}/\mu\text{s}; di/dt = 30\text{A}/\mu\text{s}$	MAX.	25	25	$\mu$ s
$t_{gt}$	$I_G = 2 \times I_{GT}; P_W = 15\mu\text{s}; I_T = 32\text{A}$	TYP.	2.6	2.6	$\mu$ s

Note: xx=voltage/10, x=package

### Static Characteristics

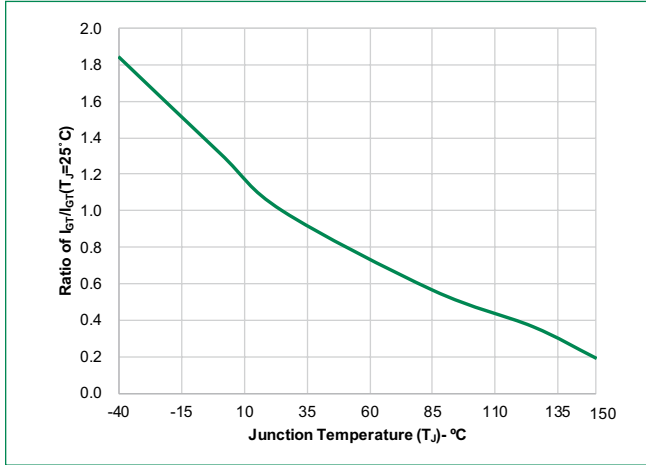
Symbol	Test Conditions	Value	Unit
$V_{TM}$	$I_T = 32\text{A}; t_p = 380 \mu\text{s}$	MAX.	1.6
$I_{DRM} / I_{RRM}$	$V_{DRM} = V_{RRM}$	$T_j = 25^\circ\text{C}$	10
		$T_j = 125^\circ\text{C}$	1000
		$T_j = 150^\circ\text{C}$	3000

### Thermal Resistances

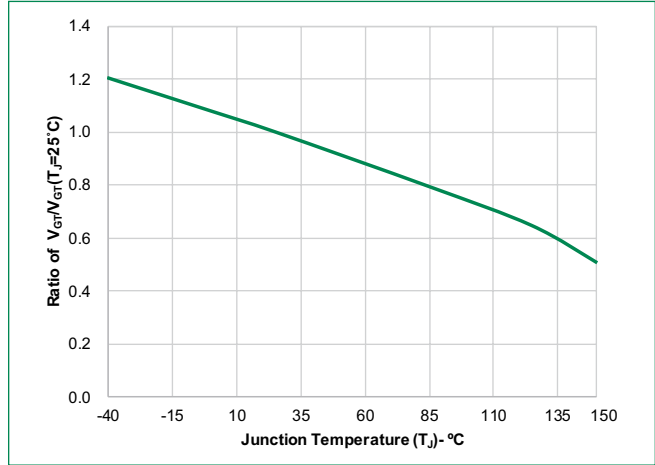
Symbol	Parameter	Value	Unit
$R_{\theta(JC)}$	Junction to case (AC)	SVxx16Rx SVxx16Nx	1.0
		SVxx16Lx	2.5

Note: xx=voltage/10, x=sensitivity

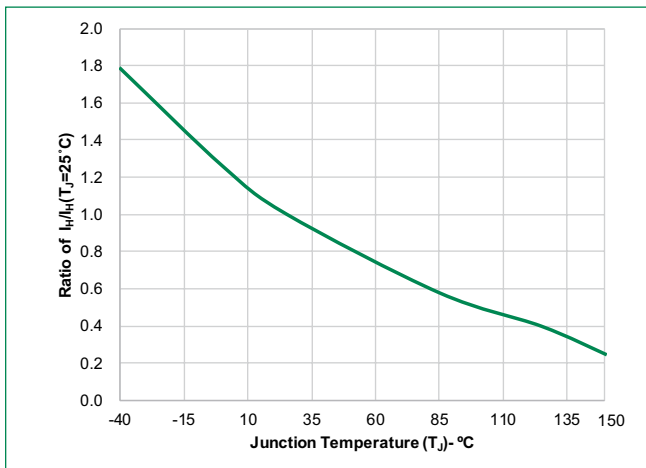
**Figure 1: Normalized DC Gate Trigger Current vs. Junction Temperature**



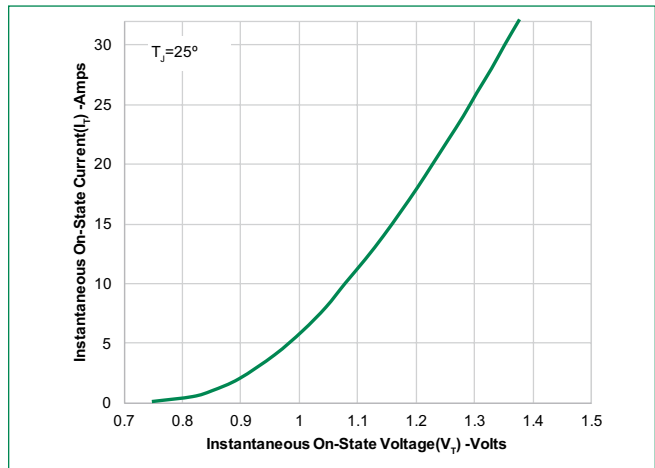
**Figure 2: Normalized DC Gate Trigger Voltage vs. Junction Temperature**



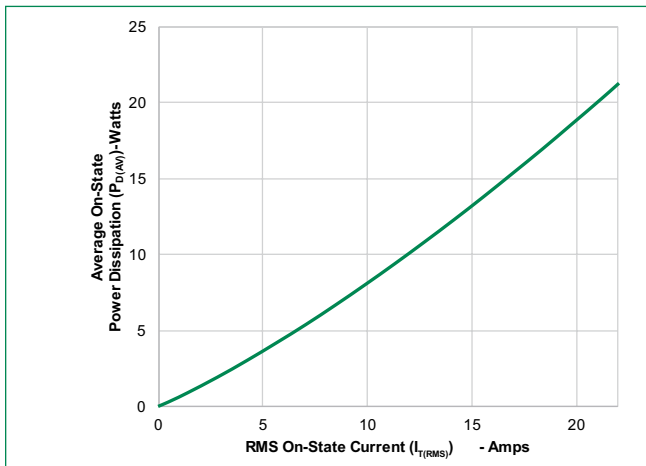
**Figure 3: Normalized DC Holding Current vs. Junction Temperature**



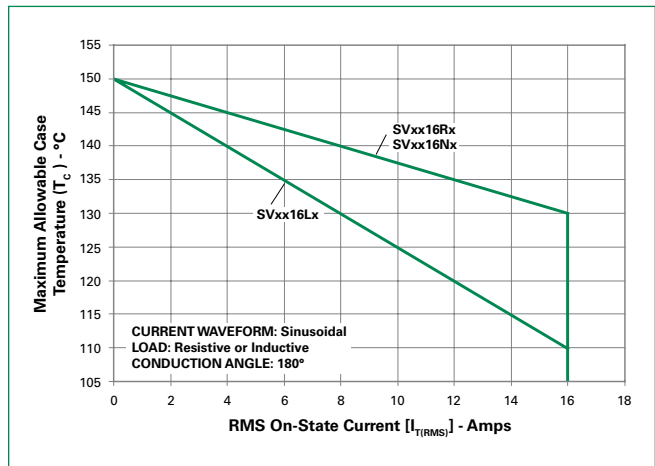
**Figure 4: On-State Current vs. On-State Voltage (Typical)**



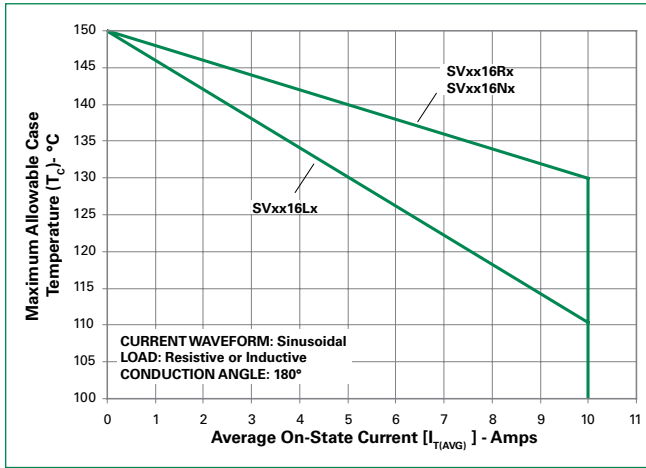
**Figure 5: Power Dissipation (Typical) vs. RMS On-State Current**



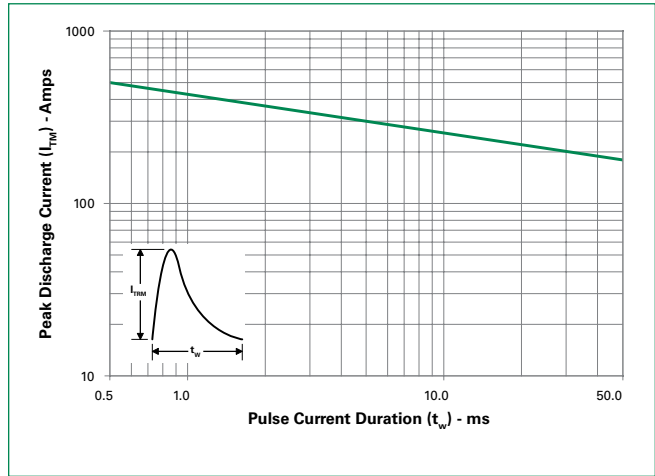
**Figure 6: Maximum Allowable Case Temperature vs. RMS On-State Current**



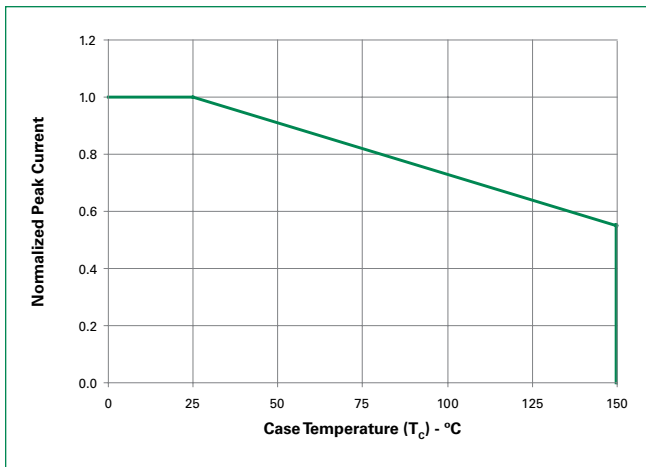
**Figure 7: Maximum Allowable Case Temperature vs. Average On-State Current**



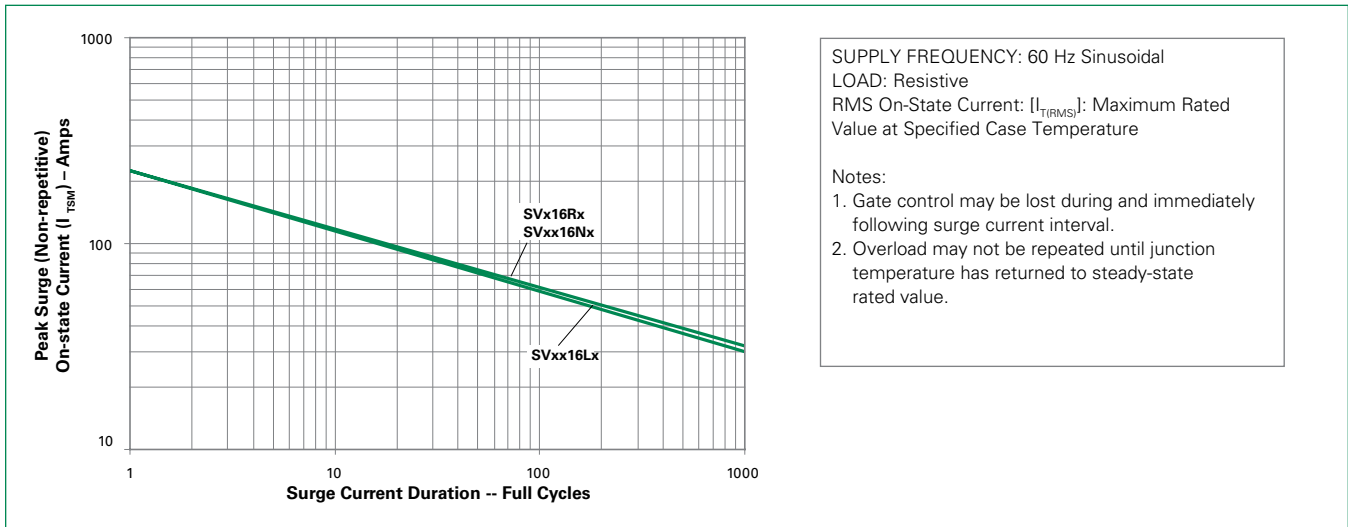
**Figure 8: Peak Capacitor Discharge Current**



**Figure 9: Peak Capacitor Discharge Current Derating**

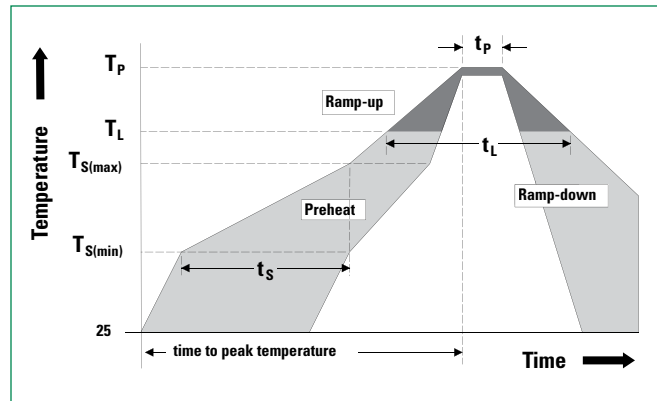


**Figure 10: Surge Peak On-State Current vs. Number of Cycles**



### Soldering Parameters

<b>Reflow Condition</b>		Pb – Free assembly
<b>Pre Heat</b>	- Temperature Min ( $T_{s(min)}$ )	150°C
	- Temperature Max ( $T_{s(max)}$ )	200°C
	- Time (min to max) ( $t_s$ )	60 – 180 secs
<b>Average ramp up rate (Liquidus Temp) (<math>T_L</math>) to peak</b>		5°C/second max
<b><math>T_{s(max)}</math> to <math>T_L</math> - Ramp-up Rate</b>		5°C/second max
<b>Reflow</b>	- Temperature ( $T_L$ ) (Liquidus)	217°C
	- Time ( $t_L$ )	60 – 150 seconds
<b>Peak Temperature (<math>T_p</math>)</b>		260 <sup>+0/-5</sup> °C
<b>Time within 5°C of actual peak Temperature (<math>t_p</math>)</b>		20 – 40 seconds
<b>Ramp-down Rate</b>		5°C/second max
<b>Time 25°C to peak Temperature (<math>T_p</math>)</b>		8 minutes Max.
<b>Do not exceed</b>		280°C



### Physical Specifications

<b>Terminal Finish</b>	100% Matte Tin-plated
<b>Body Material</b>	UL Recognized compound meeting flammability rating V-0
<b>Lead Material</b>	Copper Alloy

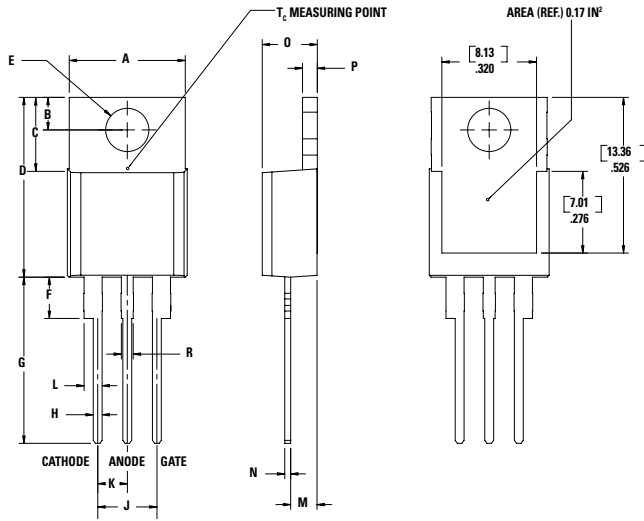
### Design Considerations

Careful selection of the correct component for the application's operating parameters and environment will go a long way toward extending the operating life of the Thyristor. Good design practice should limit the maximum continuous current through the main terminals to 75% of the component rating. Other ways to ensure long life for a power discrete semiconductor are proper heat sinking and selection of voltage ratings for worst case conditions. Overheating, overvoltage (including dv/dt), and surge currents are the main killers of semiconductors. Correct mounting, soldering, and forming of the leads also help protect against component damage.

### Environmental Specifications

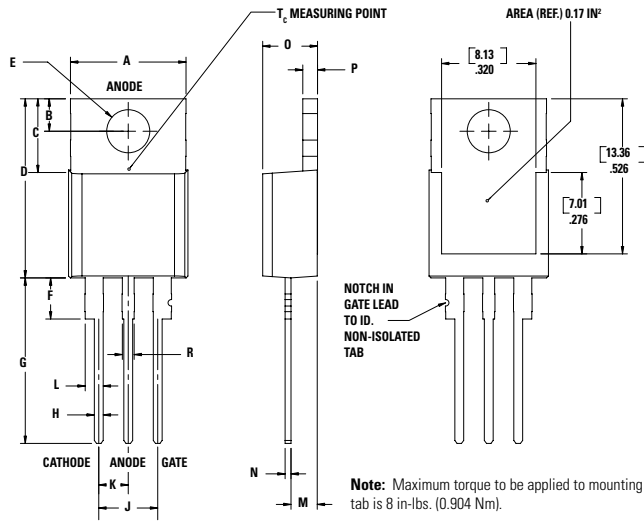
Test	Specifications and Conditions
<b>AC Blocking</b>	MIL-STD-750, M-1040, Cond A Applied Peak AC voltage @ 150°C for 1008 hours
<b>Temperature Cycling</b>	MIL-STD-750, M-1051, 1000 cycles; -55°C to +150°C; 15-min dwell-time
<b>Temperature/Humidity</b>	EIA / JEDEC, JESD22-A101 1008 hours; 160V - DC; 85°C; 85% rel humidity
<b>Resistance to Solder Heat</b>	MIL-STD-750 Method 2031
<b>Solderability</b>	ANSI/J-STD-002, category 3, Test A
<b>Lead Bend</b>	MIL-STD-750, M-2036 Cond E
<b>Moisture Sensitivity Level</b>	Level 1, JEDEC-J-STD-020D

### Dimensions — TO-220AB (L-Package) — Isolated Mounting Tab



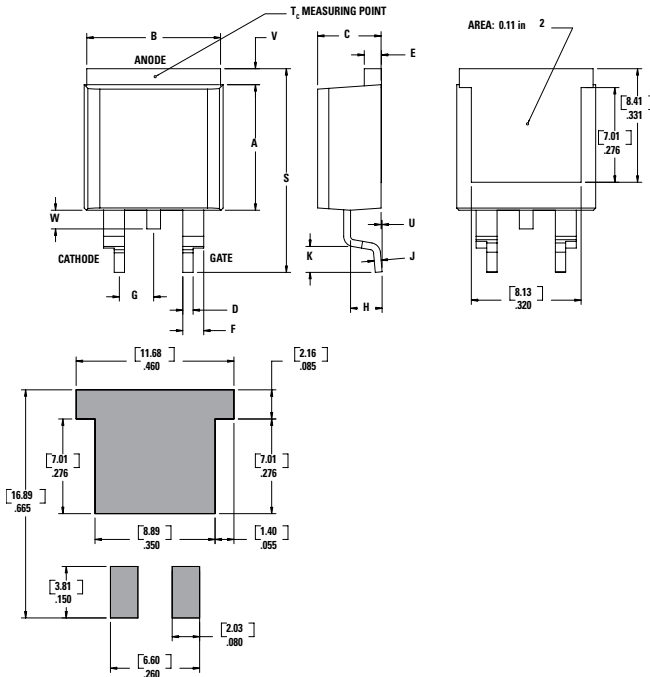
Dimension	Inches		Millimeters	
	Min	Max	Min	Max
A	0.380	0.420	9.65	10.67
B	0.105	0.115	2.67	2.92
C	0.230	0.250	5.84	6.35
D	0.590	0.620	14.99	15.75
E	0.142	0.147	3.61	3.73
F	0.110	0.130	2.79	3.30
G	0.540	0.575	13.72	14.61
H	0.025	0.035	0.64	0.89
J	0.195	0.205	4.95	5.21
K	0.095	0.105	2.41	2.67
L	0.060	0.075	1.52	1.91
M	0.085	0.095	2.16	2.41
N	0.018	0.024	0.46	0.61
O	0.178	0.188	4.52	4.78
P	0.045	0.060	1.14	1.52
R	0.038	0.048	0.97	1.22

### Dimensions — TO-220AB (R-Package) — Non-Isolated Mounting Tab Common with Center Lead



Dimension	Inches		Millimeters	
	Min	Max	Min	Max
A	0.380	0.420	9.65	10.67
B	0.105	0.115	2.67	2.92
C	0.230	0.250	5.84	6.35
D	0.590	0.620	14.99	15.75
E	0.142	0.147	3.61	3.73
F	0.110	0.130	2.79	3.30
G	0.540	0.575	13.72	14.61
H	0.025	0.035	0.64	0.89
J	0.195	0.205	4.95	5.21
K	0.095	0.105	2.41	2.67
L	0.060	0.075	1.52	1.91
M	0.085	0.095	2.16	2.41
N	0.018	0.024	0.46	0.61
O	0.178	0.188	4.52	4.78
P	0.045	0.060	1.14	1.52
R	0.038	0.048	0.97	1.22

### Dimensions — TO-263AB (N-package) — D<sup>2</sup>-Pak Surface Mount



Dimension	Inches		Millimeters	
	Min	Max	Min	Max
<b>A</b>	0.360	0.370	9.14	9.40
<b>B</b>	0.380	0.420	9.65	10.67
<b>C</b>	0.178	0.188	4.52	4.78
<b>D</b>	0.025	0.035	0.64	0.89
<b>E</b>	0.045	0.060	1.14	1.52
<b>F</b>	0.060	0.075	1.52	1.91
<b>G</b>	0.095	0.105	2.41	2.67
<b>H</b>	0.092	0.102	2.34	2.59
<b>J</b>	0.018	0.024	0.46	0.61
<b>K</b>	0.090	0.110	2.29	2.79
<b>S</b>	0.590	0.625	14.99	15.88
<b>V</b>	0.035	0.045	0.89	1.14
<b>U</b>	0.002	0.010	0.05	0.25
<b>W</b>	0.040	0.070	1.02	1.78

### Product Selector

Part Number	Voltage	Gate Sensitivity	Type	Package
	600V			
SVxx16L1	X	6mA	Standard SCR	TO-220L
SVxx16R1	X	6mA	Standard SCR	TO-220R
SVxx16N1	X	6mA	Standard SCR	TO-263
SVxx16L2	X	10mA	Standard SCR	TO-220L
SVxx16R2	X	10mA	Standard SCR	TO-220R
SVxx16N2	X	10mA	Standard SCR	TO-263

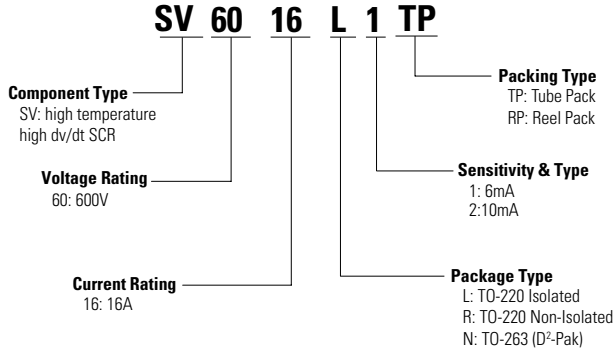
Note: xx = Voltage/10

### Packing Options

Part Number	Marking	Weight	Packing Mode	Base Quantity
SVxx16LxTP	SVxx16Ly	2.2g	Tube	1000 (50 per tube)
SVxx16RxTP	SVxx16Ry	2.2g	Tube	1000 (50 per tube)
SVxx16NxTP	SVxx16Ny	1.6g	Tube	1000 (50 per tube)
SVxx16NxRP	SVxx16Ny	1.6g	Embossed Carrier	500

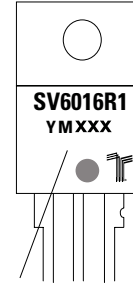
Note: xx=voltage/10, x=sensitivity

### Part Numbering System



### Part Marking System

T0-220 AB - (L and R Package)  
T0-263 AB - (N Package)



**Date Code Marking**  
Y: Year Code  
M: Month Code  
XXX: Lot Trace Code

### TO-263 Embossed Carrier Reel Pack (RP) Specifications

Meets all EIA-481-2 Standards

