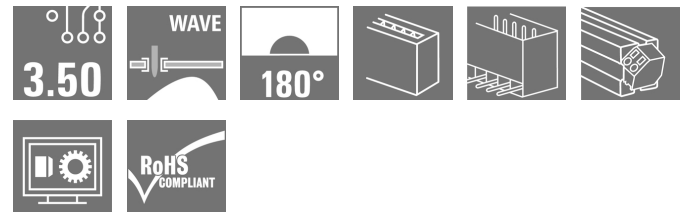

**OMNIMATE Signal - series BL/SL 3.50  
BLL 3.50/02/180 3.2SN OR TU**

**Weidmüller Interface GmbH & Co. KG**  
Klingenbergstraße 16  
D-32758 Detmold  
Germany  
Fon: +49 5231 14-0  
Fax: +49 5231 14-292083  
www.weidmueller.com

**Product image**

Similar to illustration

Inverted female header for:

- finger-safety on the PCB
- Board-to-board component connection (with SL/SL-SMT 3.50)
- Wave soldering
- Outlet direction: 180° (standing, vertical to PCB)

**General ordering data**

Type	BLL 3.50/02/180 3.2SN OR TU
Order No.	<a href="#">1376310000</a>
Version	PCB plug-in connector, female header, closed side, THT solder connection, 3.50 mm, No. of poles: 2, 180°, Solder pin length (l): 3.2 mm, tinned, orange, Tube
GTIN (EAN)	4050118177374
Qty.	75 pc(s).
Product data	IEC: 320 V / 15.1 A UL: 300 V / 9 A
Packaging	Tube

**OMNIMATE Signal - series BL/SL 3.50  
BLL 3.50/02/180 3.2SN OR TU**

**Weidmüller Interface GmbH & Co. KG**  
 Klingenbergstraße 16  
 D-32758 Detmold  
 Germany  
 Fon: +49 5231 14-0  
 Fax: +49 5231 14-292083  
 www.weidmueller.com

**Technical data****Dimensions and weights**

Height	14.3 mm	Height (inches)	0.563 inch
Depth	11.85 mm	Depth (inches)	0.467 inch
Net weight	0.74 g		

**System specifications**

Product family	OMNIMATE Signal - series BL/SL 3.50	Type of connection	Board connection
Mounting onto the PCB	THT solder connection	Pitch in mm (P)	3.5 mm
Pitch in inches (P)	0.138 inch	Outgoing elbow	180°
No. of poles	2	Number of solder pins per pole	1
Solder pin length (l)	3.2 mm	Solder pin length tolerance	+0.2 / -0.2 mm
Tolerance of solder pin position	± 0.1 mm	Solder pin dimensions	d = 0.8 mm
Solder pin dimensions = d tolerance	0 / -0,03 mm	Solder eyelet hole diameter (D)	1.3 mm
Solder eyelet hole diameter tolerance (D)+ 0,1 mm		L1 in mm	3.5 mm
L1 in inches	0.138 inch	Number of rows	1
Pin series quantity	1	Touch-safe protection acc. to DIN VDE 57 106	Safe from finger touch
Touch-safe protection acc. to DIN VDE 0470	IP 20	Can be coded	Yes
Plugging cycles	25	Plugging force/pole, max.	8 N
Pulling force/pole, max.	7 N		

**Material data**

Insulating material	PBT	Colour	orange
Colour chart (similar)	RAL 2000	Insulating material group	IIIa
CTI	≥ 200	Insulation strength	≥ 10 <sup>8</sup> Ω
UL 94 flammability rating	V-0	GWFI	960 °C
Contact material	CuSn	Contact surface	tinned
Layer structure of solder connection	4-6 µm Sn glossy	Layer structure of plug contact	4-6 µm Sn glossy
Storage temperature, min.	-25 °C	Storage temperature, max.	55 °C
Max. relative humidity during storage	80 %	Operating temperature, min.	-50 °C
Operating temperature, max.	100 °C	Temperature range, installation, min.	-25 °C
Temperature range, installation, max.	100 °C		

**Rated data acc. to IEC**

tested acc. to standard	IEC 60664-1, IEC 61984	Rated current, min. no. of poles (Tu=20°C)	15.1 A
Rated current, max. no. of poles (Tu=20°C)	7.7 A	Rated current, min. no. of poles (Tu=40°C)	13 A
Rated current, max. no. of poles (Tu=40°C)	6.6 A	Rated voltage for surge voltage class / pollution degree II/2	320 V
Rated voltage for surge voltage class / pollution degree III/2	160 V	Rated voltage for surge voltage class / pollution degree III/3	160 V
Rated impulse voltage for surge voltage class/ pollution degree II/2	2.5 kV	Rated impulse voltage for surge voltage class/ pollution degree III/2	2.5 kV
Rated impulse voltage for surge voltage class/ contamination degree III/3	2.5 kV	Short-time withstand current resistance	3 x 1s with 100 A

# Data sheet

## OMNIMATE Signal - series BL/SL 3.50 BLL 3.50/02/180 3.2SN OR TU

**Weidmüller Interface GmbH & Co. KG**  
 Klingenbergstraße 16  
 D-32758 Detmold  
 Germany  
 Fon: +49 5231 14-0  
 Fax: +49 5231 14-292083  
 www.weidmueller.com

# Technical data

### Rated data acc. to CSA

Institute (CSA)				Certificate No. (CSA)	
				200039-1121690	
Rated voltage (Use group C / CSA)	300 V	Rated current (Use group C / CSA)	9 A		
Reference to approval values	Specifications are maximum values, details - see approval certificate.				

### Rated data acc. to UL 1059

Institute (cURus)				Certificate No. (cURus)	
				E60693	
Rated voltage (Use group B / UL 1059)	300 V	Rated voltage (Use group D / UL 1059)	300 V		
Rated current (Use group B / UL 1059)	9 A	Rated current (Use group D / UL 1059)	9 A		
Reference to approval values	Specifications are maximum values, details - see approval certificate.				

### Packing

Packaging	Tube	VPE length	15 mm
VPE width	20 mm	VPE height	555 mm
Surface resistance	$R_s = 10^9 - 10^{12} \Omega$		

### Classifications

ETIM 4.0	EC002637	ETIM 5.0	EC002637
ETIM 6.0	EC002637	eClass 6.2	27-26-07-04
eClass 7.1	27-44-04-02	eClass 8.1	27-44-04-02
eClass 9.0	27-44-04-02	eClass 9.1	27-44-04-02

### Notes

Notes	<ul style="list-style-type: none"> <li>• Additional colours on request</li> <li>• Gold-plated contact surfaces on request</li> <li>• Rated current related to rated cross-section &amp; min. No. of poles.</li> <li>• P on drawing = pitch</li> <li>• Rated data refer only to the component itself. Clearance and creepage distances to other components are to be designed in accordance with the relevant application standards.</li> </ul>
IPC conformity	Conformity: The products are developed, manufactured and delivered according international recognized standards and norms and comply with the assured properties in the data sheet resp. fulfill decorative properties in accordance with IPC-A-610 "Class 2". Further claims on the products can be evaluated on request.

**Data sheet**

**OMNIMATE Signal - series BL/SL 3.50  
BLL 3.50/02/180 3.2SN OR TU**

**Weidmüller Interface GmbH & Co. KG**  
Klingenbergstraße 16  
D-32758 Detmold  
Germany  
Fon: +49 5231 14-0  
Fax: +49 5231 14-292083  
www.weidmueller.com

**Technical data**

**Approvals**

Approvals



ROHS

Conform

**Downloads**

Approval/Certificate/Document of  
Conformity

[Declaration of the Manufacturer](#)

Brochure/Catalogue

- [FL DRIVES EN](#)
- [MB DEVICE MANUF. EN](#)
- [FL DRIVES DE](#)
- [CAT 2 PORTFOLIOGUIDE EN](#)
- [FL BUILDING SAFETY EN](#)
- [FL APPL LED LIGHTING EN](#)
- [FLIndustr.CONTROLS EN](#)
- [FL MACHINE SAFETY EN](#)
- [FL HEATING ELECTR EN](#)
- [FL APPL INVERTER EN](#)
- [FL\\_BASE\\_STATION\\_EN](#)
- [FL ELEVATOR EN](#)
- [FL POWER SUPPLY EN](#)
- [FL 72H SAMPLE SER EN](#)
- [PO OMNIMATE EN](#)

Engineering Data

[EPLAN\\_WSCAD](#)

Engineering Data

[STEP](#)

**OMNIMATE Signal - series BL/SL 3.50  
BLL 3.50/02/180 3.2SN OR TU**

**Weidmüller Interface GmbH & Co. KG**  
Klingenbergstraße 16  
D-32758 Detmold  
Germany  
Fon: +49 5231 14-0  
Fax: +49 5231 14-292083  
www.weidmueller.com

**Drawings**

**Dimensional drawing**

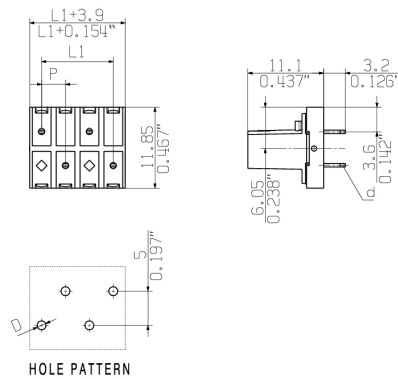

**Product benefits**



Connection made easy  
Safe board-to-board connection

MASSE OHNE TOLERANZ SIND KEINE PRUEFMASSE  
DIMS. WITHOUT TOLERANCE ARE NOT CONTROL DIMS.

DIE DEUTSCHE VERSION IST VERBINDLICH  
THE GERMAN VERSION IS BINDING

ALLGEMEINGUELTIGE KUNDENZEICHUNG, AKTUELLER STAND NUR AUF ANFRAGE  
GENERAL CUSTOMER DRAWING, TOPICAL VERSION ONLY IF REQUIRED

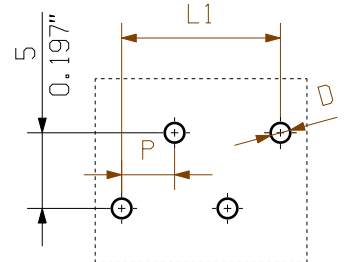
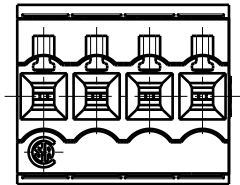
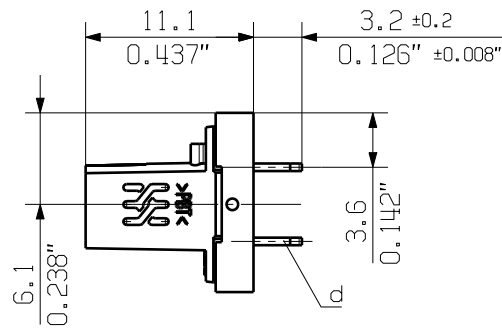

DETAIL A  
X 5/1



SHOWN : BLL 3.50/04/180

HOLE PATTERN

M 1/1

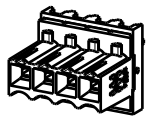

P=3.50 RASTER PITCH  
D=Ø1.3 +0.1  
d=0.5x0.8

For the mounting of PCBs, it should be noted that the rated data given in the catalogue relates only to the connection elements. The necessary creepage and clearance paths must be observed in connection with the respective applicant in accordance to VDE 0110. The current-carrying capacity and pitch tolerance is to be determined according to DIN IEC 326 part 3 very fine.

Weidmüller connectors are tested to the DIN VDE 0627 standard, and are valid for its field of application. Provided that the connectors are used to the intended purpose, all requirements with respect to the occurring of electrical, mechanical, thermic and corrosive stress will be satisfied.

n	POLZAHL POLES	L1 [mm]	L1 [inch]	REIHE/ ROW	1	2	3	4	5	6	7	8	9	10	11	12
12	38.5	1.516		1	X	0	X	0	X	0	X	0	X	0	X	0
				2	0	X	0	X	0	X	0	X	0	X	0	X
11	35.0	1.378		1	X	0	X	0	X	0	X	0	X	0	X	
				2	0	X	0	X	0	X	0	X	0	X	0	
10	31.5	1.240		1	X	0	X	0	X	0	X	0	X	0		
				2	0	X	0	X	0	X	0	X	0	X	0	
9	28.0	1.102		1	X	0	X	0	X	0	X	0	X			
				2	0	X	0	X	0	X	0	X	0			
8	24.5	0.965		1	X	0	X	0	X	0	X	0				
				2	0	X	0	X	0	X	0	X				
7	21.0	0.827		1	X	0	X	0	X	0	X					
				2	0	X	0	X	0	X	0					
6	17.5	0.689		1	X	0	X	0	X	0						
				2	0	X	0	X	0	X						
5	14.0	0.551		1	X	0	X	0	X							
				2	0	X	0	X	0							
4	10.5	0.413		1	X	0	X	0								
				2	0	X	0	X								
3	7.0	0.276		1	X	0	X									
				2	0	X	0									
2	3.5	0.138		1	X	0										
				2	0	X										

GENERAL TOLERANCE:  
DIN ISO 2768-m



80439/5  
17.02.15 HELIS\_MA 01

MODIFICATION

**Weidmüller**

CAT.NO.:  
**C 33133 14**

DRAWING NO. SHEET 01 OF 01 SHEETS  
ISSUE NO.



DATE NAME  
DRAWN 22.04.2005 FROEHLKING\_M

RESPONSIBLE CHECKED 17.02.2015 LANG\_T  
HELIS\_MA

SCALE: 2/1

SUPERSEDES: .

APPROVED LANG\_T

**BLL 3.50/.../180...**  
BUCHSENLEISTE  
FEMALE HEADER

PRODUCT FILE: BLL 3.50

7369

WEITERGABE SOWIE Vervielfaeltigung dieses Dokuments, Verwertung und Mitteilung seines Inhalts sind verboten, soweit nicht ausdruecklich gestattet. ZUWIDERHANDLUNGEN VERPFLICHTEN ZU SCHADENERSATZ. ALLE RECHTE FUER DEN FALL DER PATENT-, GEBRAUCHSMUSTER- ODER GESCHMACKSMUSTEREINTRAGUNG VORBEHALTEN. THE REPRODUCTION, DISTRIBUTION AND UTILIZATION OF THIS DOCUMENT AS WELL AS THE COMMUNICATION OF ITS CONTENTS TO OTHERS WITHOUT EXPLICIT AUTHORIZATION IS PROHIBITED. OFFENDERS WILL BE HELD LIABLE FOR THE PAYMENT OF DAMAGES. WEIDMUELLER EXCLUSIVELY RESERVES THE RIGHT TO FILE FOR PATENTS, UTILITY MODELS OR DESIGNS. WEIDMUELLER INTERFACE GmbH & Co.KG

## Recommended wave soldering profiles

**Weidmüller Interface GmbH & Co. KG**  
 Klängenbergstraße 16  
 D-32758 Detmold  
 Germany  
 Fon: +49 5231 14-0  
 Fax: +49 5231 14-292083  
 www.weidmueller.com

### Single Wave:



### Double Wave:



### Wave soldering profiles

Wired connection elements should be processed in accordance with the DIN EN 61760-1 standard. We have included two recommendations for practical wave soldering profiles, with which Weidmüller PCB terminals and connectors are qualified.

When choosing a suitable profile for your application, the following factors also need to be considered:

- PCB thickness
- Proportion of Cu in the layers
- Single/double-sided assembly
- Product range
- Heating and cooling rates

The single and double wave profiles each indicate the recommended operating range, including the maximum soldering temperature of 260°C. In practice, the maximum soldering temperature is quite often well below the above maximum profile.