



extension kit for mechanical transmission of switch position, side wall, for fixed-mounted circuit breaker in rear wall fixing accessories for circuit breakers 3WL10 / 3VA27

Model	
product brand name	SENTRON
product designation	expansion kit for mechanical breaker position pickoff
design of the product	for fixed-mounted breakers, rear panel mounted
Accessories	
accessories	Accessories for 3WL10 / 3VA27 circuit breakers
Mechanical Design	
height	40 mm
width	280 mm
depth	180 mm
Net Weight	474 g

Approvals Certificates		
Environment	General Product Approval	Maritime application

[Environmental Con-
firmations](#)



[Confirmation](#)



other

[Confirmation](#)



Further information

- Information on the packaging
<https://support.industry.siemens.com/cs/ww/en/view/109813875>
- Information for data generation and storage
<https://support.industry.siemens.com/cs/ww/en/view/109995012>
- Information- and Downloadcenter (Catalogs, Brochures,...)
<https://www.siemens.com/lowvoltage/catalogs>
- Industry Mall (Online ordering system)
<https://mall.industry.siemens.com/mall/en/en/Catalog/product?mlfb=3VW9011-0BB53>
- Service&Support (Manuals, Certificates, Characteristics, FAQs,...)
<https://support.industry.siemens.com/cs/ww/en/ps/3VW9011-0BB53>
- Image database (product images, 2D dimension drawings, 3D models, device circuit diagrams, ...)
https://www.automation.siemens.com/bilddb/cax_en.aspx?mlfb=3VW9011-0BB53
- CAX-Online-Generator
<https://www.siemens.com/cax>
- Tender specifications

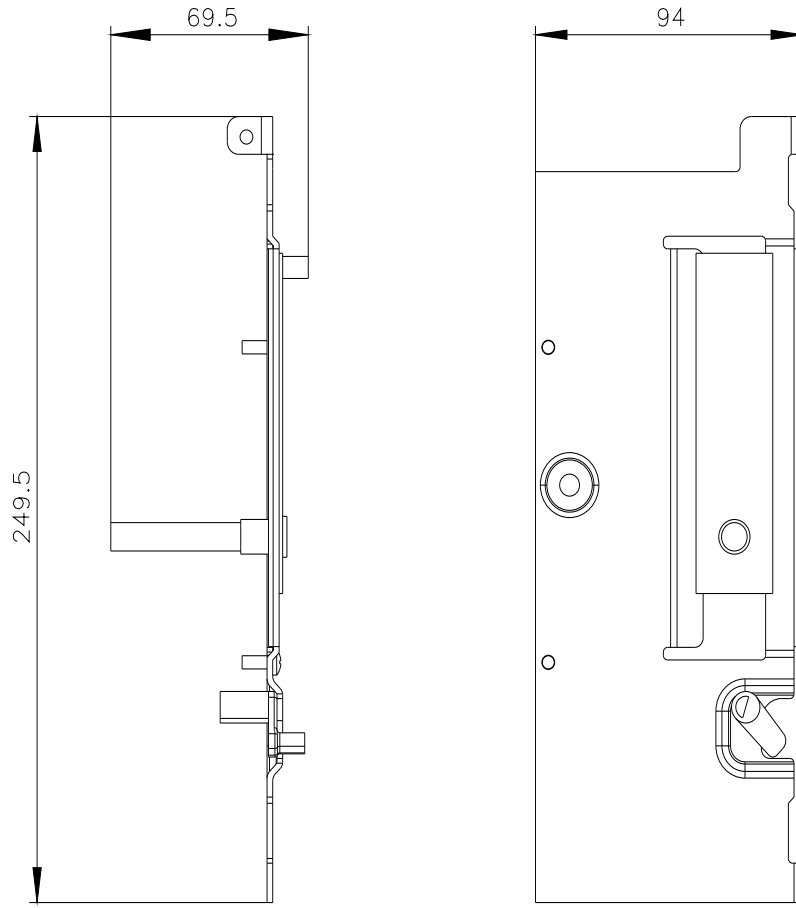

last modified:

4/4/2025 

