



INDUSTRIAL SHIELDS

DIN Rail Power Supply Unit

120W, 24V Output



- Universal Input 90 - 264 Vac
- 100% Full Load Burn-in test
- Cooling by Free Air convection
- Led Indicator for DC Power ON and for DC Low
- Protections against: Short Circuit, Over Voltage, Over Current and Over Temperature.

Power Supply Unit

Revised January 2020

Preface

This User Guide is been implemented by Boot & Work, S.L. working under the name Industrial Shields.

Purpose of the manual

The information contained in this manual can be used as a reference to operating, to functions, and to the technical data of the signal modules, power supply modules and interface modules.

Intended Audience

This User Guide is intended for the following audience:

- Persons in charge of introducing automation devices.
- Persons who design automation systems.
- Persons who install or connect automation devices.
- Persons who manage working automation installation.

Intended use or of Industrial Shields products

Consider the following:

Industrial Shields products should only be used for the cases of application foreseen in the catalogue and the associated technical documentation. If third-party products and components are used, they must have been recommended or approved by Industrial Shields.

The correct and safe operation of the products requires that your transport, storage, installation, assembly, operation and maintenance have been carried out in a correct It must respect the permissible ambient conditions. You should also follow the indications and warnings that appear in the associated documentation.

The product / system dealt with in this documentation should only be handled or manipulated by qualified personnel for the task entrusted and observing what is indicated in the documentation corresponding to it, particularly the safety instructions and warnings included in it. Due to their training and experience, qualified personnel are in a position to recognize risks resulting from the handling or manipulation of such products / systems and to avoid possible hazards.

Disclaimers

Weights and Dimensions

Dimensions and weights are nominal and they are not used for manufacturing purposes, even when tolerances are shown.

Performance Data

The performance data given in this manual is provided as a guide for the user in determining suitability and does not constitute a warranty. It may represent the result of INDUSTRIAL SHIELDS's test conditions, and the users must correlate it to actual application requirements. Actual performance is subject to the INDUSTRIAL SHIELDS Warranty and Limitations of Liability.

Change in Specifications

Product specifications and accessories may be changed at any time based on improvements and other reasons.

It is our practice to change model numbers when features are changed, or published ratings or when significant construction changes are made. However, some specifications of the

products may be changed without any notice. When in doubt, special numbers may be assigned to fix or establish key specifications for your

application on your request. Please consult with your INDUSTRIAL SHIELDS representative at any time to confirm actual specifications of purchased products.

Errors and Omissions

The information in this document has been carefully checked and is believed to be accurate; however, no responsibility is assumed for clerical, typographical, or proofreading errors, or omissions.

These components may only be operated in closed housings or in higher-level control cabinets with protective covers that are closed, and when all of the protective devices are used. These components may only be handled by qualified and trained technical personnel who are knowledgeable and observe all of the safety information and instructions on the components and in the associated technical user documentation. When carrying out a risk assessment of a machine in accordance with the EU Machinery Directive, the machine manufacturer must consider the following residual risks associated with the control and drive components of a PDS.

Table of Contents

General Description	5
1.1. Electrical	5
1.2. Input Parameters	5
1.3. Output Parameters	6
1.4. Protection	6
1.5. Mechanical dimension	7
1.6. Serigraphy	7
Operating Specifications:	8
2.1. Environment	8
2.2. Safety/EMC	8
Applications and Maintenance	9
3.1. Series Operation	9
3.2. Parallel Operation	10
3.3. Din Rail Mounting	11



1 General Description

1.1. Electrical

Nominal Input Voltage	Output Voltage	Output Current	Ripple (Typ.)	Efficiency (Typ.)	Certificate
100-240 Vac	24 Vdc	5 A	120 mV	85%	CE, FCC, CB, UL, CUL

1.2. Input Parameters

PARAMETER	CONDITIONS	MIN	TYP	MAX	UNITS
Input Voltage		90		264	Vac
Input Frequency		47		63	Hz
Input Current	Full load, Vin=115Vac			2.6	A
	Full load, Vin = 230Vac			1.3	A
Inrush Current	Cold start, Vin = 115Vac			30	A
	Cold start, Vin = 230Vac			60	A
Inrush Current	<p>1. This product is built inrush limiting circuit to protect the circuit from surge current damages when the power is turned on. Malfunction can occur by repeating the input voltage on and off rapidly. Therefore, sufficient interval should be given between turning on and off the power;</p> <p>2. To avoid connecting the switch or fuse to input terminal (outside of the power supply), more consideration should be given when selecting the parts that can endure the inrush current.</p>				
Stand-by power consumption	Vin = 230Vac			4	W
Surge voltage	L-N			2	KV

1.3. Output Parameters

PARAMETER	CONDITIONS	MIN	TYP	MAX	UNITS
Output Voltage accuracy				2	%
Output Voltage adjustment range			23-28		Vdc
	Output voltage can be adjusted within above range by V-ADJ. variable resistance inside of the power supply. When output voltage exceeds the range, the power supply will be in failure or get into over voltage protection mode. To avoid the case that the output voltage is higher than rated voltage, output current should be used under rated current.				
Minimum Load		0			A
Line regulation	Vin from 100 Vac to 240 Vac			2	%
Stand-by power consumption	Vout from min. to max.			2	%
Turn-on delay time	Full load, Vin = 115 Vac		560		ms
Hold up time	Full load, Vin = 115 Vac		20		ms

1.4. Protection

Short Circuit	Hiccup mode, it will recover automatically after fault condition is removed
Over Voltage	Over Voltage protection value 33V
	(1) When output voltage exceeds above over voltage protection value or reversal voltage occurs, the protection will be started and the output voltage will be cut off in order to protect the power supply; (2) The power supply will recover after the power is turned on again
Over Current	Over Current protection value 6.6 A
	(1) When output voltage exceeds above over current protection value, the protection will be started and the output voltage will be cut off in order to protect the power supply; (2) The power supply unit will recover automatically after the fault condition is removed.
Over Temperature	Over Temp. protection value: 100 ± 10°C
	(1) When the ambient temperature exceeds above our temperature protection value, the protection will be started and the output voltage will be cut off in order to protect the power supply; (2) The power supply unit will recover after the power is turned on again.

1.5. Mechanical dimension

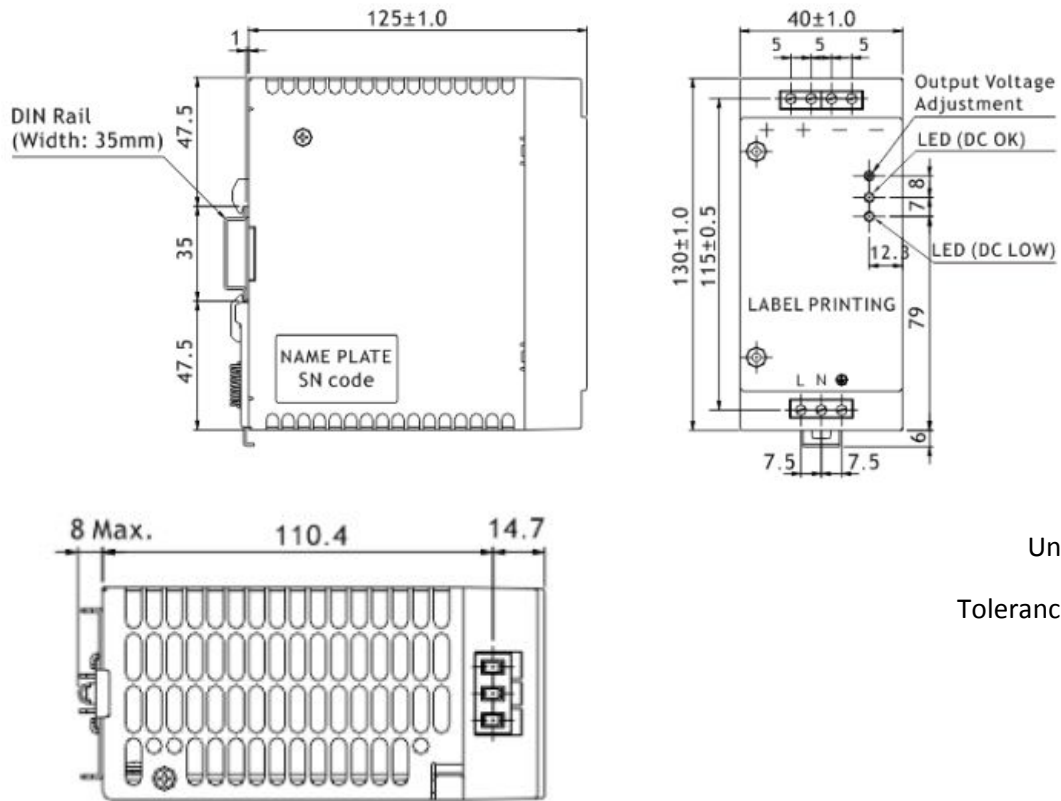

1.6. Serigraphy



Marking	No.	Assignment
+	1	DC(+) Output Terminal
+	2	
-	3	DC(-) Output Terminal
-	4	
L	5	AC(L) Input Terminal
N	6	AC(N) Input Terminal
⊕	7	AC Grounding Terminal
V-ADJ.	/	DC Output voltage adjustment trimmer
DC OK	/	DC Output OK indication LED(Green)
DC LOW	/	DC Output Low indication LED(Red)

2 Operating Specifications:

2.1. Environment

PARAMETER	CONDITIONS	MIN	TYP	MAX	UNITS
Ambient Operating temperature	Startup at rated voltage	-25		70	°C
Operating Relative humidity	Non Condensing	20		95	%
Storage Temperature	Humidity 5 - 95% RH	-40		85	°C
MTBF	Full load, 220Vac input, 25°C ambient temperature	200			Khrs
DC-OK led	LED (Green) DC OK LED light will be ON when the power supply is properly operated				
DC-Lowled	LED (Red) DC Low LED Light will be ON: (1) When output voltage is below 85%(±2.5%) from the rated output voltage; (2) When get over voltage, over current, over temperature and short circuit fault				
Cooling	Free air convection				
Mounting Method	Vertical				
Dimensions (WxHxD)	40.0 x130.0 x 125.0 mm (1.57 x 5.12 x 4.92 inch)				
Weight	800g				
Packing	15pcs / 13.5Kg / 0.7cuft / carton Carton size 620x260x175 mm (L x W x H)				

2.2. Safety/EMC

Isolation Voltage	I/P-O/P: 3KVac ,I/P-FG: 1.5 KVac, O/P-FG: 1.5 KVac
Insulation Resistance	100MΩ Max. / 500Vdc
Safety	Design refer to UL60950-1, EN60950-1

EMC	EN 55032:2010+AC:2011 (CISPR 22:2008) ClassA EN 61000-3-2:2014 (IEC 61000-3-2:2014) EN 61000-3-3:2013(IEC 61000-3-3:2013) EN 55024:2010(CISPR 24:2010)
------------	---

3 Applications and Maintenance

3.1. Series Operation

Series Operation can be connected as shown:

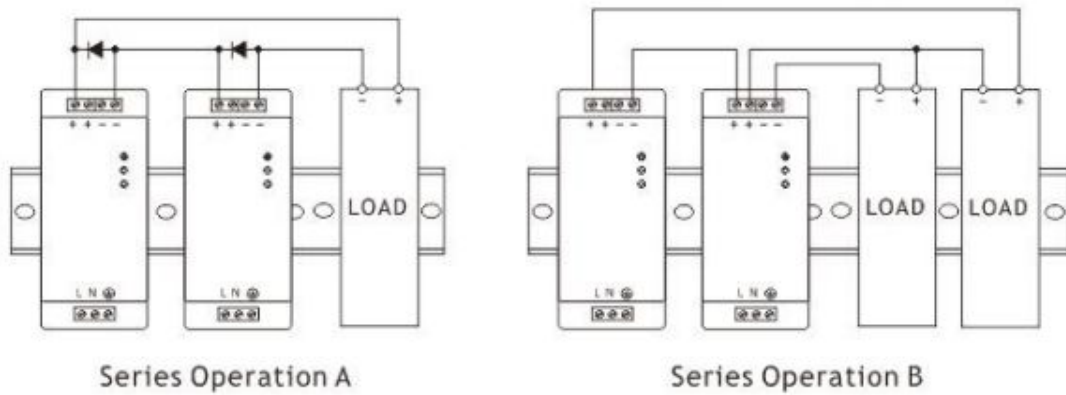

Load current should be less than the current value of the product with the lowest output current specified at the product specification with the Power Supply at series connection.

3.2. Parallel Operation

Do not connect the power supplies as follows:

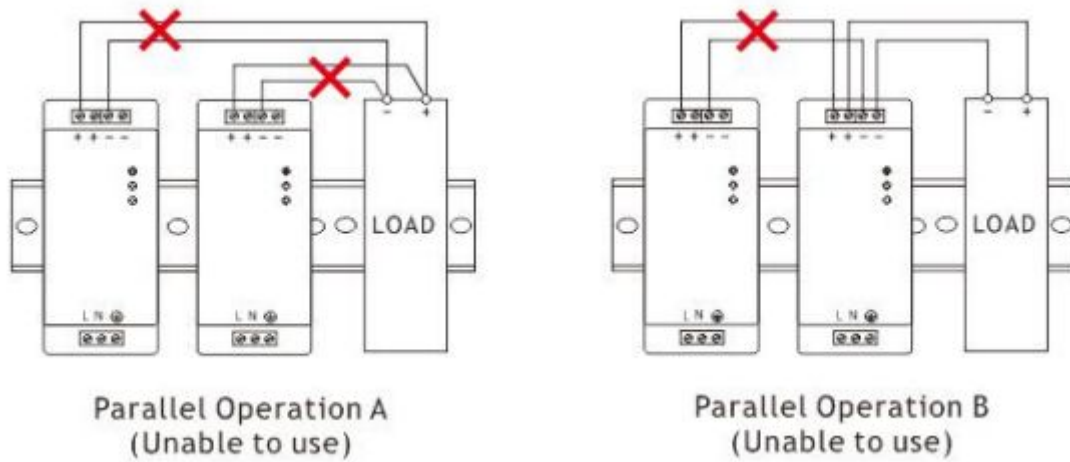

Parallel operation should be composed with the same products, while the connection should be as “Parallel operation C”;

2. In Parallel operation C, current capacity cannot be increased, while it should be used for backup only. Moreover, diode that is to be added during parallel operation should be selected after considering its voltage drop, output voltage and current capacity.

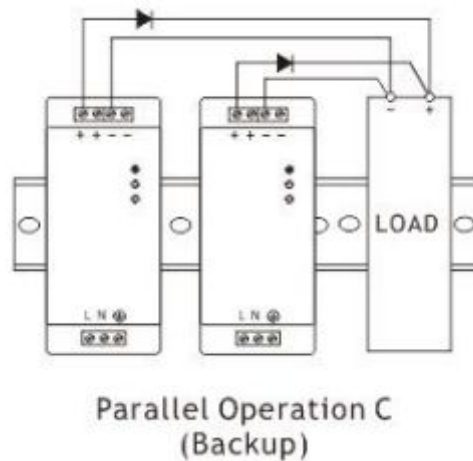

3.3. Din Rail Mounting

Hang part A on the top of the Rail as shown below, then push into B direction to fix it on the DIN Rail.

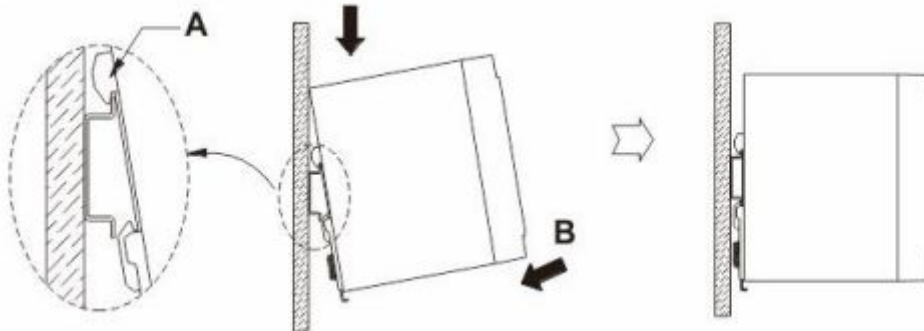

Remember to leave a minimum of 25mm between both PSU or between the PSU and another device located inside the cabinet. Forced air cooling makes protection against heat better.

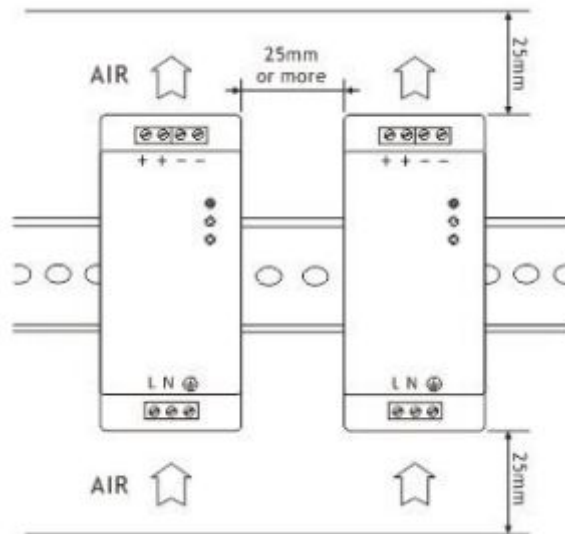

About Industrial Shields:

Direction: Fàbrica del Pont, 1-11

Zip/Postal Code: 08272

City: Sant Fruitós de Bages (Barcelona)

Country: Spain

Telephone: (+34) 938 760 191 / (+34) 635 693 611

Mail: industrialshields@industrialshields.com