

ALPHA2

Programmable Logic Controller

Beginner's Manual

About this manual

The texts, images, diagrams and examples in this manual serve only to clarify the installation, operation, programming and use of PLCs from the ALPHA series.

In in doubt about the installation and operation of the devices described in this manual, do not hesitate to contact your appropriate sales office or one of your distributors (see cover page). Please go to the Web (www.mitsubishi-automation.de) for current information as well as answers to the most frequently asked questions.

MITSUBISHI ELECTRIC EUROPE B.V. reserves the right to make technical changes to this manual at any time without special notice.

© 2005–2009

Safety Guidelines

Target Group

This manual is aimed solely at properly trained electricians who are familiar with the safety standards of automation technology. Only a properly trained electrician familiar with the safety standards of automation technology may design, install, start up, service and test devices. Corrections made to our product hardware and software, unless they are described in this manual, may be done only by our specialist staff.

Intended Use

PLCs from the ALPHA series are intended only for the scopes of application described in this manual. Please make sure to comply with all the characteristics indicated in this manual. The products were developed, manufactured, tested and documented in compliance with safety standards. Unqualified corrections in hardware or software or noncompliance with the warnings given in this manual or attached to the product can lead to serious personal injuries or property damage. Use only accessories or add-ons recommended by MITSUBISHI ELECTRIC in conjunction with the PLCs from the ALPHA series.

Any application or usage that goes beyond this is considered unintended use.

Safety Regulations

Comply with the safety and accident prevention regulations applicable to specific applications when designing, installing, starting up, servicing and testing devices. In particular, adhere to the following regulations (not an exhaustive list):

● VDE regulations

- VDE 0100
Regulations for setting up high-voltage equipment with nominal voltages up to 1000 V
- VDE 0105
Operation of power installations
- VDE 0113
Electrical devices with electronic operating controls
- VDE 0160
Equipment of power installations and electronic operating controls
- VDE 0550/0551
Requirements for transformers
- VDE 0700
Safety of electrical devices for household application and similar purposes
- VDE 0860
Safety requirements for line-powered electronic devices and related apparatus for household use and similar purposes

● Fire prevention regulations

● Accident prevention regulation

- VBG No. 4
Electrical devices and operating controls

Hazard Warnings

The individual warnings have the following meaning:



DANGER:

Means that a danger to the life and health of the user exists if the appropriate precautionary measures are not taken.



ATTENTION:

Means a warning against possible damage to the device or other properties if the appropriate precautionary measures are not taken.

General Hazard Warnings and Safety Precautions

The following hazard warnings are to be understood as general guidelines for handling PLCs together with other devices. These warnings must be heeded when designing, installing and operating a control device.



DANGER:

- *Follow the safety and accident prevention regulations applicable to the specific instance of use. The mounting, wiring and opening of modules, components and devices must be done in de-energized state.*
- *Install modules, components and devices in a touch-proof housing with a proper cover and protective mechanism.*
- *For devices with a stationary power connection an all-pole line disconnecter and a fuse must be built into the building installation.*
- *Check live cables and lines with which the devices are connected regularly for insulation errors or ruptures. If an error in the cabling is discovered, immediately disconnect the devices and cabling from the voltage supply and replace the defective cabling.*
- *Prior to startup check whether the permissible line voltage range coincides with the local line voltage.*
- *Take the appropriate safety precautions to prevent a line or wire break on the signal side from leading to uncertain states.*
- *Take the necessary precautions to be able to restart properly an interrupted program after voltage falls and losses. When this happens no hazardous operating conditions should arise even for a short time.*
- *As per DIN VDE 0641 part 1-3 residual current circuit breakers together with PLCs as sole protection upon indirect contact are not adequate. For this reason, additional or other protective measures must be taken.*
- *In accordance with EN60204/IEC 204 VDE 0113 emergency stop devices must be operative in all operating modes of the PLC. Releasing the emergency stop device must not cause any uncontrolled or undefined restarting.*
- *Take the appropriate safety precautions in the hardware and software to prevent a line or wire break on the signal side from leading to uncertain states in the control.*
- *Ensure strict adherence to electrical and physical characteristics at all times when using modules.*

Content

1	Introduction	
1.1	What are the advantages of small control?	1-1
1.2	What is especially remarkable about ALPHA small control?	1-3
2	Basics	
2.1	What exactly is small control?	2-1
2.2	My controller processes what type of signals?	2-2
2.3	How are signals processed?	2-2
3	System Structure	
3.1	How is the ALPHA control structured?	3-1
3.2	This is how I mount my control	3-2
3.3	How do I connect my control?	3-2
4	Selection of Control	
4.1	From idea to the appropriate control	4-1
4.2	This is how I find the right control for myself	4-2
5	Programming	
5.1	What is a program?	5-1
5.2	Basic logic functions	5-2
5.3	Expanded functions	5-2
5.4	Converting a control task into a program	5-5
5.5	Inputting the program	5-6

6	Programming Examples	
6.1	Outdoor lighting	6-1
6.2	Stairwell light	6-6
6.3	Roller shutter control	6-9
6.4	Control of conveyor belts	6-13
6.5	Ventilation of an underground garage	6-17
7	Expansion Options	
7.1	Expansion modules and memory cassettes	7-1
7.2	Communication options	7-3

1 Introduction

1.1 What are the advantages of simple application controllers?

Multifunctional controller

With its ALPHA simple application controller product line, Mitsubishi Electric offers a multifunctional controller where you can solve a multitude of control tasks by simply selecting one of the integrated functions.

Time-saving, space-saving and cost-saving

The ALPHA controller makes single components such as relay, timers, clock, event counter, running time meter, integrated clock, comparator, hysteresis controller and many more available to you in one single device.

However, the fusion of functions in one device does not only mean less space requirement but also especially significant cost savings in development, assembly, wiring and material sourcing. The purchase cost of the smallest ALPHA, for example, is hardly more than that of a professional timer but it has four integrated timers and accomplishes several times more than a simple timer.

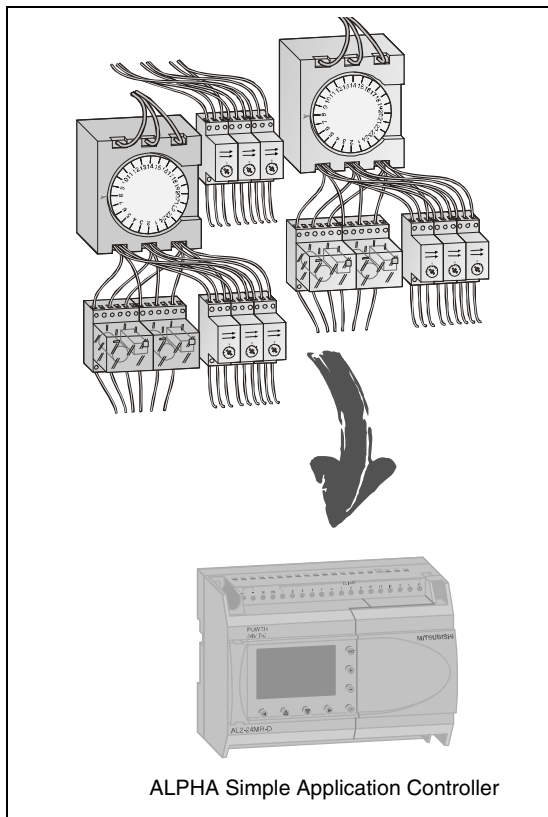

Fig. 1-1:
Many functions combined in one device

Simple to program

All functions can be set up by programming on the device or by means of a user-friendly software via a separate personal computer. You can forget old cost-intensive and time-consuming wiring solutions once and for all. Once the application changes, the control task is integrated more comprehensively later on or additional functions should be integrated later. This is easily done by making changes in the program or through expansion modules. With a simple ALPHA controller you can achieve an yet unknown degree of flexibility.

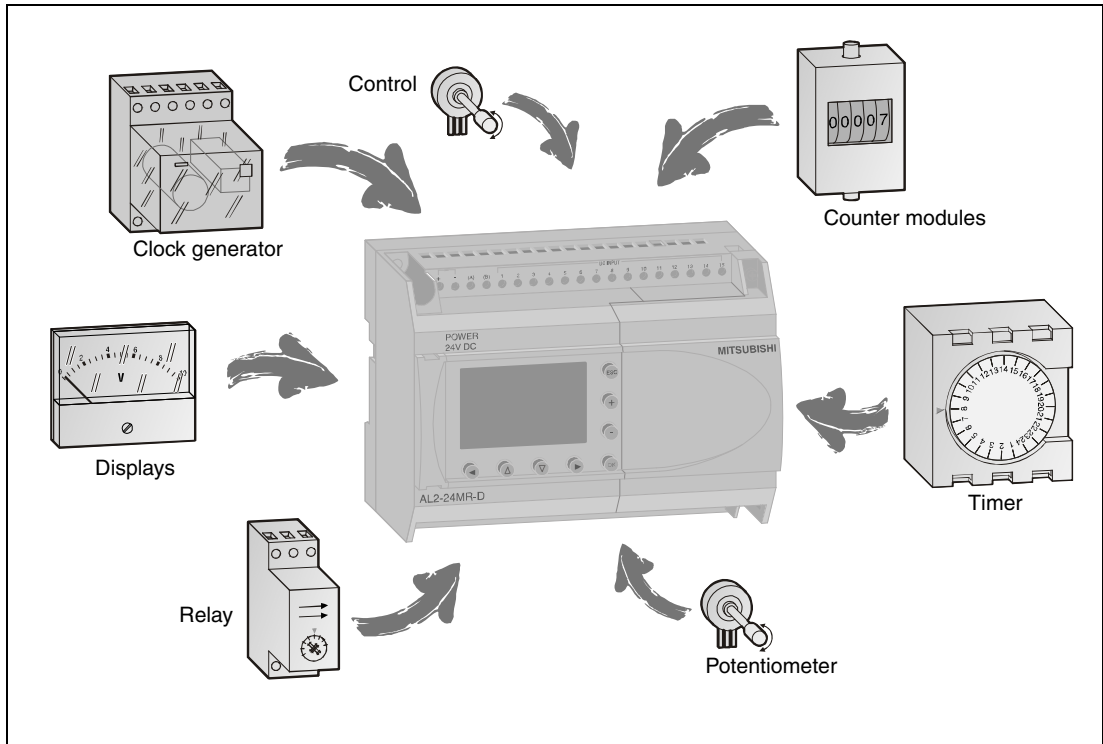

Fig. 1-2: Various programmable functions

1.2 What is especially remarkable about ALPHA controllers?

Control and display unit in one

The ALPHA controller is not only a multifunctional device for switching, controlling and regulating but also has a built-in display unit through which the program can be inputted and changed and through which information about all processes can be displayed.

This is not an inflexible display but a device where you can determine yourself what is shown on it. It is, for example, conceivable to display descriptive texts, switching states, counter values, analog values, times of day and operating times, etc. In addition, the function of buttons on the front panel can be linked to the program and freely defined so that you can input values while interacting with the display or change switch states. So what you have with the ALPHA is a small controller and panel with display in one device.

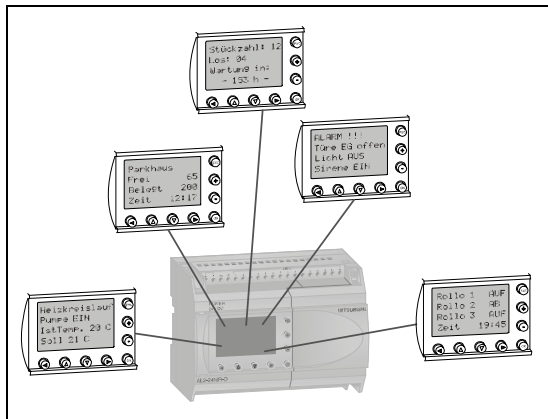

Fig. 1-3:
Control panel and display unit

Universally and flexibly applicable

ALPHA controllers were designed to be applicable almost universally. Apart from private households and residential buildings, the ALPHA can be used in industry, in public buildings such as shopping centers, processing operations, nurseries, banks, offices and many others.

The areas of application go from lighting, heating, air-conditioning, ventilation to alarm systems, access controls, gate controls as well as small machines, watering systems, energy management, etc. Customization to the respective working area is just done through the program.

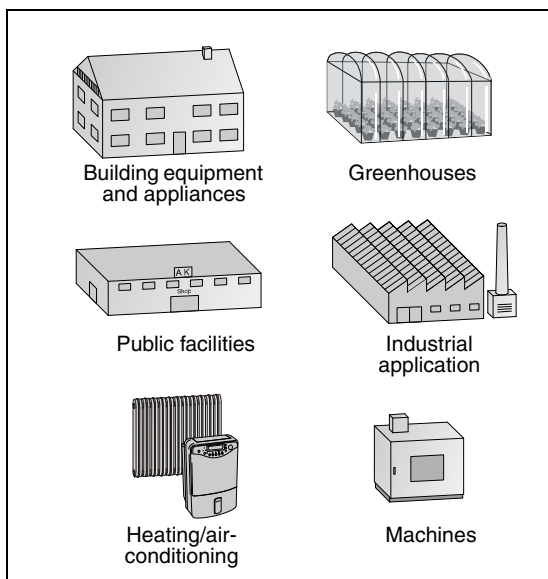

Fig. 1-4:
Various areas of application

2 Basics

2.1 What exactly is a small application controller?

A controller is a system where one or more input quantities are recorded and processed internally by the system, thereby affecting various output quantities.

Signals such as switching states are entered via control inputs, processed in the controller by a program and forwarded to outputs to be switched. Controls work according to the information processing principle where data is always inputted, processed and the processing results output. They therefore have:

- an input level,
- a processing level and
- an output level.

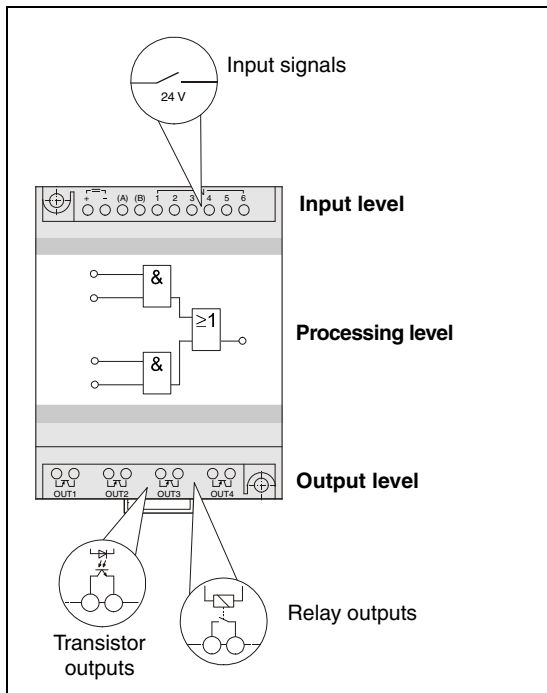

Fig. 2-1:
Information processing principle

Input level

The input level has the task of delivering control signals to the processing level. Typical components are switches, buttons and sensors. The signals of these components originate in the control process and are thus delivered as logical state of the input level. The input level delivers the signals in processed form to the processing level.

Processing level

The signals recorded and processed by the input level are processed in the processing level by a saved program and logically linked. The processing level has a program memory that is freely programmable. Changing the processing operation is possible at any time by changing or exchanging the saved program.

Output level

The results of the logic operation of the program from the processing level as output signals can affect the control of actuators of physical parameters.

The signals delivered by the processing level are processed for the control of outputs since voltage level and carrying capacity of processing and output levels differ from each other. What happens then in the output level is a signal adjustment via the so-called output interface which carries out power amplification and energy conversion.

2.2 My controller processes what type of signals?

Binary input signals

We basically distinguish between two signal states: ON and OFF or "1" and "0". Switching states are triggered in the output level of the controller depending on the binary input signals.

Binary signals can be realized by switching contacts (pushbuttons, relays, contactors, etc.) contactless with semiconductors (transistors) or with other controllers or switch elements.

Analog input signals

An input signal can appear as an analog signal with a continuously variable range. Analog signals, for example, can be delivered by a potentiometer in the form of a variable electrical voltage. The analog value is converted into a digital value and is available for internal processing.

ALPHA controllers with DC voltage supply offer the possibility of processing analog signals from 0 to +10 V.

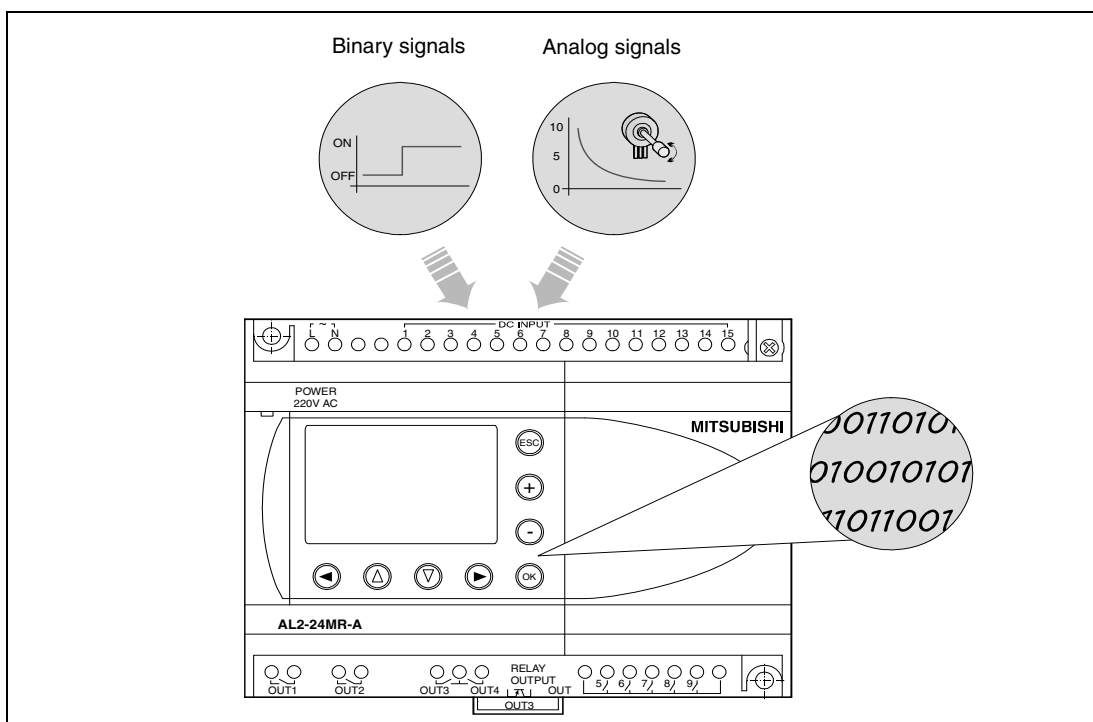

Fig. 2-2: Internal processing of signals by program

2.3 How are signals processed?

As already described above, input signals are processed in the processing level of the ALPHA controller by means of the saved program. The program or the "software" here uses so-called function blocks. These function blocks process every input or output as well as internal functions such as time function elements, counters, auxiliary switches, etc.

These functions can then be retrieved or addressed and logically linked to each other in the control program. More about this in Chapter 5.

3 System Structure

3.1 What is the structure of the ALPHA controller?

The ALPHA controller has a terminal block for input signals and a terminal block for outputs.

The usual buttons, switches, brightness and temperature sensors, motions sensors, etc. can be connected to the input terminals with the switching contact. In addition, some ALPHA controllers have the option of connecting analog signal transmitters such as thermal sensors, pressure gauges, moisture meters, etc. that output a variable voltage signal.

In devices with relay outputs you can connect electric loads to be controlled such as lamps, pumps, jalousie motors, fans or valves directly to the outputs.

All ALPHA controllers also have a connection for a personal computer through which the control can be easily programmed.

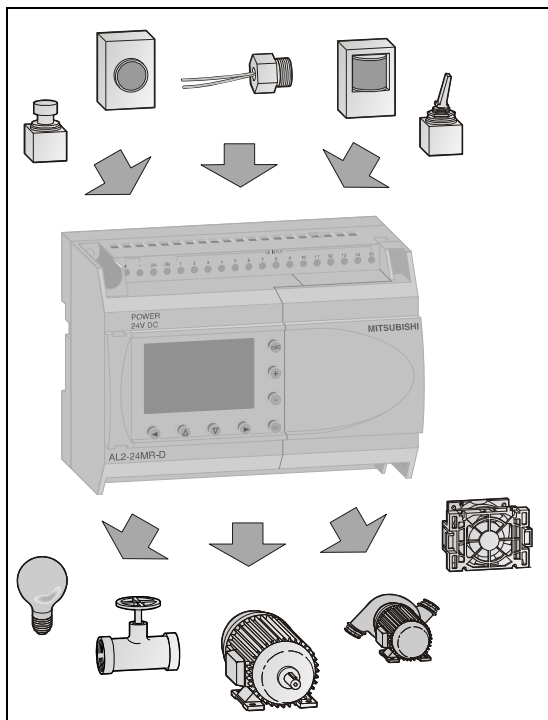

Fig. 3-1:
Connection of signal transmitters and peripheral equipment

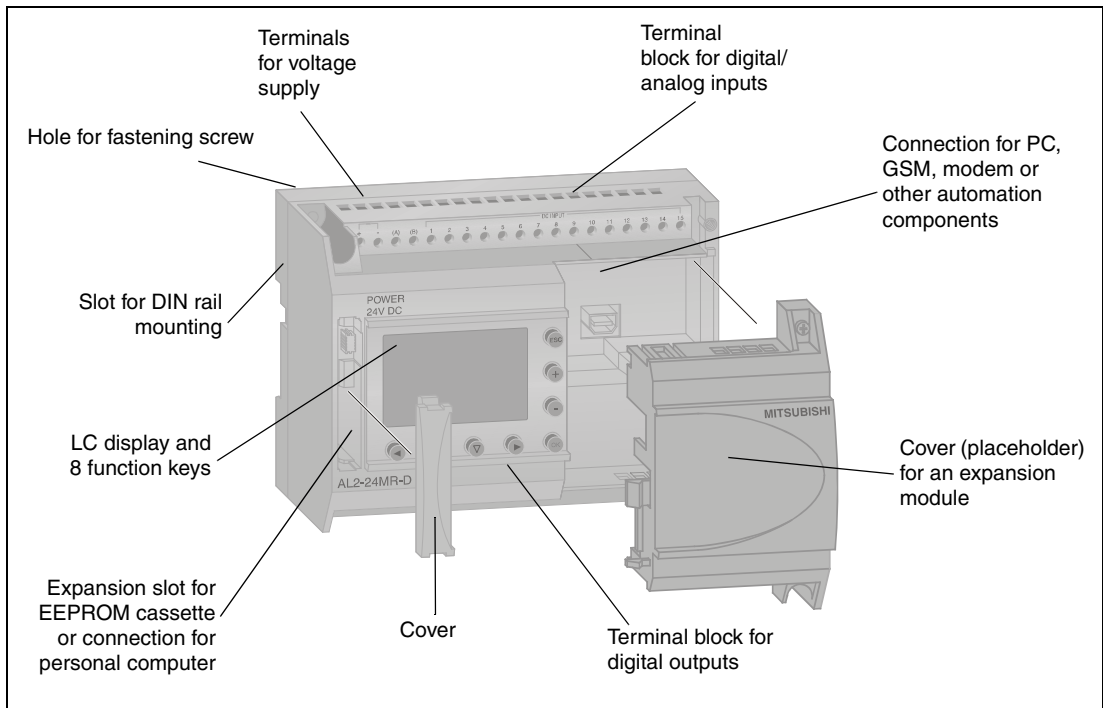

Fig. 3-2: Description of control

3.2 This is how I mount my controller

Using the integrated DIN rail adapter fasten the basic device on a DIN rail (top-hat rail) in the switch cabinet.

Make sure that the controller locks securely onto the DIN rail.

Alternatively you can fasten the control to an even base using suitable fastening screws.

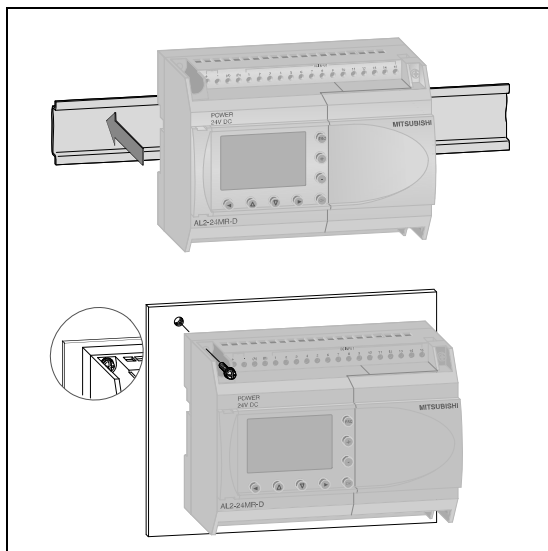

Fig. 3-3: Fastening options

3.3 How do I connect my controller?

Be sure to cut off the corresponding voltage source before connecting the voltage supply!

Unscrew the terminal screws and insert the insulated cable ends into the terminal screws. Make sure the screws are securely fitted!

Then carry out the wiring of the inputs and outputs. You can connect the usual buttons, switches or sensors directly to the inputs. You can connect electric loads to be controlled such as lamps, pumps, roller shutter motors, valves, etc. directly to the outputs. In any case, be sure that the current consumption of the electric load does not exceed the maximum current carrying capacity of the output.

Afterwards connect the supply voltage. Pay special attention to correct polarity in DC voltage modules!

After successful assembly check all connections once again and switch on the supply voltage. If the supply voltage is correctly connected the LC display must light up.

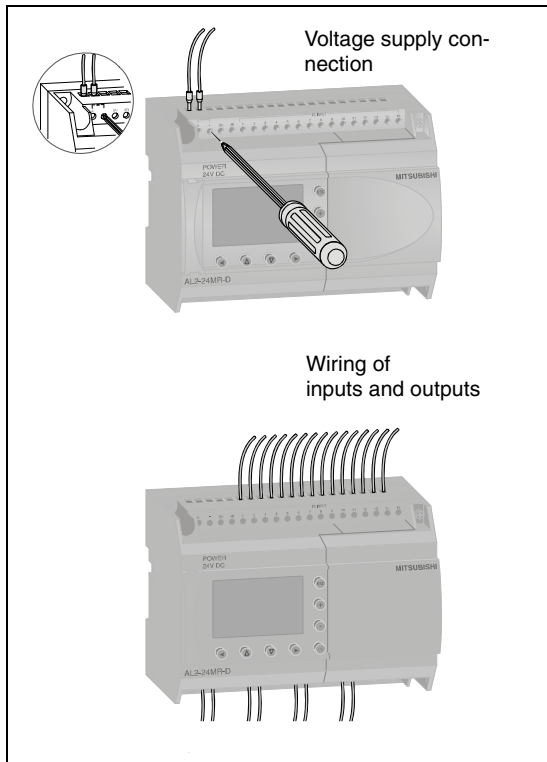

Fig. 3-4:
Wiring of terminals

4 Selection of Controller

4.1 From idea to the appropriate controller

Controls are available in different versions in terms of voltage supply and the choice of inputs and outputs. To find the control type that matches your intended use, you must first be clear how many electric loads or switching functions should be controlled and how much varying input data you must enter for the planned control operation.

The table below contains an overview of controller types that are currently available, listed according to voltage supply and number of inputs/outputs. On the following page you will find a help section for selecting the right controller for you.

The basic differences are the voltage supply connections. All modules with DC voltage supply also offer the possibility of detecting analog signals on the inputs.

Unoccupied inputs or outputs can be used for later expansions of the controller's task. However, even when all inputs and outputs are occupied, the capacity in the ALPHA2 can be expanded using expansion modules.

Voltage supply	Output type	ALPHA	Digital	Analog inputs	Outputs	Switching capacity
100–240 V AC	Relay outputs	AL2-10MR-A	6	—	4	Max. 8 A 375 VA (in 250 V)
		AL2-14MR-A	8	—	6	
		AL2-24MR-A	15	—	9	
24 V DC	Relay outputs	AL2-10MR-D	6	6	4	Max. 8 A 375 VA (in 250 V)
		AL2-14MR-D	8	8	6	
		AL2-24MR-D	15	8	9	

Tab. 4-1: Overview of types

Areas of application

While, for example, the "small" ALPHAs such as the AL2-10MR-A are perfectly suitable for simple applications such as those found in household appliances and building equipment, the "large" ALPHA can solve more complex tasks such as machine or process controls in the industrial field.

Please refer to Chapter 7 for more information about expansion and extension options for the ALPHA.

4.2 This is how I can find the right controller for myself

The following table should simplify the selection of the right controller for you. The answers to the following questions will help you to quickly find the required controller (see column ④).

Whether you are looking for a self-sufficient system for simple switching tasks or wish to solve more complex tasks, ALPHA2 is always the right choice.

- ① How many signals, i.e. external switch contacts, buttons and sensors, must be detected?
- ② How many functions or electric loads must be switched?
- ③ Which voltage supply is available?
- ④ This is the right controller for you!

	①	②	③			④
Type	Number of inputs	Number of outputs	Voltage supply	Output type	Max. switching capacity per output terminal	Controller
ALPHA 2	6	4	100–240 V AC	Relay	8 A in 250 V AC/30 V DC	AL2-10MR-A
	8	6	100–240 V AC	Relay	8 A in 250 V AC/30 V DC	AL2-10MR-D
	8	6	100–240 V AC	Relay	8 A in 250 V AC/30 V DC	AL2-14MR-A
	8	6	12–24 V DC	Relay	8 A in 250 V AC/30 V DC	AL2-14MR-D
	15	9	100–240 V AC	Relay	8 A in 250 V AC/30 V DC	AL2-24MR-A
	15	9	12–24 V DC	Relay	8 A in 250 V AC/30 V DC	AL2-24MR-A

Tab. 4-2: Selection aid

5 Programming

5.1 What is a program?

The program of a controller can be compared to the wiring of a conventional machine. While switches, contactors and indicator lamps there, for example, are connected to each other according to the control task, the function of the ALPHA controller is specified with the program.

However, to program the ALPHA controller you do not need to learn any complicated programming language. Preprogrammed function blocks simplify the solution even of complex control tasks.

A function block has one or more inputs and one output. The input signals are detected, processed according to function and the result output at the output of the function block.

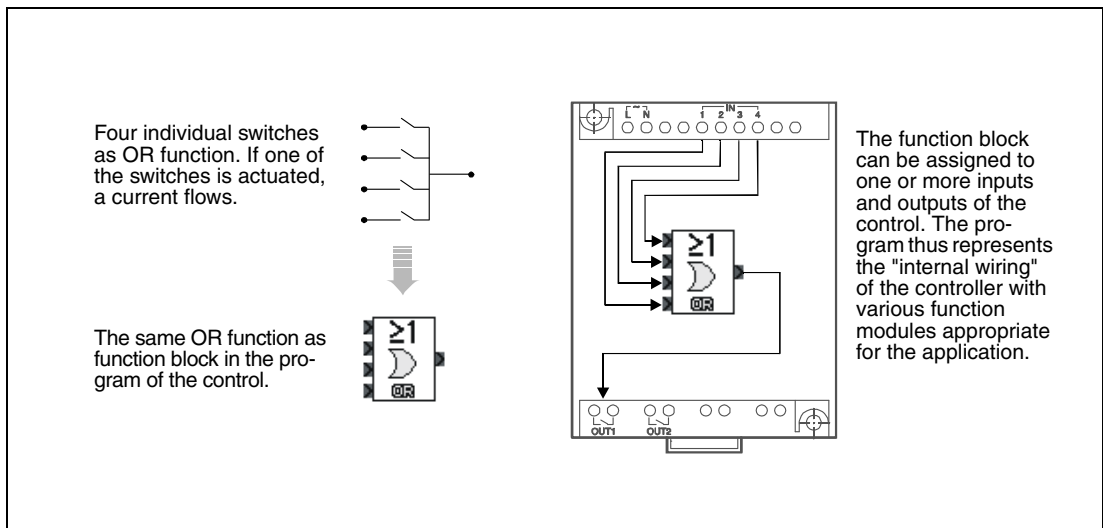

Fig. 5-1: Meaning of a function block

During programming the desired function (such as the user-friendly control of stairwell lighting) is divided into individual functions that can be implemented with function blocks. To implement the entire function, link the individual function blocks and you will obtain the program.

Incidentally, the ALPHA controller can be programmed with the integrated control panel buttons. In addition, the software called AL-PCS/WIN-EU for personal computers with Microsoft Windows interface is available. This simplifies the programming because of the graphical representation of the function blocks.

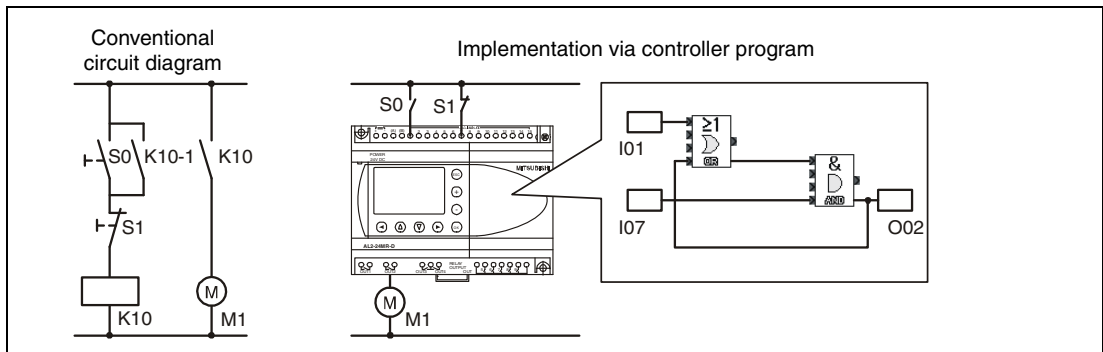

Fig. 5-2: Comparison of circuit diagram and program

5.2 Basic logic functions

When wiring switching elements, basic logic functions that also form the basis of an ALPHA program are implemented. The logic operations below give an overview of the basic functions existing in the ALPHA.

The graphics show, apart from the familiar circuit diagram, the respective function block as it is also shown and programmed in the AL-PCS/WIN-EU software, as well as what is shown on the ALPHA controller display.

By the way, it does not matter if a function block has more inputs than you need. The ALPHA controller "thinks" and considers only the actual circuit in the function.

	Circuit Diagram	Function Block	Display
<p>AND operation: "AND" function block</p> <p>Series connection of make contacts: All switches must be actuated so that the electric circuit is closed.</p>			
<p>OR operation: "OR" function block</p> <p>Parallel connection of make contacts: Activation of one switch is enough to close the electric circuit.</p>			
<p>NAND logic: "NAND" function block</p> <p>Parallel connection of break contacts: To interrupt the electric circuit all switches must be actuated.</p>			
<p>NOR logic: "NOR" function block</p> <p>Series connection of break contacts: If one switch is actuated, the electric circuit is interrupted.</p>			
<p>Exclusive OR operation: "XOR" function block</p> <p>Two-way circuit: Is switched on when one switch is actuated. The additional actuation of the other switch interrupts the electric circuit again.</p>			
<p>Inversion (reversing a signal): "NT" function block</p> <p>Break contact: Upon actuation the electric circuit is interrupted and is closed when the switch is not actuated.</p>			

5.3 Expanded functions

Of course, the ALPHA controller has more to offer than the basic logic operations. You substitute a whole selection of contactors, relays, timers and counters for applicable function blocks that you only need to connect.

A small selection of the most important functions is listed below.

Set/reset: "SR" function block

The output of this function module is closed if the S input is closed and remains closed even after there is no more signal on S. The output of the SR function block is opened again only by a signal on the R input.

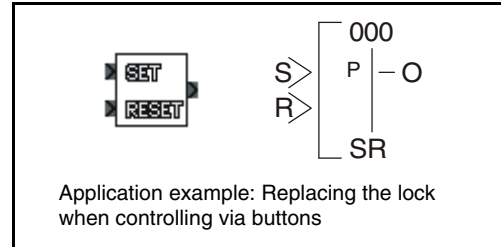

Detecting change in a signal state: "PL" function block

Only when the input signal is switched on is an individual pulse outputted on the output. The function block can also be set so that the output pulse appears when the input is opened.

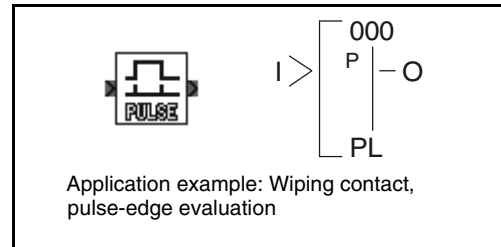

Latch relay: "AL" function block

The output is closed by an input pulse and opened by another input impulse.

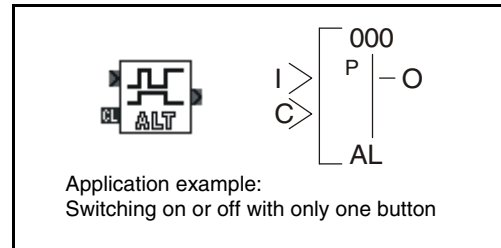

Switching delay: "DL" function block

A closing or release delay can be done selectively with this function block.

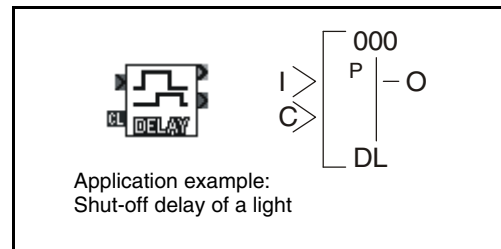

Pulse generator: "OS" function block

After the input signal is switched on the output is closed for a time that you can specify in the range from 0 to 3267 s.

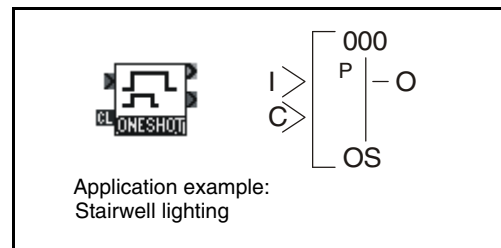

Clock: "FL" function block

Clock with freely selectable make and break times (respectively in the range from 0 to 3267 seconds)

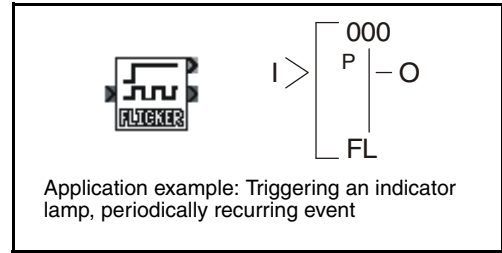

Time switch: "TS" function block

Time switches offer extensive setting options. Apart from switching at a certain time of day and on a certain date, weekly (e.g. always on Mondays and Fridays), monthly (e.g. always on the 12th of each month) or yearly switching (e.g. always on July 15) can also be set.

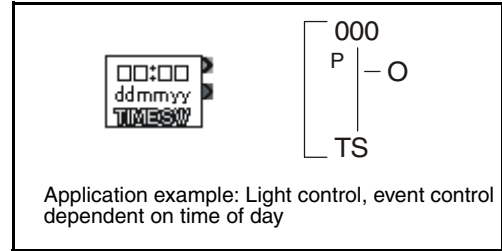

Event counter: "CN" function block

The input pulses are counted. If the preset setpoint (max. 32767) is reached, the output is closed. The counter can be cleared by another input.

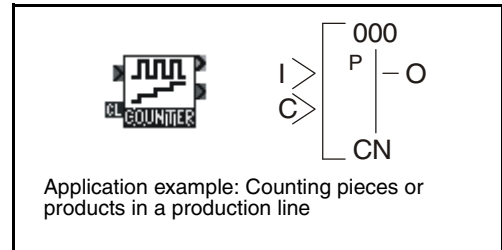

Sending news via SMS: "GSM SMS" function block

A GSM modem connected externally to the ALPHA2 control can send an SMS message to one or more mobile telephone(s) (GSM band) or an e-mail or fax receiver with the help of this function block.

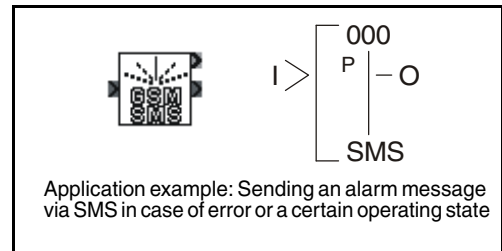

NOTE

Only a small part of the available function blocks can be presented in this beginner's manual. The function blocks shown here therefore represent only an excerpt of the total of 38 function blocks. Please refer to the programming manuals for the ALPHA for detailed information.

5.4 Converting a control task into a program

Conversion made simple

If you already have experience in logic circuitry, you will have absolutely no problems in converting the control task into a program. However, inexperienced users as well will quickly become familiar with the logic of the system.

In many cases a division into individual function blocks already follows from the description of a control task. These function blocks could be those for the following pump control to fill a container.

The start/stop control should be done via buttons. The level is detected by a level switch. The pump is connected directly to a controller output.

If a button is actuated and if the minimum level is not reached, the pump motor is switched on. It runs as long as either the maximum level is reached or the stop button is actuated. (Since buttons are used for the control, a "set/reset" function block must be used). The diagram below shows the design of the process.

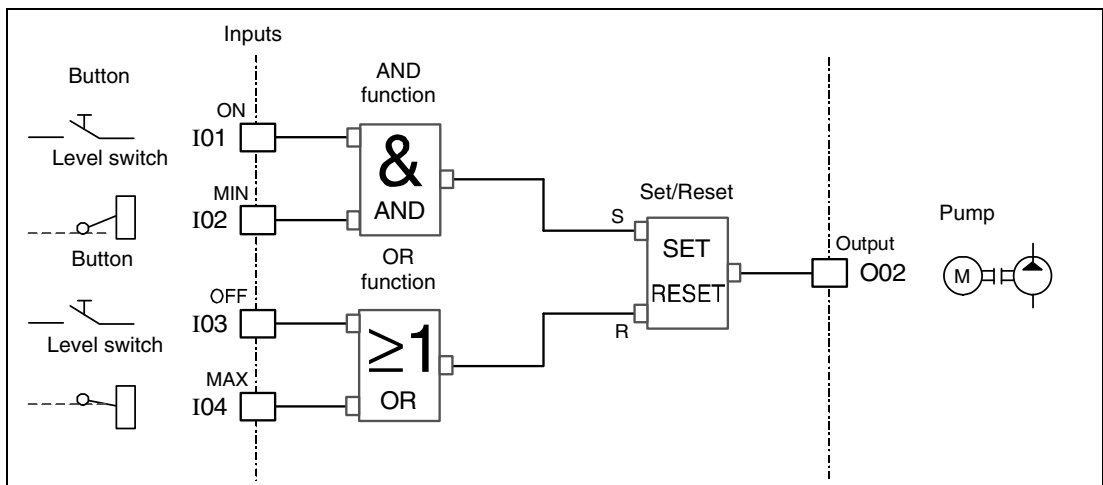

Fig. 5-3: Basic control via function blocks

Program creation

The program example below shows how simple the design can be converted into a program with function blocks.

The function blocks symbolically reflect precisely the function and are simply linked to the inputs and outputs as well as to each other.

The ALPHA programming software AL-PCS/WIN-EU offers the most user-friendly programming possibility via a PC or notebook. Here the necessary function blocks are merged and linked on a graphical interface by drag and drop using the mouse. You therefore need no special programming knowledge.

The other possibility is to input the program via the ALPHA control buttons. Here, too, you make use of graphical symbols that link you on the control display.

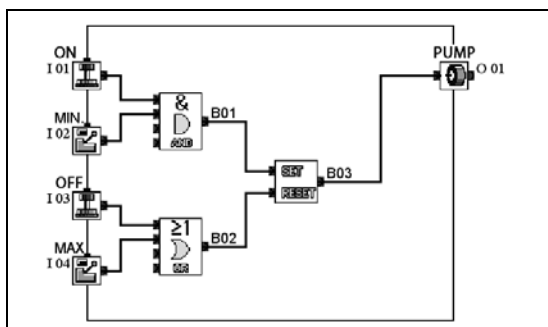

Fig. 5-4: Program creation with AL-PCS/WIN

5.5 Inputting the program

Programming with the ALPHA control buttons

All inputs to create an executable program can be done using the eight buttons of the ALPHA controller.

After being switched on the startup menu appears on the display. The desired function can be quickly and easily selected via the cursor buttons.

The selection or entries are confirmed via the OK button. You can end the entry or a step or jump to a menu level using the ESC button.

In the program creation menu you can then add a function block or a link, increase a value or easily scroll through the menu using the "+" button. You can cancel links, decrease values or scroll back through the menu using the "-" button.

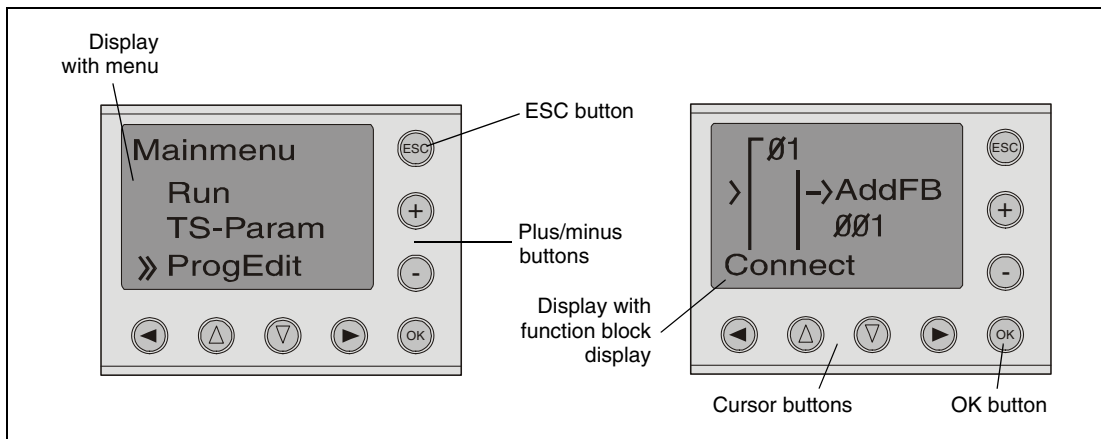

Fig. 5-5: Display representation

Programming with the AL-PCS/WIN-EU software

Programming in conjunction with a PC using the AL-PCS/WIN-EU software can be even more user-friendly than programming via the buttons on the ALPHA.

The graphic display of the function blocks in the software simplifies the programming. The fact that the inputs are shown on the left and outputs on the right side of the screen helps in programming from "left to right". The program can be simulated and the correct function of the program tested before transferring it to the controller even without an ALPHA controller connected.

To transfer the program to the controller, the PC is connected to the ALPHA controller via a separate cable. However, data can also be exchanged via modem.

Once controller and PC are connected, the current program status can also be monitored.

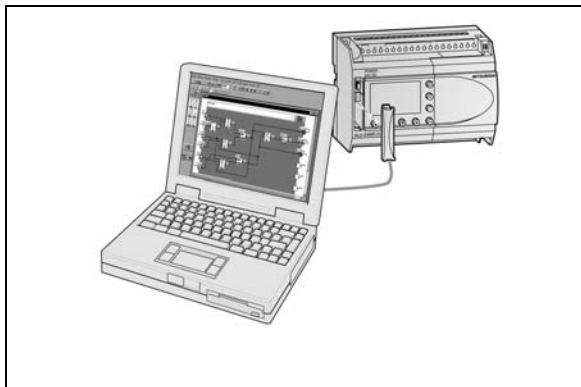

Fig. 5-6: Connection to a PC

6 Programming Examples

NOTE

The circuit diagrams in the examples are for information purposes. They do not consider the particular features of your application. When planning, wiring, installing and starting up an electrical device, be sure to follow applicable provisions and guidelines, especially the VDE regulations.

6.1 Outdoor lighting

An ALPHA2 is used to control the outdoor lighting of a company building. The control task can be quickly and easily solved by combining an external dimmer switch with ALPHA time switches.

The number of circuits is limited only by the available outputs. It is conceivable, for example, to have lights with different switch times for the entrance area, the parking area and the paths to the entrance doors.

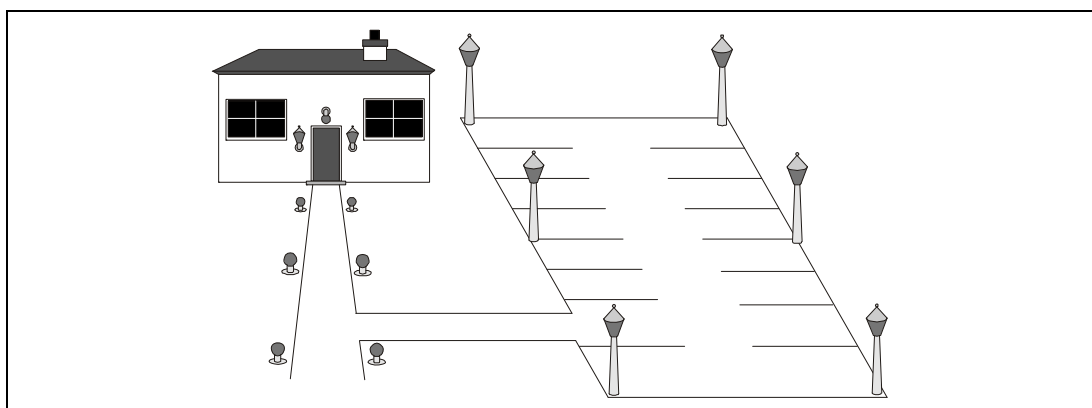

Fig. 6-1: Schematic diagram of outdoor lighting

Description of operation

When dusk sets in the lamps are switched on by a brightness sensor. An ALPHA time switch switches the light off at night and back on again early in the morning (to save energy!). The dimmer switch promptly switches off the outdoor lighting again if it is bright enough.

On weekends when there is no work the outdoor lighting is switched off completely.

The lights can be switched on through a button on the ALPHA control to test the lamps. This permanent connection is switched off at the latest by the control time switch unless it has not been manually switched off earlier through a second actuation of the button.

The ALPHA display indicates:

- the current time of day (summer and winter times are automatically taken into account)
- the switch-off and switch-on time
- the current switching state of the lights (ON or OFF)

The switch times can be quickly and easily changed through the control buttons.

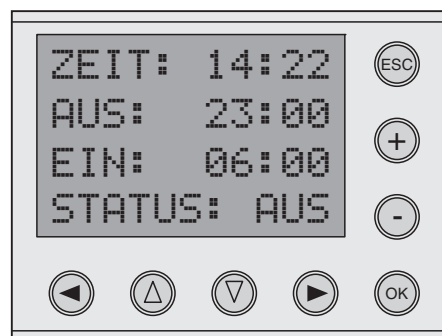

Assignment of inputs/outputs

Function	Address	Label	Assignment
Inputs			
Dimmer switch	I01	S1	When darkness falls I01 is switched on.
Outputs			
Entrance lights	O01	H1	Output switched = light ON
Parking area lights	O02	H2	For extension, output switched = light ON
Path lights	O03	H3	
ALPHA control buttons			
◀ (left cursor)	K8	—	To manually switch lights on and off

Tab. 6-1: Assignment of Inputs/Outputs

Control circuitry

The following diagram shows the circuitry of the existing program example using an ALPHA2 with 230 V voltage supply.

A standard dimmer switch is connected to input 1 (I01) (e.g. Conrad product No. 622206).

The light devices to be controlled are connected directly to the control outputs. However, make sure that the maximum current carrying capacity of the outputs is not exceeded.

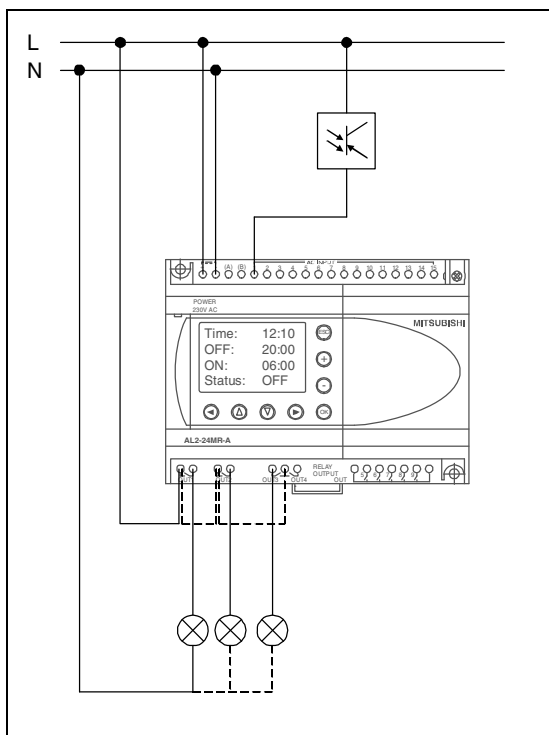

Fig. 6-2: Control circuitry

Expansion options

Beyond the program example presented here, it is also conceivable, for example, to have the additional connection of motion sensors or external light switches.

Apart from the lights other functions such as sprinkler pumps, outdoor advertising, automatic doors, etc. can naturally be managed by the same controller as well.

Program example with the AL-PCS/WIN-EU software

The diagram below shows the associated program programmed by using the AL-PCS/WIN-EU software.

For overview reasons, only the programming for the entrance lights is presented. However, all parts are identical.

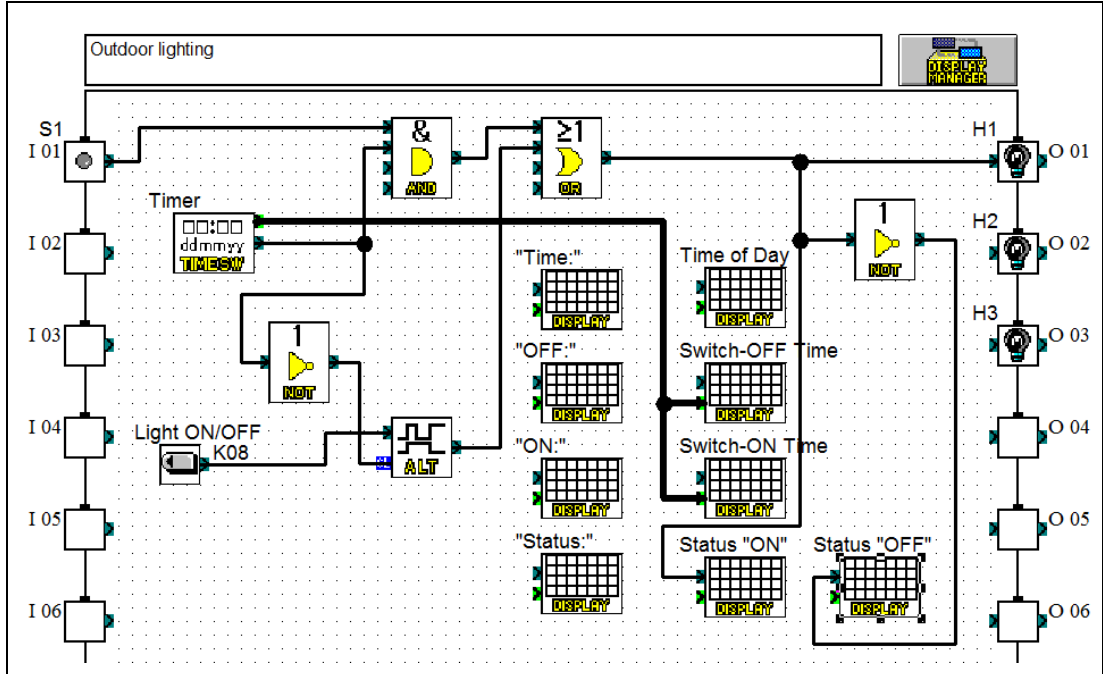

Fig. 6-3: Function block diagram in the software

Description of the program

The lighting can be switched off at night by the time switch through the AND operation of the dimmer switch (S1, I01) and switch clock. The light is on only if the dimmer switch and the output of the clock are closed. For this reason, the switch clock is set so that its output is opened at the time when the lighting should be switched off as well (e.g. around 10 pm OFF and around 6 am ON).

Through the OR function block, which is programmed subsequent to the AND function block, it is ensured that the lighting can be switched either through dimmer switch and clock or through an ALPHA control button.

The ALT function is used to store the button signal. When the button is pressed initially, the output of the ALT function block is closed, and once again opened when pressed the next time. For the switch clock to be able to switch off this output as well, the output signal of the clock is "turned" by the NOT function block and conducted to the clear input of the ALT function. If, for example, the clock output opens around 10 pm, the clear input is closed, thus canceling the manual activation.

The DISPLAY function blocks are used to display the times and switching states. The "ON" and "OFF" texts are shown if the input of the DISPLAY function block is closed. To show that the light is switched off, output O01 is conducted through a NOT function block, thus converting the signal state.

User-friendly setting functions

The AL-PCS/WIN-EU software likewise offers, apart from the programming functions described, a series of user-friendly additional menus with which you can comment on individual function blocks or enter settings and parameters.

Double-clicking with the left mouse button on a function block will open a dialog window where, for example, a commentary can be entered.

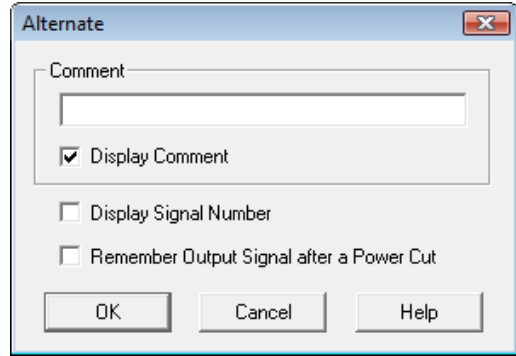

More complex function blocks such as those in this time switch program or the DISPLAY function blocks can be parameterized quickly and clearly through the dialog window.

Enter the switching times for the lights in a table in the "real-time" dialog window.

On the next page you will find how you can subsequently change switch times even without a connected PC.

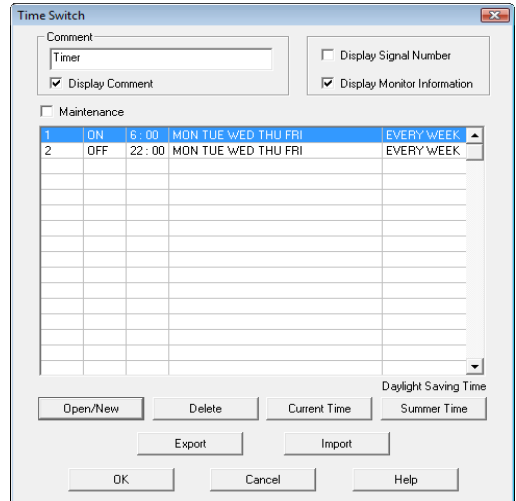

In the Display dialog box you can enter the texts in plain text that should appear on the display under the given conditions.

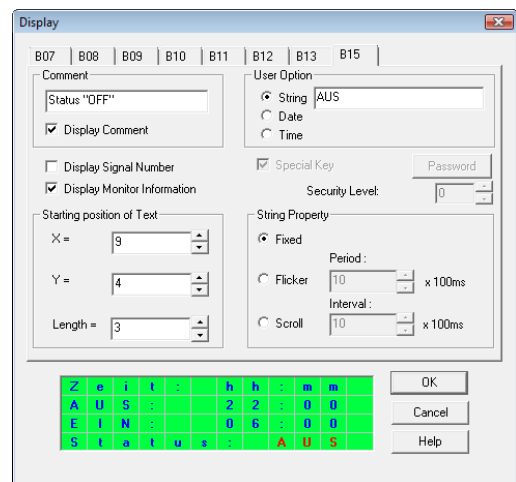

Changing switching times on the ALPHA controller

The switching times can be changed quickly during operation using the control buttons.

With the ▲ or ▼ cursor buttons choose the time which you wish to change.

The chosen time flashes.

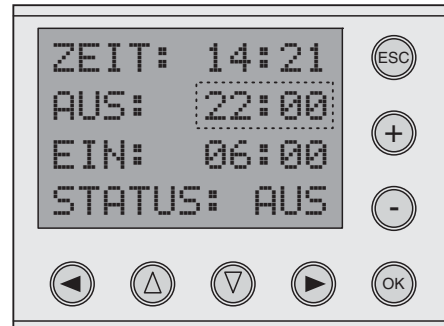

Pressing the OK button will show the settings of the time switch.

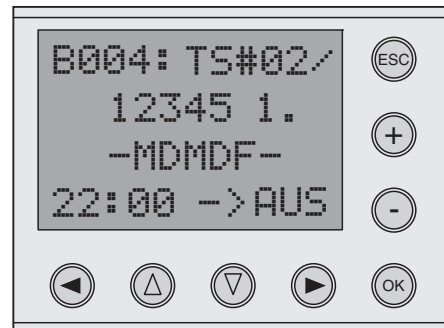

With the ▲, ▼, ◀ and ▶ buttons place the cursor on the setting that should be adjusted.

Then with the "+" or "-" button choose the new value.

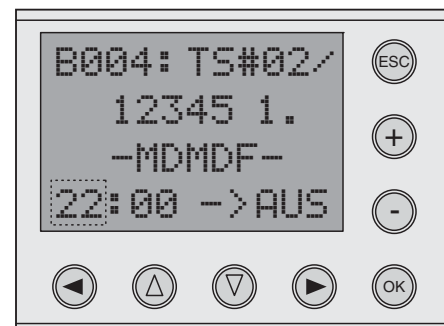

After pressing the OK button the controller will adopt the new settings.

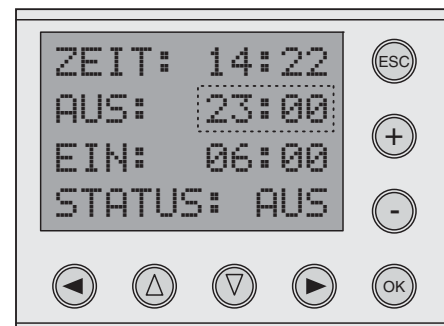

With this example it becomes evident how simple subsequent changes are possible even without a PC.

6.2 Stairwell light

The control for floor or stairwell light is a classic case of application for the ALPHA.

In this example the lighting of building floors and stairwells are controlled via switches and the integrated time switch function block of the ALPHA.

Deactivation happens automatically by means of switching delay if the light was not manually switched off. At night the light can also be switched on automatically by means of the time switch function.

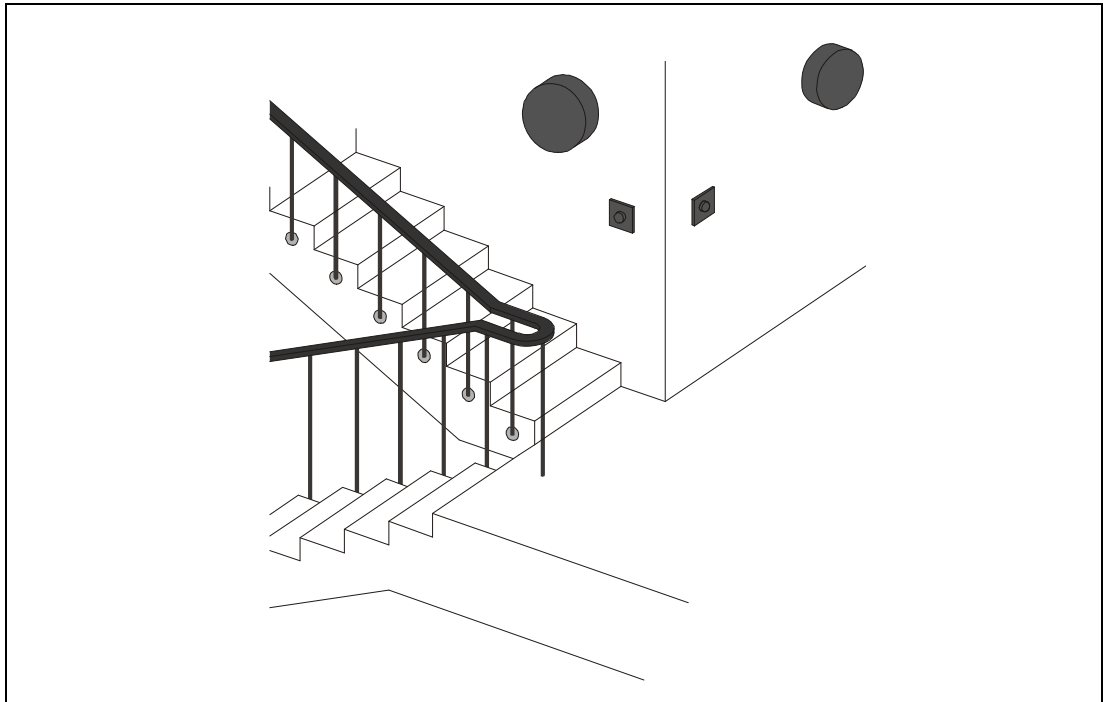

Fig. 6-4: Schematic diagram of a stairwell light

Description of operation

Pressing the button (S1, S2 or S3) will switch the light ON and OFF.

The light, for example, can be switched on via S1 and then switched off via S3. This function is also obtained via one and the same switch.

If DURATION switch S4 is not switched on, the lighting is automatically switched off again after 6 minutes after the light was switched on via buttons S1 to S3. However, the light can also be switched off manually and early via buttons S1 to S3.

If DURATION switch S4 is switched on, automatic switch-off is deactivated. The light can then be switched off manually only via buttons S1 to S3.

The lighting is switched on daily from 6 pm to 10 pm. During this time actuation of switches S1 to S3 will have no effect.

Assignment of inputs/outputs

Function	Address	Label	Assignment
Inputs			
Stairwell button 1	I01	S1	The input is closed when the button is pressed.
Stairwell button 2	I02	S2	
Stairwell button 3	I03	S3	
Continuous light	I04	S4	Switch
Outputs			
Lighting	O01	H1	Output switched = light ON

Tab. 6-2: Assignment of Inputs/Outputs

Control circuitry

The following diagram shows the circuit of the existing program example using an ALPHA with 230 V voltage supply.

The buttons for switching on and off are connected to inputs 1 to 3 (I01 to I03). The switch for the continuous light are connected to input I04.

The light devices to be controlled are connected directly to the control outputs. However, make sure that the maximum current carrying capacity of the outputs is not exceeded.

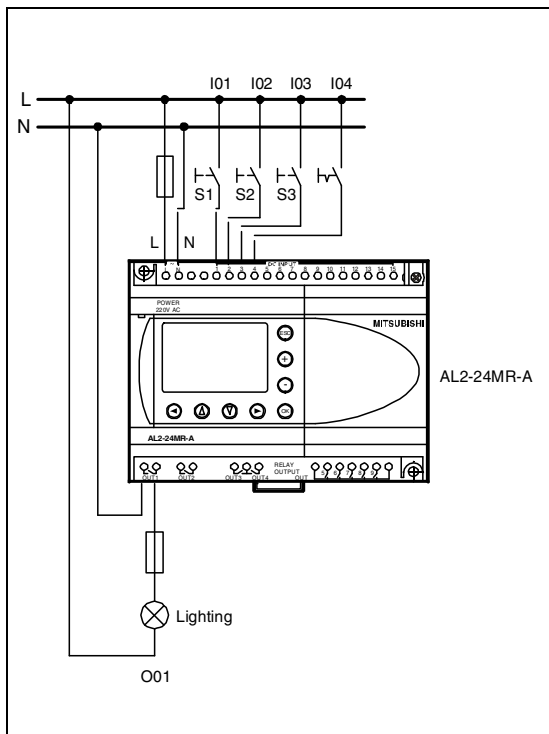

Fig. 6-5: Control circuitry

Expansion options

Instead of buttons, for example, motion detectors can be connected as well. A light sensor can be connected for brightness-dependent control.

Floor-dependent stairwell lighting is also conceivable.

Program example with the AL-PCS/WIN-EU software

The diagram below shows the associated program programmed by using the AL-PCS/WIN-EU software.

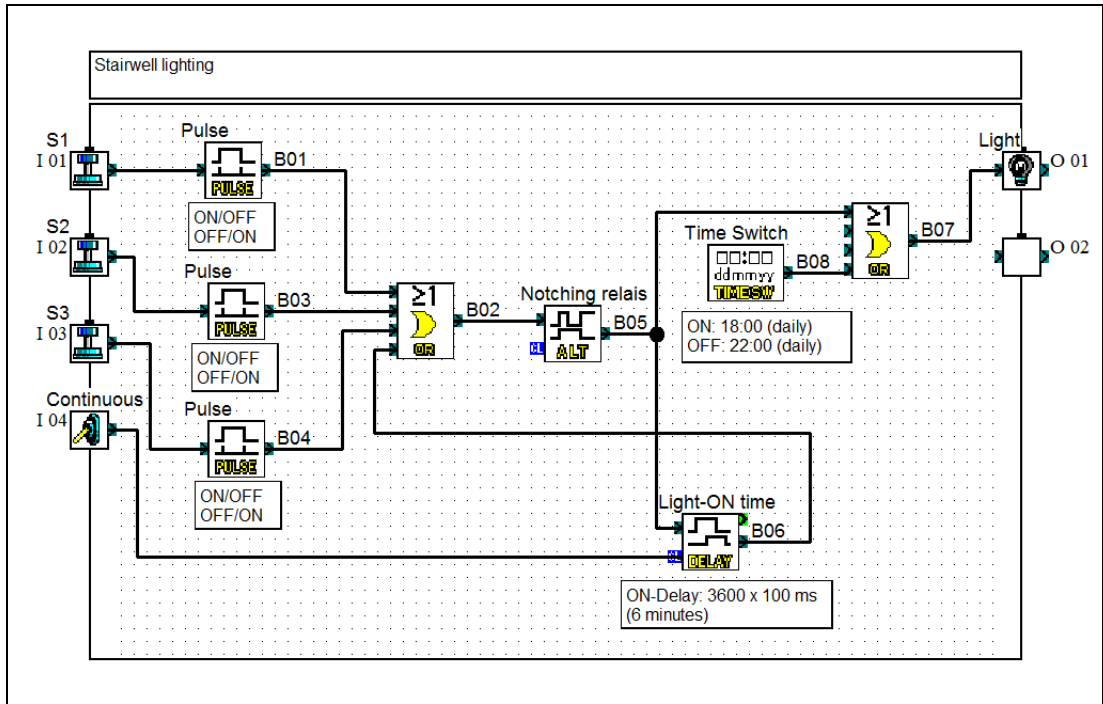

Fig. 6-6: Function block diagram in the software

Description of the program

When buttons S1, S2 and S3 are pressed, a pulse is generated which reverses the output of the ALT function block and thus output O01 as well. This ensures the manual switching of the lights.

At the same time, with output O01 the closing delay (DELAY function block) is activated by the latch relay and the time starts to run. If the light was switched off in the meantime with a button, the input of the ALT function block is closed via OR operation after the set time elapses. The output state of the latch relay changes and the light is switched off. Switching of the closing delay works in the same manner as actuation of buttons S1, S2 and S3.

The DELAY function block on input I04 is locked through switch S4, preventing automatic deactivation. The light is lit continuously. But buttons S1, S2 or S3 continue to be operative and can be used to switch off the light.

The OR function block in front of output O01 ensures that the lighting can be controlled by the latching relay or by the time switch. The time switch carries out the automatic activation of the lights.

6.3 Roller shutter control

The roller shutters of a residential house can be easily controlled using conventional roller shutter drives and an ALPHA control. Apart from manual control, an automatic operation with brightness-controlled lowering and time-controlled raising of roller shutters is also available.

In this example the control of a window roller shutter and a patio roller shutter is demonstrated. The program is expandable to other drives depending on the requirement.

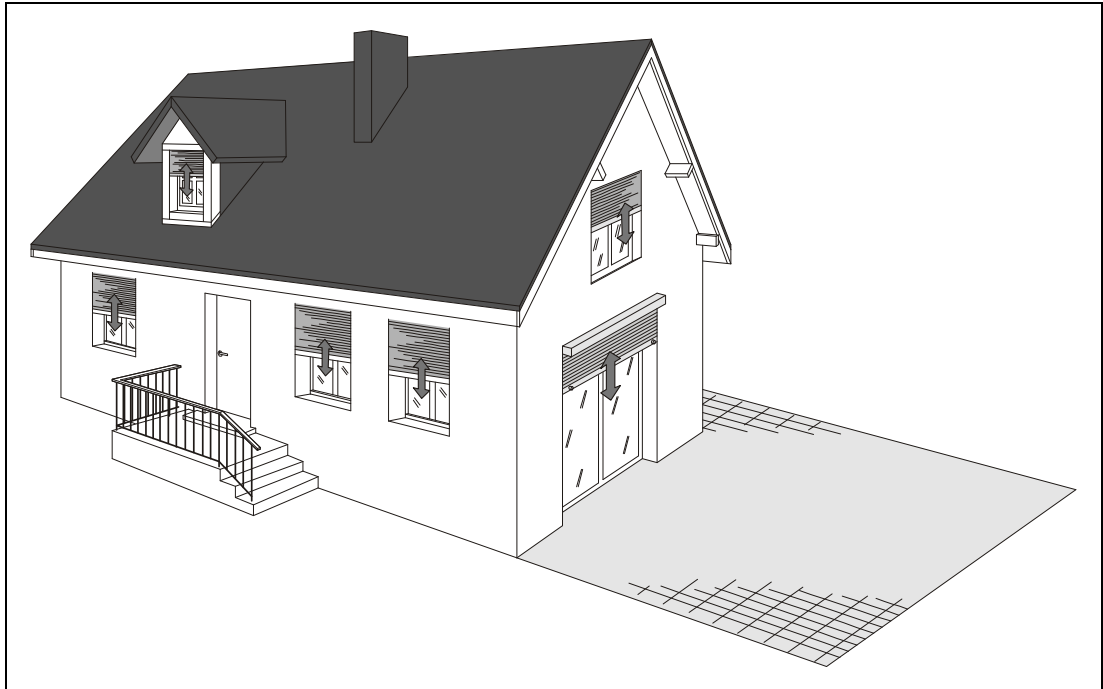

Fig. 6-7: Schematic diagram of a roller shutter control

Description of operation

The switch clock allows the dimmer switch to lower the roller shutters starting from 5 pm when it gets dark. The output signal to lower can remain switched on. The roller shutter drives have internal limit switches.

On weekdays the roller shutters are opened around 8 am, on the weekend only around 9 am.

The position of the roller shutters can be affected manually via two buttons on each drive. No additional change-over switch is needed in windows to select manual or automatic mode! If a button is pressed longer than 2 seconds, the roller shutter goes in the corresponding direction. The other button is pressed briefly to stop. At the next automatic switching the manually adjusted roller shutters are "carried along" and go to the preset end position.

Roller shutters for the patio door have a special feature. In order, for example, to prevent the roller shutter from automatically lowering on a summer night while people are on the patio, another switch is installed for this purpose. Only when this switch is actuated will the roller shutter close automatically. This switch can be designed as door contact: only after people have left the patio and the door is closed will the roller shutter go down automatically.

Assignment of inputs/outputs

Function	Address	Label	Assignment
Inputs			
Dimmer switch	I01	S1	When it gets dark I01 is closed.
Window roller shutter OPEN	I02	S2	Button; the input is closed when pressed.
Window roller shutter CLOSED	I03	S3	
Patio roller shutter AUTO	I04	S4	When the switch is actuated and when darkness falls the roller shutter is automatically closed.
Patio roller shutter OPEN	I05	S5	
Patio roller shutter CLOSED	I06	S6	Button; the input is closed when pressed.
Outputs			
Open window roller shutter	O01	K1	When an output is switched on, the roller shutter moves to the corresponding direction. The outputs can remain switched on continuously since the drives automatically turn off through internal limit switches.
Close window roller shutter	O02	K2	
Open patio roller shutter	O03	K3	
Close patio roller shutter	O04	K4	

Tab. 6-3: Assignment of Inputs/Outputs

Control circuitry

In the diagram below a conventional dimmer switch is connected to input 1 (I01) of an ALPHA with 230 V voltage supply. The buttons for manual control are linked to other inputs.

The roller shutter motors to be controlled (conventional tube motors with limit stop) are connected directly to the control outputs.

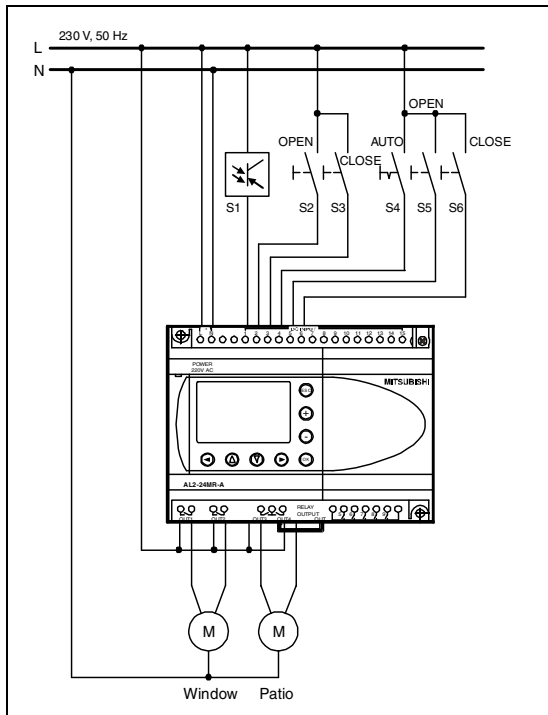

Fig. 6-8: Control circuitry of the roller shutter control

Expansion options

A sunlight sensor (an additional input), for example, can protect plants from strong sunlight or prevent the room from heating up. In order not to plunge the room in total darkness, the roller shutters in this case are not completely closed but are lowered only for a certain time.

Program example with the AL-PCS/WIN-EU software

The diagram below shows the associated program programmed by using the AL-PCS/WIN-EU software.

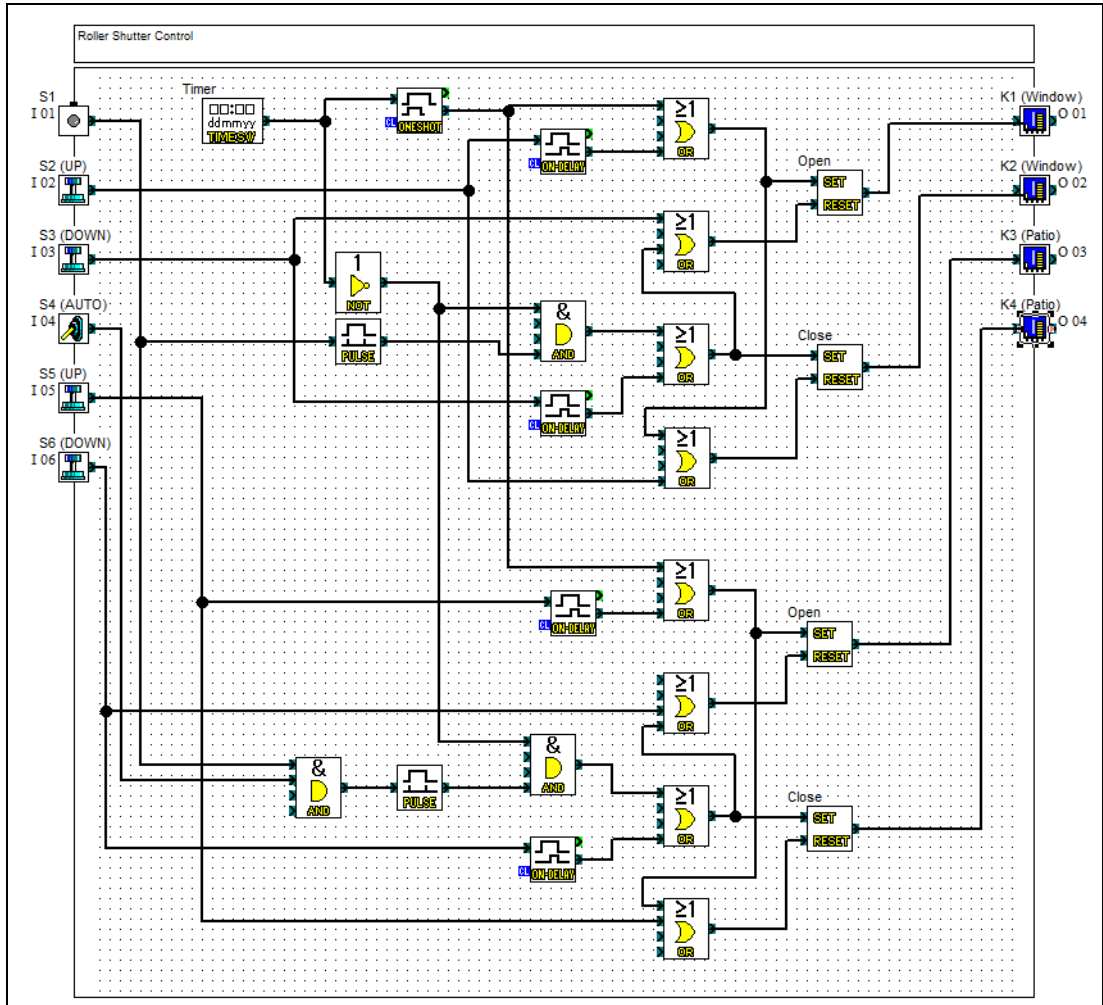

Fig. 6-9: Function block diagram in the software

Function Block	Parameterization	Remark
TIMESW	Monday to Friday: 7 am ON Saturday & Sunday: 9 am ON Daily: 5 pm OFF	The times can be adjusted to the individual conditions (e. g. vacation).
ONESHOT	Pulse length 1 second	When the output of the switch clock is closed, one pulse is generated to open the rollers.
PULSE	Evaluation of rising edge	Pulse to close the roller shutters
ONDELAY	Closing delay of 2 s	When a button is pressed, the roller shutter drive is switched on after the closing delay elapses.

Tab. 6-4: Description of special function blocks

Description of the program

Since the switching is done using buttons and brief pulses have to be cached, S/R function blocks are used. The OR function blocks placed before the SET and RESET inputs cause the setting and resetting of outputs through different signal sources. The S/R function blocks for opening the roller shutters are set by the switch clock or the buttons. However, the clock signal must not be switched on all the time because then lowering the roller shutters by hand would no longer be possible. For this reason, a brief pulse is generated by the ONESHOT function block when the clock is switched on and this pulse causes the roller shutter to go up.

The buttons for manual control act on a set input through closing delays (ONDELAY) and directly on a reset input. Briefly pressing the buttons will stop the roller shutters and only when pressed longer they will move to the corresponding direction.

A reset input, for instance, to close the roller shutters, is closed respectively by the set input of the other function (in this example: "open"). This prevents both outputs from being closed simultaneously.

To lower the roller shutters when it gets dark, the switch clock output is inverted by the NOT function block and conducted to two AND operations. The input of the AND function blocks are closed with an open clock output. Now when the dimmer switch switches, the roller shutters are lowered. Since the PULSE function blocks detect only the closing of the dimmer switch, the roller shutters, if necessary, can be opened manually even when it is dark.

The signal of dimmer switch S1 is merged with switch S4 through an AND function block for the roller of the patio door. If switch S4 is actuated ("Auto" position) the roller lowers with the other roller shutters when it gets dark. However, if S4 is opened when darkness falls, the patio roller shutter lowers only if the switch is actuated.

6.4 Control of conveyor belts

In this application the ALPHA controls three conveyor belts at the outlet of a production facility (for instance, coating of chip boards used to make furniture). The machine places the product on the first conveyor belt. The quality of the plate is checked and rejects removed on the second conveyor belt. The third conveyor belt serves as approval area for qualitatively perfect products.

The program can easily be expanded to control more than three conveyor belts by copying the program section for controlling the middle belt and equipping it with the corresponding input and output signals.

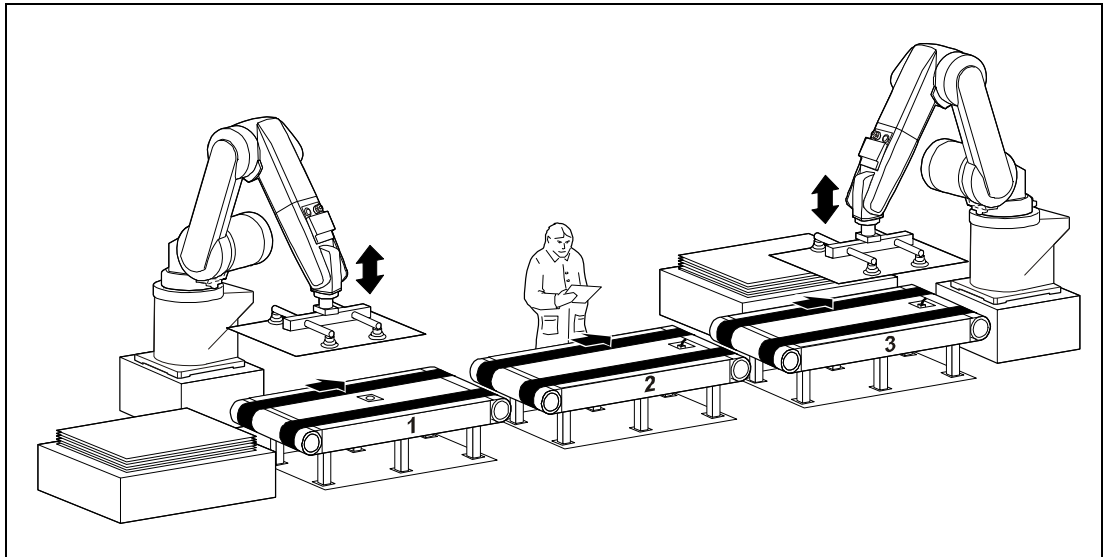

Fig. 6-10: Outlet of a production system with conveyor belts

Description of operation

The machine places the finished product on conveyor belt 1. If conveyor belt 2 is free, the product is brought from belt 1 to belt 2 and the next product can now be placed on belt 1.

The product undergoes a quality check on belt 2. For this reason, it stops here for a time that can be set in the ALPHA controller. If the quality is poor the wooden plate is removed from the belt. If the quality meets requirements, the plate is automatically brought from belt 2 to belt 3 after the testing period elapses. However, the operator can also interrupt the waiting time by pressing a button and cause the plate to go further immediately.

The plates are then removed from belt 3. In the event of a jam the products always move up to the next free belt. This also happens if belt 3 is still occupied, a product of poor quality is removed from belt 2 and a new product has already been placed on belt 1.

Assignment of inputs/outputs

Function	Address	Label	Assignment
Inputs			
Belt 1 occupied	I01	S1	Proximity switch (input closed = belt occupied)
Belt 2 occupied	I02	S2	Mechanical limit switch (input closed = belt occupied)
Belt 3 occupied	I03	S3	
Bring product to belt 3	I04	S4	Manually operated button
Outputs			
Switch on belt 1	O01	K1	(output closed = belt running)
Switch on belt 2	O02	K2	
Switch on belt 3	O03	K3	
Release to production system	O05	—	Output closed = product can be placed on belt 1

Control circuitry

For practical implementation of a control task an ALPHA controller is used with 24 V DC voltage supply. Likewise for safety reasons 24 V DC supply has become the quasi-standard in industry for sensors and contactors to drive motors.

The motors to be controlled are driven via contactors connected to the control outputs. The release signal for the production system can be switched directly through the relay outputs of ALPHA and the associated electrical isolation.

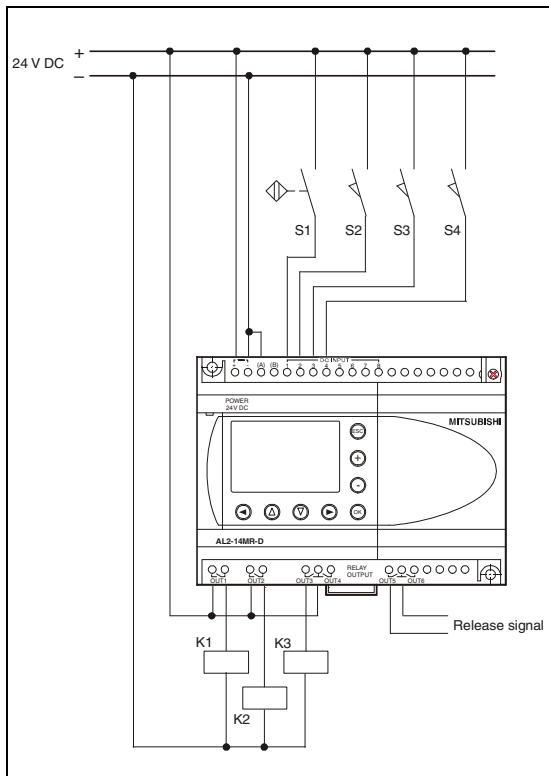

Fig. 6-11:
Control circuitry for controlling conveyor belts

Expansion options

As already mentioned above, the program can be easily expanded for other conveyor belts or modified for similar applications.

In order not to make this example too complicated, manual belt control was deliberately left out. However, a retrofit should not pose any problems for you.

Moreover, for practical applications it must be taken into account that there is no product between the Occupied switches (for instance, in case of voltage loss), the control therefore does not recognize this and this could lead to collisions when the system is started. A possible solution would be to let the unoccupied belts run for a certain time after the system is switched on. If there is a product somewhere, the Occupied switch is actuated and the belt stopped. If no product was lying around, the belt is stopped after some time and is now ready for further operation.

Program example with the AL-PCS/WIN-EU software

The diagram below shows the associated program programmed by using the AL-PCS/WIN-EU software.

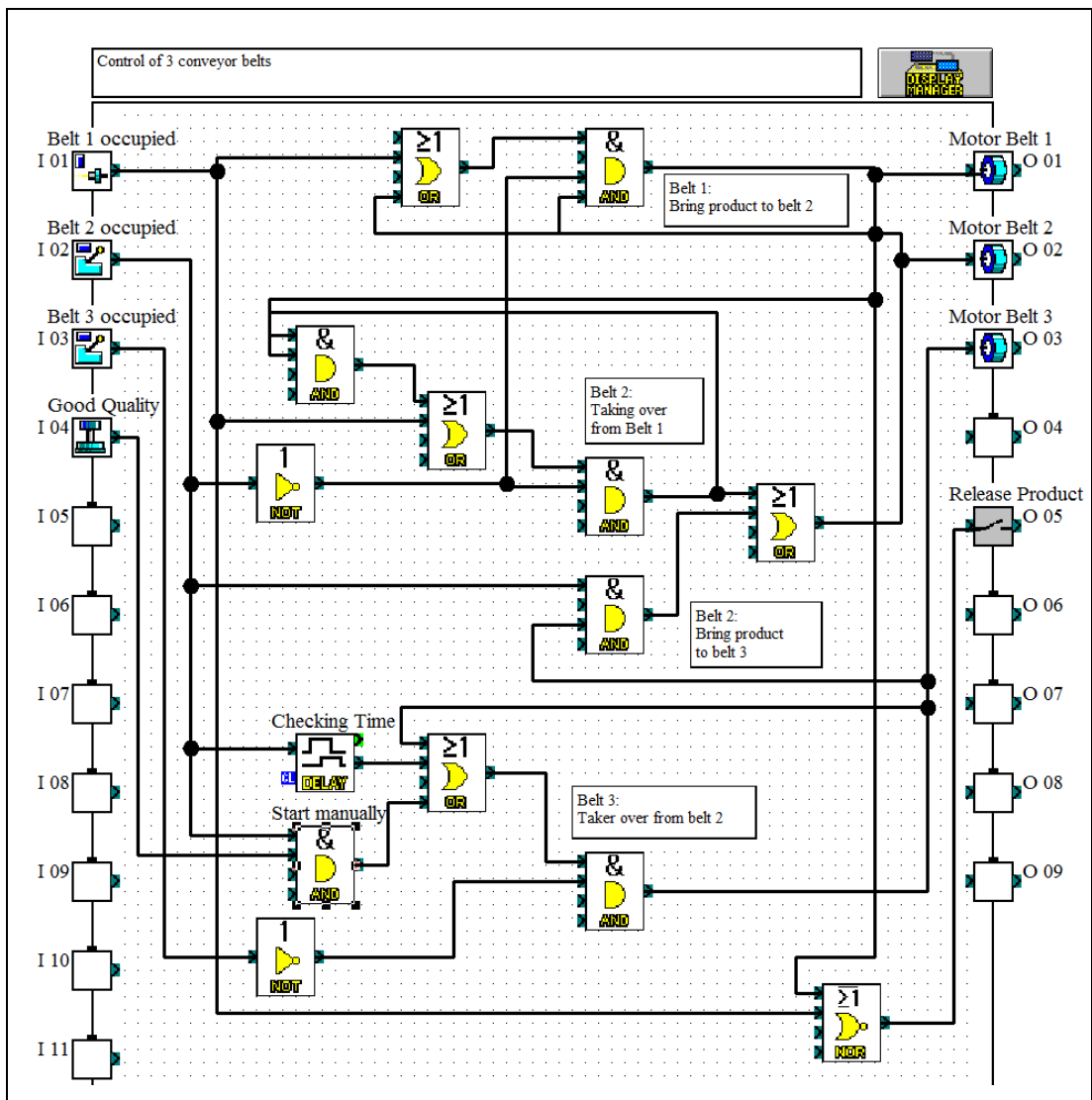

Fig. 6-12: Program for controlling conveyor belts

Description of the program

The conditions required in the description of operation above are realized using the basic logic functions AND, OR, NOR and NOT.

In conveyor belts the following belt should always be switched on first so that the material to be conveyed is not pushed towards a stationary belt.

If belt 1 is occupied and belt 2 is free, belt 2 is switched on. This will also start belt 1 and transfer the product to belt 2. Since the product occupies both belts temporarily and none of the switches, the drives must remain switched on even in these cases. This is reached using an OR operation with the machine's own output signal (lock).

Once the product reaches switch S2 (I02), belt 1 and belt 2 are stopped. If belt 1 is standing and is not occupied, output O04 is closed and the release is given for placing a new plate.

The test period starts once belt 2 is occupied or stopped. During this time the product remains on belt 2 so that quality can be examined. After this time elapses or after the button is pressed (I04), belt 3 is started provided it is free. This also starts belt 2. A lock again ensures that the belts remain switched on until S3 (I03) is reached.

6.5 Ventilation of an underground garage

Good ventilation or the removal by suction of exhaust gases is important in underground garages so that the concentration of toxic carbon monoxide (CO) in the garage does not reach dangerous levels.

A ventilator that is operated at all times at a constant (high) speed entails high operating costs. One way to save energy is to use a frequency inverter that converts the fixed voltage and frequency of the power grid to variable voltages and frequencies. This allows a simple three-phase induction motor to be operated at variable speed.

Power consumption in fans and ventilators does not increase in a linear fashion with speed but quadruples. This means that even small speed reductions can lead to large energy savings. The extra expenses for the frequency inverter are soon balanced out through the savings in operating costs.

In addition, a frequency inverter has other advantages such as adjustable acceleration and delay times, torque boosting, integrated electronic overcurrent protection, etc.

In combination with an ALPHA and a carbon monoxide measuring device, the ventilation can be controlled as needed.

Please refer to the company website (www.mitsubishi-automation.de) for more information about Mitsubishi Electric frequency inverters.

Description of operation

A measuring module whose analog output from 0 to 10 V is connected directly to the ALPHA is used to measure the carbon monoxide concentration in the underground garage. Depending on the level of carbon monoxide concentration in the air, various control signals are switched on to preselect the speed in the FR-D700 frequency inverter.

A fault in the frequency inverter is flagged by a flashing indicator lamp in the same manner as excessive carbon monoxide concentration in the air. In addition, in case of a persistently high CO concentration, a text message is sent through a GSM modem to, say, warn the operator of the underground garage.

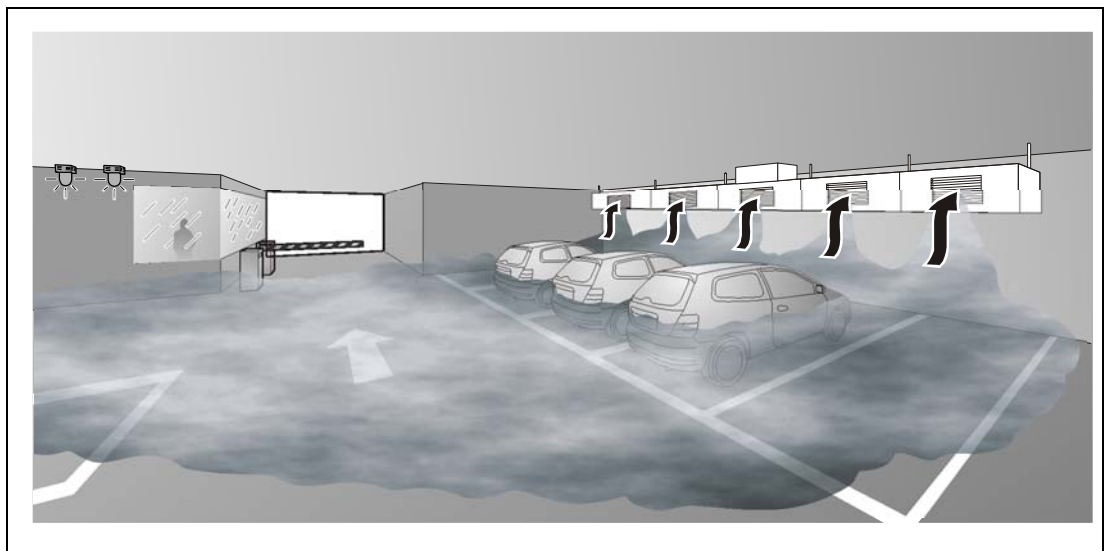

Fig. 6-13: Ventilation of an underground garage with frequency inverter and ALPHA controller

Assignment of inputs/outputs

Function	Address	Label	Assignment	
Inputs				
Frequency inverter fault	I01	A/C	Alarm output of the frequency inverter	
Ventilation OFF	I02	S0	Button (break contact); the input is opened when pressed.	
Ventilation ON	I03	S1	Button (make contact); the input is closed when pressed.	
Carbon monoxide measuring device	I04	E1	Measuring module with analog output (0 to 10 V)	
Outputs				
Frequency converter fault	O01	H1	Indicator lamp, flashes if there is a fault in the frequency converter	
CO alarm	O02	H2	Indicator lamp, flashes if the carbon monoxide concentration is too high	
Frequency converter start	O05	STF	Start signal for frequency inverter	
Speed 1	O06	RL	Speed preselection for frequency inverter	Slow speed
Speed 2	O07	RM		Intermediate speed
Speed 3	O08	RH		High speed

Description of the circuit diagram

Analog inputs are available only in basic ALPHA devices with 24 V DC voltage supply. Therefore, an AL2-24MR-D type controller is used for this example. The modem needed to send a text message is not shown in the following circuit diagram.

The frequency inverter activates a relay with a changeover contact in case of an alarm (terminals A, B and C). In this case, the make contact uses A/C (fault -> contact closed -> input I01 closed).

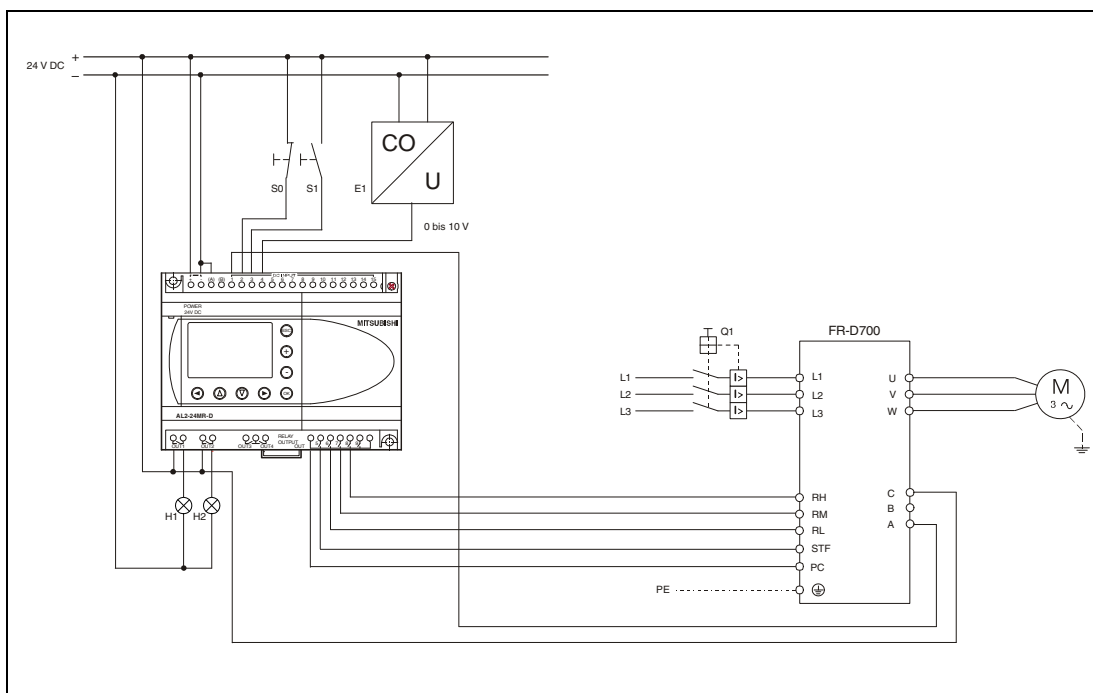

Fig. 6-14: Controlling a frequency inverter using an ALPHA controller

Operational reliability must also be ensured if transmission of signals from the switches to the PLC is interrupted. For this reason, a button with make contact is used to switch on ventilation and a button with break contact to switch it off.

On the PC terminal of the inverter is a 24 V DC voltage with which the control signals can be switched via the output contacts of the ALPHA. The speeds or frequencies which the frequency inverter outputs when the RL, RM and RH signals are switched on are stored in the inverter and can be easily changed by the user.

Expansion options

Using the three RL, RM and RH control signals up to 7 speeds/frequencies can be requested by simultaneously switching on two or three signals. This can be done easily using the basic logic operations. In this manner the drive motor power can be better adapted to the power requirement.

Program example with the AL-PCS/WIN-EU software

The following diagram shows the program inputted using the AL-PCS/WIN-EU software for this example.

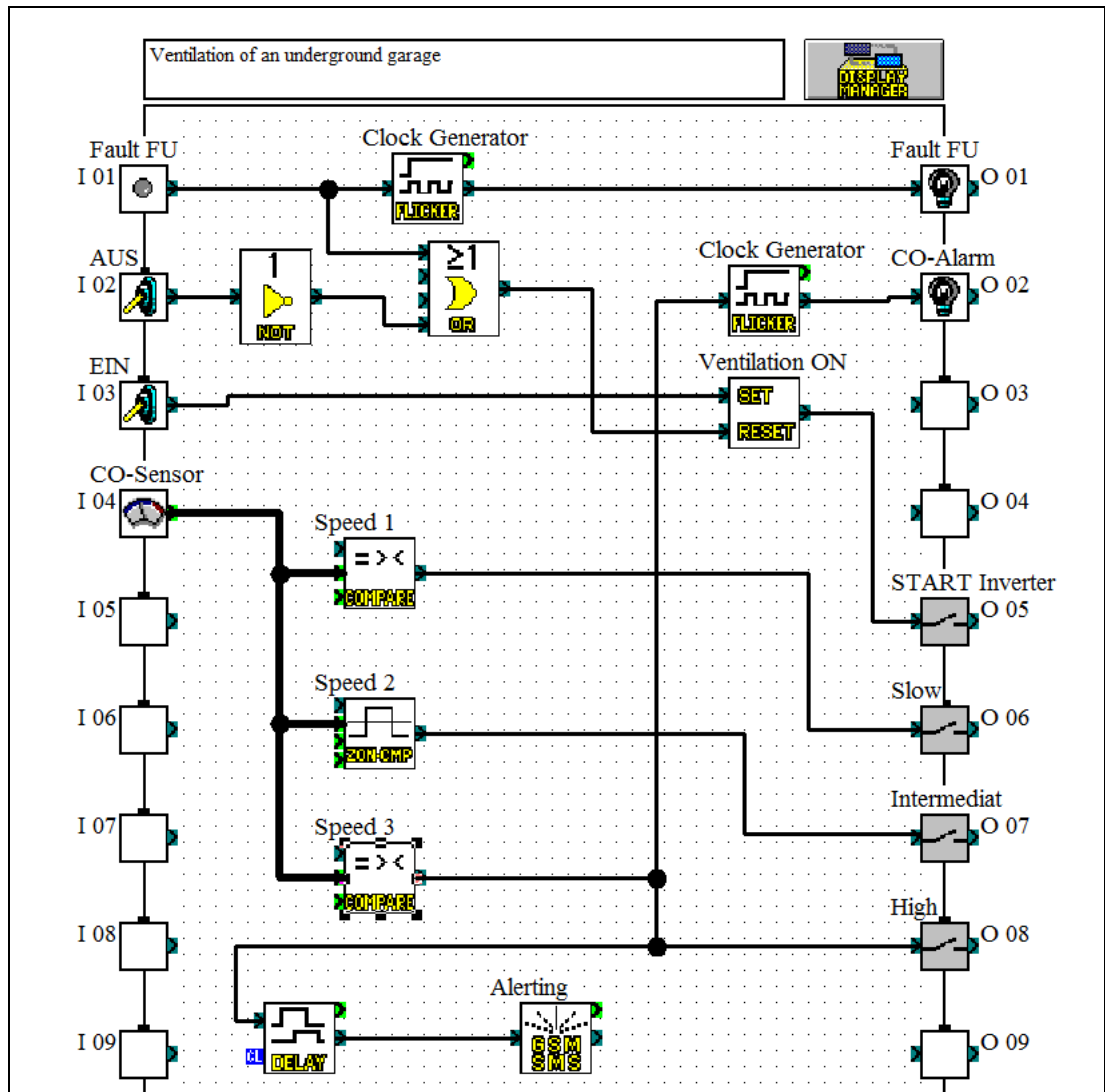

Fig. 6-15: Program for controlling a frequency inverter

Description of the program

The above-mentioned operational reliability is also considered during programming. In the program the make contact of the ON button acts directly on the set input of the SR function block. The signal from the break contact of the OFF button is inverted and then acts on the reset input of the SR function block. This switches off the output and hence the frequency inverter if input I02 has the "0" signal state. This is the case when the OFF button is pressed or if the connection between the button and input I02 is broken. This switches off the drive or prevents activation even when there is wire breakage.

In case of fault in the frequency inverter, the start signal is likewise switched off and an indicator lamp activated (H1 on output O01). Because a flashing light is better perceived, an FL function block is used to generate a cycle.

Input I04 is used as analog input. The measurement output of the carbon monoxide measuring device is connected here. The input voltage of 0 to 10 V is a measure of carbon monoxide concentration in the air and is converted in the ALPHA into values of 0 to 500.

To select the three fan speeds, two limit values for CO concentration are established during programming and these values are later monitored by the program during operation.

A CP function block is used to detect the first limit value. This block compares this limit value to the value of the analog signal. "Less than" (<) is used here as comparison requirement. This means that output O06 (slow speed) is always closed if the analog value is less than the first limit value.

The fan can run at the intermediate speed if the value of the analog signal is between the first and second limit value or is equal to one of these values. This requirement can be met very easily using a ZC function block (range comparison).

Another CP function block monitors whether the second limit value is exceeded. This time "greater than" (>) is used as comparison requirement to close output O08 in this case. In addition, a flashing indicator lamp will signify that the limit value has been exceeded. A separate FL function block is used here so that a flash frequency can be used other than the one for the H1 lamp. This simplifies the identification of faults.

If the second limit value is exceeded for a longer period, a text message is sent to the GSM SMS function block via the closing delay.

7 Expansion Options

7.1 Expansion modules and memory cassettes

Digital expansion modules

Do you need additional inputs or outputs?

There are various expansion modules available for the ALPHA2. These modules will add additional inputs or outputs to the controller. The modules are inserted directly into the ALPHA2 and therefore do not occupy any additional space.

The AL2-4EX also offers the possibility of using two inputs as quick counters with a counting frequency of 1 kHz.

Other expansion modules such as analog outputs or temperature converters are currently under development and will be available shortly. The ALPHA is therefore the right concept even for future applications.

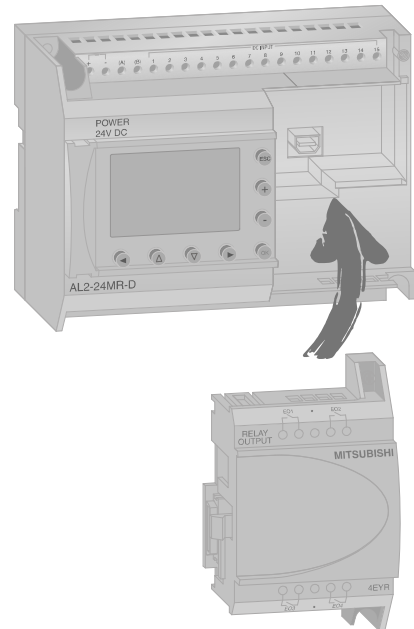

Type	Number of Inputs	Number of Outputs	Input/Output Voltage	Output Type	Max. Switching Capacity
AL2-4EX-A2	4	—	220–240 V AC	—	—
AL2-4EX	4	—	24 V DC	—	—
AL2-4EYR	—	4	100–240 V AC	Relay	2 A per output (250 V AC / 30 V DC)
AL2-4EYT	—	4	24 V DC	Transistor	1 A per output (24 V DC)

Analog expansion modules

The analog expansion modules expand the range of application of the ALPHA 2 by a multiple. Voltage or current values can be outputted or temperature values recorded using these modules.

In total there are 3 different analog expansion modules available.

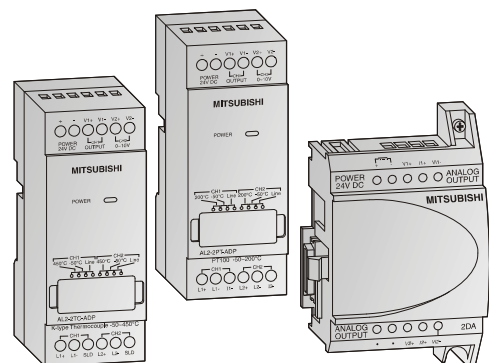

Type	Number of Inputs	Number of Outputs	Input Signal	Output Signal
AL2-2DA	—	2	—	0 to 10 V DC/4 to 20 mA
AL2-2PT-ADP	2	—	Temperature (Pt100)	—
AL2-2TC-ADP	2	—	Temperature (thermocouples type K)	—

Voltage supply

For the voltage supply of 24 V devices or other external electric loads ALPHA POWER power units are available in installation distributors. They go with the ALPHA family in terms of measurements and are designed for wall or DIN rail assembly.

Up to five power units can be switched parallel to boost power or for redundancy reasons. The power units have adjustable output voltage, thermal overload protection and a power LED.

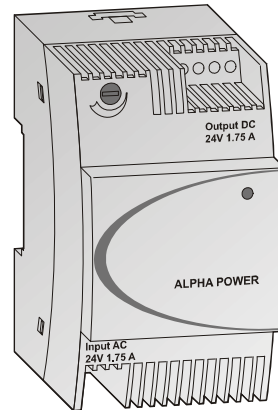

Type	Input Voltage	Output Voltage	Output Current
ALPHA POWER 24-0.75	100–240 V AC	24 V DC	0.75 A
ALPHA POWER 24-1.75	100–240 V AC	24 V DC	1.75 A
ALPHA POWER 24-2.5	100–240 V AC	24 V DC	2.5 A

Memory cassettes

With an AL2-EEPROM2 memory cassette a new program can be transferred to the internal memory of the ALPHA control or the program from the internal memory secured in the external memory cassette.

The use of the memory cassette has the advantage that a special program can be run simply by plugging in the external memory module. After the memory cassette is removed the old program in the internal memory becomes active again.

AL2-EEPROM2 memory cassettes are not memory expansions but a data exchange medium.

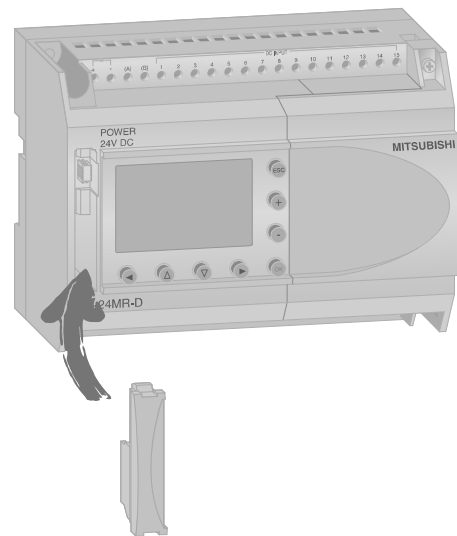

7.2 Communication options

PC, modem and cellular telephone connection

The AL-232CAB interface cable is available to connect the ALPHA controller to a personal computer or notebook where the program software for the ALPHA modules is located.

The cable is plugged simply into the controller on one side and into a free serial interface of the PC on the other.

For important monitoring functions the ALPHA offers the possibility of sending SMS data to a GSM modem to be forwarded to cellular telephones, e-mail addresses or fax machines. To this end the AL2-GSM-CAB GSM cable is available to connect the ALPHA2 control to a normal or a GSM modem, a PC or other peripheral components.

Remote monitoring and remote maintenance are also possible.

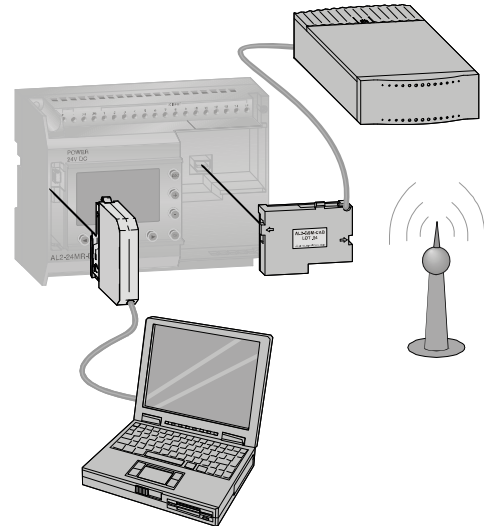

Connection to a network

ALPHA controllers can be integrated into an actuator-sensor-interface network as slave modules. The AL2-ASI-BD is needed for data communication via the AS interface system. Up to 4 inputs and 4 outputs can be exchanged with the ASI master.

The address assignment of slave devices in the AS interface is done either automatically via the master in the network or via a programming device (software).

The maximum transmission distance is 100 m without repeater. If two repeaters are used the transmission distance can be 300 m.

A separate voltage supply is required for the AS interface. The communication signal is superimposed on the AS interface bus.

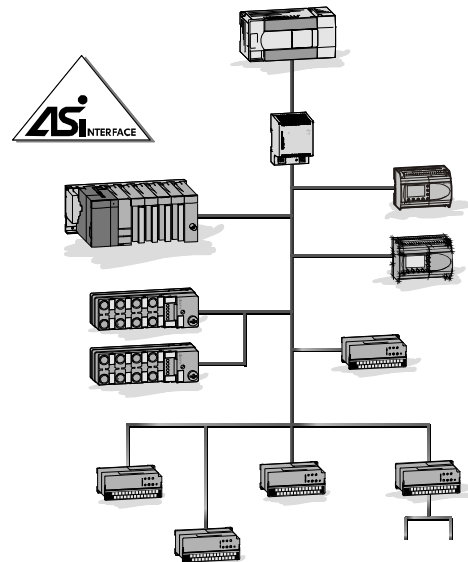

HEADQUARTERS

MITSUBISHI ELECTRIC EUROPE B.V. **EUROPE**
 German Branch
 Gothaer Straße 8
D-40880 Ratingen
 Phone: +49 (0)2102 / 486-0
 Fax: +49 (0)2102 / 486-1120

MITSUBISHI ELECTRIC EUROPE B.V. **CZECH REPUBLIC**
 Czech Branch
 Avenir Business Park, Radlická 714/113a
CZ-158 00 Praha 5
 Phone: +420 (0)251 551 470
 Fax: +420 (0)251-551-471

MITSUBISHI ELECTRIC EUROPE B.V. **FRANCE**
 French Branch
 25, Boulevard des Bouvets
F-92741 Nanterre Cedex
 Phone: +33 (0)1 / 55 68 55 68
 Fax: +33 (0)1 / 55 68 57 57

MITSUBISHI ELECTRIC EUROPE B.V. **IRELAND**
 Irish Branch
 Westgate Business Park, Ballymount
IRL-Dublin 24
 Phone: +353 (0)1 4198800
 Fax: +353 (0)1 4198890

MITSUBISHI ELECTRIC EUROPE B.V. **ITALY**
 Italian Branch
 Viale Colleoni 7
I-20041 Agrate Brianza (MB)
 Phone: +39 039 / 60 53 1
 Fax: +39 039 / 60 53 312

MITSUBISHI ELECTRIC EUROPE B.V. **POLAND**
 Poland Branch
 Ul. Krakowska 50
PL-32-083 Balice
 Phone: +48 (0)12 / 630 47 00
 Fax: +48 (0)12 / 630 47 01

MITSUBISHI ELECTRIC EUROPE B.V. **SPAIN**
 Spanish Branch
 Carretera de Rubí 76-80
E-08190 Sant Cugat del Vallés (Barcelona)
 Phone: 902 131121 // +34 935653131
 Fax: +34 935891579

MITSUBISHI ELECTRIC EUROPE B.V. **UK**
 UK Branch
 Travellers Lane
UK-Hatfield, Herts. AL10 8XB
 Phone: +44 (0)1707 / 27 61 00
 Fax: +44 (0)1707 / 27 86 95

MITSUBISHI ELECTRIC CORPORATION **JAPAN**
 Office Tower "Z" 14 F
 8-12, 1 chome, Harumi Chuo-Ku
Tokyo 104-6212
 Phone: +81 3 622 160 60
 Fax: +81 3 622 160 75

MITSUBISHI ELECTRIC AUTOMATION, Inc. **USA**
 500 Corporate Woods Parkway
Vernon Hills, IL 60061
 Phone: +1 847 478 21 00
 Fax: +1 847 478 22 53

EUROPEAN REPRESENTATIVES

GEVA **AUSTRIA**
 Wiener Straße 89
AT-2500 Baden
 Phone: +43 (0)2252 / 85 55 20
 Fax: +43 (0)2252 / 488 60

TEHNIKON **BELARUS**
 Oktyabrskaya 16/5, Off. 703-711
BY-220030 Minsk
 Phone: +375 (0)17 / 210 46 26
 Fax: +375 (0)17 / 210 46 26

ESCO DRIVES & AUTOMATION **BELGIUM**
 Culliganlaan 3
BE-1831 Diegem
 Phone: +32 (0)2 / 717 64 30
 Fax: +32 (0)2 / 717 64 31

Koning & Hartman b.v. **BELGIUM**
 Woluwelaan 31
BE-1800 Vilvoorde
 Phone: +32 (0)2 / 257 02 40
 Fax: +32 (0)2 / 257 02 49

INEA BH d.o.o. **BOSNIA AND HERZEGOVINA**
 Aleja Lipa 56
BA-71000 Sarajevo
 Phone: +387 (0)33 / 921 164
 Fax: +387 (0)33 / 524 539

AKHNATON **BULGARIA**
 4 Andrej Ljapchev Blvd. Pb 21
BG-1756 Sofia
 Phone: +359 (0)2 / 817 6004
 Fax: +359 (0)2 / 97 44 06 1

INEA CR d.o.o. **CROATIA**
 Losinjska 4 a
HR-10000 Zagreb
 Phone: +385 (0)1 / 36 940 -01 / -02 / -03
 Fax: +385 (0)1 / 36 940 -03

AutoCont C.S. s.r.o. **CZECH REPUBLIC**
 Technologická 374/6
CZ-708 00 Ostrava-Pustkovec
 Phone: +420 595 691 150
 Fax: +420 595 691 199

B:ELECTRIC, s.r.o. **CZECH REPUBLIC**
 Mladoboleslavská 812
CZ-197 00 Praha 19 - Kbely
 Phone: +420 286 850 848, +420 724 317 975
 Fax: +420 286 850 850

Beijer Electronics A/S **DENMARK**
 Lykkegårdsvej 17, 1.
DK-4000 Roskilde
 Phone: +45 (0)46 / 75 76 66
 Fax: +45 (0)46 / 75 56 26

Beijer Electronics Eesti OÜ **ESTONIA**
 Pärnu mnt.160i
EE-11317 Tallinn
 Phone: +372 (0)6 / 51 81 40
 Fax: +372 (0)6 / 51 81 49

Beijer Electronics OY **FINLAND**
 Jaakonkatu 2
FIN-01620 Vantaa
 Phone: +358 (0)207 / 463 500
 Fax: +358 (0)207 / 463 501

UTECO A.B.E.E. **GREECE**
 5, Mavrogenous Str.
GR-18542 Piraeus
 Phone: +30 211 / 1206 900
 Fax: +30 211 / 1206 999

MELTRADE Ltd. **HUNGARY**
 Fertő utca 14.
HU-1107 Budapest
 Phone: +36 (0)1 / 431-9726
 Fax: +36 (0)1 / 431-9727

Beijer Electronics SIA **LATVIA**
 Vestienas iela 2
LV-1035 Riga
 Phone: +371 (0)784 / 2280
 Fax: +371 (0)784 / 2281

Beijer Electronics UAB **LITHUANIA**
 Savanorių Pr. 187
LT-02300 Vilnius
 Phone: +370 (0)5 / 232 3101
 Fax: +370 (0)5 / 232 2980

EUROPEAN REPRESENTATIVES

ALFATRADE Ltd. **MALTA**
 99, Paola Hill
Malta- Paola PLA 1702
 Phone: +356 (0)21 / 697 816
 Fax: +356 (0)21 / 697 817

INTEHSIS srl **MOLDOVA**
 bld. Traian 23/1
MD-2060 Kishinev
 Phone: +373 (0)22 / 66 4242
 Fax: +373 (0)22 / 66 4280

HIFLEX AUTOM.TECHNIEK B.V. **NETHERLANDS**
 Wolweverstraat 22
NL-2984 CD Ridderkerk
 Phone: +31 (0)180 - 46 60 04
 Fax: +31 (0)180 - 44 23 55

Koning & Hartman b.v. **NETHERLANDS**
 Haarlbergweg 21-23
NL-1101 CH Amsterdam
 Phone: +31 (0)20 / 587 76 00
 Fax: +31 (0)20 / 587 76 05

Beijer Electronics AS **NORWAY**
 Postboks 487
NO-3002 Drammen
 Phone: +47 (0)32 / 24 30 00
 Fax: +47 (0)32 / 84 85 77

Sirius Trading & Services srl **ROMANIA**
 Aleea Lacul Morii Nr. 3
RO-060841 Bucuresti, Sector 6
 Phone: +40 (0)21 / 430 40 06
 Fax: +40 (0)21 / 430 40 02

Craft Con. & Engineering d.o.o. **SERBIA**
 Bulevar Svetog Cara Konstantina 80-86
SER-18106 Nis
 Phone: +381 (0)18 / 292-24-4/5
 Fax: +381 (0)18 / 292-24-4/5

INEA SR d.o.o. **SERBIA**
 Izletnicka 10
SER-113000 Smederevo
 Phone: +381 (0)26 / 617 163
 Fax: +381 (0)26 / 617 163

AutoCont Control s.r.o. **SLOVAKIA**
 Radlinského 47
SK-02601 Dolny Kubin
 Phone: +421 (0)43 / 5868210
 Fax: +421 (0)43 / 5868210

CS MTrade Slovensko, s.r.o. **SLOVAKIA**
 Vajanskeho 58
SK-92101 Piestany
 Phone: +421 (0)33 / 7742 760
 Fax: +421 (0)33 / 7735 144

INEA d.o.o. **SLOVENIA**
 Stegne 11
SI-1000 Ljubljana
 Phone: +386 (0)1 / 513 8100
 Fax: +386 (0)1 / 513 8170

Beijer Electronics AB **SWEDEN**
 Box 426
SE-20124 Malmö
 Phone: +46 (0)40 / 35 86 00
 Fax: +46 (0)40 / 35 86 02

Econotec AG **SWITZERLAND**
 Hinterdorfstr. 12
CH-8309 Nürensdorf
 Phone: +41 (0)44 / 838 48 11
 Fax: +41 (0)44 / 838 48 12

GTS **TURKEY**
 Bayraktar Bulvari Nutuk Sok. No:5
TR-34775 Yukari Dudullu-Umraniye-ISTANBUL
 Phone: +90 (0)216 526 39 90
 Fax: +90 (0)216 526 3995

CSC Automation Ltd. **UKRAINE**
 4-B, M. Raskovoyi St.
UA-02660 Kiev
 Phone: +380 (0)44 / 494 33 55
 Fax: +380 (0)44 / 494-33-66

EURASIAN REPRESENTATIVES

Kazpromautomatiks Ltd. **KAZAKHSTAN**
 Mustafina Str. 7/2
KAZ-470046 Karaganda
 Phone: +7 7212 / 50 11 50
 Fax: +7 7212 / 50 11 50

MIDDLE EAST REPRESENTATIVES

TEXEL ELECTRONICS Ltd. **ISRAEL**
 2 Ha'umanut, P.O.B. 6272
IL-42160 Netanya
 Phone: +972 (0)9 / 863 39 80
 Fax: +972 (0)9 / 885 24 30

CEG INTERNATIONAL **LEBANON**
 Cebaco Center/Block A Autostrade DORA
Lebanon - Beirut
 Phone: +961 (0)1 / 240 430
 Fax: +961 (0)1 / 240 438

AFRICAN REPRESENTATIVE

CBI Ltd. **SOUTH AFRICA**
 Private Bag 2016
ZA-1600 Isando
 Phone: +27 (0)11 / 928 2000
 Fax: +27 (0)11 / 392 2354