

Highly Stable Pressure Sensor, 0-70kPa,
Gauge, Compensated, 19mm diameter



PS781 Series IOT Pressure Sensors Technical Data Sheet

PS781-02G0L1

Features

- Pressure range 0-70kPa
- Gauge pressure sensor
- Constant current / Constant Voltage power supply
- Isolated construction, enable to measure various media
- F19mm standard OEM pressure sensor
- Full stainless steel 316L
- Wide temperature compensation
- Long-term stability $\pm 0.1\%$ FS/year

Applications

- Industrial process control
- Level measurement
- Pressure checking meter
- Pressure calibrator
- Liquid pressure system and switch
- Cooling equipment and air conditioning system
- Aviation and navigation inspection

Description

PS781-02G0L1 is a highly stable piezo-resistive pressure sensor with wide temperature compensation and zero correction. It contains a highly stable silicon die, stainless steel 316L housing with diameter 19mm. The measured pressure is transmitted onto the silicon die through the 316L diaphragm and inner media. This transforms the measured pressure into an electrical signal.

Product Configuration

Application:	Highly Stable Pressure Sensor
Pressure Type:	Gauge
Electrical Connector:	0.5mm Kovar Pin

General Specifications*

Description	Minimum	Typical	Maximum	Unit
Pressure Range	0		70	kPa
Linearity		± 0.15	± 0.2	% Full Scale
Repeatability		± 0.05	± 0.075	% Full Scale
Hysteresis		± 0.05	± 0.075	% Full Scale
Full Scale Output	70			mV DC
Zero Output			2	mV DC
Zero Thermal Error @35°C		± 0.75	± 1	% Full Scale/°C
Span Thermal Error @35°C		± 0.75	± 1	% Full Scale/°C
Compensated Temp Range	-10		80	°C
Long Term Stability		± 0.1	± 0.2	%Full Scale/year
Overpressure		1.5		xFull Scale

*General Specifications hold under the following Nominal Conditions



an INFINIT® brand

Highly Stable Pressure Sensor, 0-70kPa,
Gauge, Compensated, 19mm diameter



PS781 Series IOT Pressure Sensors Technical Data Sheet

PS781-02G0L1

*Nominal Conditions

DESCRIPTION	DESCRIPTION
Media Temperature: (35±1)°C	Environment Temperature: (35±1)°C
Shock: 0.1g(1m/s²)Max	Humidity: (50%±10%)RH
Local air pressure: (86-106)kPa	Power supply: (1.5±0.0015)mADC

Electrical Specifications

Description	Minimum	Typical	Maximum	Unit
Power Supply/Excitation Level			10	VDC
Power Supply Current			2	mA
Input Impedance	2,000		6,000	Ω
Output Impedance	3,500		6,000	Ω
Response 10%-90%			1	msec
Insulation Resistance 100VDC		100		MΩ

Material Specifications

Description	Material
Diaphragm	Stainless Steel 316L
Plug Housing	Stainless Steel 316L
Tubing	Stainless Steel 316L
Pin	Kovar
O-Ring	Viton

Mechanical Specifications

Weight 0.035 lbs [15.88 g]



an INFINIT[®] brand

Highly Stable Pressure Sensor, 0-70kPa,
Gauge, Compensated, 19mm diameter



PS781 Series IOT Pressure Sensors Technical Data Sheet

PS781-02G0L1

Electrical Connection

Pin	Connection	Wire Color
4	-OUT	Blue
5	-IN	Yellow
8	+IN	Black
9	+Out	Red

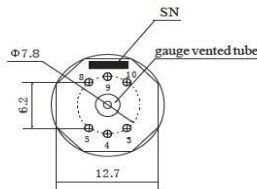

Environmental Specifications

Temperature (Operating)	-40°C to 125°C
Temperature (Storage)	-40°C to 125°C
Shock	No change at 10gRMS, (20-2000)Hz
Impact	100g, 11ms

Notes: Media compatibility-the gas or liquid which is compatible with stainless steel and Viton

Certifications	ROHS Compliant
	CE Compliant

The Infinite Electronics portfolio includes coaxial cable assemblies, connectors, adapters and custom products, as well as our wireless product line which includes antennas, RF amplifiers, lightning and surge protectors, and NEMA rated enclosures.

The information contained in this document is accurate to the best of our knowledge and representative of the part described herein. It may be necessary to make modifications to the part and/or the documentation of the part, in order to implement improvements. L-com reserves the right to make such changes as required. Unless otherwise stated, all specifications are nominal. L-com does not make any representation or warranty regarding the suitability of the part described herein for any particular purpose, and L-com does not assume any liability arising out of the use of any part or documentation.

PS781-02G0L1 CAD Drawing

Highly Stable Pressure Sensor, 0-70kPa, Gauge, Compensated, 19mm diameter

REV	DESCRIPTION	DATE	APPROVED
B	ECN 10065; ADDED VENT TUBE, DIM WAS 16 mm	08/27/19	TO/A

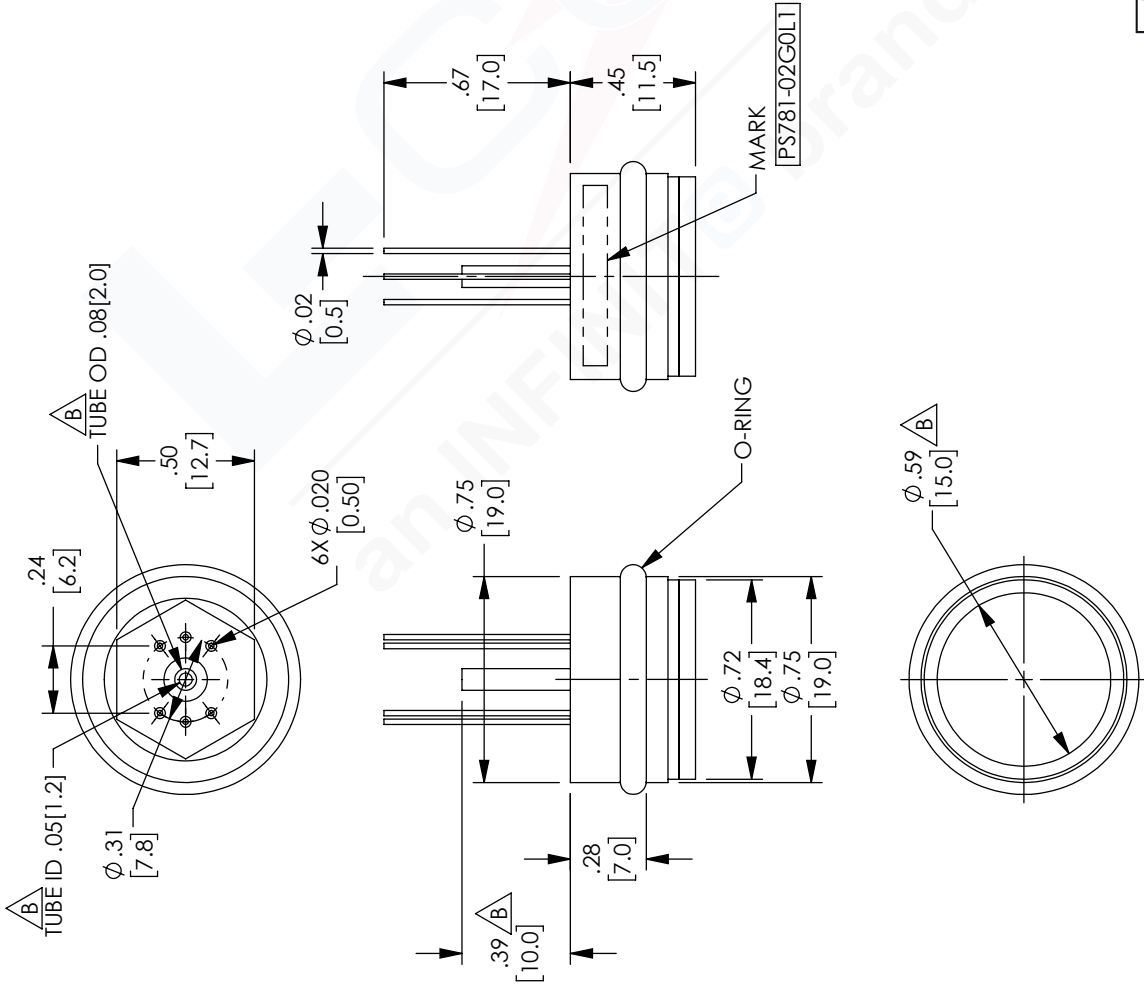

UNLESS OTHERWISE SPECIFIED LENGTH DIMENSIONS ARE IN INCHES DIMENSIONS IN PARENTHESES ARE IN MILLIMETERS		THE INFORMATION AND DESIGN IN THIS DOCUMENT IS THE PROPERTY OF L-COM. ALL RIGHTS RESERVED.	
TOLERANCES: .X±.2 [5.08] FRACTIONS .XX±.01 [25] ± 1/32 .XXX±.005 [13] ANGLES ± 1°		SHEET 1 OF 1	
ALL DIMENSIONS SHOWN ARE FOR REFERENCE ONLY. THIRD-ANGLE PROJECTION		SCALE N/A	
www.L-com.com e-mail: CustomerService@L-com.com		DRAWN BY DZINN	
SIZE A	CAGE NUMBER 43321	PART NUMBER PS781-02G0L1	REV B

INFINITT brand
50 High Street, West Mill, 3rd Floor, Suite #30
North Andover, MA 01845 USA
Phone: 1 800 341 5266 | 1 978 682 6936
Fax: 1 978 689 9484

THESE COMMODITIES, TECHNOLOGY OR SOFTWARE WERE EXPORTED FROM THE UNITED STATES IN ACCORDANCE WITH THE EXPORT ADMINISTRATION REGULATIONS. DIVERSION CONTRARY TO U.S. LAW PROHIBITED.