



SIRIUS soft starter 200-600 V 210 A, 24 V AC/DC spring-type terminals Thermistor input

product brand name	SIRIUS
product category	Hybrid switching devices
product designation	Soft starter
product type designation	3RW52
manufacturer's article number	<ul style="list-style-type: none"> • of standard HMI module usable 3RW5980-0HS00 • of high feature HMI module usable 3RW5980-0HF00 • of communication module PROFINET standard usable 3RW5980-0CS00 • of communication module PROFIBUS usable 3RW5980-0CP00 • of communication module Modbus TCP usable 3RW5980-0CT00 • of communication module Modbus RTU usable 3RW5980-0CR00 • of communication module Ethernet/IP 3RW5980-0CE00 • of circuit breaker usable at 400 V 3VA2325-7MN32-0AA0: Type of coordination 1, Iq = 65 kA, CLASS 10 • of circuit breaker usable at 500 V 3VA2325-7MN32-0AA0: Type of coordination 1, Iq = 65 kA, CLASS 10 • of circuit breaker usable at 400 V at inside-delta circuit 3VA2440-7MN32-0AA0: Type of coordination 1, Iq = 65 kA, CLASS 10 • of circuit breaker usable at 500 V at inside-delta circuit 3VA2440-7MN32-0AA0: Type of coordination 1, Iq = 65 kA, CLASS 10 • of the gG fuse usable up to 690 V 2x3NA3354-6; Type of coordination 1, Iq = 65 kA • of the gG fuse usable at inside-delta circuit up to 500 V 2x3NA3354-6; Type of coordination 1, Iq = 65 kA • of full range R fuse link for semiconductor protection usable up to 690 V 3NE1230-2: Type of coordination 2, Iq = 65 kA • of back-up R fuse link for semiconductor protection usable up to 690 V 3NE3333: Type of coordination 2, Iq = 65 kA
General technical data	
starting voltage [%]	30 ... 100 %
stopping voltage [%]	50 %; non-adjustable
start-up ramp time of soft starter	0 ... 20 s
current limiting value [%] adjustable	130 ... 700 %
certificate of suitability	<ul style="list-style-type: none"> • CE marking Yes • UL approval Yes • CSA approval Yes
product component	<ul style="list-style-type: none"> • HMI-High Feature No • is supported HMI-Standard Yes • is supported HMI-High Feature Yes
product feature integrated bypass contact system	Yes
number of controlled phases	3
buffering time in the event of power failure	<ul style="list-style-type: none"> • for main current circuit 100 ms • for control circuit 100 ms
insulation voltage rated value	600 V
degree of pollution	3, acc. to IEC 60947-4-2
impulse voltage rated value	6 kV
blocking voltage of the thyristor maximum	1 600 V
service factor	1
surge voltage resistance rated value	6 kV
maximum permissible voltage for protective separation	<ul style="list-style-type: none"> • between main and auxiliary circuit 600 V

shock resistance	15 g / 11 ms, from 12 g / 11 ms with potential contact lifting
vibration resistance	15 mm to 6 Hz; 2 g to 500 Hz
utilization category according to IEC 60947-4-2	AC 53a
reference code according to IEC 81346-2	Q
Substance Prohibitance (day/month/year)	02/15/2018
SVHC substance name	Lead CAS-No. 7439-92-1 Lead monoxide (lead oxide) CAS-No. 1317-36-8 2,2',6,6'-tetrabromo-4,4'-isopropylidenediphenol CAS-No. 79-94-7 2-methyl-1-(4-methylthiophenyl)-2-morpholinopropan-1-one CAS-No. 71868-10-5 Melamine CAS-No. 108-78-1 6,6'-di-tert-butyl-2,2'-methylenedi-p-cresol CAS-No. 119-47-1 Dibutylbis(pentane-2,4-dionato-O,O')tin CAS-No. 22673-19-4
Net Weight	9.9 kg
product function	
<ul style="list-style-type: none"> ● ramp-up (soft starting) ● soft stopping ● Soft Torque ● adjustable current limitation ● pump stop ● intrinsic device protection ● motor overload protection ● evaluation of thermistor motor protection ● inside-delta circuit ● auto-RESET ● manual RESET ● remote reset ● communication function ● operating measured value display ● error logbook ● via software parameterizable ● via software configurable ● PROFInergy ● firmware update ● removable terminal for control circuit ● torque control ● analog output 	<ul style="list-style-type: none"> Yes Yes Yes Yes Yes Yes Yes; Full motor protection (thermistor motor protection and electronic motor overload protection) Yes; Type A PTC or Klixon / Thermoclick Yes Yes Yes Yes; By turning off the control supply voltage Yes Yes; Only in conjunction with special accessories Yes; Only in conjunction with special accessories No Yes Yes; in connection with the PROFINET Standard communication module Yes Yes No No
Power Electronics	
operational current	
<ul style="list-style-type: none"> ● at 40 °C rated value ● at 50 °C rated value ● at 60 °C rated value 	<ul style="list-style-type: none"> 210 A 186 A 170 A
operational current at inside-delta circuit	
<ul style="list-style-type: none"> ● at 40 °C rated value ● at 50 °C rated value ● at 60 °C rated value 	<ul style="list-style-type: none"> 364 A 322 A 294 A
operating voltage	
<ul style="list-style-type: none"> ● rated value ● at inside-delta circuit rated value 	<ul style="list-style-type: none"> 200 ... 600 V 200 ... 600 V
relative negative tolerance of the operating voltage	-15 %
relative positive tolerance of the operating voltage	10 %
relative negative tolerance of the operating voltage at inside-delta circuit	-15 %
relative positive tolerance of the operating voltage at inside-delta circuit	10 %
operating power for 3-phase motors	
<ul style="list-style-type: none"> ● at 230 V at 40 °C rated value ● at 230 V at inside-delta circuit at 40 °C rated value ● at 400 V at 40 °C rated value ● at 400 V at inside-delta circuit at 40 °C rated value ● at 500 V at 40 °C rated value 	<ul style="list-style-type: none"> 55 kW 110 kW 110 kW 200 kW 132 kW

● at 500 V at inside-delta circuit at 40 °C rated value	250 kW
Operating frequency 1 rated value	50 Hz
Operating frequency 2 rated value	60 Hz
relative negative tolerance of the operating frequency	-10 %
relative positive tolerance of the operating frequency	10 %
adjustable motor current	
● at rotary coding switch on switch position 1	90 A
● at rotary coding switch on switch position 2	98 A
● at rotary coding switch on switch position 3	106 A
● at rotary coding switch on switch position 4	114 A
● at rotary coding switch on switch position 5	122 A
● at rotary coding switch on switch position 6	130 A
● at rotary coding switch on switch position 7	138 A
● at rotary coding switch on switch position 8	146 A
● at rotary coding switch on switch position 9	154 A
● at rotary coding switch on switch position 10	162 A
● at rotary coding switch on switch position 11	170 A
● at rotary coding switch on switch position 12	178 A
● at rotary coding switch on switch position 13	186 A
● at rotary coding switch on switch position 14	194 A
● at rotary coding switch on switch position 15	202 A
● at rotary coding switch on switch position 16	210 A
● minimum	90 A
adjustable motor current	
● for inside-delta circuit at rotary coding switch on switch position 1	156 A
● for inside-delta circuit at rotary coding switch on switch position 2	170 A
● for inside-delta circuit at rotary coding switch on switch position 3	184 A
● for inside-delta circuit at rotary coding switch on switch position 4	197 A
● for inside-delta circuit at rotary coding switch on switch position 5	211 A
● for inside-delta circuit at rotary coding switch on switch position 6	225 A
● for inside-delta circuit at rotary coding switch on switch position 7	239 A
● for inside-delta circuit at rotary coding switch on switch position 8	253 A
● for inside-delta circuit at rotary coding switch on switch position 9	267 A
● for inside-delta circuit at rotary coding switch on switch position 10	281 A
● for inside-delta circuit at rotary coding switch on switch position 11	294 A
● for inside-delta circuit at rotary coding switch on switch position 12	308 A
● for inside-delta circuit at rotary coding switch on switch position 13	322 A
● for inside-delta circuit at rotary coding switch on switch position 14	336 A
● for inside-delta circuit at rotary coding switch on switch position 15	350 A
● for inside-delta circuit at rotary coding switch on switch position 16	364 A
● at inside-delta circuit minimum	156 A
minimum load [%]	15 %; Relative to smallest settable le
power loss [W] for rated value of the current at AC	
● at 40 °C after startup	75 W
● at 50 °C after startup	68 W
● at 60 °C after startup	63 W
power loss [W] at AC at current limitation 350 %	
● at 40 °C during startup	3 562 W

<ul style="list-style-type: none"> at 50 °C during startup at 60 °C during startup 	2 979 W 2 617 W
Control circuit/ Control	
type of voltage of the control supply voltage	AC/DC
control supply voltage at AC	
<ul style="list-style-type: none"> at 50 Hz rated value at 60 Hz rated value 	24 V 24 V
relative negative tolerance of the control supply voltage at AC at 50 Hz	-20 %
relative positive tolerance of the control supply voltage at AC at 50 Hz	20 %
relative negative tolerance of the control supply voltage at AC at 60 Hz	-20 %
relative positive tolerance of the control supply voltage at AC at 60 Hz	20 %
control supply voltage frequency	50 ... 60 Hz
relative negative tolerance of the control supply voltage frequency	-10 %
relative positive tolerance of the control supply voltage frequency	10 %
control supply voltage at DC rated value	24 V
relative negative tolerance of the control supply voltage at DC	-20 %
relative positive tolerance of the control supply voltage at DC	20 %
control supply current in standby mode rated value	160 mA
holding current in bypass operation rated value	470 mA
inrush current by closing the bypass contacts maximum	7.6 A
inrush current peak at application of control supply voltage maximum	3.3 A
duration of inrush current peak at application of control supply voltage	12.1 ms
design of the overvoltage protection	Varistor
design of short-circuit protection for control circuit	4 A gG fuse (I _{cu} =1 kA), 6 A quick-acting fuse (I _{cu} =1 kA), C1 miniature circuit breaker (I _{cu} = 600 A), C6 miniature circuit breaker (I _{cu} = 300 A); Is not part of scope of supply
Inputs/ Outputs	
number of digital inputs	1
number of digital outputs	3
<ul style="list-style-type: none"> not parameterizable 	2
digital output version	2 normally-open contacts (NO) / 1 changeover contact (CO)
number of analog outputs	0
switching capacity current of the relay outputs	
<ul style="list-style-type: none"> at AC-15 at 250 V rated value at DC-13 at 24 V rated value 	3 A 1 A
Installation/ mounting/ dimensions	
mounting position	with vertical mounting surface +/-90° rotatable, with vertical mounting surface +/- 22.5° tiltable to the front and back
fastening method	screw fixing
height	393 mm
width	210 mm
depth	203 mm
required spacing with side-by-side mounting	
<ul style="list-style-type: none"> forwards backwards upwards downwards at the side 	10 mm 0 mm 100 mm 75 mm 5 mm
weight without packaging	9.9 kg
Connections/ Terminals	
type of electrical connection	
<ul style="list-style-type: none"> for main current circuit 	busbar connection

<ul style="list-style-type: none"> • for control circuit 	spring-loaded terminals
width of connection bar maximum	45 mm
wire length for thermistor connection	
<ul style="list-style-type: none"> • with conductor cross-section = 0.5 mm² maximum 	50 m
<ul style="list-style-type: none"> • with conductor cross-section = 1.5 mm² maximum 	150 m
<ul style="list-style-type: none"> • with conductor cross-section = 2.5 mm² maximum 	250 m
type of connectable conductor cross-sections	
<ul style="list-style-type: none"> • for DIN cable lug for main contacts stranded 	2x (50 ... 240 mm ²)
<ul style="list-style-type: none"> • for DIN cable lug for main contacts finely stranded 	2x (70 ... 240 mm ²)
type of connectable conductor cross-sections	
<ul style="list-style-type: none"> • for control circuit solid 	2x (0.25 ... 1.5 mm ²)
<ul style="list-style-type: none"> • for control circuit finely stranded with core end processing 	2x (0.25 ... 1.5 mm ²)
<ul style="list-style-type: none"> • for AWG cables for control circuit solid 	2x (24 ... 16)
<ul style="list-style-type: none"> • for AWG cables for control circuit finely stranded with core end processing 	2x (24 ... 16)
wire length	
<ul style="list-style-type: none"> • between soft starter and motor maximum 	800 m
<ul style="list-style-type: none"> • at the digital inputs at AC maximum 	100 m
<ul style="list-style-type: none"> • at the digital inputs at DC maximum 	1 000 m
tightening torque	
<ul style="list-style-type: none"> • for main contacts with screw-type terminals 	14 ... 24 N·m
<ul style="list-style-type: none"> • for auxiliary and control contacts with screw-type terminals 	0.8 ... 1.2 N·m
tightening torque [lbf·in]	
<ul style="list-style-type: none"> • for main contacts with screw-type terminals 	124 ... 210 lbf·in
<ul style="list-style-type: none"> • for auxiliary and control contacts with screw-type terminals 	7 ... 10.3 lbf·in
Ambient conditions	
installation altitude at height above sea level maximum	5 000 m
ambient temperature	
<ul style="list-style-type: none"> • during operation 	-25 ... +60 °C; Please observe derating at temperatures of 40 °C or above
<ul style="list-style-type: none"> • during storage and transport 	-40 ... +80 °C
environmental category	
<ul style="list-style-type: none"> • during operation according to IEC 60721 	3K6 (no ice formation, only occasional condensation), 3C3 (no salt mist), 3S2 (sand must not get into the devices), 3M6
<ul style="list-style-type: none"> • during storage according to IEC 60721 	1K6 (only occasional condensation), 1C2 (no salt mist), 1S2 (sand must not get inside the devices), 1M4
<ul style="list-style-type: none"> • during transport according to IEC 60721 	2K2, 2C1, 2S1, 2M2 (max. fall height 0.3 m)
Electromagnetic compatibility	
EMC emitted interference	acc. to IEC 60947-4-2: Class A
Communication/ Protocol	
communication module is supported	
<ul style="list-style-type: none"> • PROFINET standard 	Yes
<ul style="list-style-type: none"> • EtherNet/IP 	Yes
<ul style="list-style-type: none"> • Modbus RTU 	Yes
<ul style="list-style-type: none"> • Modbus TCP 	Yes
<ul style="list-style-type: none"> • PROFIBUS 	Yes
UL/CSA ratings	
manufacturer's article number	
<ul style="list-style-type: none"> • of circuit breaker usable for Standard Faults <ul style="list-style-type: none"> — at 460/480 V according to UL — 60/480 V according to UL — at 460/480 V at inside-delta circuit according to UL — 60/480 V at inside-delta circuit according to UL — at 575/600 V according to UL — at 575/600 V at inside-delta circuit according to UL 	Siemens type: 3VA53, max. 400 A or 3VA54, max. 600 A; Iq = 10 kA Siemens type: 3VA53, max. 400 A or 3VA54, max. 600 A; Iq max = 65 kA Siemens type: 3VA53, max. 400 A or 3VA54, max. 600 A; Iq = 10 kA Siemens type: 3VA53, max. 400 A or 3VA54, max. 600 A; Iq max = 65 kA Siemens type: 3VA53, max. 400 A or 3VA54, max. 600 A; Iq = 10 kA Siemens type: 3VA53, max. 400 A or 3VA54, max. 600 A; Iq = 10 kA
<ul style="list-style-type: none"> • of the fuse <ul style="list-style-type: none"> — usable for Standard Faults up to 575/600 V according to UL — usable for High Faults up to 575/600 V according to UL 	Type: Class J / L, max. 700 A; Iq = 10 kA Type: Class J / L, max. 700 A; Iq = 100 kA

— usable for Standard Faults at inside-delta circuit up to 575/600 V according to UL
 — usable for High Faults at inside-delta circuit up to 575/600 V according to UL

Type: Class J / L, max. 700 A; Iq = 10 kA
 Type: Class J / L, max. 700 A; Iq = 100 kA

operating power [hp] for 3-phase motors

- at 200/208 V at 50 °C rated value 60 hp
- at 220/230 V at 50 °C rated value 60 hp
- at 460/480 V at 50 °C rated value 150 hp
- at 575/600 V at 50 °C rated value 150 hp
- at 200/208 V at inside-delta circuit at 50 °C rated value 100 hp
- at 220/230 V at inside-delta circuit at 50 °C rated value 125 hp
- at 460/480 V at inside-delta circuit at 50 °C rated value 250 hp
- at 575/600 V at inside-delta circuit at 50 °C rated value 300 hp

contact rating of auxiliary contacts according to UL R300-B300

Electrical Safety

protection class IP on the front according to IEC 60529 IP00; IP20 with cover

touch protection on the front according to IEC 60529 finger-safe, for vertical contact from the front with cover

Approvals Certificates

Environmental Product Declaration

- global warming potential [CO2 eq] / during manufacturing 84.2 kg
- global warming potential [CO2 eq] / during sales 2.81 kg
- global warming potential [CO2 eq] / during operation 721 kg
- global warming potential [CO2 eq] / after end of life -21.8 kg
- global warming potential [CO2 eq] / total 786 kg

Environment

General Product Approval

[Environmental Confirmations](#)



General Product Approval

EMV

Test Certificates

Maritime application



Maritime application

other



other



Further information

Information on the packaging
<https://support.industry.siemens.com/cs/ww/en/view/109813875>
 Information for data generation and storage
<https://support.industry.siemens.com/cs/ww/en/view/109995012>
 Information- and Downloadcenter (Catalogs, Brochures,...)
<https://www.siemens.com/ic10>
 Industry Mall (Online ordering system)
<https://mall.industry.siemens.com/mall/en/en/Catalog/product?mlfb=3RW5243-2TC05>
 Service&Support (Manuals, Certificates, Characteristics, FAQs,...)

<https://support.industry.siemens.com/cs/ww/en/ps/3RW5243-2TC05>

Image database (product images, 2D dimension drawings, 3D models, device circuit diagrams, EPLAN macros, ...)

https://www.automation.siemens.com/bilddb/cax_de.aspx?mlfb=3RW5243-2TC05&lang=en

Cax online generator

<https://support.automation.siemens.com/WW/CAXorder/default.aspx?lang=en&mlfb=3RW5243-2TC05>

Characteristic curves

[https://curves.simaris.siemens.com/curves/<mmp_prod_noCOMP="HAUPT"></mmp_prod_no>](https://curves.simaris.siemens.com/curves/<mmp_prod_noCOMP=)

Characteristic: Tripping characteristics, I^t, Let-through current

<https://support.industry.siemens.com/cs/ww/en/ps/3RW5243-2TC05/char>

Characteristic: Installation altitude

https://www.automation.siemens.com/bilddb/index.aspx?gridview=view2&objkey=G_NSB0_XX_01704&showdetail=true&view=Search

Simulation Tool for Soft Starters (STS)

<https://support.industry.siemens.com/cs/ww/en/view/101494917>

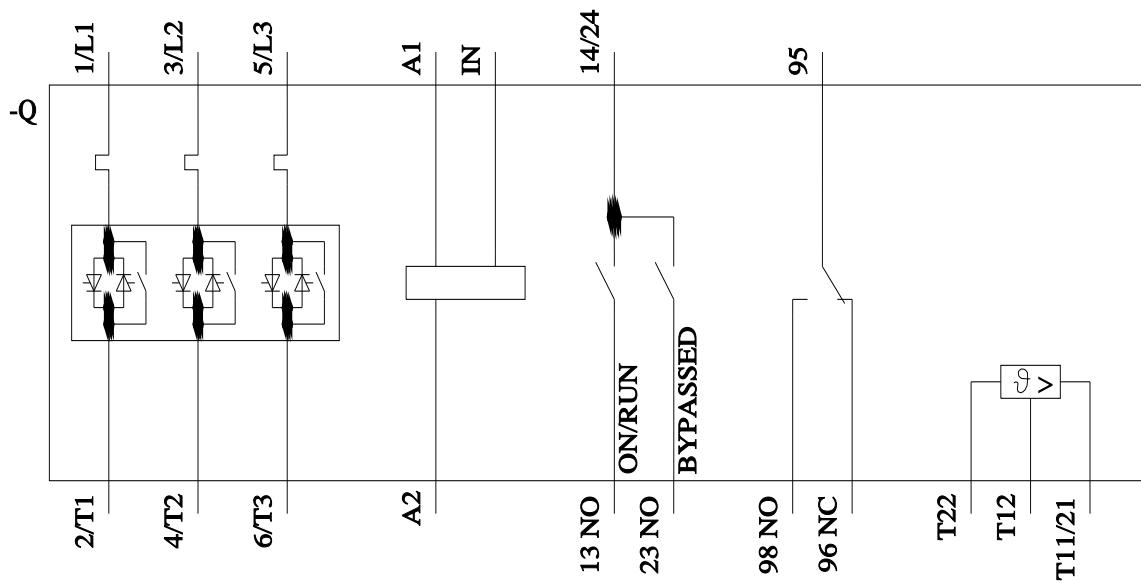

last modified:

4/4/2026

