

## I/O Terminal Sockets to Flexibly Build Systems

- Mount either G7T I/O Relays or G3TA SSRs.
- Compact size for both Input and Output I/O Terminal Sockets: 182 (102 for 8 I/O points) (W) × 85 (D) × 68 (H) mm.
- Surge absorption circuits provided.
- LED indicators as a standard feature.
- DIN Track mounting.

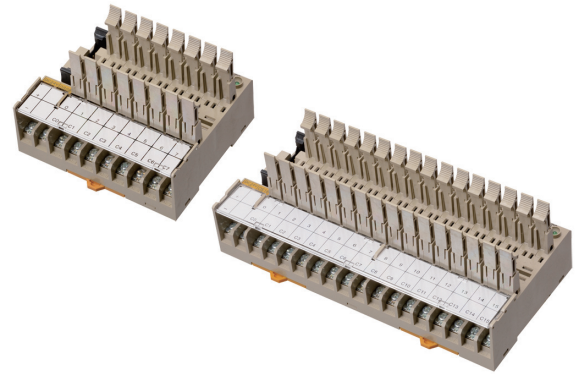

## Ordering Information

### I/O Terminal Sockets

When ordering, specify the rated voltage.

I/O classification	I/O points	Internal I/O common	Rated voltage	Model
For inputs	16	NPN (– common)	12 VDC	P7TF-IS16 DC12
			24 VDC	P7TF-IS16 DC24
			100/110 VDC	P7TF-IS16 DC100/110
			100/110 VAC	P7TF-IS16 AC100/110
			200/220 VAC	P7TF-IS16 AC200/220
For outputs	16	NPN (+ common)	12 VDC	P7TF-OS16 DC12
			24 VDC	P7TF-OS16 DC24
		PNP (– common)	12 VDC	P7TF-OS16-1 DC12
			24 VDC	P7TF-OS16-1 DC24
	8	NPN (+ common)	12 VDC	P7TF-OS08 DC12
			24 VDC	P7TF-OS08 DC24

## Accessories (Order Separately)

### Cables for I/O Relay Terminals

- Cables with Loose Wires and Crimp Terminals: XW2Z-RY□□
- Cables with Loose Wires: XW2Z-RA□□C
- Cables with Connectors: XW2Z-R□□C-□-□
- Cables with Connectors (1:2): XW2Z-RO□□C-□ and XW2Z-RI□□C-□
- Cables with Connectors (1:1): XW2Z-R□□C

Refer to the XW2Z-R Datasheet for details.

### Shorting Bar

Model
G78-04

### Output Short-Circuit Module

Model
G77-S

### Sockets

Model
P7TF-05

### Indicator Module

#### (with Surge Suppressing Function)

Type	Applicable relay coil voltage	Model	Remarks
For AC Relays	100 (110) VAC	P70A AC100/110	Varistors
	200 (220) VAC	P70A AC200/220	
For DC Relays	12/24 VDC	P70D DC12/24	Diodes

**Note:** 1. Order the Indicator Module that is suited to the Relay coil voltage.

2. The Indicator Module for DC Relays has a multiple power supply common to 12 and 24 VDC.

3. The input current is as given below (reference values).  
 100/110 VAC: 1.14 to 1.38 mA  
 200/220 VAC: 1.40 to 1.71 mA  
 12/24 VDC: 4.83 to 5.90 mA

4. Weight: Approx. 6 g

### Accessories for DIN Track Mounting

Refer to your OMRON website for details on the PFP-□.

## Accessories (Order Separately)

### Mountable I/O Relays

I/O classification	Rated coil voltage	Contact structure	Case color	Rated load (resistive load)	Model
For inputs	12 VDC	SPST-NO	Transparent green	1 A at 24 VDC 1 A at 110 VAC	G7T-1122S DC12 *
	24 VDC				G7T-1122S DC24 *
	100/110 VDC				G7T-1122S DC100/110 *
	100/110 VAC		G7T-1122S AC100/110 *		
	200/220 VAC		G7T-1122S AC200/220 *		
For outputs	12 VDC	SPST-NC	Transparent red	5 A at 24 VDC 2 A at 220 VAC	G7T-1112S DC12 *
	24 VDC				G7T-1112S DC24 *
	12 VDC		Transparent		G7T-1012S DC12
	24 VDC				G7T-1012S DC24

### Mountable I/O SSRs

I/O classification	Rated input voltage	Isolation	Operation indicator	Zero cross function	Applicable load	Model
For inputs	5 to 24 VDC	Photocoupler	Yes	---	Logic level supply current: 25 mA	G3TA-IDZR02S DC5-24
	4 to 24 VDC		No			G3TA-IDZR02SM
	100 to 240 VAC		Yes			G3TA-IAZR02S AC100-240
For outputs	12 VDC	Phototriac	Yes	Yes	2 A at 100 to 240 VAC	G3TA-OA202SZ DC12
	24 VDC					G3TA-OA202SZ DC24
	12 VDC					No
	24 VDC	G3TA-OA202SL DC24				
	12 VDC	Photocoupler	Yes	---	2 A at 5 to 48 VDC	G3TA-ODX02S DC12
	24 VDC					G3TA-ODX02S DC24
	12 VDC				1 A at 48 to 200 VDC	G3TA-OD201S DC12
	24 VDC					G3TA-OD201S DC24

**Note:** "For inputs" and "for outputs" indicate the I/O relationship to a PLC.

Input Relays and SSRs are mainly suitable for input signals to a PLC or other device. Output Relays are mainly suitable to switching loads that receive output signals from a PLC or other device. The Input and Output Relays and SSRs have different switching performances. Select a suitable Relay for the application.

\* Mounted as standard features to G7TC I/O Relay Terminals.

## Specifications

Item	Model	P7TF-IS16 AC	P7TF-IS16 DC	P7TF-OS16 P7TF-OS16-1	P7TF-OS08
Contact resistance*		10 mΩ max.			
Terminal block	Permissible current	100 mA		10 A	
	Dielectric strength	1,000 VAC, 50/60 Hz for 1 minute		2,000 VAC, 50/60 Hz for 1 minute	
	Insulation resistance	100 MΩ min. (at 500 VDC)		1,000 MΩ min. (at 500 VDC)	
Vibration resistance		10 to 55 Hz with 1.0-mm double amplitude			
Shock resistance		200m/s <sup>2</sup>			
Noise immunity		Noise level: 1.6 kV; pulse width: 100 ns to 1 μs			
Ambient operating temperature		0 to 55°C (with no icing or condensation)			
Ambient operating humidity		35% to 85%			
Tightening torque for external connections		0.78 to 1.17 N·m			
LED color		Red	Green		
Coil surge absorption element		Varistors	Diodes (1 A, 400 V)		
Protection diode for inverse connection		Diodes (2 A, Reverse withstand voltage: 400 V)			
Weight		Approx. 360 g		Approx. 400 g	Approx. 350 g

**Note:** The above values are initial values.

\* Measurement: 1 A at 5 VDC.

# Internal Circuits

## P7TF-IS16

For AC

(NPN input/- common)

Connector Pin Configuration  
Top View

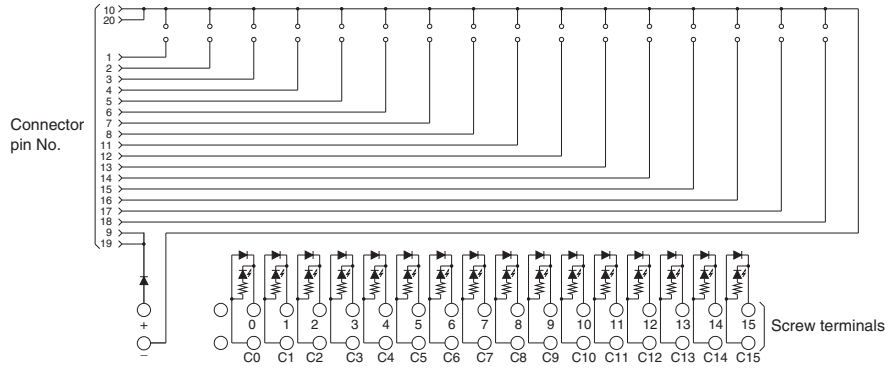
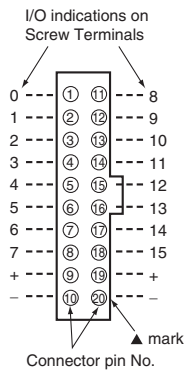

For DC

(NPN input/- common)

Connector Pin Configuration  
Top View

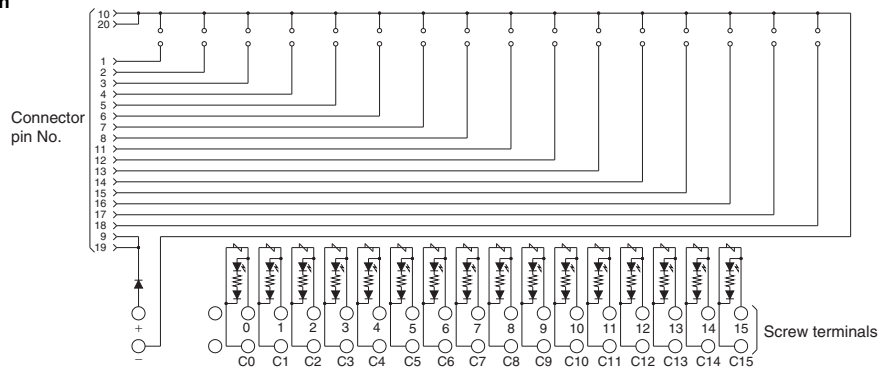
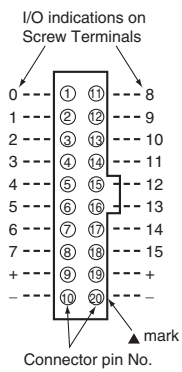

**Note:** Pin numbers are indicated for convenience. The ▲ mark can be used to determine orientation.

**P7TF-OS16**  
(NPN output/+ common)

Connector Pin Configuration  
Top View

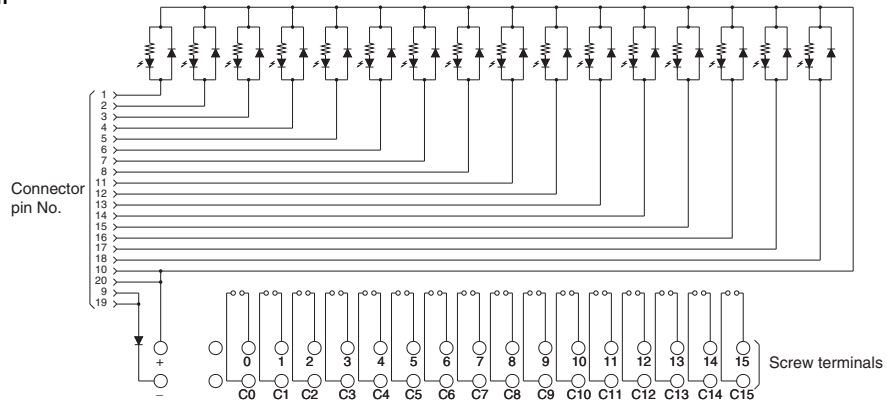
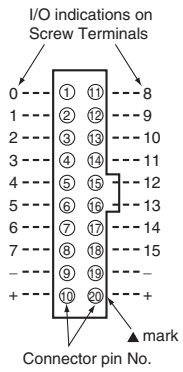

**P7TF-OS16-1**  
(PNP output/- common)

Connector Pin Configuration  
Top View

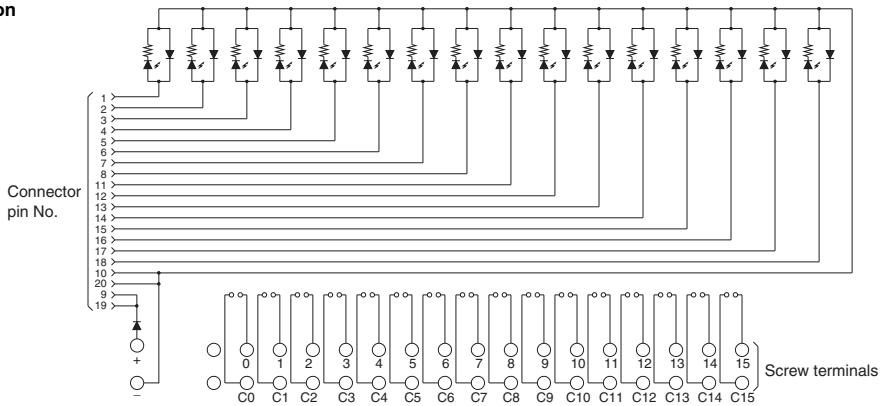
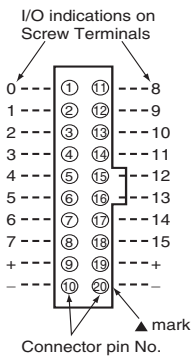

**P7TF-OS08**  
(NPN output/+ common)

Connector Pin Configuration  
Top View

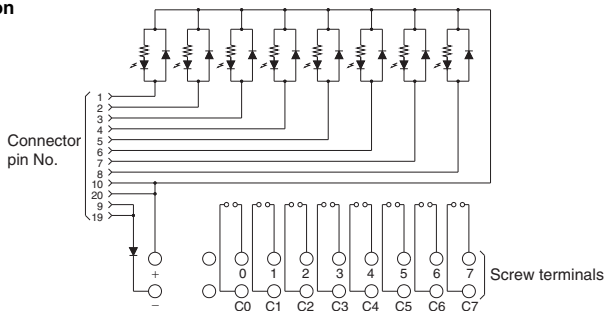
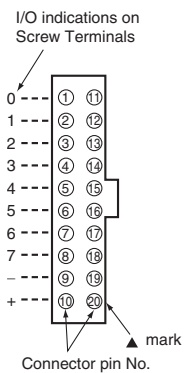

**Note:** Pin numbers are indicated for convenience. The ▲ mark can be used to determine orientation.

Dimensions

(Unit: mm)

I/O Terminal Sockets

P7TF-IS16

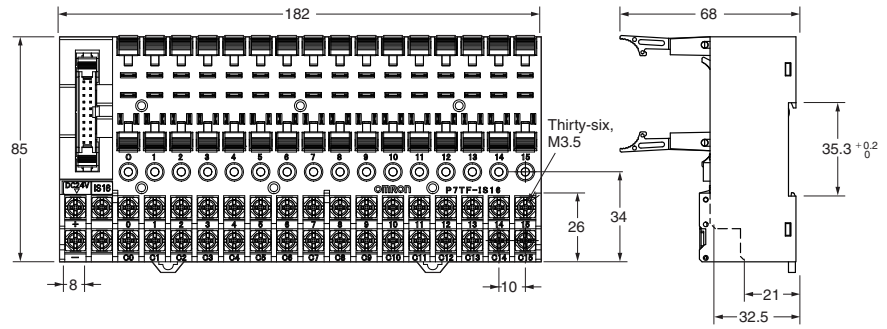
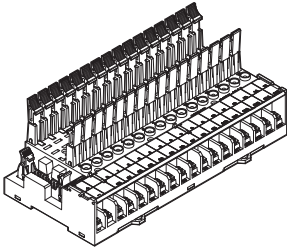

P7TF-OS16  
P7TF-OS16-1

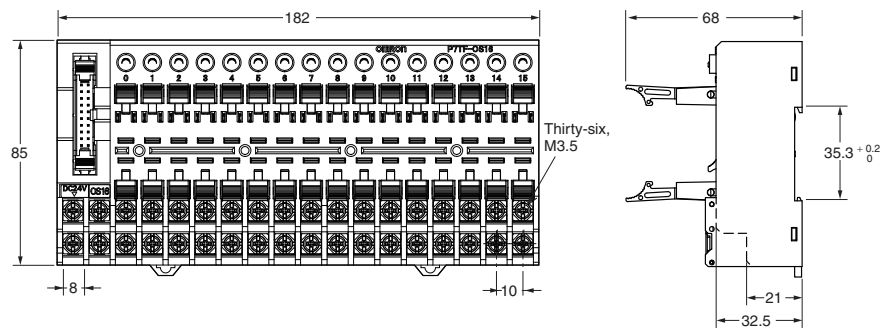
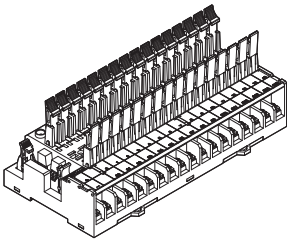

P7TF-OS08

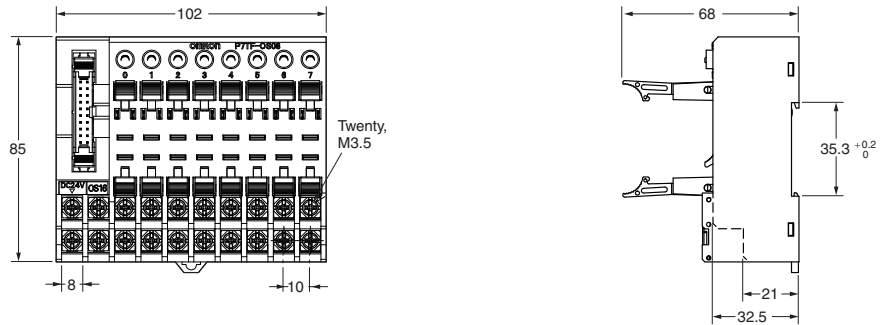
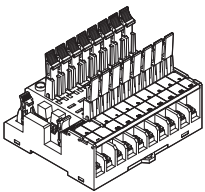

## Accessories (Order Separately)

### Shorting Bar

#### G78-04

Use this piece for short-circuiting across terminals.  
Max. current flow: 20 A

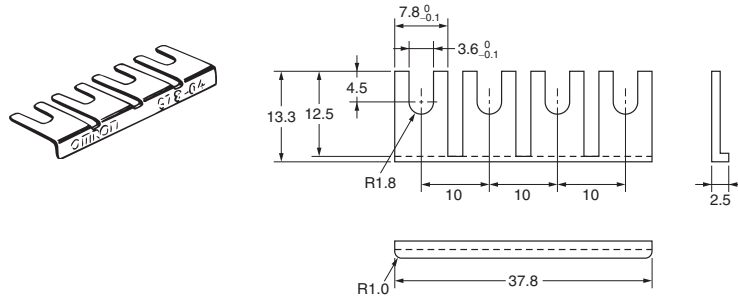

### Output Short-Circuit Module

#### G77-S

The output of the I/O Relay Terminal can be obtained without relays through the G77-S Output Short-Circuit Module. Refer to *Connection Example for SPDT Relays* on page 7 for details. Note that the G77-S Output Short-Circuit Module is not available for inputs.

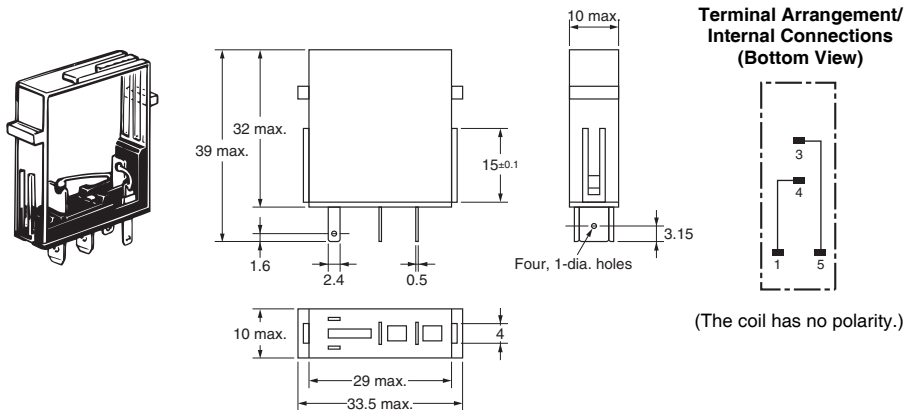

### Sockets (Can be used for G7T models with SPST-NO, SPST-NC, or SPDT specifications or G3TA models.)

#### P7TF-05

Can be used for sequences that use Slim Relays and for applications that develop to SPDT contacts on I/O Relay Terminals. To use SPDT on the P7TF I/O Terminal Socket, insert an Output Short-Circuit Module on the I/O Terminal, and combine the Block Base with an SPDT Relay on the output from the Output Short-Circuit Module.

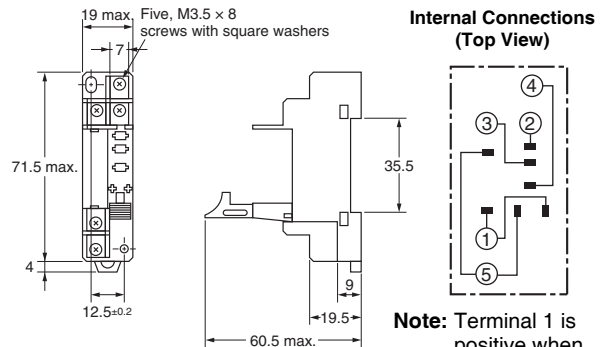
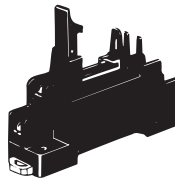

#### Specifications

<b>Contact resistance *</b>	10 mΩ max.
<b>Dielectric strength</b>	2,000 VAC for 1 minute
<b>Insulation resistance</b>	1,000 MΩ min. (at 500 VDC)
<b>Vibration resistance</b>	10 to 55 to 10 Hz with 0.5-mm single amplitude (1.0-mm double amplitude)
<b>Shock resistance</b>	1,000m/s <sup>2</sup>
<b>Ambient operating temperature</b>	-40 to 70°C (with no icing or condensation)
<b>Ambient operating humidity</b>	5% to 85%
<b>Weight</b>	Approx. 28 g

\* Measurement conditions: 1 A at 5 VDC using the voltage drop method

#### Mounting Hole Dimensions

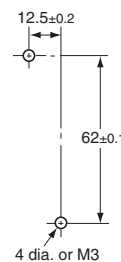

**Note:** Terminal 1 is positive when the G3TA or Indicator Module is employed.

### Indicator Module (with Surge Suppressing Function)

#### P70□

Remove the transparent style strip of the P7TF-05 socket and mount this module and it will function as an operation indicator with the surge suppression.

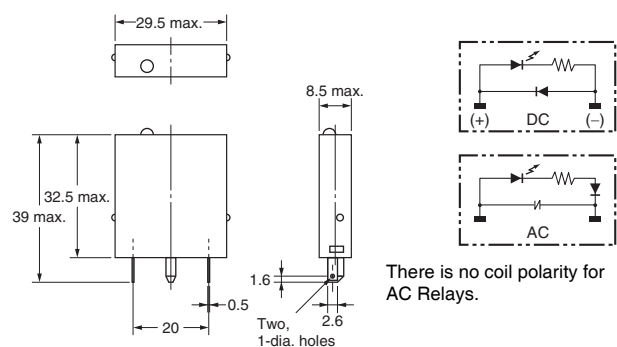
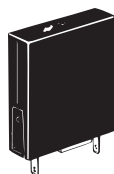

## Connection Example for SPDT Relays

The following is an application example for the P7TF-05 using an SPDT Relay on a terminal of the P7TF-OS16/OS08.

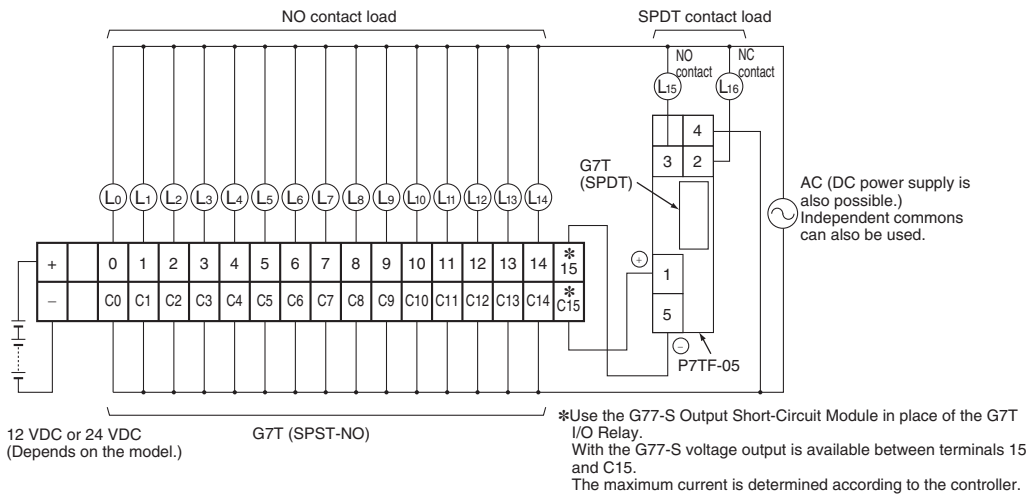

**Note:** If more than one G77-S Output Short-Circuit Module is employed, the voltage output of the terminals on the P7TF is as follows:  
 P7TF-OS16: The positive side (the lower row) connects to the common line internally.  
 P7TF-OS16-1: The negative side (the upper row) connects to the common line internally.

## Safety Precautions

Be sure to read the *Common Precautions for I/O Relay Terminal* in the website at the following URL: <http://www.ia.omron.com/>.

### Warning Indications

<b>Precautions for Correct Use</b>	<b>Supplementary comments on what to do or avoid doing, to prevent failure to operate, malfunction or undesirable effects on product performance.</b>
------------------------------------	---

### Precautions for Correct Use

#### General

I/O Relays and I/O Relay Terminal can be combined as follows to from I/O Relay Terminal:

		I/O Terminal Socket *	Replaceable Relay		
			I/O Relay	I/O SSR	
For outputs	DC	P7TF-OS16 P7TF-OS16-1 P7TF-OS08	G7T-1112S (SPST-NO type) G7T-1012S (SPST-NC type)	AC	G3TA-OA202SZ G3TA-OA202SL
				DC	G3TA-ODX02S G3TA-OD201S
For inputs	DC	P7TF-IS16 (DC)	G7T-1122S	DC	G3TA-IDZR02S(M)
	AC	P7TF-IS16 (AC)		AC	G3TA-IAZR02S

\* Relays are not mounted to the P7TF I/O Terminal Socket. Mount I/O Relays or I/O SSRs to the sockets. Specify the rated voltage in the same way as when ordering the P7TF I/O Terminal Socket.

- Combinations of AC Input Relays/SSRs and DC Input Relays/SSRs cannot be used with the same I/O Terminal Socket. This is because specifications for coil surge absorption elements are different.  
Relays/SSRs with different voltage specifications cannot be used with the same I/O Terminal Socket. (For example, a 100-VAC Input Relay/SSR and a 200-VAC Input Relay/SSR, or a 12-VDC Output Relay/SSR and a 24-VDC Output Relay cannot be used with the same I/O Terminal Socket.)  
This is because specifications of operation indicator circuits are different.
- Only use I/O Terminal Sockets, I/O Relays, and I/O SSRs with the same specifications for rated voltage.
- I/O Terminal Socket are color coded, as shown below, according to input/output and AC/DC specifications.

		I/O terminal label	I/O terminal indicators	I/O Relay case
For outputs	DC	Yellow	Green	Transparent
	DC	Red	Green	Green
For inputs	AC	Red	Red	Red

- Indicators indicate the presence or absence of signals.  
Use the display lever inside each relay for fault diagnosis. (Some relays do not have this lever depending on the specifications.)
- Each relay must be pressed down until its hold-down hooks engage completely. Heating or malfunction can result if relays are not mounted properly.
- Unlabeled terminals are not electrically connected. Use these for repeater terminals.
- Indicator positions and relay orientation differ between Input and Output I/O Terminal Socket. This is to aid in differentiating Input I/O Terminal Sockets from Output Terminal Sockets and in following signal flow.
- DC Input I/O Terminal Sockets and Output I/O Terminal Sockets with G3TA-OD□□□□ have positive and negative terminals, with the positive terminals normally being on the top of the I/O Relay Terminal Socket. Reversing positive and negative terminals will prevent operation.
- DIN tracks are generally used to mount I/O Relay Terminal. For screw mounting, a 210-mm DIN track is available that can be used as an adapter in combination with End Plates (PFP-M, two required).

- A Shorting Bar is provided to connect four terminals. The current capacity of the shorting bar is 20 A. As long as this current capacity is not exceeded, the shorting bar can be used in combination as shown below to connect more than four terminals.

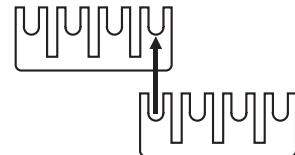

- Special Connecting Cables are provided for connections to OMRON SYSMAC PLC I/O Units with Connectors. Connecting Cables with two connectors, however, come in two types: Cables for Input Blocks (XW2Z-RI) and Cables for Output Blocks (XW2Z-RO).  
Be sure to purchase the correct Cable for the application.

#### Microload Switching

- Input Relays (DC coil type) and I/O SSRs (DC input type) can be mounted onto an Output I/O Terminal Socket.

## Terms and Conditions Agreement

### Read and understand this catalog.

Please read and understand this catalog before purchasing the products. Please consult your OMRON representative if you have any questions or comments.

### Warranties.

(a) Exclusive Warranty. Omron's exclusive warranty is that the Products will be free from defects in materials and workmanship for a period of twelve months from the date of sale by Omron (or such other period expressed in writing by Omron). Omron disclaims all other warranties, express or implied.

(b) Limitations. OMRON MAKES NO WARRANTY OR REPRESENTATION, EXPRESS OR IMPLIED, ABOUT NON-INFRINGEMENT, MERCHANTABILITY OR FITNESS FOR A PARTICULAR PURPOSE OF THE PRODUCTS. BUYER ACKNOWLEDGES THAT IT ALONE HAS DETERMINED THAT THE PRODUCTS WILL SUITABLY MEET THE REQUIREMENTS OF THEIR INTENDED USE.

Omron further disclaims all warranties and responsibility of any type for claims or expenses based on infringement by the Products or otherwise of any intellectual property right. (c) Buyer Remedy. Omron's sole obligation hereunder shall be, at Omron's election, to (i) replace (in the form originally shipped with Buyer responsible for labor charges for removal or replacement thereof) the non-complying Product, (ii) repair the non-complying Product, or (iii) repay or credit Buyer an amount equal to the purchase price of the non-complying Product; provided that in no event shall Omron be responsible for warranty, repair, indemnity or any other claims or expenses regarding the Products unless Omron's analysis confirms that the Products were properly handled, stored, installed and maintained and not subject to contamination, abuse, misuse or inappropriate modification. Return of any Products by Buyer must be approved in writing by Omron before shipment. Omron Companies shall not be liable for the suitability or unsuitability or the results from the use of Products in combination with any electrical or electronic components, circuits, system assemblies or any other materials or substances or environments. Any advice, recommendations or information given orally or in writing, are not to be construed as an amendment or addition to the above warranty.

See <http://www.omron.com/global/> or contact your Omron representative for published information.

### Limitation on Liability: Etc.

OMRON COMPANIES SHALL NOT BE LIABLE FOR SPECIAL, INDIRECT, INCIDENTAL, OR CONSEQUENTIAL DAMAGES, LOSS OF PROFITS OR PRODUCTION OR COMMERCIAL LOSS IN ANY WAY CONNECTED WITH THE PRODUCTS, WHETHER SUCH CLAIM IS BASED IN CONTRACT, WARRANTY, NEGLIGENCE OR STRICT LIABILITY.

Further, in no event shall liability of Omron Companies exceed the individual price of the Product on which liability is asserted.

### Suitability of Use.

Omron Companies shall not be responsible for conformity with any standards, codes or regulations which apply to the combination of the Product in the Buyer's application or use of the Product. At Buyer's request, Omron will provide applicable third party certification documents identifying ratings and limitations of use which apply to the Product. This information by itself is not sufficient for a complete determination of the suitability of the Product in combination with the end product, machine, system, or other application or use. Buyer shall be solely responsible for determining appropriateness of the particular Product with respect to Buyer's application, product or system. Buyer shall take application responsibility in all cases.

NEVER USE THE PRODUCT FOR AN APPLICATION INVOLVING SERIOUS RISK TO LIFE OR PROPERTY OR IN LARGE QUANTITIES WITHOUT ENSURING THAT THE SYSTEM AS A WHOLE HAS BEEN DESIGNED TO ADDRESS THE RISKS, AND THAT THE OMRON PRODUCT(S) IS PROPERLY RATED AND INSTALLED FOR THE INTENDED USE WITHIN THE OVERALL EQUIPMENT OR SYSTEM.

### Programmable Products.

Omron Companies shall not be responsible for the user's programming of a programmable Product, or any consequence thereof.

### Performance Data.

Data presented in Omron Company websites, catalogs and other materials is provided as a guide for the user in determining suitability and does not constitute a warranty. It may represent the result of Omron's test conditions, and the user must correlate it to actual application requirements. Actual performance is subject to the Omron's Warranty and Limitations of Liability.

### Change in Specifications.

Product specifications and accessories may be changed at any time based on improvements and other reasons. It is our practice to change part numbers when published ratings or features are changed, or when significant construction changes are made. However, some specifications of the Product may be changed without any notice. When in doubt, special part numbers may be assigned to fix or establish key specifications for your application. Please consult with your Omron's representative at any time to confirm actual specifications of purchased Product.

### Errors and Omissions.

Information presented by Omron Companies has been checked and is believed to be accurate; however, no responsibility is assumed for clerical, typographical or proofreading errors or omissions.