

MECHATROLINK-II Communications Reference SERVOPACKs

SGDV-□□□E11 (For Rotary Servomotors)



Model Designations

Σ-V Series
SGDV
SERVOPACKs
with DC Power Input
1st+2nd+3rd digits
4th digit
5th+6th digits
7th digit
8th+9th+10th digits
11th+12th digits
13th digit

S G D V - 2R9 E 11 A 002 00 0

1st+2nd+3rd digits Current

| Voltage | Code | Applicable Servomotor Max. Capacity kW |
|---------|------|--|
| 24 VDC/ | 1R7 | 0.011 |
| 48 VDC | 2R9 | 0.030 |

4th digit Power Supply Voltage

| Code | Specifications |
|------|----------------|
| E | 48 VDC* |

5th+6th digits Interface

| Code | Specifications |
|------|---|
| 11 | MECHATROLINK-II communications Reference (for rotary servomotors) |

7th digit Design Revision Order

A, B...

8th+9th+10th digits Options (hardware)

| Code | Specifications |
|------|---------------------------------|
| 002 | Base-mounted, varnish(standard) |

11th+12th digits Options (software)

| Code | Specifications |
|------|----------------|
| 00 | Standard |

13th digit Options (parameter)

| Code | Specifications |
|------|----------------|
| 0 | Standard |

*: Either a 24-VDC or a 48-VDC power supply can be used for the main circuit. The control power supply must be 24 VDC.
Note: If the option codes digits 8 to 13 are all zeros, they are omitted.

Features

● Real-time communications

MECHATROLINK-II communications enable high-speed control for 30 stations at a maximum transmission speed of 10 Mbps in a transmission cycle from 250 μ s to 4 ms (set by the host controller). Such a high transmission speed allows real-time transmission of various data required for control.

● Cost savings

Thirty stations can be connected to a single MECHATROLINK-II transmission line, so wiring costs and time are greatly reduced. Also, only one signal connector is required on the host controller. And, the all-digital network eliminates the need for conversion from digital to analog for speed/torque references and for a pulse generator to generate position references.

● High-precision motion control

The SGD V SERVOPACK when connected to the host controller in the MECHATROLINK-II network provides not only torque, position, and speed control but also synchronized phase control that requires advanced control technology. The control mode can be changed online so that the machine can move smoothly in complex motions with great efficiency.

Ratings

| SERVOPACK Model SGD V-□□□□ | 1R7E | | 2R9E | |
|--|------------------|------------------|------------------|------------------|
| Applicable Servomotor Max. Capacity kW | 0.011 | | 0.030 | |
| Continuous Output Current Arms | 1.7 | | 2.9 | |
| Max. Output Current Arms | 4.1 | | 8.6 | |
| Regenerative Resistors | None | | | |
| Main Circuit* | 24 VDC \pm 15% | 48 VDC \pm 15% | 24 VDC \pm 15% | 48 VDC \pm 15% |
| Control Circuit | 24 VDC \pm 15% | | | |

*: Either a 24-VDC or a 48-VDC power supply can be used for the main circuit. When a 24-VDC power supply is used, the torque-motor speed characteristics for a 48 VDC cannot be achieved. For details, refer to Torque-Motor Speed Characteristics on page 6.

● SERVOPACK Overload Characteristics

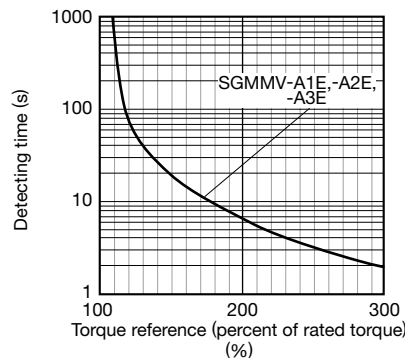
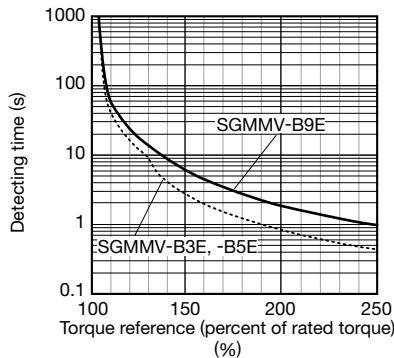

Note: Overload characteristics shown above do not guarantee continuous duty of 100% or more output. Use a servomotor with effective torque within the continuous duty zone of Torque-Motor Speed Characteristics.

Specifications

| Items | | Specifications | | |
|---|---|--|---|---|
| Control Method | | PWM control, sine-wave driven | | |
| Feedback | | Serial encoder: 17-bit (incremental/absolute) | | |
| Operating Conditions | Ambient Temperature | 0 to +55°C | | |
| | Storage Temperature | -20 to +85°C | | |
| | Ambient Humidity | 90%RH or less | With no freezing or condensation | |
| | Storage Humidity | 90%RH or less | | |
| | Vibration Resistance | 4.9 m/s ² | | |
| | Shock Resistance | 19.6 m/s ² | | |
| | Protection Class | IP10 | An environment that satisfies the following conditions. <ul style="list-style-type: none"> • Free of corrosive or flammable gases • Free of exposure to water, oil, or chemicals • Free of dust, salts, or iron dust | |
| | Pollution Degree | 2 | | |
| | Altitude | 1000 m or less | | |
| Others | Do not use SERVOPACKs in the following locations: <ul style="list-style-type: none"> • Locations subject to static electricity noise, strong electromagnetic/magnetic fields, radioactivity | | | |
| Applicable Standards | | UL508C EN55011/A1, EN61000-6-2, EN61800-3, EN61800-5-1 | | |
| Mounting | | Base-mounted | | |
| Performance | Speed Control Range | | 1 : 5000 (The lower limit of the speed control range must be lower than the point at which the rated torque does not cause the servomotor to stop.) | |
| | Speed Regulation ^{*1} | Load Fluctuation | 0% to 100% load: ±0.01% max. (at rated speed) | |
| | | Voltage Fluctuation | Rated voltage: ±10% : 0% (at rated speed) | |
| | | Temperature Fluctuation | 25±25°C : ±0.1% max. (at rated speed) | |
| | Torque Control Tolerance (Repeatability) | | ±1% | |
| Soft Start Time Setting ^{*2} | | 0 to 10 s (can be set individually for acceleration and deceleration.) | | |
| I/O Signal | Sequence Input | Input Signals which can be allocated | Number of Channels | 3 channels |
| | | | Functions | <ul style="list-style-type: none"> • Homing deceleration switch signal (/DEC) • External latch signals (/EXT 1) • Forward run prohibited (P-OT), reverse run prohibited (N-OT) • Forward external torque limit (/P-CL), reverse external torque limit (/N-CL) Positive and negative logic can be changed. |
| | Sequence Output | Output Signals which can be allocated | Fixed Output | Servo alarm (ALM) |
| | | | Number of Channels | 3 channels |
| | | Functions | <ul style="list-style-type: none"> • Positioning completion (/COIN) • Speed limit detection (/VLT) • Speed coincidence detection (/V-CMP) • Brake (/BK) • Rotation detection (/TGON) • Warning (/WARN) • Servo ready (/S-RDY) • Near (/NEAR) • Torque limit detection (/CLT) Positive and negative logic can be changed. | |
| Communications | Computer (USB) | Compatible with SigmaWin+. Compliant with the USB1.1 standard (12 Mbps) | | |
| Display | | Servo alarm (ALM): red; servo ready (RDY): green; communications(COM): green | | |
| DIP Switches for MECHATROLINK-II Communication Settings | | DIP switches: SW1 and SW2 | Number of poles: 4/DIP switch (two DIP switches)*3 | |
| Analog Monitor | | Number of points: 2 Output voltage: ±10 VDC (linearity effective range: ±8 V) Output through the analog monitor unit (model: JUSP-PC001-E) | | |

*1: Speed regulation is defined as follows:

$$\text{Speed regulation} = \frac{\text{No-load motor speed} - \text{Total load motor speed}}{\text{Rated motor speed}} \times 100\%$$

The motor speed may change due to voltage fluctuation or temperature fluctuation.

The ratio of speed changes to the rated speed represent speed regulation due to voltage and temperature fluctuations.

*2 : For information on soft start, refer to 4.2.10 Velocity Control (VELCTRL: 3CH) in the AC Servo Drives Σ -V Series USER'S MANUAL MECHATROLINK-II Commands

*3 : For details, refer to 4.1.1 Setting Switches SW1 and SW2 in the AC Servo Drives DC Power Input Σ -V Series USER'S MANUAL Design and Maintenance

(Cont'd)

Specifications

| Items | Specifications | |
|--------------------------------|--|---|
| Dynamic Brake (DB) | Not available | |
| Regenerative Processing | Not available | |
| Overtravelling (OT) Prevention | Decelerate to a stop or coast to a stop when overtraveling is detected and an overtravel signal (P-OT or N-OT) is input. | |
| Protective Functions | Overcurrent, Overvoltage, low voltage, overload, etc. | |
| Utility Functions | Gain adjustment, alarm history, JOG operation, origin search, etc. | |
| MECHATROLINK-II Communications | Communications Protocol | MECHATROLINK-II |
| | Station Address | 41H to 5FH (max. number of slaves: 30) Set station addresses with combinations of SW1 and SW2 settings. |
| | Transmission Speed | 10 Mbps, 4 Mbps Set by using the SW2 DIP switch. |
| | Transmission Cycle | 250 μ s or 0.5 ms to 4.0 ms (increments of 0.5 ms) |
| | Number of Transmission Bytes | Can be switched between 17 bytes /station and 32 bytes / station. Set by using the SW2 DIP switch. |
| Command Method | Performance | Position control, speed control, and torque control through MECHATROLINK-II communications |
| | Command Input | MECHATROLINK-II commands (for sequence, motion, data setting/reference, monitoring, adjustment, and other commands.) |

Power Supply Capacities and Power Losses

The following table shows SERVOPACK's power supply capacities and power losses at the rated output.

| Main Circuit Power Supply | Applicable Servomotor Max. Capacity W | SERVOPACK Model SGDV- | Main Circuit Power Supply Capacity per SERVOPACK W | Output Current Arms | Main Circuit Power Loss W | Regenerative Resistor Power Loss W | Control Circuit Power Loss W | Total Power Loss W |
|---------------------------|--|--------------------------|---|------------------------|------------------------------|---------------------------------------|---------------------------------|-----------------------|
| 24 VDC | 11 | 1R7E | 108 | 1.7 | 3.4 | - | 7.2 | 10.6 |
| | 30 | 2R9E | 165 | 2.9 | 6.9 | | | 14.1 |
| 48 VDC | 11 | 1R7E | 169 | 1.7 | 3.4 | - | 7.2 | 10.6 |
| | 30 | 2R9E | 411 | 2.9 | 6.9 | | | 14.1 |

Note: These power supply capacities are net values at instantaneous maximum loads.

Selecting Cables

- Cables for **CN1** **CN3** **CN5** **CN6** **CN7** (MECHATROLINK-II Communications Reference SERVOPACKs)

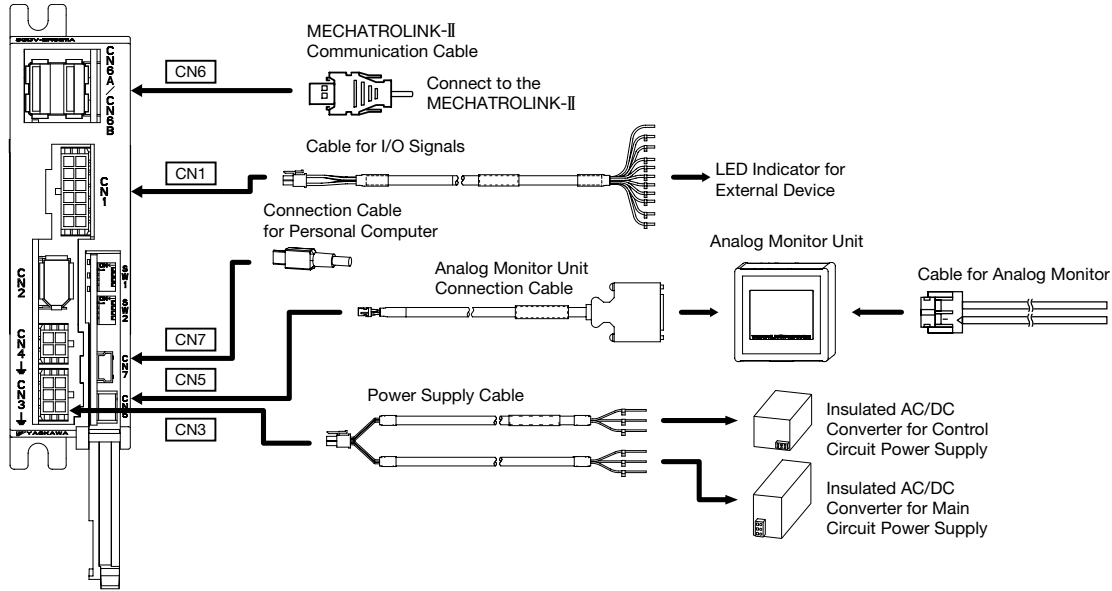

| Name | Length | Order No. | Specifications | Details | |
|--|---|------------------|------------------|---------|-----|
| CN1 Cables for I/O Signals | 1 m | JZSP-CF1I02-1-E | | (1) | |
| | 2 m | JZSP-CF1I02-2-E | | | |
| | 3 m | JZSP-CF1I02-3-E | | | |
| CN3 Power Supply Cables | 1 m | JZSP-CF1G00-01-E | | (2) | |
| | 2 m | JZSP-CF1G00-02-E | | | |
| | 3 m | JZSP-CF1G00-03-E | | | |
| | 4 m | JZSP-CF1G00-04-E | | | |
| | 5 m | JZSP-CF1G00-05-E | | | |
| | 6 m | JZSP-CF1G00-06-E | | | |
| | 7 m | JZSP-CF1G00-07-E | | | |
| | 8 m | JZSP-CF1G00-08-E | | | |
| | 9 m | JZSP-CF1G00-09-E | | | |
| | 10 m | JZSP-CF1G00-10-E | | | |
| CN5 Analog Monitor Unit Cable | Analog Monitor Unit | | | (3) | |
| | Analog Monitor Unit Connection Cable | 0.3 m | JZSP-CF1S06-A3-E | | (4) |
| | Cables for Analog Monitor | 1 m | JZSP-CA01-E | | (5) |
| CN6A CN6B MECHATROLINK-II Communication Cable | Cables with Connectors at Both Ends | 0.5 to 50 m | JEPMC-W6002-□□-E | | (6) |
| | Cables with Connectors at Both Ends (with Ferrite Core) | 0.5 to 50 m | JEPMC-W6003-□□-E | | (7) |
| | Terminator | | JEPMC-W6022-E | | (8) |
| CN7 Connection Cables for Personal Computer | 2.5 m | JZSP-CVS06-02-E | | (9) | |

DC

MECHATROLINK-II Type SERVOPACKS

Selecting Cables

(1) Cable with Loose Wires at One End for CN1

(Model: JZSP-CF1102-□-E)

- External Dimensions (Units: mm)

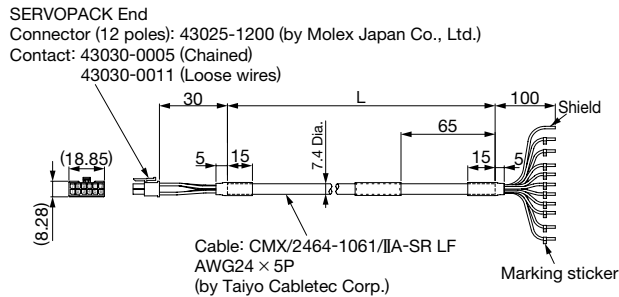

| Model | Cable Length |
|-----------------|--------------|
| JZSP-CF1102-1-E | 1 m |
| JZSP-CF1102-2-E | 2 m |
| JZSP-CF1102-3-E | 3 m |

● Cable with Loose Wires at One End for CN1

Connection Diagram of JZSP-CF1102-□-E Cable

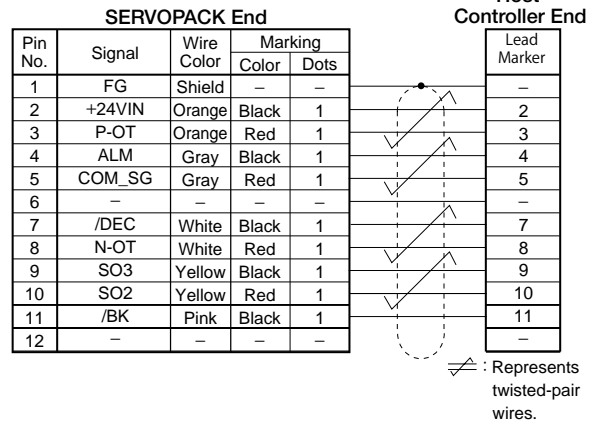

(2) Cable with Loose Wires at One End for CN3

(Model: JZSP-CF1G00-□□-E)

- External Dimensions (Units: mm)

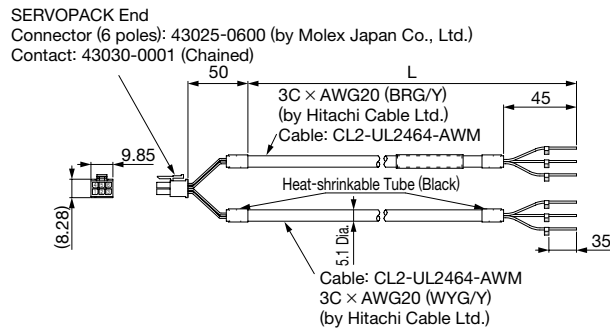

| Model | Cable Length |
|------------------|--------------|
| JZSP-CF1G00-01-E | 1 m |
| JZSP-CF1G00-02-E | 2 m |
| JZSP-CF1G00-03-E | 3 m |
| JZSP-CF1G00-04-E | 4 m |
| JZSP-CF1G00-05-E | 5 m |
| JZSP-CF1G00-06-E | 6 m |
| JZSP-CF1G00-07-E | 7 m |
| JZSP-CF1G00-08-E | 8 m |
| JZSP-CF1G00-09-E | 9 m |
| JZSP-CF1G00-10-E | 10 m |

• Specifications

| Pin No. | Cable Color | Signal |
|---------|--------------|--------|
| 1 | Green/yellow | FG |
| 2 | Green/yellow | FG |
| 3 | Blue | L2 |
| 4 | White | C2 |
| 5 | Yellow | C1 |
| 6 | Red | L1 |

Selecting Cables

(3) Analog Monitor Unit

(Model: JUSP-PC001-E)

- External Dimensions (Units: mm)

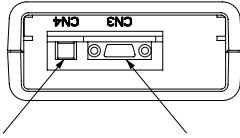

CN4: Connector for Analog Monitor CN3: Connector for Digital Operator

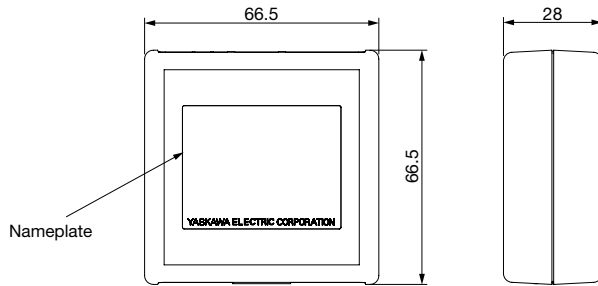

CN1: Connector for SERVOPACK

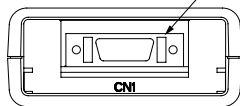

Note: The cable (JZSP-CF1S06-A3-E) to connect the SERVOPACK is not included.

(4) Analog Monitor Unit Connection Cable for CN5

(Model: JZSP-CF1S06-A3-E)

- External Dimensions (Units: mm)

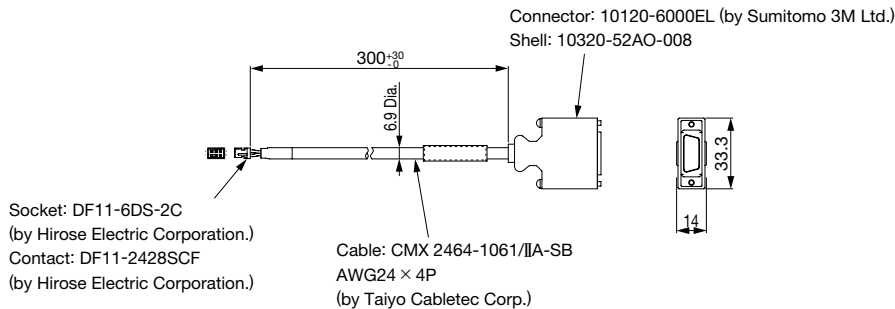

DC

MECHATROLINK-II Type SERVOPACKs

Selecting Cables

(5) Analog Monitor Unit Cable for CN4 (Model: JZSP-CA01-E)

- External Dimensions (Units: mm)

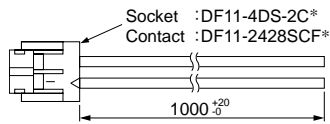

* : Manufactured by Hirose Electric Corporation.

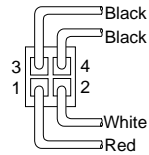

View from Cable End

- Specifications

| Pin No. | Cable Color | Signal | Standard Settings |
|---------|---------------------|------------------|---|
| 1 | Red | Analog Monitor 2 | Motor speed : 1V/1000 min-1 |
| 2 | White | Analog Monitor 1 | Torque reference : 1V/100% rated torque |
| 3, 4 | Black (2 cables) | GND (0V) | - |

Note : The specifications above are factory settings. Monitor specifications can be changed by changing parameters Pn006 and Pn007.

(6) Cable with Connectors at Both Ends for CN6

(Model: JEPMC-W6002-□□-E)

- External Dimensions (Units: mm)

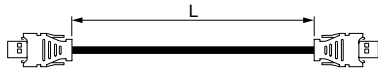

| Model | Cable Length (L) |
|------------------|------------------|
| JEPMC-W6002-A5-E | 0.5 m |
| JEPMC-W6002-01-E | 1.0 m |
| JEPMC-W6002-03-E | 3.0 m |
| JEPMC-W6002-05-E | 5.0 m |
| JEPMC-W6002-10-E | 10.0 m |
| JEPMC-W6002-20-E | 20.0 m |
| JEPMC-W6002-30-E | 30.0 m |
| JEPMC-W6002-40-E | 40.0 m |
| JEPMC-W6002-50-E | 50.0 m |

(7) Cable with Connectors at Both Ends (with Ferrite Core) for CN6

(Model: JEPMC-W6003-□□-E)

- External Dimensions (Units: mm)

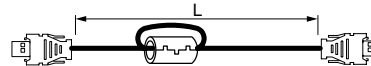

| Model | Cable Length (L) |
|------------------|------------------|
| JEPMC-W6003-A5-E | 0.5 m |
| JEPMC-W6003-01-E | 1.0 m |
| JEPMC-W6003-03-E | 3.0 m |
| JEPMC-W6003-05-E | 5.0 m |
| JEPMC-W6003-10-E | 10.0 m |
| JEPMC-W6003-20-E | 20.0 m |
| JEPMC-W6003-30-E | 30.0 m |
| JEPMC-W6003-40-E | 40.0 m |
| JEPMC-W6003-50-E | 50.0 m |

IMPORTANT Use a MECHATROLINK-II communications cable specified by Yaskawa. When using other cables, noise resistance may be reduced, and operation cannot be guaranteed.

(8) MECHATROLINK-II Terminator for CN6 (Model : JEPMC-W6022-E)

- External Dimensions (Units: mm)

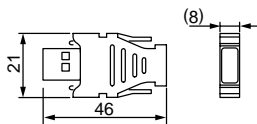

Selecting Cables

(9) Connection Cable for Personal Computer for CN7
(Model: JZSP-CVS06-02-E)

- External Dimensions (Units: mm)

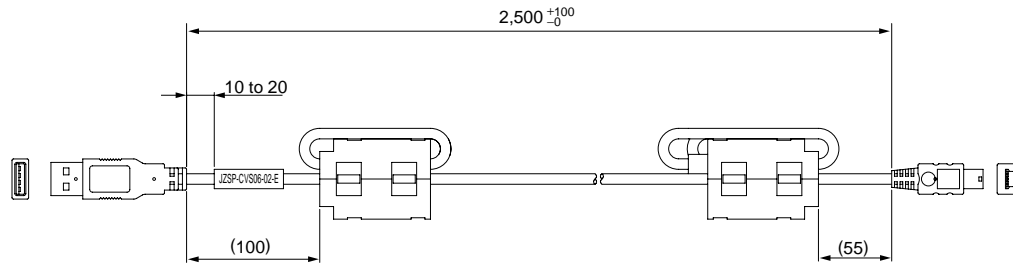

IMPORTANT Use a cable specified by Yaskawa.
When using other cables, operation cannot be guaranteed.