

# DATA SHEET

## **PDTA123E series**

**PNP resistor-equipped transistors;**

**R1 = 2.2 k $\Omega$ , R2 = 2.2 k $\Omega$**

Product specification  
Supersedes data of 2004 Apr 07

2004 Aug 02

## PNP resistor-equipped transistors; R1 = 2.2 k $\Omega$ , R2 = 2.2 k $\Omega$

## PDTA123E series

### FEATURES

- Built-in bias resistors
- Simplified circuit design
- Reduction of component count
- Reduced pick and place costs.

### APPLICATIONS

- General purpose switching and amplification
- Inverter and interface circuits
- Circuit driver.

### QUICK REFERENCE DATA

| SYMBOL           | PARAMETER                 | TYP. | MAX. | UNIT       |
|------------------|---------------------------|------|------|------------|
| V <sub>CEO</sub> | collector-emitter voltage | –    | –50  | V          |
| I <sub>O</sub>   | output current (DC)       | –    | –100 | mA         |
| R1               | bias resistor             | 2.2  | –    | k $\Omega$ |
| R2               | bias resistor             | 2.2  | –    | k $\Omega$ |

### DESCRIPTION

PNP resistor-equipped transistor (see “Simplified outline, symbol and pinning” for package details).

### PRODUCT OVERVIEW

| TYPE NUMBER | PACKAGE       |        | MARKING CODE       | NPN COMPLEMENT |
|-------------|---------------|--------|--------------------|----------------|
|             | PHILIPS       | EIAJ   |                    |                |
| PDTA123EE   | SOT416        | SC-75  | 5C                 | PDTC123EE      |
| PDTA123EEF  | SOT490        | SC-89  | 6C                 | PDTC123EEF     |
| PDTA123EK   | SOT346        | SC-59  | 42                 | PDTC123EK      |
| PDTA123EM   | SOT883        | SC-101 | F7                 | PDTC123EM      |
| PDTA123ES   | SOT54 (TO-92) | SC-43  | TA123E             | PDTC123ES      |
| PDTA123ET   | SOT23         | –      | *21 <sup>(1)</sup> | PDTC123ET      |
| PDTA123EU   | SOT323        | SC-70  | *42 <sup>(1)</sup> | PDTC123EU      |

### Note

1. \* = p: Made in Hong Kong.  
\* = t: Made in Malaysia.  
\* = W: Made in China.

PNP resistor-equipped transistors;  
 R1 = 2.2 kΩ, R2 = 2.2 kΩ

PDTA123E series

SIMPLIFIED OUTLINE, SYMBOL AND PINNING

| TYPE NUMBER  | SIMPLIFIED OUTLINE AND SYMBOL | PINNING |             |
|--|-------------------------------|---------|-------------|
|  |                               | PIN     | DESCRIPTION |
| PDTA123ES  |                               | 1       | base        |
|  |                               | 2       | collector   |
|  |                               | 3       | emitter     |
| PDTA123EE<br>PDTA123EEF<br>PDTA123EK<br>PDTA123ET<br>PDTA123EU |                               | 1       | base        |
|  |                               | 2       | emitter     |
|  |                               | 3       | collector   |
| PDTA123EM  |                               | 1       | base        |
|  |                               | 2       | emitter     |
|  |                               | 3       | collector   |

PNP resistor-equipped transistors;  
R1 = 2.2 k $\Omega$ , R2 = 2.2 k $\Omega$

PDTA123E series

### ORDERING INFORMATION

| TYPE NUMBER | PACKAGE |  |         |
|-------------|---------|--|---------|
|             | NAME    | DESCRIPTION  | VERSION |
| PDTA123EE   | –       | plastic surface mounted package; 3 leads   | SOT416  |
| PDTA123EEF  | –       | plastic surface mounted package; 3 leads   | SOT490  |
| PDTA123EK   | –       | plastic surface mounted package; 3 leads   | SOT346  |
| PDTA123EM   | –       | leadless ultra small plastic package; 3 solder lands; body<br>1.0 x 0.6 x 0.5 mm | SOT883  |
| PDTA123ES   | –       | plastic single-ended leaded (through hole) package; 3 leads                      | SOT54   |
| PDTA123ET   | –       | plastic surface mounted package; 3 leads   | SOT23   |
| PDTA123EU   | –       | plastic surface mounted package; 3 leads   | SOT323  |

### LIMITING VALUES

In accordance with the Absolute Maximum Rating System (IEC 60134).

| SYMBOL           | PARAMETER                     | CONDITIONS               | MIN. | MAX. | UNIT |
|------------------|-------------------------------|--------------------------|------|------|------|
| V <sub>CB0</sub> | collector-base voltage        | open emitter             | –    | –50  | V    |
| V <sub>CEO</sub> | collector-emitter voltage     | open base                | –    | –50  | V    |
| V <sub>EBO</sub> | emitter-base voltage          | open collector           | –    | –10  | V    |
| V <sub>I</sub>   | input voltage                 |                          |      |      |      |
|                  | positive                      |                          | –    | +10  | V    |
|                  | negative                      |                          | –    | –12  | V    |
| I <sub>O</sub>   | output current (DC)           |                          | –    | –100 | mA   |
| I <sub>CM</sub>  | peak collector current        |                          | –    | –100 | mA   |
| P <sub>tot</sub> | total power dissipation       | T <sub>amb</sub> ≤ 25 °C |      |      |      |
|                  | SOT54                         | note 1                   | –    | 500  | mW   |
|                  | SOT23                         | note 1                   | –    | 250  | mW   |
|                  | SOT346                        | note 1                   | –    | 250  | mW   |
|                  | SOT323                        | note 1                   | –    | 200  | mW   |
|                  | SOT416                        | note 1                   | –    | 150  | mW   |
|                  | SOT490                        | notes 1 and 2            | –    | 250  | mW   |
| SOT883           | notes 2 and 3                 | –                        | 250  | mW   |      |
| T <sub>stg</sub> | storage temperature           |                          | –65  | +150 | °C   |
| T <sub>j</sub>   | junction temperature          |                          | –    | 150  | °C   |
| T <sub>amb</sub> | operating ambient temperature |                          | –65  | +150 | °C   |

### Notes

1. Refer to standard mounting conditions.
2. Reflow soldering is the only recommended soldering method.
3. Refer to SOT883 standard mounting conditions; FR4 with 60  $\mu$ m copper strip line.

PNP resistor-equipped transistors;  
R1 = 2.2 k $\Omega$ , R2 = 2.2 k $\Omega$

PDTA123E series

### THERMAL CHARACTERISTICS

| SYMBOL               | PARAMETER                                   | CONDITIONS               | VALUE | UNIT |
|----------------------|---|--------------------------|-------|------|
| R <sub>th(j-a)</sub> | thermal resistance from junction to ambient | T <sub>amb</sub> ≤ 25 °C |       |      |
|                      | SOT54                                       | note 1                   | 250   | K/W  |
|                      | SOT23                                       | note 1                   | 500   | K/W  |
|                      | SOT346                                      | note 1                   | 500   | K/W  |
|                      | SOT323                                      | note 1                   | 625   | K/W  |
|                      | SOT416                                      | note 1                   | 830   | K/W  |
|                      | SOT490                                      | notes 1 and 2            | 500   | K/W  |
| SOT883               | notes 2 and 3                               | 500                      | K/W   |      |

### Notes

1. Refer to standard mounting conditions.
2. Reflow soldering is the only recommended soldering method.
3. Refer to SOT883 standard mounting conditions; FR4 with 60  $\mu$ m copper strip line.

### CHARACTERISTICS

T<sub>amb</sub> = 25 °C unless otherwise specified.

| SYMBOL              | PARAMETER                            | CONDITIONS   | MIN. | TYP. | MAX. | UNIT       |
|---------------------|--------------------------------------|--|------|------|------|------------|
| I <sub>CBO</sub>    | collector-base cut-off current       | V <sub>CB</sub> = -50 V; I <sub>E</sub> = 0 A                                | -    | -    | -100 | nA         |
| I <sub>CEO</sub>    | collector-emitter cut-off current    | V <sub>CE</sub> = -30 V; I <sub>B</sub> = 0 A                                | -    | -    | -1   | $\mu$ A    |
|                     |                                      | V <sub>CE</sub> = -30 V; I <sub>B</sub> = 0 A; T <sub>j</sub> = 150 °C       | -    | -    | -50  | $\mu$ A    |
| I <sub>EBO</sub>    | emitter-base cut-off current         | V <sub>EB</sub> = -5 V; I <sub>C</sub> = 0 A                                 | -    | -    | -2   | mA         |
| h <sub>FE</sub>     | DC current gain                      | V <sub>CE</sub> = -5 V; I <sub>C</sub> = -20 mA                              | 30   | -    | -    |            |
| V <sub>CEsat</sub>  | collector-emitter saturation voltage | I <sub>C</sub> = -10 mA; I <sub>B</sub> = -0.5 mA                            | -    | -    | -150 | mV         |
| V <sub>i(off)</sub> | input-off voltage                    | I <sub>C</sub> = -1 mA; V <sub>CE</sub> = -5 V                               | -    | -1.2 | -0.5 | V          |
| V <sub>i(on)</sub>  | input-on voltage                     | I <sub>C</sub> = -20 mA; V <sub>CE</sub> = -0.3 V                            | -2   | -1.6 | -    | V          |
| R1                  | input resistor                       |  | 1.54 | 2.2  | 2.86 | k $\Omega$ |
| $\frac{R2}{R1}$     | resistor ratio                       |  | 0.8  | 1    | 1.2  |            |
| C <sub>c</sub>      | collector capacitance                | I <sub>E</sub> = i <sub>e</sub> = 0 A; V <sub>CB</sub> = -10 V;<br>f = 1 MHz | -    | -    | 3    | pF         |

PNP resistor-equipped transistors;  
R1 = 2.2 kΩ, R2 = 2.2 kΩ

PDTA123E series

PACKAGE OUTLINES

Plastic surface mounted package; 3 leads

SOT416

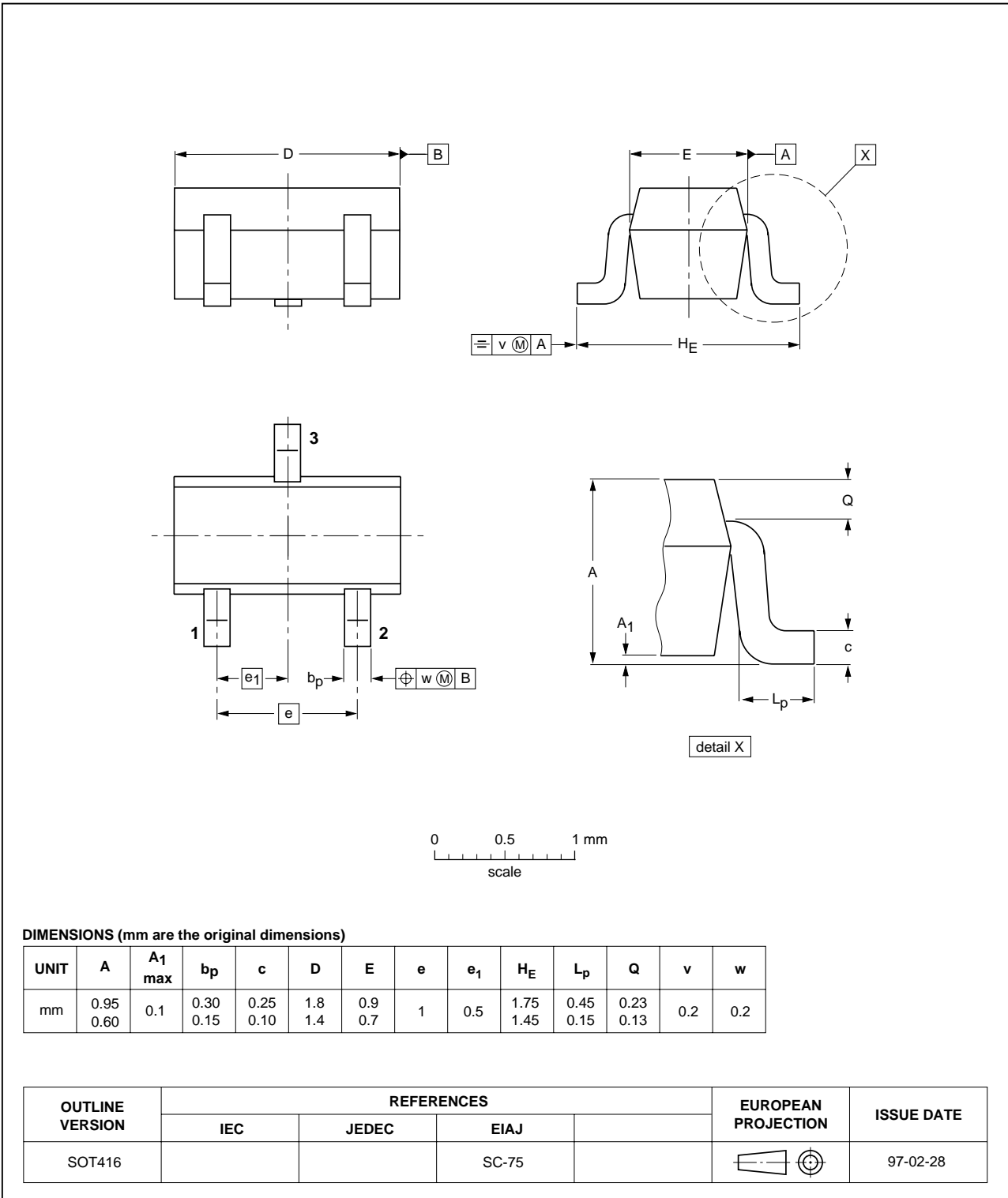

PNP resistor-equipped transistors;  
R1 = 2.2 kΩ, R2 = 2.2 kΩ

PDTA123E series

Plastic surface mounted package; 3 leads

SOT490

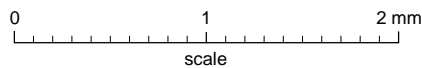
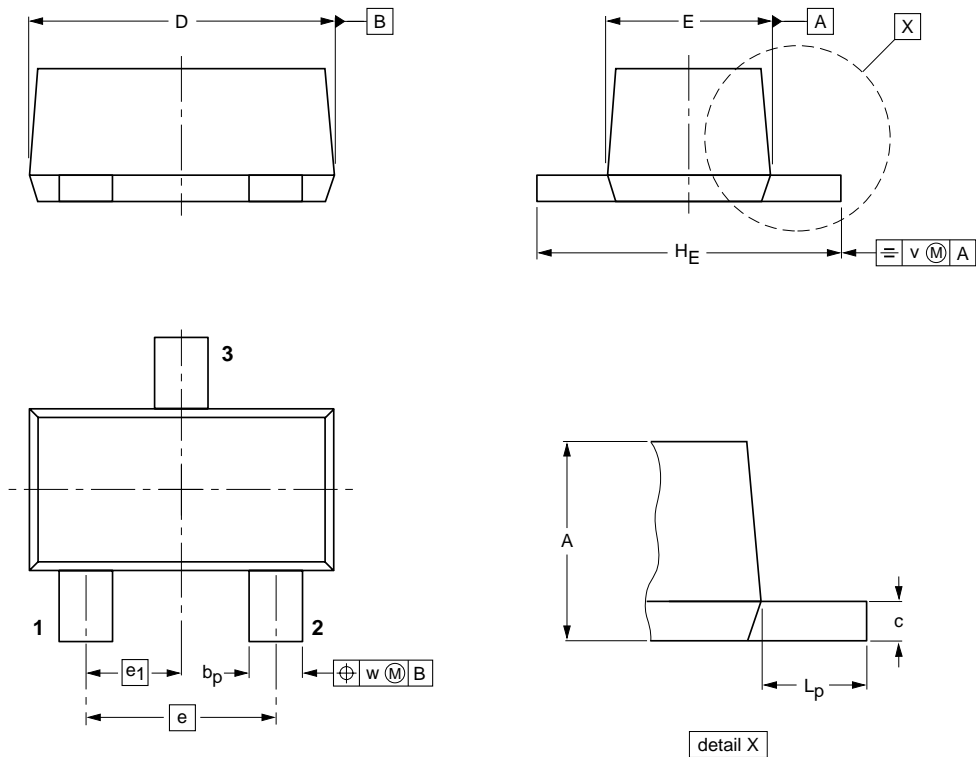

**DIMENSIONS (mm are the original dimensions)**

| UNIT | A          | b <sub>p</sub> | c          | D          | E            | e   | e <sub>1</sub> | H <sub>E</sub> | L <sub>p</sub> | v   | w   |
|------|------------|----------------|------------|------------|--------------|-----|----------------|----------------|----------------|-----|-----|
| mm   | 0.8<br>0.6 | 0.33<br>0.23   | 0.2<br>0.1 | 1.7<br>1.5 | 0.95<br>0.75 | 1.0 | 0.5            | 1.7<br>1.5     | 0.5<br>0.3     | 0.1 | 0.1 |

| OUTLINE VERSION | REFERENCES |       |       | EUROPEAN PROJECTION | ISSUE DATE |
|-----------------|------------|-------|-------|---------------------|------------|
|                 | IEC        | JEDEC | EIAJ  |                     |            |
| SOT490          |            |       | SC-89 |                     | 98-10-23   |

PNP resistor-equipped transistors;  
R1 = 2.2 kΩ, R2 = 2.2 kΩ

PDTA123E series

Plastic surface mounted package; 3 leads

SOT346

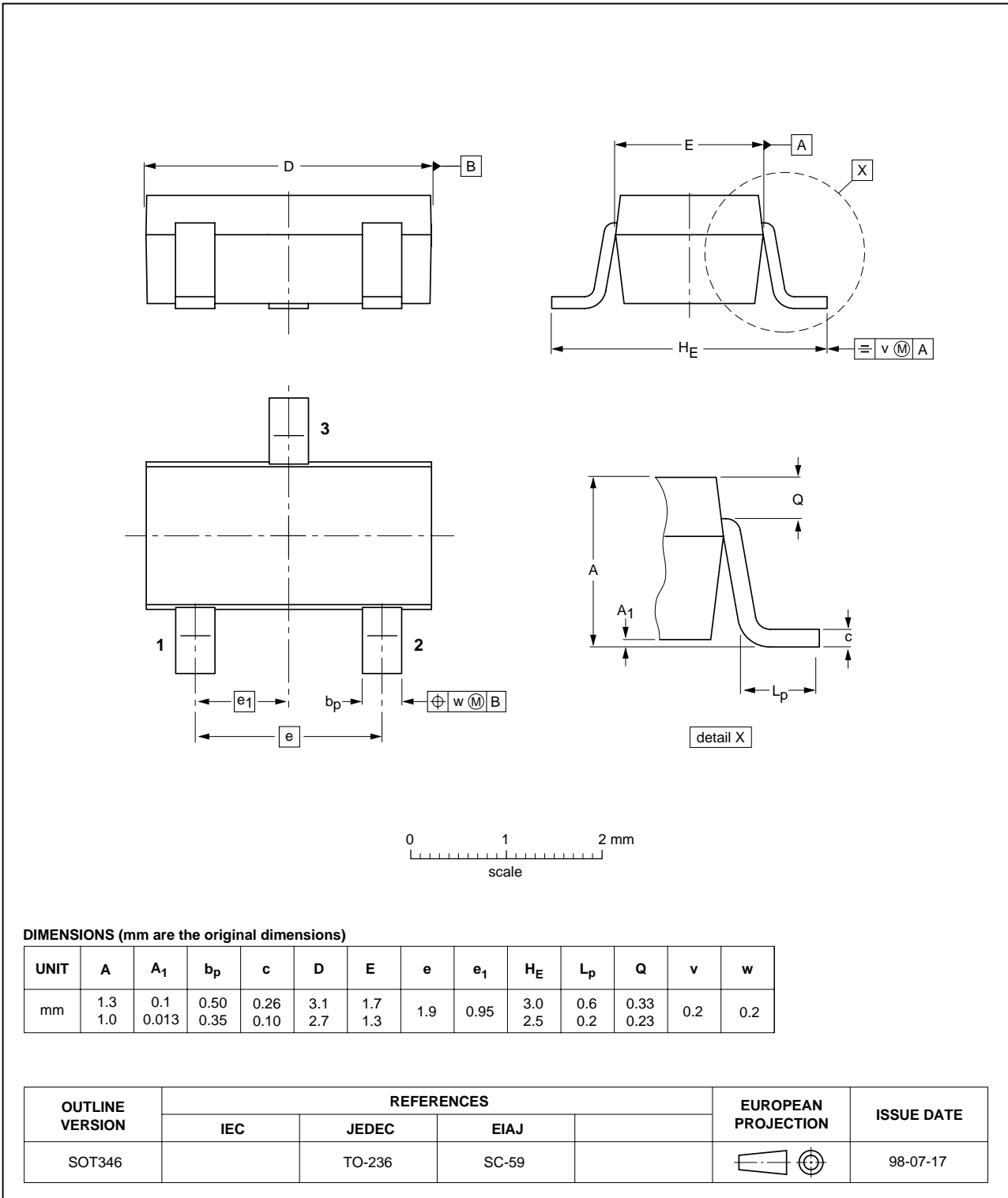

PNP resistor-equipped transistors;  
R1 = 2.2 kΩ, R2 = 2.2 kΩ

PDTA123E series

Leadless ultra small plastic package; 3 solder lands; body 1.0 x 0.6 x 0.5 mm

SOT883

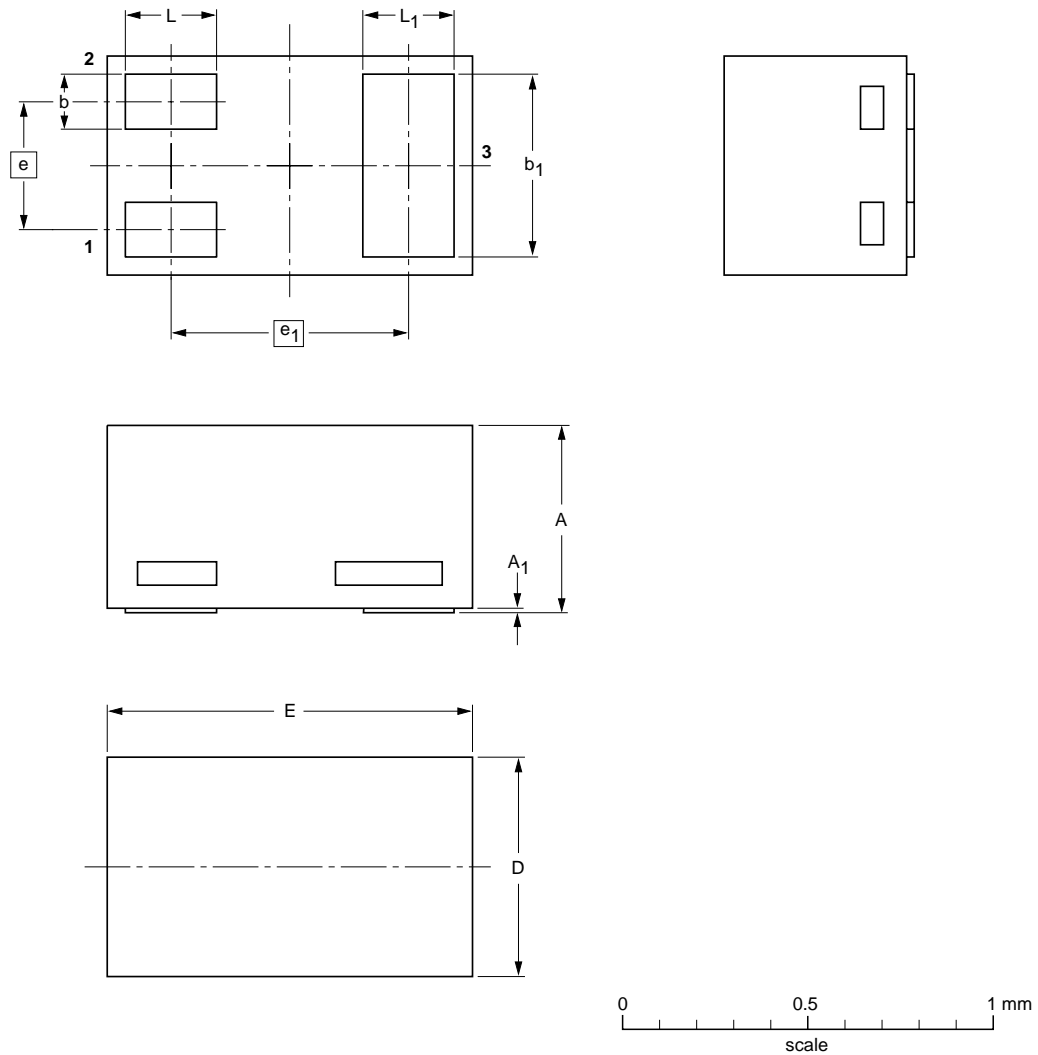

DIMENSIONS (mm are the original dimensions)

| UNIT | A <sup>(1)</sup> | A <sub>1</sub> max. | b            | b <sub>1</sub> | D            | E            | e    | e <sub>1</sub> | L            | L <sub>1</sub> |
|------|------------------|---------------------|--------------|----------------|--------------|--------------|------|----------------|--------------|----------------|
| mm   | 0.50<br>0.46     | 0.03                | 0.20<br>0.12 | 0.55<br>0.47   | 0.62<br>0.55 | 1.02<br>0.95 | 0.35 | 0.65           | 0.30<br>0.22 | 0.30<br>0.22   |

Note

1. Including plating thickness

| OUTLINE VERSION | REFERENCES |       |        | EUROPEAN PROJECTION | ISSUE DATE           |
|-----------------|------------|-------|--------|---------------------|----------------------|
|                 | IEC        | JEDEC | JEITA  |                     |                      |
| SOT883          |            |       | SC-101 |                     | 03-02-05<br>03-04-03 |

PNP resistor-equipped transistors;  
R1 = 2.2 kΩ, R2 = 2.2 kΩ

PDTA123E series

Plastic single-ended leaded (through hole) package; 3 leads

SOT54

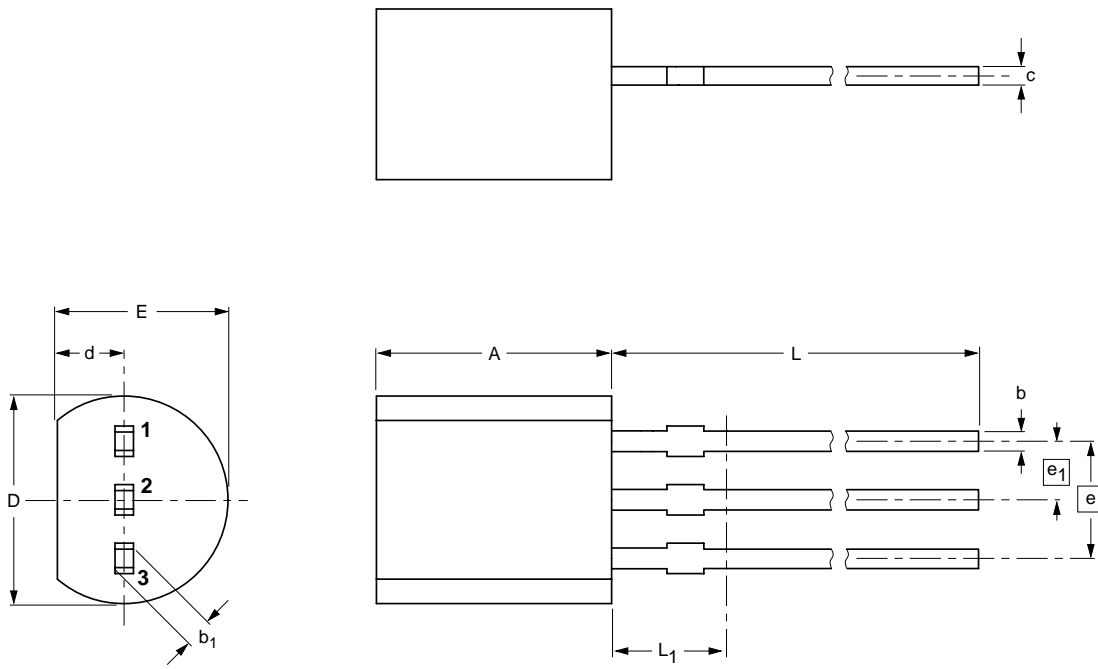

**DIMENSIONS (mm are the original dimensions)**

| UNIT | A          | b            | b <sub>1</sub> | c            | D          | d          | E          | e    | e <sub>1</sub> | L            | L <sub>1</sub> <sup>(1)</sup><br>max. |
|------|------------|--------------|----------------|--------------|------------|------------|------------|------|----------------|--------------|---------------------------------------|
| mm   | 5.2<br>5.0 | 0.48<br>0.40 | 0.66<br>0.55   | 0.45<br>0.38 | 4.8<br>4.4 | 1.7<br>1.4 | 4.2<br>3.6 | 2.54 | 1.27           | 14.5<br>12.7 | 2.5                                   |

**Note**

1. Terminal dimensions within this zone are uncontrolled to allow for flow of plastic and terminal irregularities.

| OUTLINE<br>VERSION | REFERENCES |       |        | EUROPEAN<br>PROJECTION | ISSUE DATE            |
|--------------------|------------|-------|--------|------------------------|-----------------------|
|                    | IEC        | JEDEC | JEITA  |                        |                       |
| SOT54              |            | TO-92 | SC-43A |                        | -97-02-28<br>04-06-28 |

PNP resistor-equipped transistors;  
R1 = 2.2 kΩ, R2 = 2.2 kΩ

PDTA123E series

Plastic surface mounted package; 3 leads

SOT23

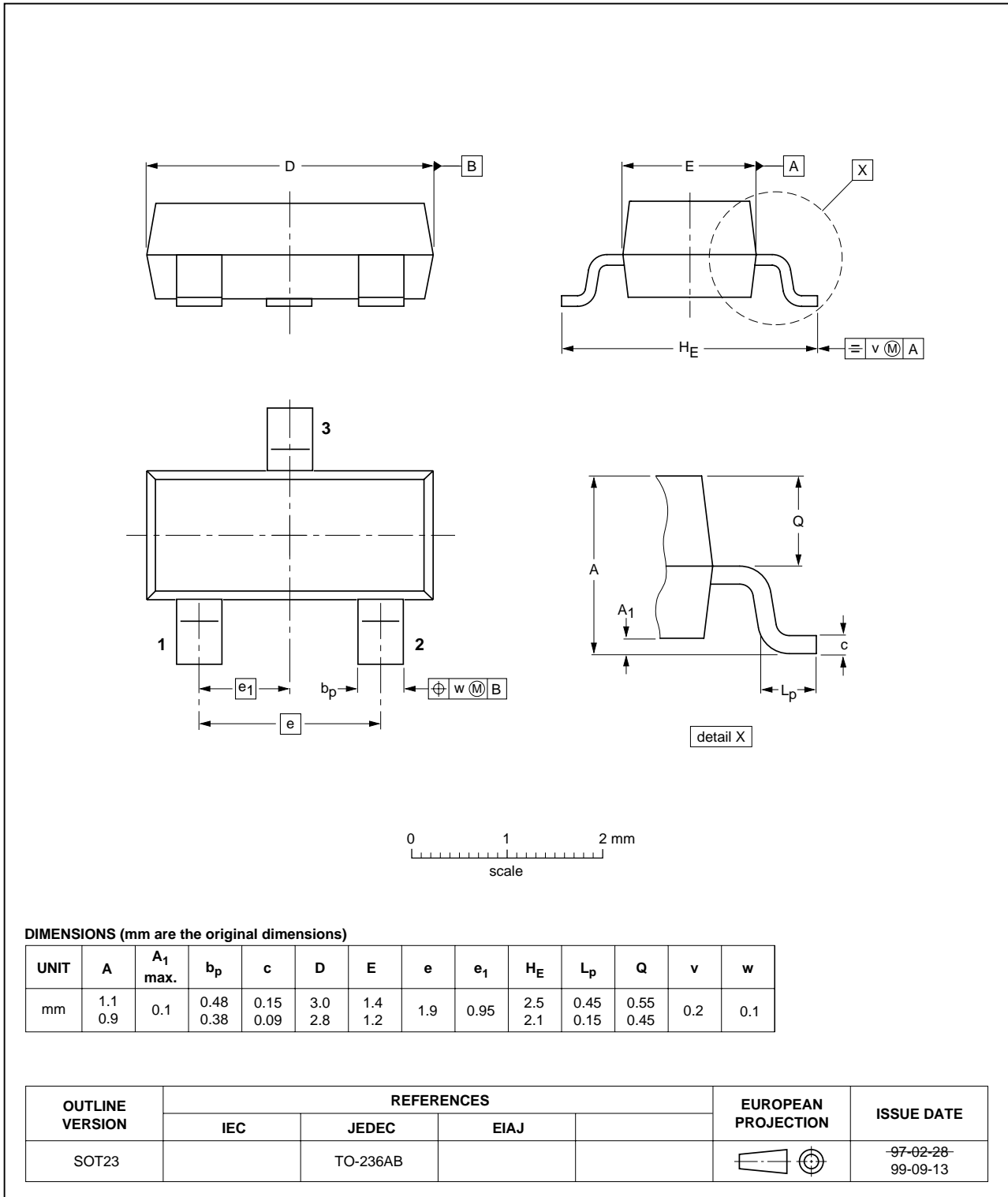

PNP resistor-equipped transistors;  
R1 = 2.2 kΩ, R2 = 2.2 kΩ

PDTA123E series

Plastic surface mounted package; 3 leads

SOT323

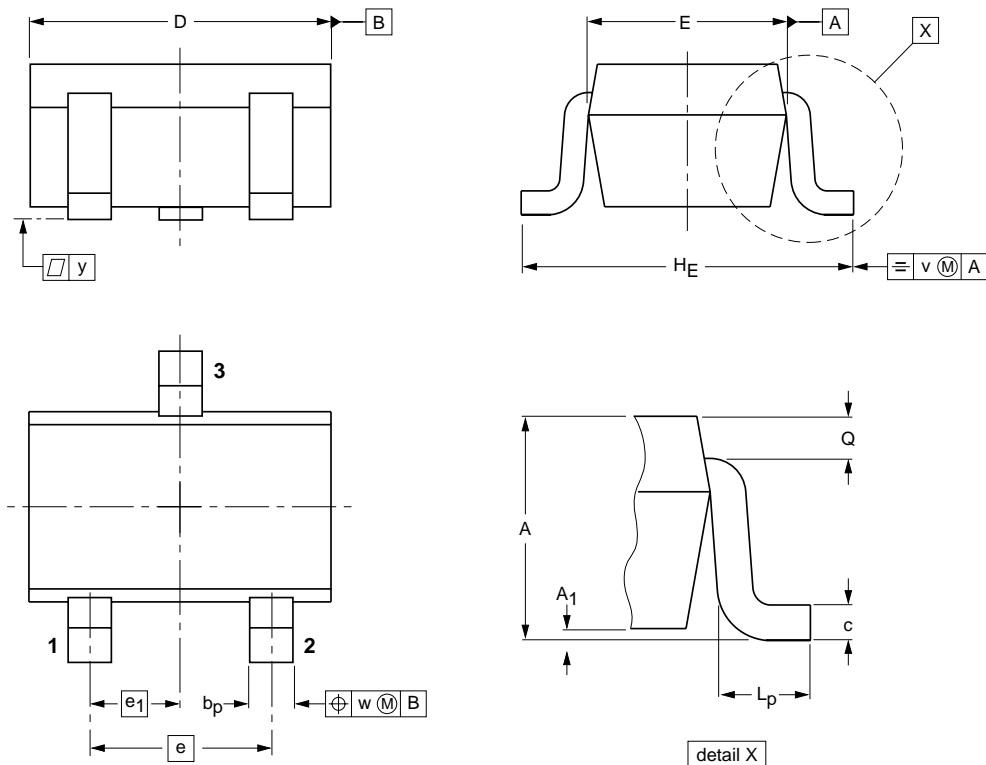

**DIMENSIONS (mm are the original dimensions)**

| UNIT | A          | A <sub>1</sub><br>max | b <sub>p</sub> | c            | D          | E            | e   | e <sub>1</sub> | H <sub>E</sub> | L <sub>p</sub> | Q            | v   | w   |
|------|------------|-----------------------|----------------|--------------|------------|--------------|-----|----------------|----------------|----------------|--------------|-----|-----|
| mm   | 1.1<br>0.8 | 0.1                   | 0.4<br>0.3     | 0.25<br>0.10 | 2.2<br>1.8 | 1.35<br>1.15 | 1.3 | 0.65           | 2.2<br>2.0     | 0.45<br>0.15   | 0.23<br>0.13 | 0.2 | 0.2 |

| OUTLINE<br>VERSION | REFERENCES |       |       |  | EUROPEAN<br>PROJECTION | ISSUE DATE |
|--------------------|------------|-------|-------|--|------------------------|------------|
|                    | IEC        | JEDEC | EIAJ  |  |                        |            |
| SOT323             |            |       | SC-70 |  |                        | 97-02-28   |

PNP resistor-equipped transistors;  
R1 = 2.2 k $\Omega$ , R2 = 2.2 k $\Omega$

PDTA123E series

#### DATA SHEET STATUS

| LEVEL | DATA SHEET STATUS <sup>(1)</sup> | PRODUCT STATUS <sup>(2)(3)</sup> | DEFINITION   |
|-------|----------------------------------|----------------------------------|--|
| I     | Objective data                   | Development                      | This data sheet contains data from the objective specification for product development. Philips Semiconductors reserves the right to change the specification in any manner without notice.  |
| II    | Preliminary data                 | Qualification                    | This data sheet contains data from the preliminary specification. Supplementary data will be published at a later date. Philips Semiconductors reserves the right to change the specification without notice, in order to improve the design and supply the best possible product.             |
| III   | Product data                     | Production                       | This data sheet contains data from the product specification. Philips Semiconductors reserves the right to make changes at any time in order to improve the design, manufacturing and supply. Relevant changes will be communicated via a Customer Product/Process Change Notification (CPCN). |

#### Notes

1. Please consult the most recently issued data sheet before initiating or completing a design.
2. The product status of the device(s) described in this data sheet may have changed since this data sheet was published. The latest information is available on the Internet at URL <http://www.semiconductors.philips.com>.
3. For data sheets describing multiple type numbers, the highest-level product status determines the data sheet status.

#### DEFINITIONS

**Short-form specification** — The data in a short-form specification is extracted from a full data sheet with the same type number and title. For detailed information see the relevant data sheet or data handbook.

**Limiting values definition** — Limiting values given are in accordance with the Absolute Maximum Rating System (IEC 60134). Stress above one or more of the limiting values may cause permanent damage to the device. These are stress ratings only and operation of the device at these or at any other conditions above those given in the Characteristics sections of the specification is not implied. Exposure to limiting values for extended periods may affect device reliability.

**Application information** — Applications that are described herein for any of these products are for illustrative purposes only. Philips Semiconductors make no representation or warranty that such applications will be suitable for the specified use without further testing or modification.

#### DISCLAIMERS

**Life support applications** — These products are not designed for use in life support appliances, devices, or systems where malfunction of these products can reasonably be expected to result in personal injury. Philips Semiconductors customers using or selling these products for use in such applications do so at their own risk and agree to fully indemnify Philips Semiconductors for any damages resulting from such application.

**Right to make changes** — Philips Semiconductors reserves the right to make changes in the products - including circuits, standard cells, and/or software - described or contained herein in order to improve design and/or performance. When the product is in full production (status 'Production'), relevant changes will be communicated via a Customer Product/Process Change Notification (CPCN). Philips Semiconductors assumes no responsibility or liability for the use of any of these products, conveys no licence or title under any patent, copyright, or mask work right to these products, and makes no representations or warranties that these products are free from patent, copyright, or mask work right infringement, unless otherwise specified.

# ***Philips Semiconductors – a worldwide company***

## **Contact information**

For additional information please visit <http://www.semiconductors.philips.com>. Fax: +31 40 27 24825

For sales offices addresses send e-mail to: [sales.addresses@www.semiconductors.philips.com](mailto:sales.addresses@www.semiconductors.philips.com).

© Koninklijke Philips Electronics N.V. 2004

SCA76

All rights are reserved. Reproduction in whole or in part is prohibited without the prior written consent of the copyright owner.

The information presented in this document does not form part of any quotation or contract, is believed to be accurate and reliable and may be changed without notice. No liability will be accepted by the publisher for any consequence of its use. Publication thereof does not convey nor imply any license under patent- or other industrial or intellectual property rights.

Printed in The Netherlands

R75/07/pp14

Date of release: 2004 Aug 02

Document order number: 9397 750 13649

*Let's make things better.*

**Philips  
Semiconductors**



**PHILIPS**