

0603HV

Fast-acting chip fuses



Product features

- 0603 (1608 metric) compact design utilizes less board space
- Rapid interruption of excessive current
- Compatible with reflow and wave solder
- Rugged ceramic and glass construction
- Excellent environmental integrity
- One time positive disconnect
- High breaking capacity up to 63 V
- Moisture sensitivity level (MSL): 1

Applications

Secondary circuit protection

- I/O Switch modules
- Printers
- Laptop, notebook, netbook
- Tablets, e-readers
- Flat panel displays
- High definition television (HDTV)
- Gaming console systems
- Handheld/portable equipment
- Mobile device chargers

Agency information

- UL Recognized File: File E19180

Ordering

- Use ordering codes (see page 3 for details)

Packaging prefixes

- TR- (5,000 parts in paper tape on a 178 mm (7") reel)

Electrical characteristics

Amp Rating	% of Amp Rating	Opening Time
500 mA – 1.5 A	100%	4 hours minimum
500 mA – 1.5 A	200%	60 seconds maximum

Product specifications

Part Number ⁵	Current rating (A)	Voltage rating (Vdc)	Interrupting rating ¹ (A)	Typical DC cold resistance ² (Ω)	Typical pre-arcing ³ I ² t (A ² s)	Typical voltage drop (V)	Part marking
0603HV500-R	0.5	63	50	1.025	0.0019	0.60	F
0603HV750-R	0.75	63	50	0.51	0.003	0.50	G
0603HV1-R	1	63	50	0.15	0.007	0.211	H
0603HV1.25-R	1.25	63	50	0.132	0.008	0.201	J
0603HV1.5-R	1.5	63	50	0.086	0.0319	0.138	K

- DC interrupting rating measured at rated voltage, time constant less than 50 microseconds, battery source
- DC cold resistance measured at <10% of rated current
- Typical pre-arcing I²t measured with a battery bank at rated dc voltage, 10x-rated current, not to exceed IR, time constant of calibrated circuit less than 50 microsecond
- Typical voltage drop measured at rated current after temperature stabilizes
- Part Number Definition: 0603HVxxx-R
 0603HV = Product code and size
 xxx - Ampere rating
 -R suffix = RoHS complaint

Dimensions—mm

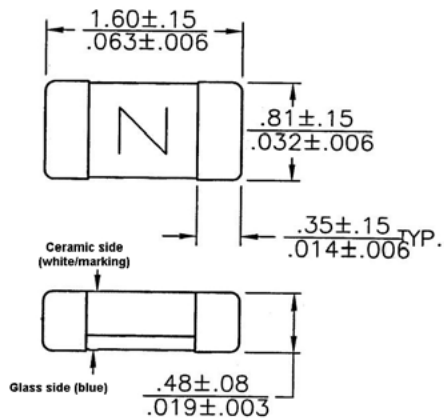

Fuse to be installed with ceramic side up (white/markings)

Recommended pad layout

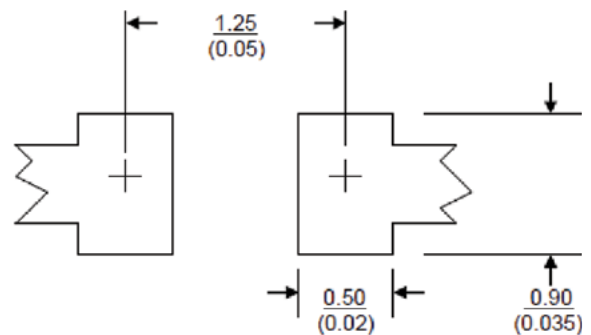

Temperature derating curve

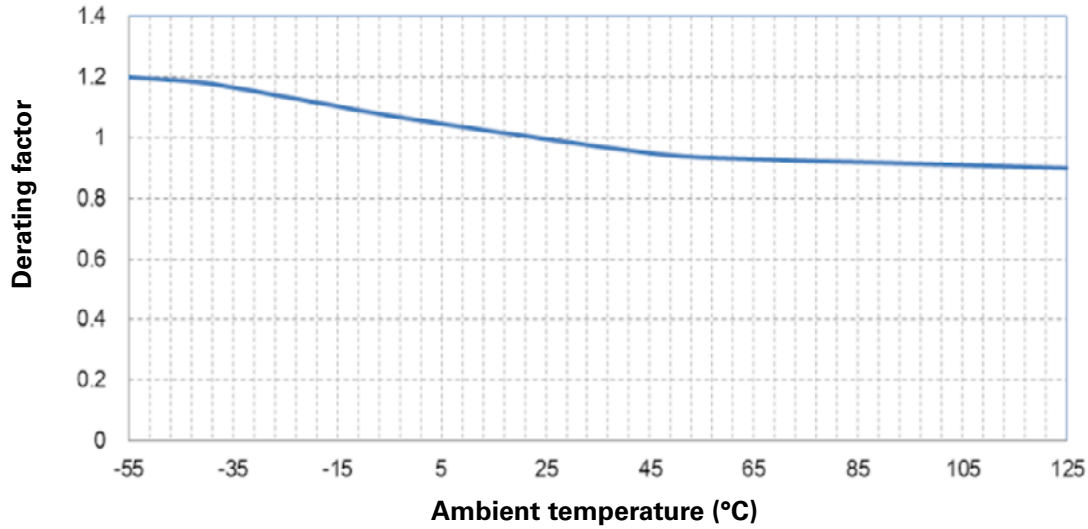

Environmental data

Operating temperature: -55 °C to +125 °C (with derating)

Storage temperature (component): -55 °C to +125 °C

Terminal strength test: Force of 1.8 kg for 60 seconds (no physical evidence of mechanical or physical damage, change in resistance < 5%)

Ordering codes

The ordering code is the part number replacing the “” with a “-” plus adding the packaging prefix.

Packaging prefix

TR- (5,000 parts in paper tape on a 178 mm (7”) reel)

Part Number	Ordering code
	TR- option
0603HV500-R	TR-0603HV500-R
0603HV750-R	TR-0603HV750-R
0603HV1-R	TR-0603HV1-R
0603HV1.25-R	TR-0603HV1-25-R
0603HV1.5-R	TR-0603HV1-5-R

Wave solder profile

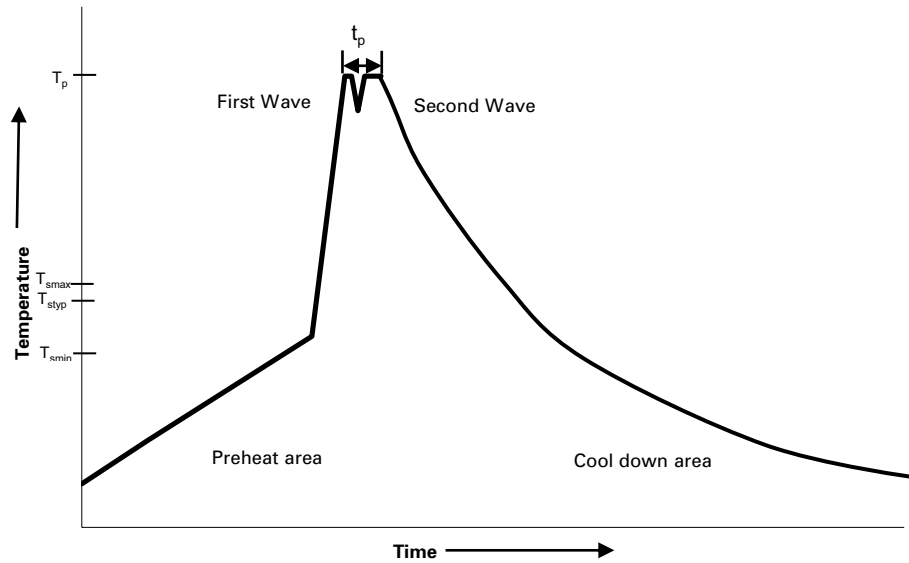

Reference EN 61760-1:2006

Profile feature	Standard SnPb solder	Lead (Pb) free solder
Preheat		
• Temperature min. (T_{smin})	100 °C	100 °C
• Temperature typ. (T_{styp})	120 °C	120 °C
• Temperature max. (T_{smax})	130 °C	130 °C
• Time (T_{smin} to T_{smax}) (t_s)	70 seconds	70 seconds
Δ preheat to max Temperature	150 °C max.	150 °C max.
Peak temperature (T_p)*	235 °C – 260 °C	250 °C – 260 °C
Time at peak temperature (t_p)	10 seconds max 5 seconds max each wave	10 seconds max 5 seconds max each wave
Ramp-down rate	~ 2 K/s min ~3.5 K/s typ ~5 K/s max	~ 2 K/s min ~3.5 K/s typ ~5 K/s max
Time 25°C to 25°C	4 minutes	4 minutes

Manual solder

+350 °C (4-5 seconds by soldering iron), generally manual/hand soldering is not recommended

Solder reflow profile

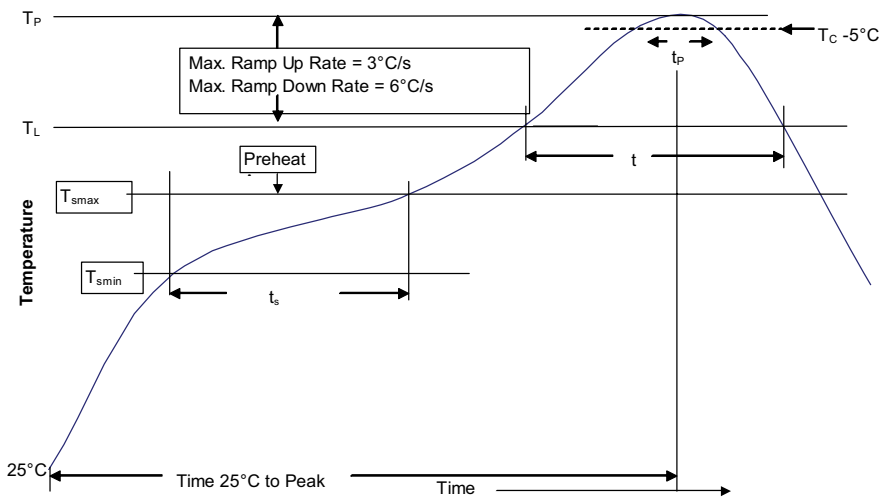

Table 1 - Standard SnPb solder (T_C)

Package thickness	Volume mm ³ <350	Volume mm ³ ≥350
<2.5 mm)	235 °C	220 °C
≥2.5 mm	220 °C	220 °C

Table 2 - Lead (Pb) free solder (T_C)

Package thickness	Volume mm ³ <350	Volume mm ³ 350 - 2000	Volume mm ³ >2000
<1.6 mm	260 °C	260 °C	260 °C
1.6 – 2.5 mm	260 °C	250 °C	245 °C
>2.5 mm	250 °C	245 °C	245 °C

Reference J-STD-020

Profile feature	Standard SnPb solder	Lead (Pb) free solder
Preheat and soak		
• Temperature min. (T_{smin})	100 °C	150 °C
• Temperature max. (T_{smax})	150 °C	200 °C
• Time (T_{smin} to T_{smax}) (t_s)	60-120 seconds	60-120 seconds
Ramp up rate T_L to T_P	3 °C/ second max.	3 °C/ second max.
Liquidous temperature (T_L)	183 °C	217 °C
Time (t_L) maintained above T_L	60-150 seconds	60-150 seconds
Peak package body temperature (T_P)*	Table 1	Table 2
Time (t_p)* within 5 °C of the specified classification temperature (T_C)	20 seconds*	30 seconds*
Ramp-down rate (T_P to T_L)	6 °C/ second max.	6 °C/ second max.
Time 25 °C to peak temperature	6 minutes max.	8 minutes max.

* Tolerance for peak profile temperature (T_P) is defined as a supplier minimum and a user maximum.

Life Support Policy: Eaton does not authorize the use of any of its products for use in life support devices or systems without the express written approval of an officer of the Company. Life support systems are devices which support or sustain life, and whose failure to perform, when properly used in accordance with instructions for use provided in the labeling, can be reasonably expected to result in significant injury to the user.

Eaton reserves the right, without notice, to change design or construction of any products and to discontinue or limit distribution of any products. Eaton also reserves the right to change or update, without notice, any technical information contained in this bulletin.

Eaton
Electronics Division
1000 Eaton Boulevard
Cleveland, OH 44122
United States
Eaton.com/electronics

© 2019 Eaton
All Rights Reserved
Printed in USA
Publication No. 11002 BU-MC19129
September 2019

Eaton is a registered trademark.

All other trademarks are property of their respective owners.

Follow us on social media to get the latest product and support information.

