

KEKOVARICON

Varistors

SMD, THD, High Energy

Varicons

Multilayer SMD and THD

Dual Function Varicons

Capacitors

Safety class X and Y disc capacitors

High voltage disc capacitors

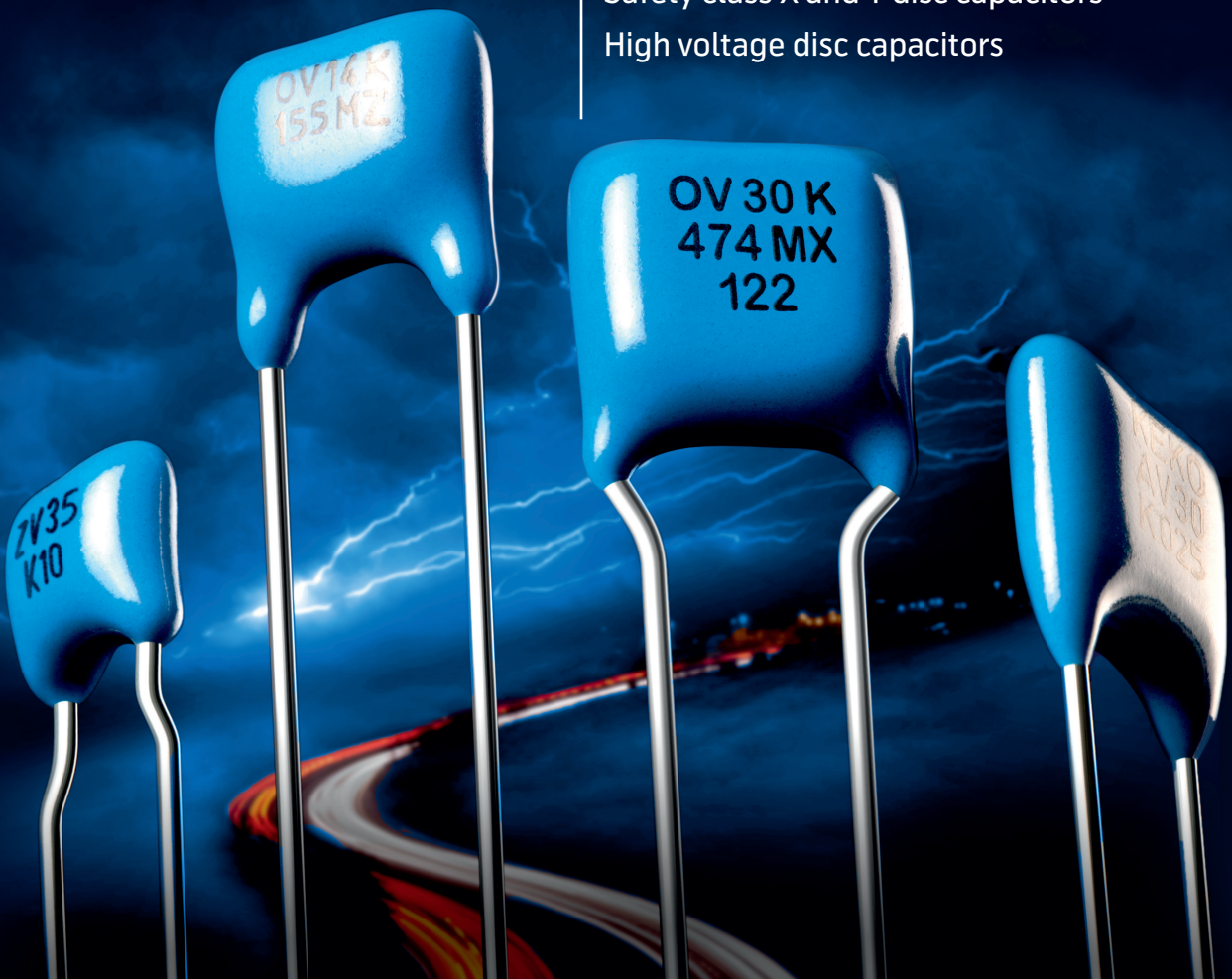

OVERVIEW OF PROTECTIVE DEVICES

Basic Electrical Parameters	Maximum Steady State Applied Voltage (Vrms)								Size (mm)	Package
	2	14	40	60	95	300	550	680		
I _{max} = 13000 to 80000 A, W _{max} = 90 to 4140 J I _{max} > 5500 A/cm ² , W _{max} > 400 J/cm ³	ZOV Series Square Shaped High Energy Varistors								23, 25, 32, 40, 60	
I _{max} = 15000 to 40000 A, W _{max} = 30 to 2590 J	ZOVR Series Round Shaped High Energy Varistors								25, 32, 40	
I _{max} (8/20μs) up to 150 kA, I _{imp} (10/350μs) up to 25 kA Custom Design	ZOVH / ZOVS Series High Energy Varistors for class I applications								40, 40 D2, 40 D4 (80,120)	
I _{max} = 600 to 15000 A, W _{max} = 4 to 815 J I _{max} > 5500 A/cm ² , W _{max} > 400 J/cm ³	SV Series Special Medium Voltage Varistors								5, 7, 10, 14, 20, 23	
I _{max} = 1750 to 15000 A, W _{max} = 9 to 627 J	CV+ Series Medium Voltage Varistors								7, 10, 14, 20, 23	
I _{max} = 400 to 6500 A, W _{max} = 2,7 to 620 J	CV Series Medium Voltage Varistors								5, 7, 10, 14, 20	
KM - C = 10 to 15 nF, Class X1, 300 VAC KM - C = 1 to 10 nF, Class Y2, 300 VAC KZL, KZH - C = 330 to 4700 pF, Class X1/Y1/Y2, 300/500 VAC	KM Series RFI Suppression Ceramic Capacitors KZ Series Safety Ceramic Capacitors								330 pF to 10 nF	
C = 300pF to 10nF Vr = 1kV to 6kV					KV Series High Voltage Disc Ceramic Capacitors				330 pF to 10 nF	
I _{max} = 100 to 1200 A, W _{max} = 0,6 to 30 J	PV Series Low & Medium Voltage Varistors								3225, 4032	
I _{max} = 100 to 1200 A, W _{max} = 0,6 to 30 J	DV Series Medium Voltage Varicons								2220, 3225, 4032	
I _{max} = 1500 A, W _{max} = 0,1 to 2,6 J C (@ 1kHz) = 10 nF to 1000 nF	MV Series Low Voltage Dual Function Varicons								5	
I _{max} = 20 to 2000 A, W _{max} = 0,1 to 37,8 J	ZV Series Low Voltage Varicons								5, 7, 10, 14, 20	
I _{max} = 30 to 40 A W _{max} = 1,0 J	ZVX Series Low Capacitance & Low Energy Varicons								0603, 0805, 1206	
tr < 1 ns, W _{max} = 0,05 to 0,1 J	ZVE Series ESD Suppression Varicons								0603, 0805, 1206, 1210	
CL and C Series: C = 1pF to 4,7μF, V = from 16 V to 630 V X7R, C series: AgPd, Barrier End Terminations, Ni / Sn End terminations	CL Series Through-Hole MLC Capacitor C Series SMD MLC Capacitor								5, 6, 8, 9	
I _{max} = 800 to 1200 A, WLD = 6 to 12 J C (@ 1kHz) = 470 nF to 1500 nF Custom Design	OV Series Automotive Dual Function Varicons								8, 9	
I _{max} = 120 to 2000 A, WLD = 3 to 100 J Custom Design	AV Series Automotive Varicons								6, 8, 8, 11	
	3	14	18	56	85	125	385	895	745	
	Maximum Steady State Applied DC Voltage (Vdc)									

KEKO VARICON products are sold by description only - product technical specification. KEKO VARICON reserves the right to make changes in circuit design and/or specifications at any time without notice. Accordingly the reader is cautioned to verify that data sheets are current before placing orders. Information furnished by KEKO VARICON is believed to be accurate and reliable. However, no responsibility is assumed by KEKO VARICON for its use; nor for any infringements of patents or other rights of third parties which may result from its use.

APPLICATION FIELDS

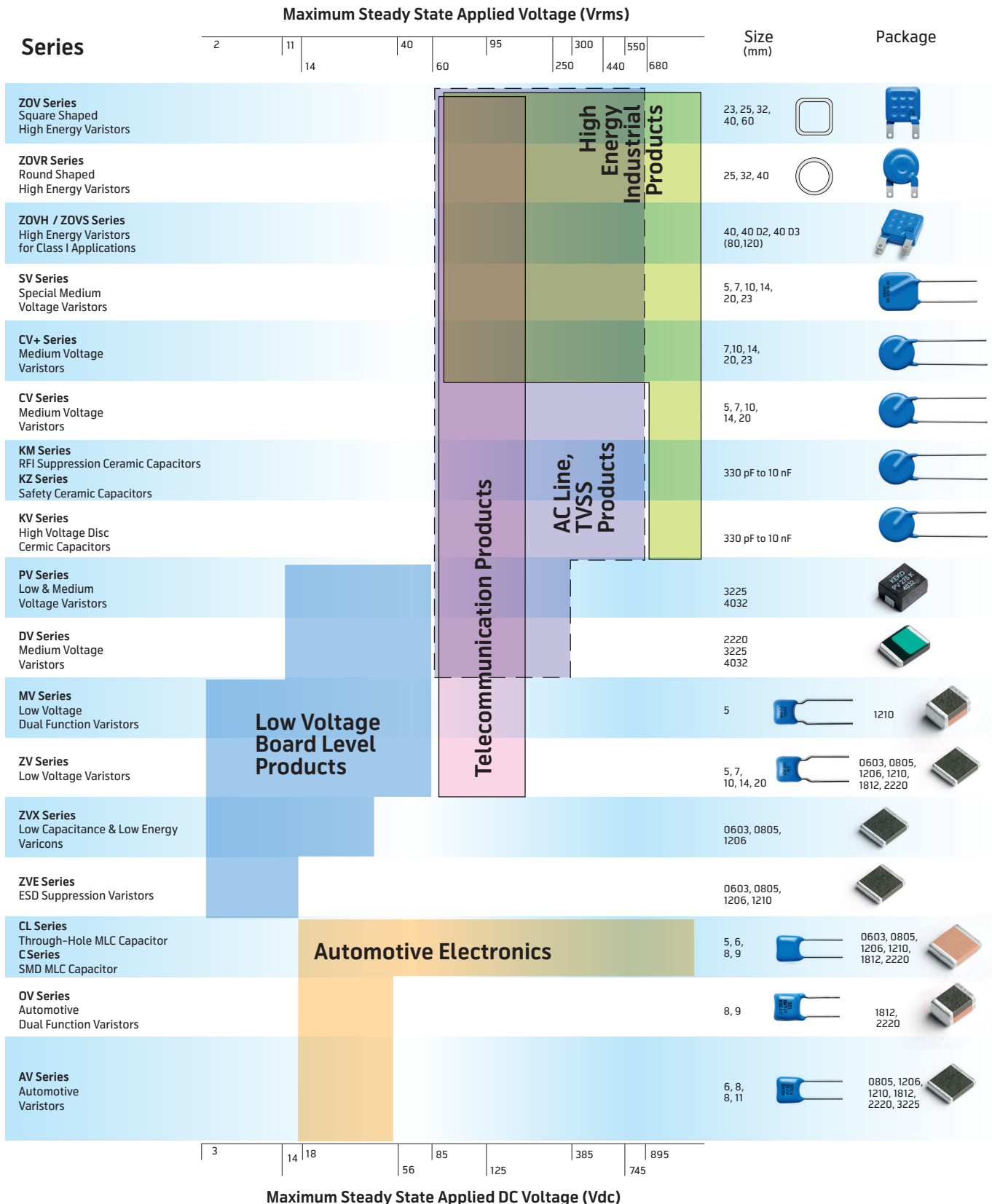

KEKO VARICON products are sold by description only - product technical specification. KEKO VARICON reserves the right to make changes in circuit design and/or specifications at any time without notice. Accordingly the reader is cautioned to verify that data sheets are current before placing orders. Information furnished by KEKO VARICON is believed to be accurate and reliable. However, no responsibility is assumed by KEKO VARICON for its use; nor for any infringements of patents or other rights of third parties which may result from its use.

LOW & MEDIUM VOLTAGE PLASTICS-ENCAPSULATED VARISTORS - PV SERIES

Description

The PV series of low & medium voltage plastic-encapsulated varistors is designed to protect electronic equipment against high voltage surges in the low & medium voltage region. They offer direct SMD equivalents to leaded disc varistors of 5 and 7 mm sizes. The thermoplastic encapsulation is non-flammable according to the standard UL 94 V-0. Contacts are made of tinned copper sheet.

PV varistors are designed for surface mounting and are available in two model sizes. These transient voltage suppressors cover an operating voltage V_{rms} from 11 V to 300 V, featuring maximum surge currents from 100 A to 1200 A.



Features

- Fully lead-free component
- Operating voltage range V_{dc}14 V to 385 V
- Operating voltage V_{rms}11 V to 300 V
- 2 model sizes available3255 and 4032
- + 85 °C continuous operating temperature
- Dimensional and weight savings on board
- Easy solderable tinned copper sheet
- Non-flammable thermoplastic encapsulation according to the standard UL 94 V-0
- Available in tape and reel for automatic pick and place
-  UL 1449, 3rd edition & CSA C22.2, File E326499 Section 3.

Absolute Maximum Ratings

Continuous:	Units	Value
Steady State Applied Voltage:		
DC Voltage Range (V_{dc})	V	14 to 385
AC Voltage Range (V_{rms})	V	11 to 300
Transient:		
Non-Repetitive Surge Current, 8/20 μ s Waveform (I_{max})	A	100 to 1200
Non-Repetitive Surge Energy, 10/1000 μ s Waveform (W_{max})	J	0,6 to 30
Operating Ambient Temperature	°C	-40 to +85
Storage Temperature	°C	-40 to +125
Threshold Voltage Temperature Coefficient	%/°C	< + 0,05
Response Time	ns	< 5
Climatic Category		40 / 85 / 56

Device Ratings and Characteristics

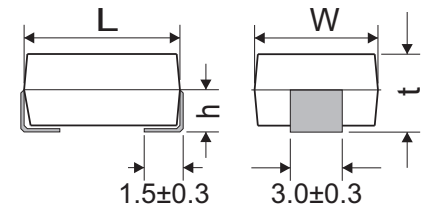

PV 11 K 3225.....PV 300 K 4032

Type	V _{rms} V	V _{dc} V	V _n @ 1 mA V	V _c V	I _c A	W _{max} 10/1000 μs J	P max W	I _{max} 8/20 μs A	C typ. @ 1 kHz pF	h ±0,3 mm	L ±0,5 mm	W ±0,4 mm	t ±0,3 mm
PV 11 K 3225	11	14	18	36	2,5	0,6	0,01	100	1600	1,7	8,0	6,3	3,4
PV 11 K 4032	11	14	18	36	5	1,1	0,02	250	3100	2,3	10,0	8,0	4,7
PV 14 K 3225	14	18	22	43	2,5	0,7	0,01	100	1300	1,7	8,0	6,3	3,4
PV 14 K 4032	14	18	22	43	5	1,3	0,02	250	2500	2,3	10,0	8,0	4,7
PV 17 K 3225	17	22	27	53	2,5	0,9	0,01	100	1050	1,7	8,0	6,3	3,4
PV 17 K 4032	17	22	27	53	5	1,6	0,02	250	1900	2,3	10,0	8,0	4,7
PV 20 K 3225	20	26	33	65	2,5	1,1	0,01	100	750	1,7	8,0	6,3	3,4
PV 20 K 4032	20	26	33	65	5	2,0	0,02	250	1500	2,3	10,0	8,0	4,7
PV 25 K 3225	25	31	39	77	2,5	1,2	0,01	100	660	1,7	8,0	6,3	3,4
PV 25 K 4032	25	31	39	77	5	2,4	0,02	250	1260	2,3	10,0	8,0	4,7
PV 30 K 3225	30	38	47	93	2,5	1,5	0,01	100	580	1,7	8,0	6,3	3,4
PV 30 K 4032	30	38	47	93	5	2,8	0,02	250	1050	2,3	10,0	8,0	4,7
PV 35 K 3225	35	45	56	110	2,5	1,8	0,01	100	460	1,7	8,0	6,3	3,4
PV 35 K 4032	35	45	56	110	5	3,4	0,02	250	850	2,3	10,0	8,0	4,7
PV 40 K 3225	40	56	68	135	2,5	2,2	0,01	100	400	1,7	8,0	6,3	3,4
PV 40 K 4032	40	56	68	135	5	4,1	0,02	250	720	2,3	10,0	8,0	4,7
PV 50 K 3225	50	65	82	135	5	2,5	0,10	400	390	1,7	8,0	6,3	3,4
PV 50 K 4032	50	65	82	135	10	6,5	0,25	1200	820	2,3	10,0	8,0	4,7
PV 60 K 3225	60	85	100	165	5	3,0	0,10	400	330	1,7	8,0	6,3	3,4
PV 60 K 4032	60	85	100	165	10	7,0	0,25	1200	680	2,3	10,0	8,0	4,7
PV 75 K 3225	75	100	120	200	5	4,0	0,10	400	270	1,7	8,0	6,3	3,4
PV 75 K 4032	75	100	120	200	10	9,0	0,25	1200	550	2,3	10,0	8,0	4,7
PV 95 K 3225	95	125	150	250	5	6,0	0,10	400	220	1,7	8,0	6,3	3,4
PV 95 K 4032	95	125	150	250	10	11,0	0,25	1200	440	2,3	10,0	8,0	4,7
PV 115 K 3225	115	150	180	300	5	6,5	0,10	400	180	1,7	8,0	6,3	3,4
PV 115 K 4032	115	150	180	300	10	13,0	0,25	1200	360	2,3	10,0	8,0	4,7
PV 130 K 3225	130	170	205	340	5	7,0	0,10	400	160	1,7	8,0	6,3	3,4
PV 130 K 4032	130	170	205	340	10	15,0	0,25	1200	320	2,3	10,0	8,0	4,7
PV 140 K 3225	140	180	220	360	5	7,5	0,10	400	150	1,7	8,0	6,3	3,4
PV 140 K 4032	140	180	220	360	10	18,0	0,25	1200	300	2,3	10,0	8,0	4,7
PV 150 K 3225	150	200	240	395	5	9,0	0,10	400	140	1,7	8,0	6,3	3,4
PV 150 K 4032	150	200	240	395	10	18,5	0,25	1200	280	2,3	10,0	8,0	4,7
PV 175 K 3225	175	225	270	455	5	9,5	0,10	400	120	2,3	8,0	6,3	4,7
PV 175 K 4032	175	225	270	455	10	21,0	0,25	1200	250	2,3	10,0	8,0	4,7
PV 230 K 3225	230	300	360	595	5	10,0	0,10	400	95	2,3	8,0	6,3	4,7
PV 230 K 4032	230	300	360	595	10	23,0	0,25	1200	190	2,3	10,0	8,0	4,7
PV 250 K 3225	250	320	390	650	5	11,0	0,10	400	80	2,3	8,0	6,3	4,7
PV 250 K 4032	250	320	390	650	10	25,0	0,25	1200	180	2,3	10,0	8,0	4,7
PV 275 K 3225	275	350	430	710	5	13,0	0,10	400	75	2,3	8,0	6,3	4,7
PV 275 K 4032	275	350	430	710	10	29,0	0,25	1200	160	2,3	10,0	8,0	4,7
PV 300 K 3225	300	385	470	775	5	15,0	0,10	400	70	2,3	8,0	6,3	4,7
PV 300 K 4032	300	385	470	775	10	30,0	0,25	1200	150	2,3	10,0	8,0	4,7

KEKO VARICON products are sold by description only - product technical specification. KEKO VARICON reserves the right to make changes in circuit design and/or specifications at any time without notice. Accordingly the reader is cautioned to verify that data sheets are current before placing orders. Information furnished by KEKO VARICON is believed to be accurate and reliable. However, no responsibility is assumed by KEKO VARICON for its use; nor for any infringements of patents or other rights of third parties which may result from its use.

Protection Level

Model Size 3225

Pulse Rating Curves

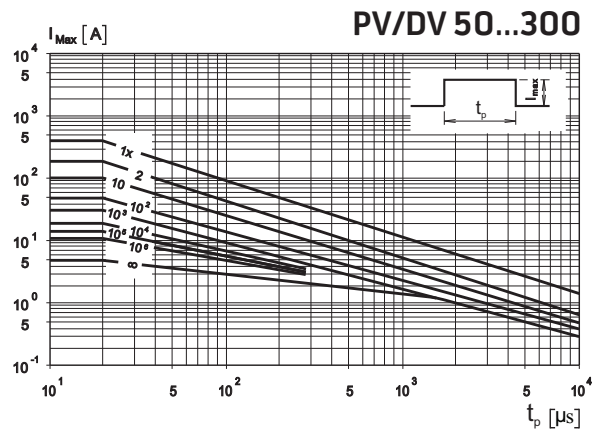
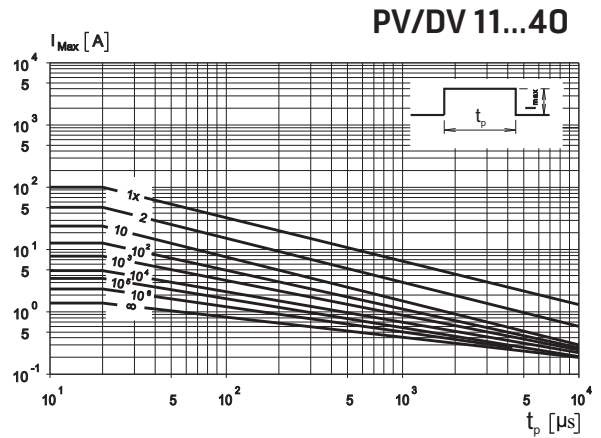
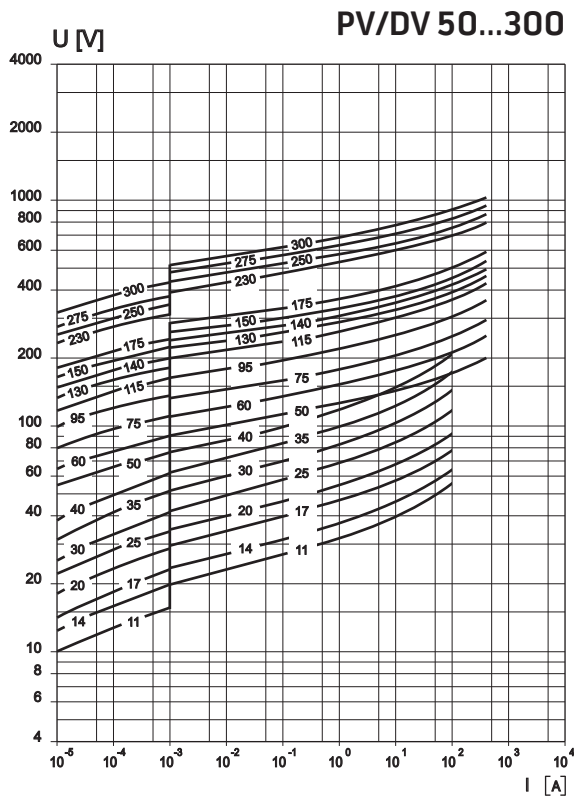

Model Size 4032

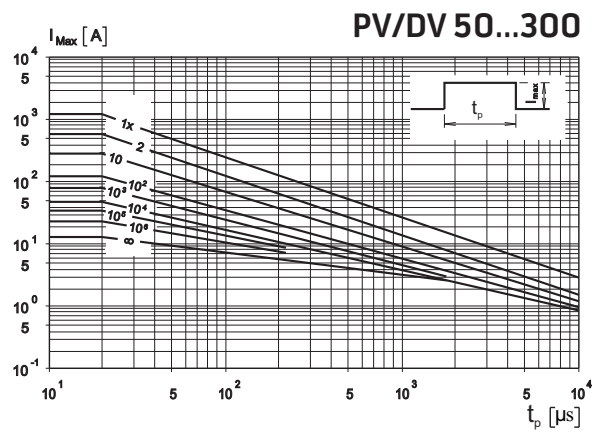
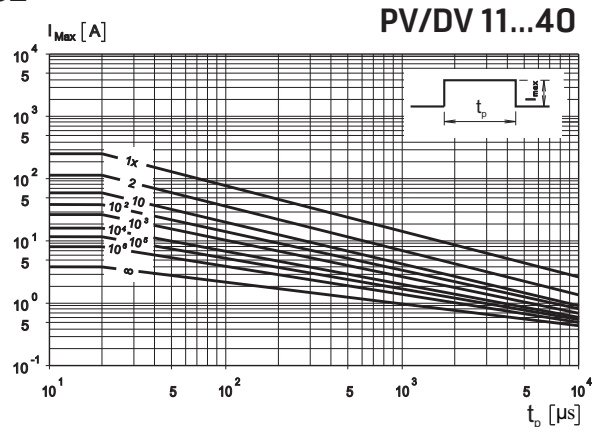
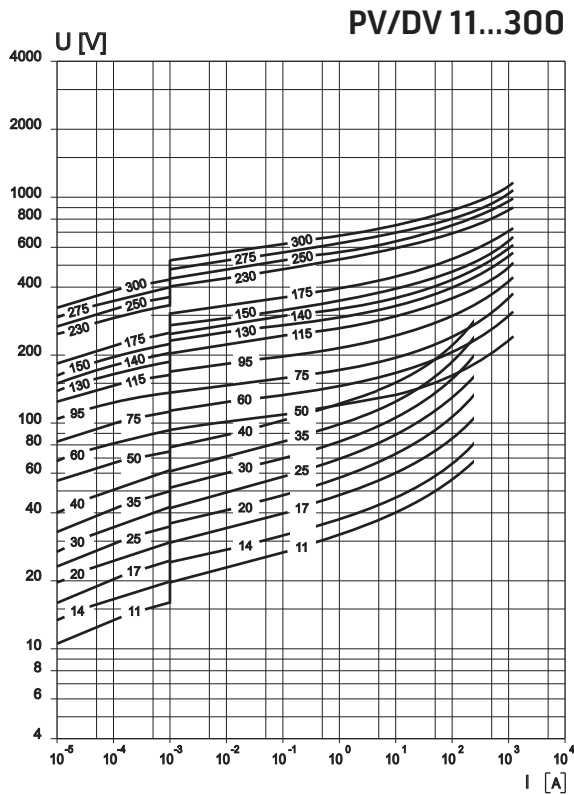

KEKO VARICON products are sold by description only - product technical specification. KEKO VARICON reserves the right to make changes in circuit design and/or specifications at any time without notice. Accordingly the reader is cautioned to verify that data sheets are current before placing orders. Information furnished by KEKO VARICON is believed to be accurate and reliable. However, no responsibility is assumed by KEKO VARICON for its use; nor for any infringements of patents or other rights of third parties which may result from its use.

Soldering Pad Configuration

DV Series

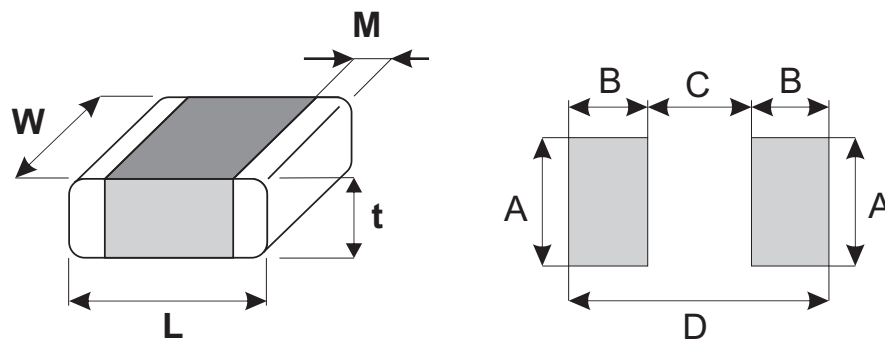

Size	Voltage range (V)	L ± 0,5 (mm)	W ± 0,4 (mm)	M ± 0,25 (mm)	t _{max} (mm)	A (mm)	B (mm)	C (mm)	D (mm)
3225	11 to 300	8,0	6,3	0,5	2,0	6,8	1,5	6,5	9,5
4032	11 to 300	10,0	8,3	0,5	2,0	6,8	1,5	8,7	11,7

* size 2220 available upon request

PV Series

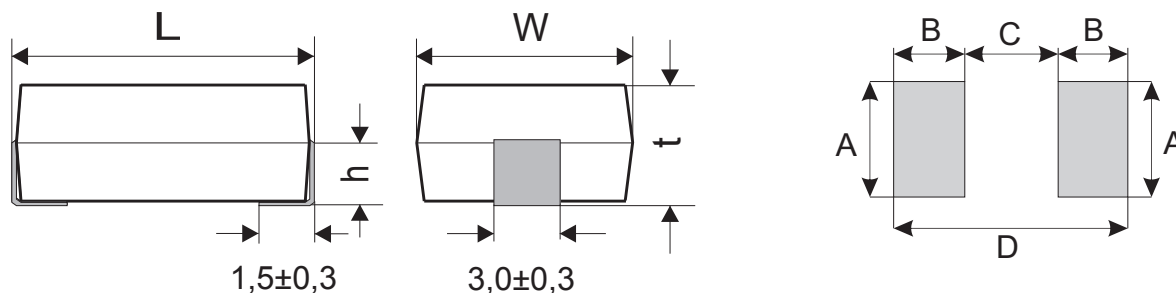

Size	Voltage range (V)	L ± 0,5 (mm)	W ± 0,4 (mm)	h ± 0,3 (mm)	t ± 0,3 (mm)	A (mm)	B (mm)	C (mm)	D (mm)
3225	11 to 150	8,0	6,3	1,7	3,4	3,5	2,9	4,5	10,3
3225	175 to 300	8,0	6,3	2,3	4,7	3,5	2,9	4,5	10,3
4032	11 to 300	10,0	8,3	2,3	4,7	3,5	2,9	6,5	12,3

Device Ratings and Characteristics

Conforms to IEC Publication 286 - 3 Ed.4: 2007-06

Tape

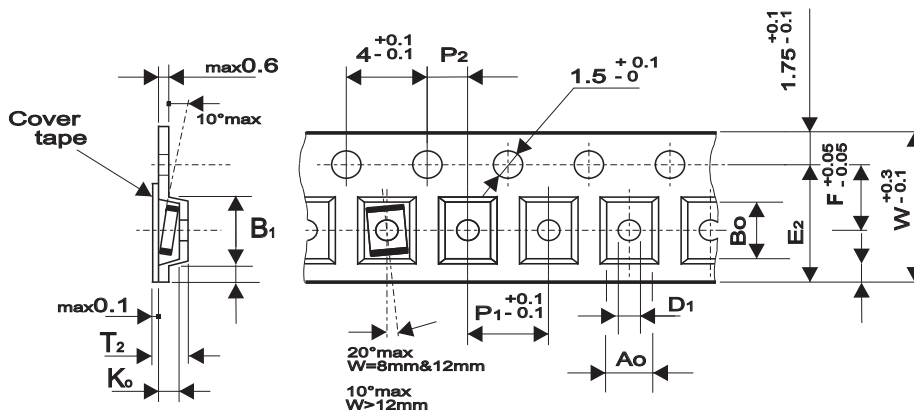

Reel

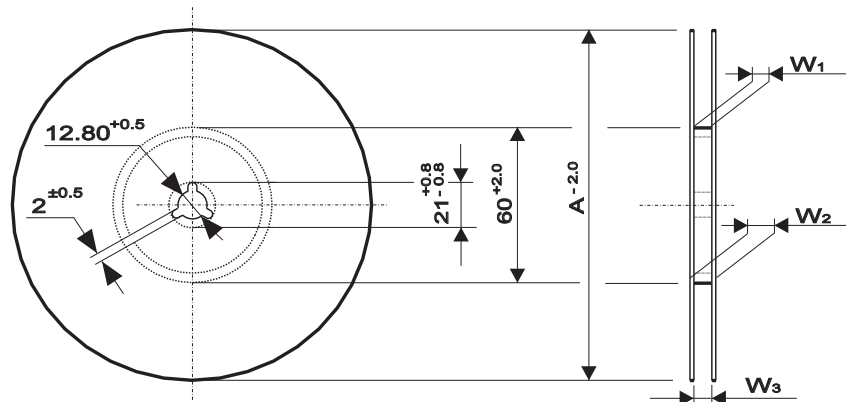

Variable dimensions

Tape Size		16mm	
Size	Units	3225	4032
Size	(mm)	7	8,6
Ao	(mm)	7,8	10,8
Bo	(mm)	3,7	3,7
Ko max	(mm)	12,1	12,1
B1 max	(mm)	1,5	1,5
D1 max	(mm)	14,25	14,25
e2	(mm)	12	12
P1	(mm)	7,5	7,5
F	(mm)	16,0	16,0
W	(mm)	9,5	9,5
T2 max	(mm)	16,4+2	16,4+2
W1	(mm)	22,4	22,4
W2 max	(mm)	15,9...19,4	15,9...19,4
A	(mm)	330	330

Package units

Series	Chip Size	
	3225	4032
DV	1500	1500
PV < 175	1500	1000
PV > 175	1000	1000

KEKO VARICON products are sold by description only - product technical specification. KEKO VARICON reserves the right to make changes in circuit design and/or specifications at any time without notice. Accordingly the reader is cautioned to verify that data sheets are current before placing orders. Information furnished by KEKO VARICON is believed to be accurate and reliable. However, no responsibility is assumed by KEKO VARICON for its use; nor for any infringements of patents or other rights of third parties which may result from its use.

Ordering Information

PV 20 K 3225 R2 yy

PV	- Series Name
20	- V_{rms}
K	- V_n Tolerance: K = $\pm 10\%$
3225	- Model Size: 3225, 4032
R2	- Packaging: R2 = Reel 330 mm
yy	- Special requirements

DV 20 K 3225 N R2 yy

DV	- Series Name
20	- V_{rms}
K	- V_n Tolerance: K = $\pm 10\%$
3225	- Model Size: 3225, 4032
N	- Barrier type end terminations suitable for Pb-free and Pb reflow soldering
R2	- Packaging: R2 = Reel 330 mm
yy	- Special requirements

Varistor Marking for PV Series

KEKO PV 20 K 3225

KEKO	- Tradename
PV	- Series Name
20	- V_{rms}
K	- V_n Tolerance
3225	- Model Size
ww/yy	- Date code on request

SOLDERING RECOMMENDATIONS

Popular soldering techniques used for surface mounted components are Wave and Infrared Reflow processes. Both processes can be performed with Pb-containing or Pb-free solders. The termination options available for these soldering techniques are AgPd and Barrier Type End Terminations.

End termination	Designation	Recommended and Suitable for	Component RoHS Compliant
Ag/Pd	Series (ZV, AV, DV, C, ...)..... R1	Pb-containing soldering	Yes
Barrier Type End Termination	Series (ZV, AV, DV, C, ...)..... N R1	Pb-containing and Pb-free soldering	Yes
Ni Sn End Termination	Series (ZV, AV, ...) ...Ni R1	Pb-containing and Pb-free soldering v	Yes

Wave Soldering – this process is generally associated with discrete components mounted on the underside of printed circuit boards, or for large top-side components with bottom-side mounting tabs to be attached, such as the frames of transformers, relays, connectors, etc. SMD varistors to be wave soldered are first glued to the circuit board, usually with an epoxy adhesive. When all components on the PCB have been positioned and an appropriate time is allowed for adhesive curing, the completed assembly is then placed on a conveyor and run through a single, double wave process.

Infrared Reflow Soldering – these reflow processes are typically associated with top-side component placement. This technique utilizes a mixture of adhesive and solder compounds (and sometimes fluxes) that are blended into a paste. The paste is then screened onto PCB soldering pads specifically designed to accept a particular sized SMD component. The recommended solder paste wet layer thickness is 100 to 300 μm . Once the circuit board is fully populated with MD components, it is placed in a reflow environment, where the paste is heated to slightly above its eutectic temperature. When the solder paste reflows, the SMD components are attached to the solder pads.

Solder Fluxes – solder fluxes are generally applied to populated circuit boards to lean oxides form forming during the heating process and to facilitate the flowing of the solder. Solder fluxes can be either a part of the solder paste compound or can be separate materials, usually fluids. Recommended fluxes are:

- non-activated (R) fluxes, whenever possible
- mildly activated (RMA) fluxes of class L3CN
- class ORLO

Activated (RA), water soluble or strong acidic fluxes with a chlorine content > 0.2 wt. % are NOT RECOMMENDED. The use of such fluxes could create high leakage current paths along the body of the varistor components.

When a flux is applied prior to wave soldering, it is important to completely dry any residual flux solvents prior to the soldering process.

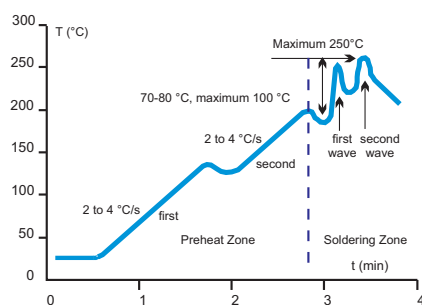

Fig. 1. Wave Soldering Temperature Profile for Pb-free and Pb-containing Soldering

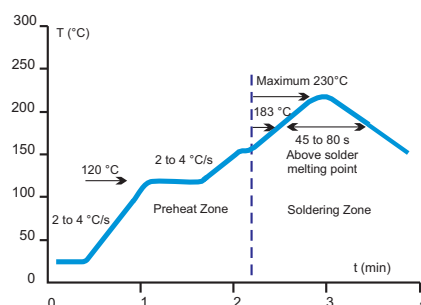

Fig. 2. Infrared Reflow Temperature Profile for Pb-containing Soldering

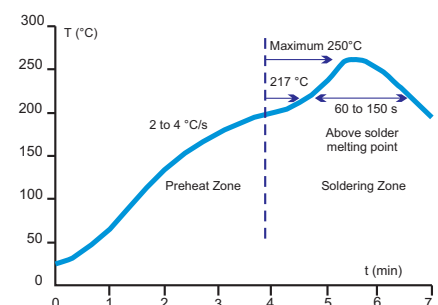

Fig. 3. Reflow Temperature Profile for Pb-free Soldering

Thermal Shock – to avoid the possibility of generating stresses in the varistor chip due to thermal shock, a preheat stage to within 100 °C of the peak soldering process temperature is recommended. Additionally, SMD varistors should not be subjected to a temperature gradient greater than 4 °C/sec., with an ideal gradient being 2 °C/sec. Peak temperatures should be controlled. Wave and Reflow soldering conditions for SMD varistors with Pb-containing solders are shown in Fig. 1 and 2 respectively, while Wave and Reflow soldering conditions for SMD varistors with Pb-free solders are shown in Fig. 1 and 3.

Whenever several different types of SMD components are being soldered, each having a specific soldering profile, the soldering profile with the least heat and the minimum amount of heating time is recommended. Once soldering has been completed, it is necessary to minimize the possibility of thermal shock by allowing the hot PCB to cool to less than 50 °C before cleaning.

Inspection Criteria – the inspection criteria to determine acceptable solder joints, when Wave or Infrared Reflow processes are used, will depend on several key variables, principally termination material process profiles.

Pb-containing Wave and IR Reflow Soldering – typical “before” and “after” soldering results for Silver/Palladium (AgPd) and Barrier Type End Terminations can be seen in Fig. 4. Both barrier type and silver/palladium terminated varistors form a reliable electrical contact and metallurgical bond between the end terminations and the solder pads. The bond between these two metallic surfaces is exceptionally strong and has been tested by both vertical pull and lateral (horizontal) push tests. The results, in both cases, exceed established industry standards for adhesion.

The solder joint appearance of a barrier type terminated versus a silver/palladium terminated varistor will be slightly different. Solder forms a metallurgical junction with the thin tin-alloy (over the barrier layer), and due to its small volume “climbs” the outer surface of the terminations, the meniscus will be slightly lower. This optical appearance difference should be taken into consideration when programming visual inspection of the PCB after soldering.

Silver Palladium (AgPd) End Terminations

Barrier Type End Terminations and Ni Sn End Terminations

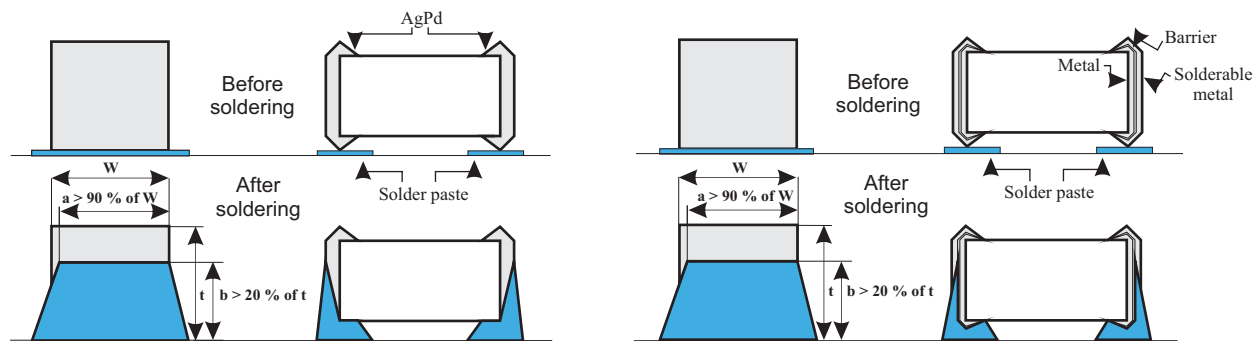

Fig. 4 Soldering Criterion in case of Wave and IR Reflow Pb-containing Soldering

Silver Palladium (AgPd) End Terminations

Barrier Type End Terminations and Ni Sn End Terminations

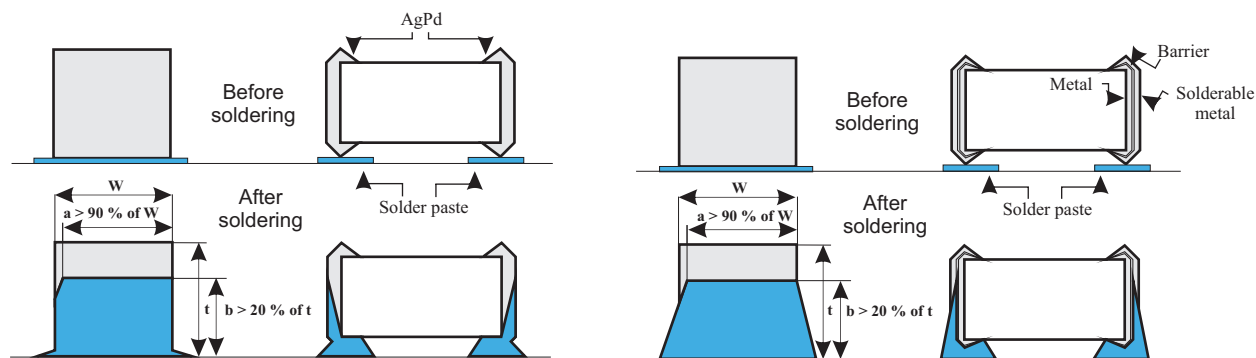

Fig. 5 Soldering Criterion in case of Wave and IR Reflow Pb-free Soldering

Pb-free Wave and IR Reflow Soldering – typical “before” and “after” soldering results for Silver/Palladium (AgPd) and Barrier Type End Terminations are given in A phenomenon known as “mirror” or “negative” meniscus results will appear in the case of Silver/Palladium terminated varistors. Solder forms a metallurgical junction with the entire volume of the end termination, i.e. it diffuses from pad to end termination across the inner side, forming a “mirror” or “negative meniscus. The height of the solder penetration can be clearly seen on the end termination and is always 30% higher than the chip height.

Since barrier type terminations on KEKO-VARICON chips do not require the use of problematic nickel and tin-alloy electroplating processes, these varistors are truly considered environmentally friendly.

Solder Test and Retained Samples – reflow soldering test based on J-STD-020D.1 and soldering test by dipping based on IEC 60068-2 for Pb-free solders are performed on each production lot as shown in the following chart. Test results and accompanying samples are retained for a minimum of two (2) years. The solderability of a specific lot can be checked at any time within this period should a customer require this information.

Test	Resistance to flux	Solderability	Static leaching (simulation of Reflow Soldering)	Dynamic leaching (simulation of Wave Soldering)
Parameter				
Soldering method	dipping	dipping	dipping	dipping with agitation
Flux	L3CN, ORLO	L3CN, ORLO, R	L3CN, ORLO, R	L3CN, ORLO, R
Pb Solder	62Sn / 36Pb / 2 Ag			
Pb Soldering temperature (°C)	235 ± 5	235 ± 5	260 ± 5	235 ± 5
Pb-FREE Solder	Sn96 / Cu0,4-0,8 / 3-4Ag			
Pb-FREE Soldering temperature (°C)	250 ± 5	250 ± 5	280 ± 5	250 ± 5
Soldering time (s)	2	210	10	> 15
Burn-in conditions	V _{dcmax} , 48 h	-	-	-
Acceptance criterion	dVn < 5 %, i _{dc} must stay unchanged	> 95 % of end termination must be covered by solder	> 95 % of end termination must be intact and covered by solder	> 95 % of end termination must be intact and covered by solder

Rework Criteria Soldering Iron – unless absolutely necessary, the use of soldering irons is NOT recommended for reworking varistor chips. If no other means of rework is available, the following criteria must be strictly followed:

- Do not allow the tip of the iron to directly contact the top of the chip
- Do not exceed the following soldering iron specifications:
 - Output Power: 30 Watts maximum
 - Temperature of Soldering Iron Tip: 280 °C maximum
 - Soldering Time: 10 Seconds maximum

Storage Conditions – SMD varistors should be used within 1 year of purchase to avoid possible soldering problems caused by oxidized terminals. The storage environment should be controlled, with humidity less than 40% and temperature between -25 and 45 °C. Varistor chips should always be stored in their original packaged unit.

Where varistor chips have been in storage for more than 1 year, and where there is evidence of solderability difficulties, KEKO-VARICON can “refresh” the terminations to eliminate these problems.

Terminology

Term	Symbol	Definition
Rated AC Voltage	V_{rms}	Maximum continuous sinusoidal AC voltage (<5% total harmonic distortion) which may be applied to the component under continuous operation conditions at 25 °C
Rated DC Voltage	V_{dc}	Maximum continuous DC voltage (<5% ripple) which may be applied to the component under continuous operating conditions at 25 °C
Supply Voltage	V	The voltage by which the system is designated and to which certain operating characteristics of the system are referred; $V_{rms} = 1,1 \times V$
Leakage Current	I_{dc}	The current passing through the varistor at V_{dc} and at 25 °C or at any other specified temperature
Varistor Voltage	V_n	Voltage across the varistor measured at a given reference current I_n
Reference Current	I_n	Reference current = 1 mA DC
Clamping Voltage Protection Level	V_c	The peak voltage developed across the varistor under standard atmospheric conditions, when passing an 8/20 μ s class current pulse
Class Current	I_c	A peak value of current which is 1/10 of the maximum peak current for 100 pulses at two per minute for the 8/20 μ s pulse
Voltage Clamping Ratio	V_c/V_{app}	A figure of merit measure of the varistor clamping effectiveness as defined by the symbols V_c/V_{app} , where ($V_{app} = V_{rms}$ or V_{dc})
Jump Start Transient	V_{jump}	The jump start transient results from the temporary application of an overvoltage in excess of the rated battery voltage. The circuit power supply may be subjected to a temporary overvoltage condition due to the voltage regulation failing or it may be deliberately generated when it becomes necessary to boost start the car.
Rated Single Pulse Transient Energy	W_{max}	Energy which may be dissipated for a single 10/1000 μ s pulse of a maximum rated current, with rated AC voltage or rated DC voltage also applied, without causing device failure
Load Dump Transient	WLD	Load Dump is a transient which occurs in automotive environment. It is an exponentially decaying positive voltage which occurs in the event of a battery disconnect while the alternator is still generating charging current with other loads remaining on the alternator circuit at the time of battery disconnect.
Rated Peak Single Pulse Transient Current	I_{max}	Maximum peak current which may be applied for a single 8/20 μ s pulse, with, rated line voltage also applies, without causing device failure
Rated Transient Average Power Dissipation	P	Maximum average power which may be dissipated due to a group of pulses occurring within a specified isolated time period, without causing device failure at 25 °C
Capacitance	C	Capacitance between two terminals of the varistor measured at @ 1 kHz
Non-linearity Exponent	α	A measure of varistor nonlinearity between two given operating currents, I_n and I_1 , as described by $I = k V \exp(a)$, where: - k is a device constant, - $I_1 < I < I_n$ and - $a = 0 \log(I_1/I_n) / \log(V_1/V_n) = 1 / \log(V_1/V_n)$, where: - I_n is reference current (1 mA) and V_n is varistor voltage - $I_1 = 10 I_n$, V_1 is the voltage measured at I_1
Response Time	t_r	The time lag between application of a surge and varistor's "turn-on" conduction action
Varistor Voltage Temperature Coefficient	TC	$(V_n \text{ at } 85 \text{ }^\circ\text{C} - V_n \text{ at } 25 \text{ }^\circ\text{C}) / (V_n \text{ at } 25 \text{ }^\circ\text{C}) \times 60 \text{ }^\circ\text{C} \times 100$
Insulation Resistance	IR	Minimum resistance between shorted terminals and varistor surface
Isolation Voltage		The maximum peak voltage which may be applied under continuous operating conditions between the varistor terminations and any conducting mounting surface
Operating Temperature		the range of ambient temperature for which the varistor is designed to operate continuously as defined by the temperature limits of its climatic category
Climatic Category	LCT/UCT/DHD	UCT = Upper Category Temperature - the maximum ambient temperature for which a varistor has been designed to operate continuously, LCT = Lower Category Temperature - the minimum ambient temperature at which a varistor has been designed to operate continuously DHD = Dump Heat Test Duration
Storage Temperature		Storage temperature range without voltage applied
Current/Energy Derating		Derating of maximum values when operated above UCT (85 °C for PV and 125 °C for DV)

KEKOVARICON

Grajski trg 15, SI-8360 Zuzemberk, SLOVENIA

Phone: + 386 7 3885 178

Fax: + 386 7 3885 166

E-mail: info@keko-varicon.si

All rights reserved/Copyright © 2015 KEKO VARICON d.o.o.

www.keko-varicon.si