

NPN Silicon Planar Power Transistor

160V_{CB0}, 10A I_c, TO-3

multicomp PRO

**RoHS
Compliant**



Description

This is High-power industrial transistor NPN silicon power transistor designed for applications in industrial and commercial equipment including high fidelity audio amplifiers, series and shunt regulators and power switches

Features

1. Higher safe operating area at VCE >40V
2. Low saturation voltages
3. High power dissipation capability

Applications:

For high power audio, series pass power supplies, disk-head positioners and other linear application. These devices can also be used in power switching circuits such as converters or inverters

Absolute Maximum Ratings (T_A = 25 °C)

Parameter	Symbol	Value	Unit
Collector-Base Voltage	V _{CB0}	160	V DC
Collector-Emitter Voltage	V _{CEO}	140	
Emitter-Base Voltage	V _{EB0}	7	
Collector Current-continuous	I _c	10	A
Collector Current-Peak	I _{CM}	15	
Base Current	I _B	7	
Total Power Dissipation @TC= 25°C	P _D	117	W
Total Power Dissipation Derate above @TC= 25°C		0.67	W/ °C
Operating and Storage Junction Temperature Range	T _J , T _{STG}	-65 to +200	°C

Thermal Characteristics

Parameter	Symbol	Value	Unit
Thermal Resistance Junction to Case	R _{θjc}	1.17	°C/W

Newark.com/multicomp-pro
Farnell.com/multicomp-pro
Element14.com/multicomp-pro

multicomp PRO

NPN Silicon Planar Power Transistor

160V_{CBO}, 10A I_c, TO-3

multicomp PRO

Electrical Characteristics at T_A = 25 °C unless otherwise specified

Parameter	Symbol	Test Conditions	Value		Unit
			Min.	Max.	
Off Characteristics					
Collector-Emitter Sustaining Voltage	V _{CEO(SUS)}	I _c = 200mA, I _B =0	140	-	V DC
Collector Cut-off Current	I _{CEO}	V _{CE} =140V, I _B =0	-	200	mA
Collector Cut-off Current	I _{CEX}	V _{CE} =140 V DC, V _{BE(off)} =1.5 V DC	-	5	
		V _{CE} =140V DC, mA V _{BE (off)} =1.5V DC, T _c =150°C	-	30	
Emitter Cut-off Current	I _{EBO}	V _{EB} = 7V DC, I _c = 0	-	5	
On Characteristics Note3.					
DC Current Gain	h _{FE}	I _c = 3A DC, V _{CE} = 4V DC)	2	70	
		I _c =10A DC, V _{CE} =4V DC	7.5	-	
Collector-Emitter Saturation Voltage	V _{CE(SAT)}	I _c = 10A DC, I _B = 2A DC	-	5	V DC
Base-Emitter On Voltage	V _{BE(SAT)}	I _c =10A DC, V _{CE} =4V DC	-	5.7	
Dynamic Characteristics					
Current-Gain - Bandwidth Product (Note 4)	f _T	I _c =2A DC, V _{CE} =4V DC, f _{TEST} = 40kHz	80	-	kHz
Small-Signal Current Gain	h _{FE}	I _c =2A DC, V _{CE} =4V DC, f=1kHz	12	72	

Note:

(3) Pulse Test : Pulse Width = 300μs, Duty Cycle ≤2%

(4) f_T = | h_{fe} | • f_{test}

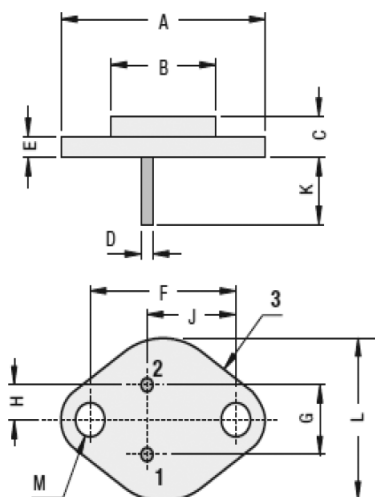

Din	Min	Max
A	-	40
B	-	25
C	6.35	11.43
D	0.70	1.09
E	-	3.8
F	29.90	30.40

Din	Min	Max
G	10.67	11.18
H	5.21	5.72
J	16.64	17.15
K	7.92	-
L	-	26.68
M	3.84	4.09

Newark.com/multicomp-pro
Farnell.com/multicomp-pro
Element14.com/multicomp-pro

multicomp PRO

NPN Silicon Planar Power Transistor

160V_{CEO}, 10A I_C, TO-3

multicomp PRO

Recommended Product Storage Environment for Diode and Transistors

This storage environment assumes that the Diodes and transistors are packed properly inside the original packing supplied by.

Temperature 5°C to 30°C

- Humidity between 40%RH to 70%RH
- Air should be clean.
- Avoid harmful gas or dust
- Avoid outdoor exposure or storage in areas subject to rain or water spraying .
- Avoid storage in areas subject to corrosive gas or dust. Product shall not be stored in areas exposed to direct sunlight.
- Avoid rapid change of temperature.
- Avoid condensation.
- Mechanical stress such as vibration and impact shall be avoided.
- The product shall not be placed directly on the floor.
- The product shall be stored on a plane area. They should not be turned upside down. They should not be placed against the wall.

Shelf Life of Products

The shelf life of products is the period from product manufacture to shipment to customers. The product can be unconditionally shipped within this period. The period is defined as 2 years.

If products are stored longer than the shelf life of 2 years, the products shall be subjected to quality check as per COIL quality procedure.

The products are further warranted for another one year after the date of shipment subject to the above conditions in COIL original packing.

Floor Life of Products and MSL Level

When the products are opened from the original packing, the floor life will start. For this the following JEDEC table may be referred:

JEDEC MSL Level		
Level	Time	Condition
1	Unlimited	≤30°C / 85% RH
2	1 Year	≤30°C / 60% RH
2a	4 Weeks	≤30°C / 60% RH
3	168 Hours	≤30 °C / 60% RH
4	72 Hours	≤30°C / 60% RH
5	48 Hours	≤30°C / 60% RH
Sa	24 Hours	≤30°C / 60% RH
6	Time on Label (TOL)	≤30°C / 60% RH

Part Number Table

Description	Part Number
NPN Silicon Planar Power Transistor, 160 V _{CEO} , 10A I _C , TO-3	2N3442

Important Notice : This data sheet and its contents (the "Information") belong to the members of the AVNET group of companies (the "Group") or are licensed to it. No licence is granted for the use of it other than for information purposes in connection with the products to which it relates. No licence of any intellectual property rights is granted. The Information is subject to change without notice and replaces all data sheets previously supplied. The Information supplied is believed to be accurate but the Group assumes no responsibility for its accuracy or completeness, any error in or omission from it or for any use made of it. Users of this data sheet should check for themselves the Information and the suitability of the products for their purpose and not make any assumptions based on information included or omitted. Liability for loss or damage resulting from any reliance on the Information or use of it (including liability resulting from negligence or where the Group was aware of the possibility of such loss or damage arising) is excluded. This will not operate to limit or restrict the Group's liability for death or personal injury resulting from its negligence. Multicomp Pro is the registered trademark of Premier Farnell Limited 2019.

Newark.com/multicomp-pro
Farnell.com/multicomp-pro
Element14.com/multicomp-pro

multicomp PRO