

backward curved, single inlet

with support bracket

**ebm-papst Mulfingen GmbH & Co. KG**

Bachmühle 2 · D-74673 Mulfingen

Phone +49 7938 81-0

Fax +49 7938 81-110

info1@de.ebmpapst.com

www.ebmpapst.com

Limited partnership · Headquarters Mulfingen

County court Stuttgart · HRA 590344

General partner Elektrobau Mulfingen GmbH · Headquarters Mulfingen

County court Stuttgart · HRB 590142

**Nominal data**

<b>Type</b>	<b>K3G560-PC04-05</b>	
<b>Motor</b>	<b>M3G150-NA</b>	
Phase		3~
Nominal voltage	VAC	400
Nominal voltage range	VAC	380 .. 480
Frequency	Hz	50/60
Type of data definition		ml
Speed (rpm)	min <sup>-1</sup>	1760
Power input	W	5000
Current draw	A	7.7
Min. ambient temperature	°C	-25
Max. ambient temperature	°C	40

ml = Max. load · me = Max. efficiency · fa = Running at free air · cs = Customer specs · cu = Customer unit  
Subject to alterations

**Data in accordance with ecodesign regulation EU 327/2011**

		Actual	Request 2015
01 Overall efficiency $\eta_{es}$	%	70.2	58.9
02 Measurement category		A	
03 Efficiency category		Static	
04 Efficiency grade N		73.3	62
05 Variable speed drive		Yes	

Data definition with optimum efficiency.

The ErP data is determined using a motor-impeller combination in a standardised measurement configuration.

09 Power input $P_{ed}$	kW	5.03
09 Air flow $q_v$	m <sup>3</sup> /h	11760
09 Pressure increase $p_{fs}$	Pa	1035
10 Speed (rpm) $n$	min <sup>-1</sup>	1770
11 Specific ratio*		1.01

\* Specific ratio =  $1 + p_{fs} / 100\,000\text{ Pa}$ 

LU-173565



## Technical features

<b>Mass</b>	64.8 kg
<b>Size</b>	560 mm
<b>Motor size</b>	150
<b>Surface of rotor</b>	Coated in black
<b>Material of electronics housing</b>	Die-cast aluminium
<b>Material of impeller</b>	Aluminium sheet
<b>Material of mounting plate</b>	Sheet steel, galvanised
<b>Material of support bracket</b>	Steel, coated in black
<b>Material of inlet nozzle</b>	Sheet steel, galvanised
<b>Number of blades</b>	5
<b>Direction of rotation</b>	Clockwise, seen on rotor
<b>Type of protection</b>	IP55
<b>Insulation class</b>	"F"
<b>Humidity (F) / environmental protection class (H)</b>	H1
<b>Max. permissible ambient motor temp. (transp./ storage)</b>	+80 °C
<b>Min. permissible ambient motor temp. (transp./storage)</b>	-40 °C
<b>Mounting position</b>	Refer to product drawing
<b>Condensation drainage holes</b>	Rotor-side
<b>Operation mode</b>	S1
<b>Motor bearing</b>	Ball bearing
<b>Technical features</b>	<ul style="list-style-type: none"> <li>- Output 10 VDC, max. 10 mA</li> <li>- Output 20 VDC, max. 50 mA</li> <li>- Output for slave 0-10 V</li> <li>- Operation and alarm display</li> <li>- Input for sensor 0-10 V or 4-20 mA</li> <li>- External 24 V input (programming)</li> <li>- External release input</li> <li>- Alarm relay</li> <li>- Integrated PID controller</li> <li>- Output limit</li> <li>- Motor current limit</li> <li>- PFC, passive</li> <li>- RS485 MODBUS RTU</li> <li>- Soft start</li> <li>- Control input 0-10 VDC / PWM</li> <li>- Control interface with SELV potential safely disconnected from the mains</li> <li>- Over-temperature protected electronics / motor</li> <li>- Line undervoltage / phase failure detection</li> </ul>
<b>EMC interference immunity</b>	Acc. to EN 61000-6-2 (industrial environment)
<b>EMC interference emission</b>	Acc. to EN 61000-6-3 (household environment), except EN 61000-3-2 for professionally used devices with a total rated power greater than 1 kW
<b>Touch current acc. IEC 60990 (measuring network Fig. 4, TN system)</b>	<= 3.5 mA
<b>Electrical connection</b>	Terminal box
<b>Motor protection</b>	Reverse polarity and locked-rotor protection

K3G560-PC04-05

## EC centrifugal module - RadiPac

backward curved, single inlet

with support bracket

<b>Protection class</b>	I (if protective earth is connected by customer)
<b>Product conforming to standard</b>	EN 61800-5-1; CE
<b>Approval</b>	CSA C22.2 no. 77 + CAN/CSA-E60730-1; EAC; UL 1004-7 + 60730-1



# EC centrifugal module - RadiPac

backward curved, single inlet  
with support bracket

## Product drawing

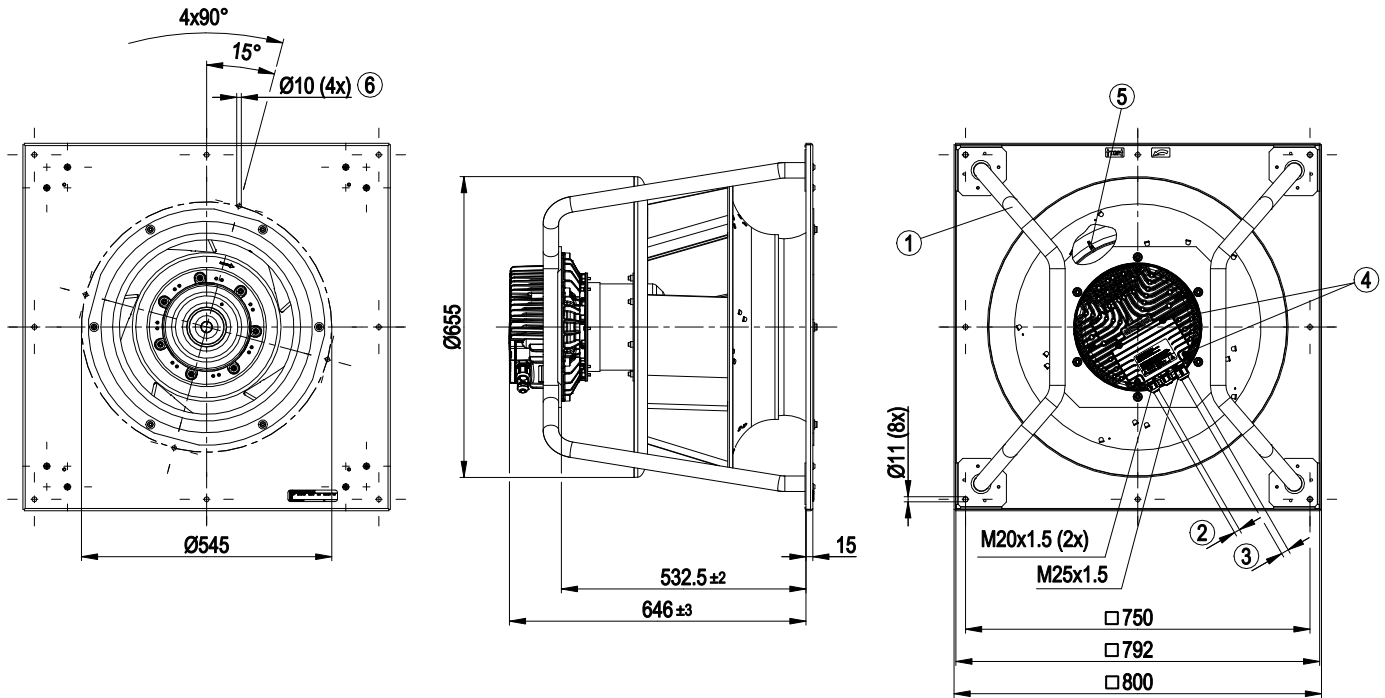

1	Installation position: Shaft horizontal (install the support struts only vertically as shown in the illustration!) or rotor on bottom; rotor on top on request
2	Cable diameter min. 4 mm, max. 10 mm, tightening torque $4 \pm 0.6$ Nm
3	Cable diameter min. 9 mm, max. 16 mm, tightening torque $6 \pm 0.9$ Nm
4	Tightening torque $3.5 \pm 0.5$ Nm
5	Inlet nozzle with pressure tap (k-factor: 348)
6	Mounting holes for FlowGrid

# EC centrifugal module - RadiPac

backward curved, single inlet  
with support bracket

## Connection screen

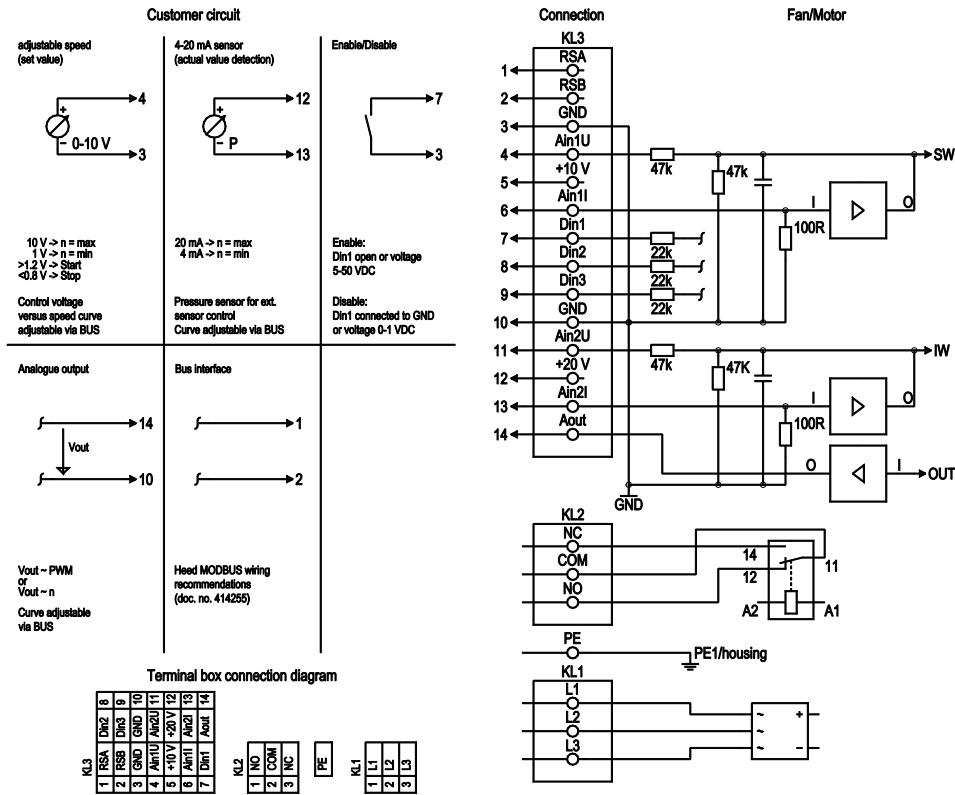

No.	Conn.	Designation	Function / assignment
KL 1	1	L1	Mains connection, power supply, phase, see type plate for voltage range
KL 1	2	L2	Mains connection, power supply, phase, see type plate for voltage range
KL 1	3	L3	Mains connection, power supply, phase, see type plate for voltage range
PE		PE	Earth connection, PE connection
KL 2	1	NO	Status relay, floating status contact, make for failure
KL 2	2	COM	Status relay, floating status contact, changeover contact, common connection, contact rating, max. 250 VAC/2 A (AC1)/min. 10 mA
KL 2	3	NC	Status relay, floating status contact, break for failure
KL 3	1	RSA	Bus connection RS485, RSA, MODBUS RTU; SELV
KL 3	2	RSB	Bus connection RS485, RSB, MODBUS RTU; SELV
KL 3	3 / 10	GND	Signal ground for control interface, SELV
KL 3	4	Ain1 U	Analogue input 1, set value: 0-10 V, Ri = 100 kΩ, parametrisable curve, only for use as alternative to input Ain1; SELV
KL 3	5	+ 10 V	Fixed voltage output 10 VDC, +10 V +/- 3 %, max. 10 mA, short-circuit-proof, power supply for ext. devices (e.g. potentiometer); SELV
KL 3	6	Ain1 I	Analogue input 1, set value: 4-20 mA; Ri = 100 Ω, parametrisable curve, only for use as alternative to input Ain1 U; SELV
KL 3	7	Din1	Digital input 1: Enabling of electronics, Enabling: Pin open or applied voltage 5-50 VDC Disabling: Bridge to GND or applied voltage <1 VDC Reset function: Triggers software reset after a level change to <1 VDC; SELV
KL 3	8	Din2	Digital input 2: Parameter set 1/2 switching, depending on EEPROM setting, the valid/used parameter set can be selected via the bus or via the digital input DIN2. Parameter set 1: Pin open or applied voltage 5-50 VDC Parameter set 2: bridge to GND or applied voltage <1 VDC; SELV



# EC centrifugal module - RadiPac

backward curved, single inlet

with support bracket

No.	Conn.	Designation	Function / assignment
KL 3	9	Din3	Digital input 3: Controller function of integrated controller; depending on EEPROM setting, normal / inverse can be selected for the controller function of the integrated controller via the bus or the digital input Normal: Pin open or applied voltage 5-50 VDC Inverse: bridge to GND or applied voltage <1 VDC; SELV
KL 3	11	Ain2 U	Analogue input 2, actual value: 0-10 V, Ri = 100 k $\Omega$ , parametrisable curve, only usable as alternative to input Ain2; SELV
KL 3	12	+ 20 V	Fixed voltage output 20 VDC, +20 V +25/-10%, max. 50 mA, short-circuit-proof, power supply for ext. devices (e.g. sensors); SELV Alternatively: +24 VDC input for parametrisation without mains power
KL 3	13	Ain2 I	Analogue input 2, actual value: 4-20 mA, Ri = 100 $\Omega$ , parametrisable curve, only for use as alternative to input Ain2 U; SELV
KL 3	14	Aout	Analogue output 0-10 V, max. 5 mA, output of current motor level control coefficient; parametrisable curve; SELV



# EC centrifugal module - RadiPac

backward curved, single inlet  
with support bracket

## Charts: Air flow 50 Hz

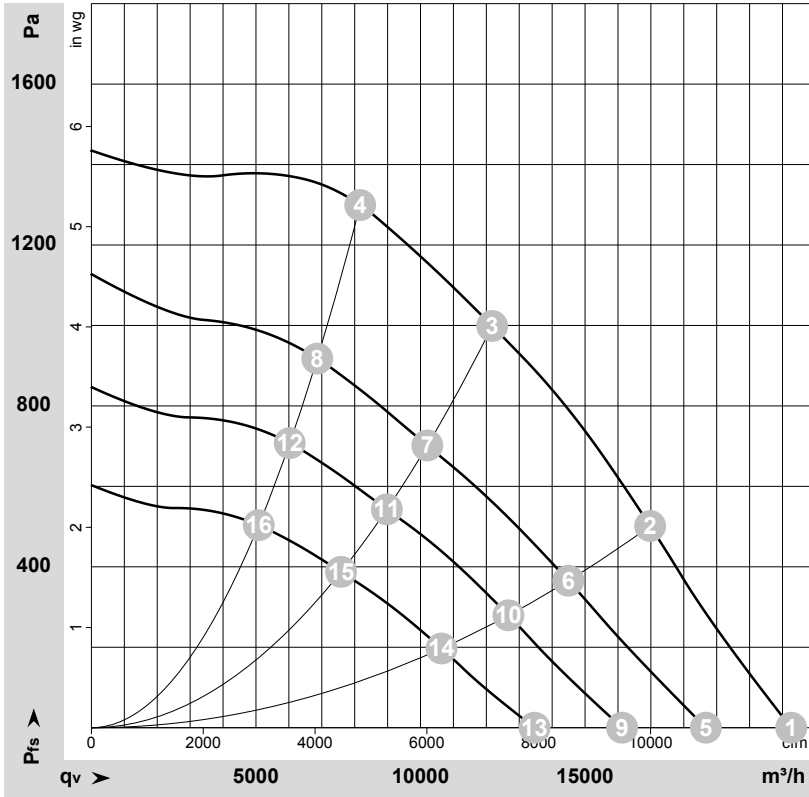

$\rho = 1.15 \text{ kg/m}^3 \pm 2 \%$

Measurement: LU-173565-1

Air performance measured as per ISO 5801 Installation category A. For detailed information on the measuring set-up, please contact ebmpapst. Suction-side noise levels: LwA measured as per ISO 13347 / LpA measured with 1m distance to fan axis. The values given are valid under the measuring conditions mentioned above and may vary according to the actual installation situation. With any deviation from the standard set-up, the specific values have to be checked and reviewed with the unit installed.

## Measured values

	U	f	n	P <sub>ed</sub>	I	LpA <sub>in</sub>	LwA <sub>in</sub>	LwA <sub>out</sub>	q <sub>v</sub>	P <sub>fs</sub>	q <sub>v</sub>	P <sub>fs</sub>
	V	Hz	min <sup>-1</sup>	W	A	dB(A)	dB(A)	dB(A)	m <sup>3</sup> /h	Pa	cfm	in. wg
1	400	50	1760	2788	4.36	95	101	101	21265	0	12515	0.00
2	400	50	1760	4251	6.52	85	92	94	16980	500	9995	2.01
3	400	50	1760	5000	7.70	77	84	89	12180	1000	7170	4.01
4	400	50	1760	4788	7.32	80	87	92	8165	1300	4805	5.22
5	400	50	1575	1956	3.17	90	97	96	18670	0	10990	0.00
6	400	50	1510	2650	4.16	80	88	90	14495	368	8530	1.48
7	400	50	1480	2956	4.61	73	79	85	10205	701	6010	2.81
8	400	50	1490	2845	4.45	75	82	88	6865	920	4040	3.69
9	400	50	1365	1306	2.29	85	93	93	16125	0	9490	0.00
10	400	50	1325	1802	2.96	78	85	87	12670	281	7460	1.13
11	400	50	1305	2023	3.27	70	77	82	8980	543	5285	2.18
12	400	50	1310	1937	3.15	72	80	85	6025	709	3545	2.85
13	400	50	1145	827	1.58	81	89	90	13465	0	7925	0.00
14	400	50	1115	1113	2.04	73	80	83	10640	199	6260	0.80
15	400	50	1100	1271	2.25	65	72	77	7585	388	4465	1.56
16	400	50	1105	1212	2.17	67	74	79	5085	505	2990	2.03

U = Supply voltage · f = Frequency · n = Speed (rpm) · P<sub>ed</sub> = Power input · I = Current draw · LpA<sub>in</sub> = Sound pressure level inlet side · LwA<sub>in</sub> = Sound power level inlet side · LwA<sub>out</sub> = Sound power level outlet side  
q<sub>v</sub> = Air flow · P<sub>fs</sub> = Pressure increase

