

backward curved, single inlet

with support bracket

**ebm-papst Mulfingen GmbH & Co. KG**

Bachmühle 2 · D-74673 Mulfingen

Phone +49 7938 81-0

Fax +49 7938 81-110

info1@de.ebmpapst.com

www.ebmpapst.com

Limited partnership · Headquarters Mulfingen

County court Stuttgart · HRA 590344

General partner Elektrobau Mulfingen GmbH · Headquarters Mulfingen

County court Stuttgart · HRB 590142

**Nominal data**

|                          |                       |            |
|--------------------------|-----------------------|------------|
| <b>Type</b>              | <b>K3G450-PB24-05</b> |            |
| <b>Motor</b>             | <b>M3G150-IF</b>      |            |
| Phase                    |                       | 3~         |
| Nominal voltage          | VAC                   | 400        |
| Nominal voltage range    | VAC                   | 380 .. 480 |
| Frequency                | Hz                    | 50/60      |
| Type of data definition  |                       | ml         |
| Speed (rpm)              | min <sup>-1</sup>     | 2600       |
| Power input              | W                     | 5250       |
| Current draw             | A                     | 8          |
| Min. ambient temperature | °C                    | -25        |
| Max. ambient temperature | °C                    | 50         |

ml = Max. load · me = Max. efficiency · fa = Running at free air · cs = Customer specs · cu = Customer unit  
Subject to alterations

**Data in accordance with ecodesign regulation EU 327/2011**

|                                   |   | Actual | Request 2015 |
|-----------------------------------|---|--------|--------------|
| 01 Overall efficiency $\eta_{es}$ | % | 69.2   | 59           |
| 02 Measurement category           |   | A      |              |
| 03 Efficiency category            |   | Static |              |
| 04 Efficiency grade N             |   | 72.2   | 62           |
| 05 Variable speed drive           |   | Yes    |              |

Data definition with optimum efficiency.

The ErP data is determined using a motor-impeller combination in a standardised measurement configuration.

|                               |                   |      |
|-------------------------------|-------------------|------|
| 09 Power input $P_{ed}$       | kW                | 5.22 |
| 09 Air flow $q_v$             | m <sup>3</sup> /h | 7865 |
| 09 Pressure increase $p_{fs}$ | Pa                | 1606 |
| 10 Speed (rpm) $n$            | min <sup>-1</sup> | 2620 |
| 11 Specific ratio*            |                   | 1.02 |

\* Specific ratio =  $1 + p_{fs} / 100\,000\text{ Pa}$ 

LU-176459



backward curved, single inlet  
with support bracket

## Technical features

|  |   |
|--|---|
| Mass   | 48.2 kg   |
| Size   | 450 mm  |
| Motor size   | 150   |
| Surface of rotor   | Coated in black   |
| Material of electronics housing                                    | Die-cast aluminium  |
| Material of impeller   | Aluminium sheet   |
| Material of mounting plate   | Sheet steel, galvanised   |
| Material of support bracket  | Steel, coated in black  |
| Material of inlet nozzle   | Sheet steel, galvanised   |
| Number of blades   | 5   |
| Direction of rotation  | Clockwise, seen on rotor  |
| Type of protection   | IP55  |
| Insulation class   | "F"   |
| Humidity (F) / environmental protection class (H)                  | H1  |
| Max. permissible ambient motor temp. (transp./ storage)            | +80 °C  |
| Min. permissible ambient motor temp. (transp./storage)             | -40 °C  |
| Mounting position  | Refer to product drawing  |
| Condensation drainage holes  | Rotor-side  |
| Operation mode   | S1  |
| Motor bearing  | Ball bearing  |
| Technical features   | <ul style="list-style-type: none"> <li>- Output 10 VDC, max. 10 mA</li> <li>- Output 20 VDC, max. 50 mA</li> <li>- Output for slave 0-10 V</li> <li>- Operation and alarm display</li> <li>- Input for sensor 0-10 V or 4-20 mA</li> <li>- External 24 V input (programming)</li> <li>- External release input</li> <li>- Alarm relay</li> <li>- Integrated PID controller</li> <li>- Output limit</li> <li>- Motor current limit</li> <li>- PFC, passive</li> <li>- RS485 MODBUS RTU</li> <li>- Soft start</li> <li>- Control input 0-10 VDC / PWM</li> <li>- Control interface with SELV potential safely disconnected from the mains</li> <li>- Over-temperature protected electronics / motor</li> <li>- Line undervoltage / phase failure detection</li> </ul> |
| EMC interference immunity  | Acc. to EN 61000-6-2 (industrial environment)   |
| EMC interference emission  | Acc. to EN 61000-6-3 (household environment), except EN 61000-3-2 for professionally used devices with a total rated power greater than 1 kW  |
| Touch current acc. IEC 60990 (measuring network Fig. 4, TN system) | <= 3.5 mA   |
| Electrical connection  | Terminal box  |
| Motor protection   | Reverse polarity and locked-rotor protection  |

K3G450-PB24-05

## EC centrifugal module - RadiPac

backward curved, single inlet

with support bracket

|                                       |   |
|---------------------------------------|---|
| <b>Protection class</b>               | I (if protective earth is connected by customer)              |
| <b>Product conforming to standard</b> | EN 61800-5-1; CE  |
| <b>Approval</b>                       | CSA C22.2 no. 77 + CAN/CSA-E60730-1; EAC; UL 1004-7 + 60730-1 |



# EC centrifugal module - RadiPac

backward curved, single inlet  
with support bracket

## Product drawing

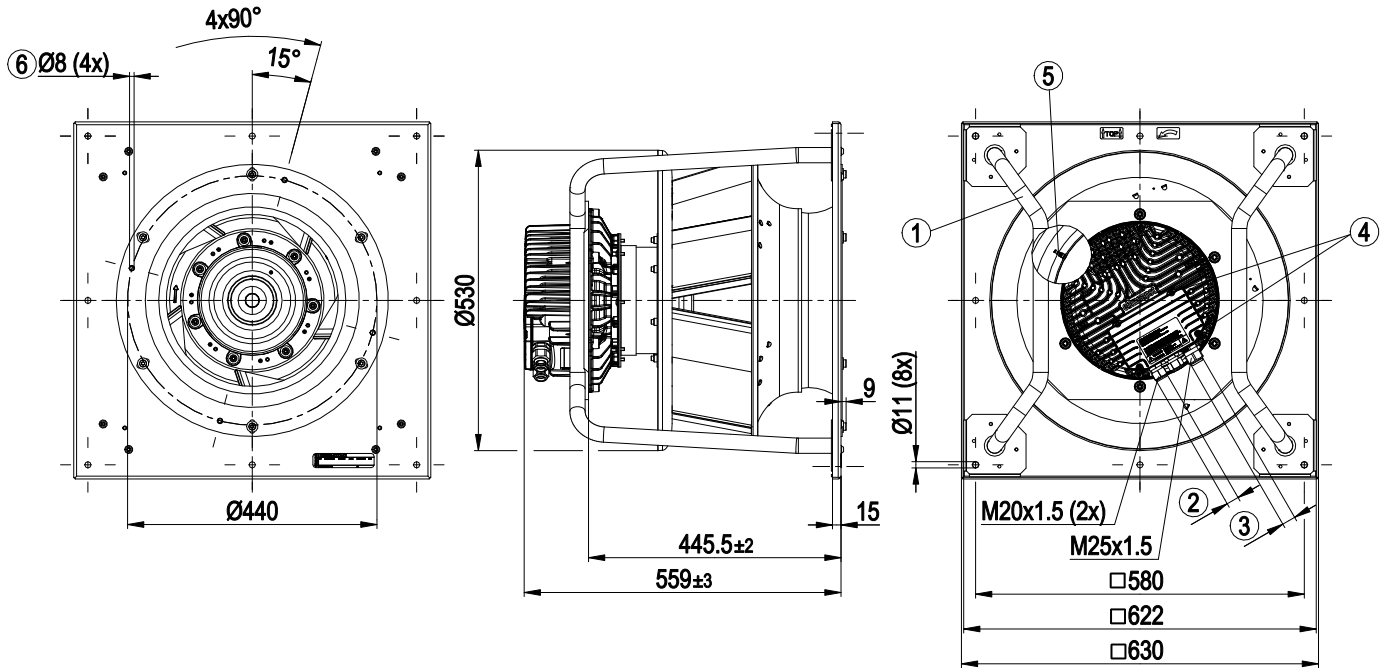

|   |  |
|---|--|
| 1 | Installation position: Shaft horizontal (install the support struts only vertically as shown in the illustration!) or rotor on bottom; rotor on top on request |
| 2 | Cable diameter min. 4 mm, max. 10 mm, tightening torque 4±0.6 Nm   |
| 3 | Cable diameter min. 9 mm, max. 16 mm, tightening torque 6±0.9 Nm   |
| 4 | Tightening torque 3.5±0.5 Nm   |
| 5 | Inlet nozzle with pressure tap (k-factor: 240)   |
| 6 | Mounting holes for FlowGrid  |



backward curved, single inlet  
with support bracket

## Connection screen

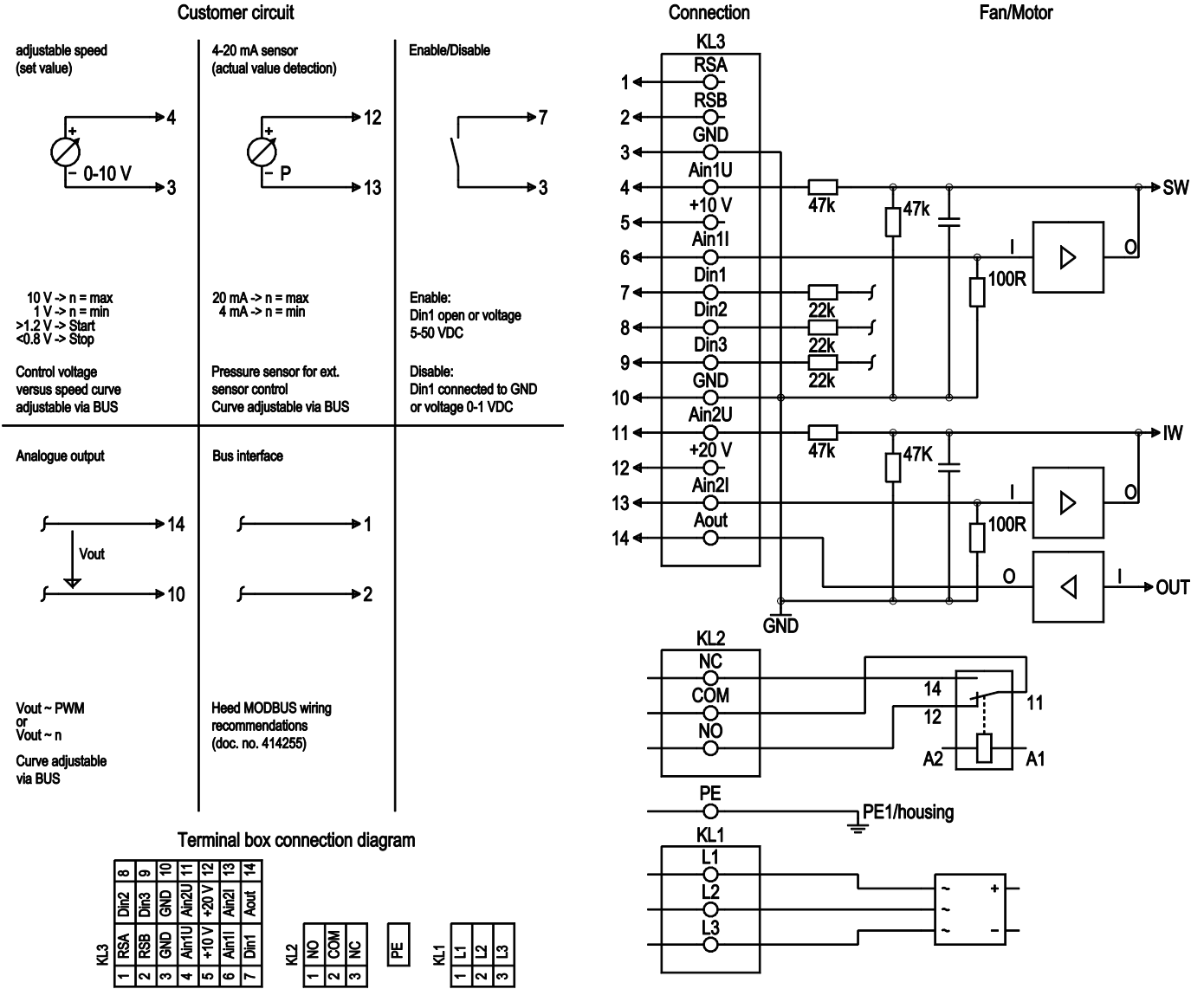

| No.  | Conn.  | Designation | Function / assignment   |
|------|--------|-------------|---|
| KL 1 | 1      | L1          | Mains connection, power supply, phase, see type plate for voltage range   |
| KL 1 | 2      | L2          | Mains connection, power supply, phase, see type plate for voltage range   |
| KL 1 | 3      | L3          | Mains connection, power supply, phase, see type plate for voltage range   |
| PE   |        | PE          | Earth connection, PE connection   |
| KL 2 | 1      | NO          | Status relay, floating status contact, make for failure   |
| KL 2 | 2      | COM         | Status relay, floating status contact, changeover contact, common connection, contact rating, max. 250 VAC/2 A (AC1)/min. 10 mA |
| KL 2 | 3      | NC          | Status relay, floating status contact, break for failure  |
| KL 3 | 1      | RSA         | Bus connection RS485, RSA, MODBUS RTU; SELV   |
| KL 3 | 2      | RSB         | Bus connection RS485, RSB, MODBUS RTU; SELV   |
| KL 3 | 3 / 10 | GND         | Signal ground for control interface, SELV   |
| KL 3 | 4      | Ain1 U      | Analogue input 1, set value: 0-10 V, Ri = 100 kΩ, parametrisable curve, only for use as alternative to input Ain1; SELV         |



# EC centrifugal module - RadiPac

backward curved, single inlet

with support bracket

| No.  | Conn. | Designation | Function / assignment  |
|------|-------|-------------|--|
| KL 3 | 5     | + 10 V      | Fixed voltage output 10 VDC, +10 V +/-3 %, max. 10 mA, short-circuit-proof, power supply for ext. devices (e.g. potentiometer); SELV   |
| KL 3 | 6     | Ain1 I      | Analogue input 1, set value: 4-20 mA; Ri = 100 Ω, parametrisable curve, only for use as alternative to input Ain1 U; SELV  |
| KL 3 | 7     | Din1        | Digital input 1: Enabling of electronics,<br>Enabling: Pin open or applied voltage 5-50 VDC<br>Disabling: Bridge to GND or applied voltage <1 VDC<br>Reset function: Triggers software reset after a level change to <1 VDC; SELV  |
| KL 3 | 8     | Din2        | Digital input 2: Parameter set 1/2 switching, depending on EEPROM setting, the valid/used parameter set can be selected via the bus or via the digital input DIN2.<br>Parameter set 1: Pin open or applied voltage 5-50 VDC<br>Parameter set 2: bridge to GND or applied voltage <1 VDC; SELV                                    |
| KL 3 | 9     | Din3        | Digital input 3: Controller function of integrated controller; depending on EEPROM setting, normal / inverse can be selected for the controller function of the integrated controller via the bus or the digital input<br>Normal: Pin open or applied voltage 5-50 VDC<br>Inverse: bridge to GND or applied voltage <1 VDC; SELV |
| KL 3 | 11    | Ain2 U      | Analogue input 2, actual value: 0-10 V, Ri = 100 kΩ, parametrisable curve, only usable as alternative to input Ain2; SELV  |
| KL 3 | 12    | + 20 V      | Fixed voltage output 20 VDC, +20 V +25/-10%, max. 50 mA, short-circuit-proof, power supply for ext. devices (e.g. sensors); SELV<br>Alternatively: +24 VDC input for parametrisation without mains power   |
| KL 3 | 13    | Ain2 I      | Analogue input 2, actual value: 4-20 mA, Ri = 100 Ω, parametrisable curve, only for use as alternative to input Ain2 U; SELV   |
| KL 3 | 14    | Aout        | Analogue output 0-10 V, max. 5 mA, output of current motor level control coefficient; parametrisable curve; SELV   |



# EC centrifugal module - RadiPac

backward curved, single inlet  
with support bracket

## Charts: Air flow 50 Hz

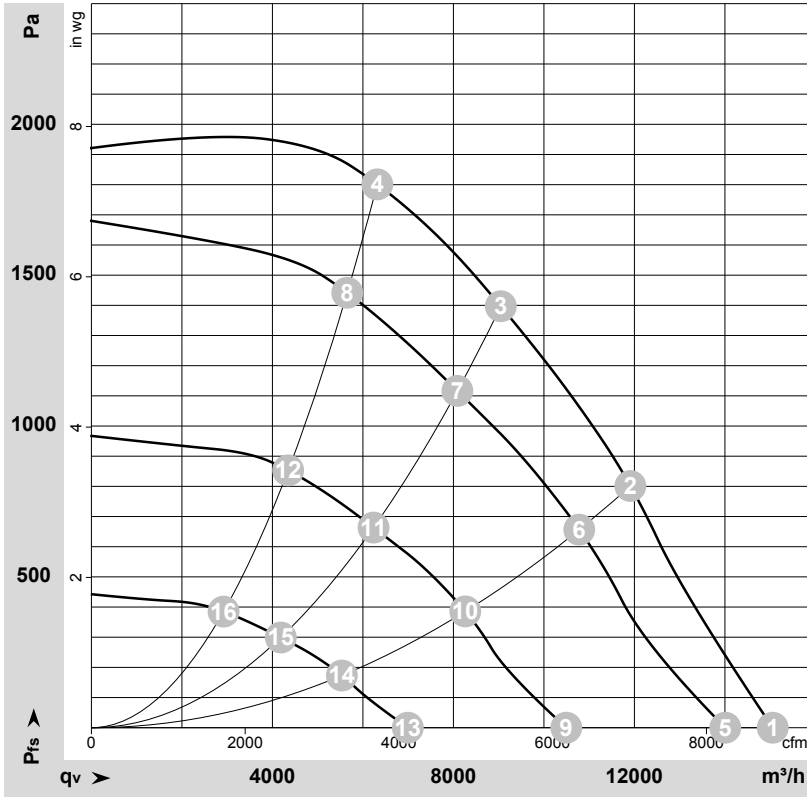

$$\rho = 1.15 \text{ kg/m}^3 \pm 2 \%$$

Measurement: LU-176459-1

Air performance measured as per ISO 5801 Installation category A. For detailed information on the measuring set-up, please contact ebmpapst. Suction-side noise levels: LwA measured as per ISO 13347 / LpA measured with 1m distance to fan axis. The values given are valid under the measuring conditions mentioned above and may vary according to the actual installation situation. With any deviation from the standard set-up, the specific values have to be checked and reviewed with the unit installed.

## Measured values

|    | U   | f  | n                 | P <sub>ed</sub> | I    | LpA <sub>in</sub> | LwA <sub>in</sub> | LwA <sub>out</sub> | q <sub>v</sub>    | P <sub>fs</sub> | q <sub>v</sub> | P <sub>fs</sub> |
|----|-----|----|-------------------|-----------------|------|-------------------|-------------------|--------------------|-------------------|-----------------|----------------|-----------------|
|    | V   | Hz | min <sup>-1</sup> | W               | A    | dB(A)             | dB(A)             | dB(A)              | m <sup>3</sup> /h | Pa              | cfm            | in. wg          |
| 1  | 400 | 50 | 2600              | 3067            | 4.78 | 95                | 102               | 102                | 15055             | 0               | 8860           | 0.00            |
| 2  | 400 | 50 | 2600              | 4640            | 7.13 | 85                | 92                | 97                 | 11910             | 800             | 7010           | 3.21            |
| 3  | 400 | 50 | 2600              | 5250            | 8.00 | 80                | 87                | 96                 | 9045              | 1400            | 5325           | 5.62            |
| 4  | 400 | 50 | 2600              | 5141            | 7.89 | 84                | 91                | 97                 | 6320              | 1800            | 3720           | 7.23            |
| 5  | 400 | 50 | 2430              | 2502            | 3.95 | 92                | 99                | 100                | 14010             | 0               | 8245           | 0.00            |
| 6  | 400 | 50 | 2360              | 3460            | 5.36 | 82                | 89                | 96                 | 10780             | 660             | 6345           | 2.65            |
| 7  | 400 | 50 | 2335              | 3767            | 5.81 | 77                | 84                | 95                 | 8090              | 1117            | 4760           | 4.48            |
| 8  | 400 | 50 | 2345              | 3677            | 5.68 | 80                | 87                | 95                 | 5655              | 1445            | 3325           | 5.80            |
| 9  | 400 | 50 | 1840              | 1122            | 2.04 | 84                | 92                | 94                 | 10495             | 0               | 6175           | 0.00            |
| 10 | 400 | 50 | 1815              | 1598            | 2.67 | 75                | 82                | 90                 | 8260              | 388             | 4865           | 1.56            |
| 11 | 400 | 50 | 1800              | 1761            | 2.89 | 71                | 78                | 89                 | 6235              | 663             | 3670           | 2.66            |
| 12 | 400 | 50 | 1805              | 1708            | 2.82 | 74                | 81                | 89                 | 4350              | 855             | 2560           | 3.43            |
| 13 | 400 | 50 | 1235              | 402             | 0.84 | 74                | 81                | 85                 | 6990              | 0               | 4115           | 0.00            |
| 14 | 400 | 50 | 1215              | 543             | 1.08 | 64                | 71                | 77                 | 5535              | 176             | 3260           | 0.71            |
| 15 | 400 | 50 | 1210              | 594             | 1.17 | 62                | 69                | 76                 | 4185              | 299             | 2465           | 1.20            |
| 16 | 400 | 50 | 1210              | 574             | 1.14 | 64                | 71                | 77                 | 2920              | 386             | 1720           | 1.55            |

U = Supply voltage · f = Frequency · n = Speed (rpm) · P<sub>ed</sub> = Power input · I = Current draw · LpA<sub>in</sub> = Sound pressure level inlet side · LwA<sub>in</sub> = Sound power level inlet side · LwA<sub>out</sub> = Sound power level outlet side  
q<sub>v</sub> = Air flow · P<sub>fs</sub> = Pressure increase

