

# EC centrifugal module - RadiPac

backward curved, single inlet

with support bracket

## ebm-papst Mulfingen GmbH & Co. KG

Bachmühle 2 · D-74673 Mulfingen

Phone +49 7938 81-0

Fax +49 7938 81-110

info1@de.ebmpapst.com

www.ebmpapst.com

Limited partnership · Headquarters Mulfingen

County court Stuttgart · HRA 590344

General partner Elektrobau Mulfingen GmbH · Headquarters Mulfingen

County court Stuttgart · HRB 590142

## Nominal data

Type	K3G280-PR04-I5	
Motor	M3G084-DF	
Phase		1~
Nominal voltage	VAC	230
Nominal voltage range	VAC	200 .. 277
Frequency	Hz	50/60
Type of data definition		ml
Speed (rpm)	min <sup>-1</sup>	3000
Power input	W	750
Current draw	A	3.3
Min. ambient temperature	°C	-25
Max. ambient temperature	°C	45

ml = Max. load · me = Max. efficiency · fa = Running at free air · cs = Customer specs · cu = Customer unit  
Subject to alterations

## Data in accordance with ecodesign regulation EU 327/2011

		Actual	Request 2015
01 Overall efficiency $\eta_{es}$	%	67.6	50
02 Measurement category		A	
03 Efficiency category		Static	
04 Efficiency grade N		79.6	62
05 Variable speed drive		Yes	

Data definition with optimum efficiency.

The ErP data is determined using a motor-impeller combination in a standardised measurement configuration.

09 Power input $P_{ed}$	kW	0.72
09 Air flow $q_v$	m <sup>3</sup> /h	2400
09 Pressure increase $p_{fs}$	Pa	665
10 Speed (rpm) $n$	min <sup>-1</sup>	2990
11 Specific ratio*		1.01

\* Specific ratio =  $1 + p_{fs} / 100\,000\text{ Pa}$ 

LU-173985



## Technical features

Mass	9.3 kg
Size	280 mm
Motor size	84
Surface of rotor	Coated in black
Material of terminal box	PP plastic
Material of electronics housing	Die-cast aluminium
Material of impeller	PP plastic
Material of mounting plate	Sheet steel, galvanised
Material of support bracket	Steel, coated in black
Material of inlet nozzle	Sheet steel, galvanised
Number of blades	6
Direction of rotation	Clockwise, seen on rotor
Type of protection	IP55
Insulation class	"F"
Humidity (F) / environmental protection class (H)	H1
Max. permissible ambient motor temp. (transp./ storage)	+80 °C
Min. permissible ambient motor temp. (transp./storage)	-40 °C
Mounting position	Shaft horizontal or rotor on bottom; rotor on top on request
Condensation drainage holes	Rotor-side
Operation mode	S1
Motor bearing	Ball bearing
Technical features	<ul style="list-style-type: none"> <li>- Output 10 VDC, max. 10 mA</li> <li>- Operation and alarm display</li> <li>- Alarm relay</li> <li>- Integrated PID controller</li> <li>- Output limit</li> <li>- Motor current limit</li> <li>- PFC, active</li> <li>- RS485 MODBUS RTU</li> <li>- Soft start</li> <li>- Control input 0-10 VDC / PWM</li> <li>- Control interface with SELV potential safely disconnected from the mains</li> <li>- Over-temperature protected electronics / motor</li> <li>- Line undervoltage / phase failure detection</li> </ul>
EMC interference immunity	Acc. to EN 61000-6-2 (industrial environment)
EMC harmonics	Acc. to EN 61000-3-2/3
EMC interference emission	Acc. to EN 61000-6-3 (household environment)
Touch current acc. IEC 60990 (measuring network Fig. 4, TN system)	<= 3.5 mA
Electrical connection	Terminal box
Motor protection	Thermal overload protector (TOP) wired internally
Cable exit	Variable
Protection class	I (if protective earth is connected by customer)
Product conforming to standard	EN 61800-5-1; CE
Approval	CSA C22.2 no. 77 + CAN/CSA-E60730-1; CCC; UL 1004-7 + 60730

# EC centrifugal module - RadiPac

backward curved, single inlet  
with support bracket

## Product drawing

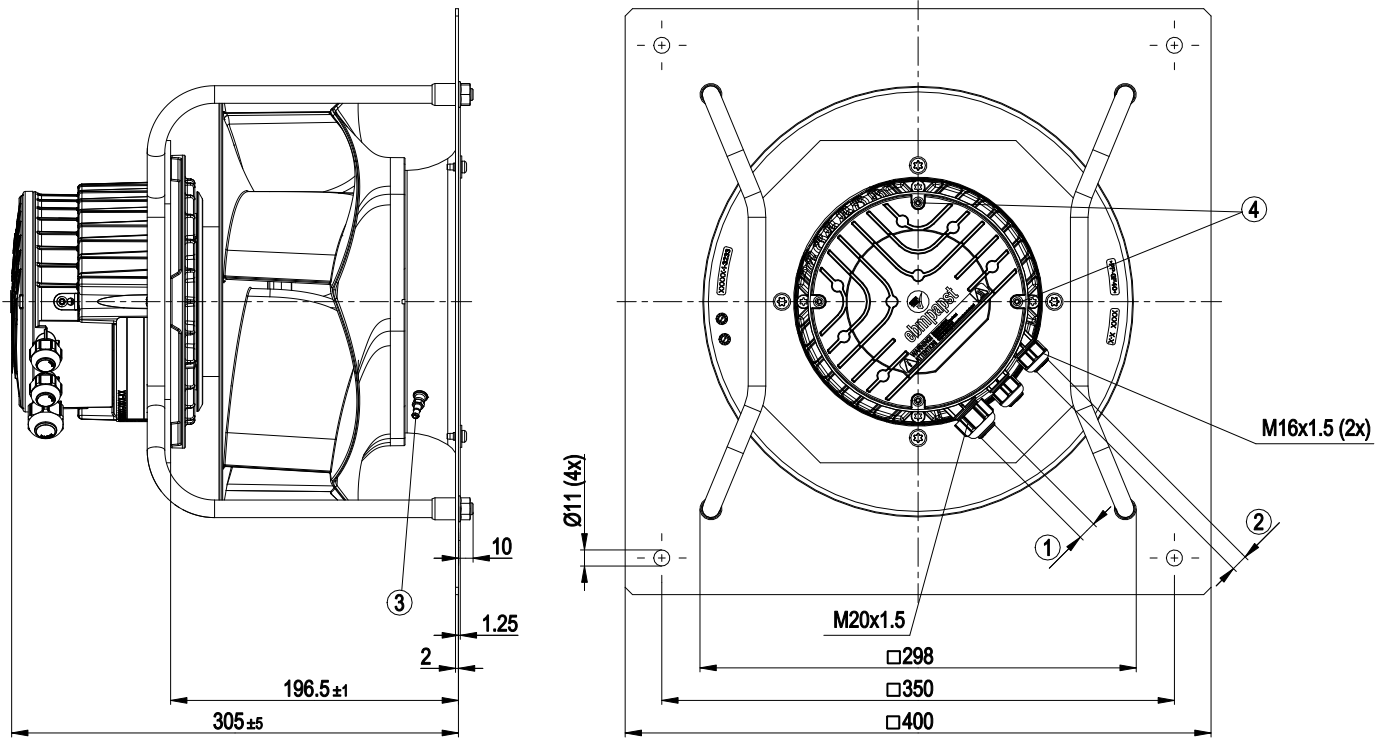

1	Cable diameter min. 8 mm, max. 12 mm, tightening torque $1.8 \pm 0.3$ Nm (use the provided seal) Cable diameter min. 4 mm, max. 10 mm, tightening torque $1.8 \pm 0.3$ Nm
2	Cable diameter min. 6 mm, max. 10 mm, tightening torque $1.8 \pm 0.3$ Nm (use the provided seal) Cable diameter min. 4 mm, max. 7 mm, tightening torque $1.8 \pm 0.3$ Nm
3	Inlet nozzle 28004-2-4013 with pressure tap (k-factor: 77)
4	Tightening torque $1.5 \pm 0.2$ Nm

# EC centrifugal module - RadiPac

backward curved, single inlet  
with support bracket

## Connection screen

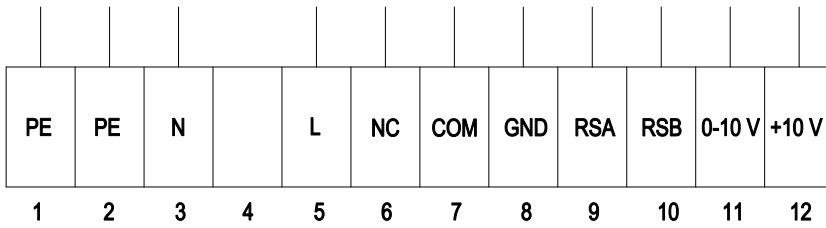

No.	Conn.	Designation	Function / assignment
1	PE	PE	Protective earth
2	PE	PE	Protective earth
3	N	N	Power supply, neutral conductor
4	-	-	not used
5	L	L	Power supply, phase
6	NC	NC	Status relay, floating status contact, break for failure, contact rating 250 VAC / 2 A (AC1) min. 10 mA, basic insulation on mains side and reinforced insulation on control interface side
7	COM	COM	Status relay, floating status contact, common connection, contact rating 250 VAC / 2 A (AC1) / min. 10 mA, basic insulation on mains side and reinforced insulation on control interface side
8	GND	GND	Signal ground for control interface, SELV
9	RSA	RSA	RS-485 interface for MODBUS, RSA; SELV
10	RSB	RSB	RS-485 interface for MODBUS, RSB; SELV
11	0-10 V	0-10 V	Analogue input (set value) SELV, 0-10 V, Ri=100kΩ, parametrisable curve
12	+10 V	+10 V	Fixed voltage output 10 VDC, SELV, +10 V ±3%, max. 10 mA, short-circuit-proof, power supply for external devices (e.g. potentiometer)



# EC centrifugal module - RadiPac

backward curved, single inlet  
with support bracket

## Charts: Air flow 50 Hz

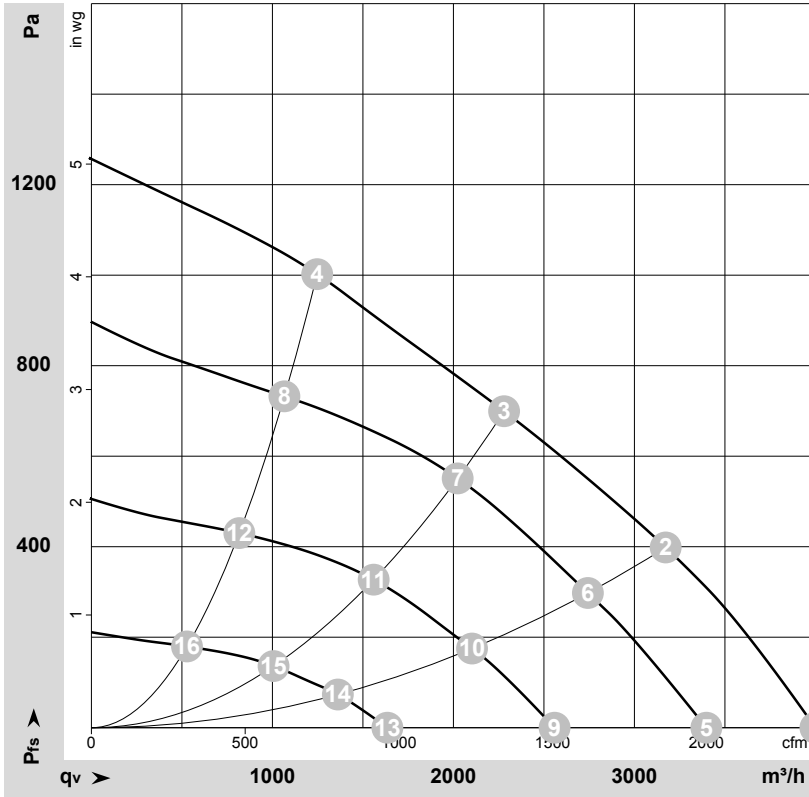

$\rho = 1.15 \text{ kg/m}^3 \pm 2 \%$

Measurement: LU-173985-1

Air performance measured as per ISO 5801 Installation category A. For detailed information on the measuring set-up, please contact ebmpapst. Suction-side noise levels: L<sub>wA</sub> measured as per ISO 13347 / L<sub>pA</sub> measured with 1m distance to fan axis. The values given are valid under the measuring conditions mentioned above and may vary according to the actual installation situation. With any deviation from the standard set-up, the specific values have to be checked and reviewed with the unit installed.

## Measured values

	U	f	n	P <sub>ed</sub>	I	L <sub>pA<sub>in</sub></sub>	L <sub>wA<sub>in</sub></sub>	q <sub>v</sub>	P <sub>fs</sub>	q <sub>v</sub>	P <sub>fs</sub>
	V	Hz	min <sup>-1</sup>	W	A	dB(A)	dB(A)	m³/h	Pa	cfm	in. wg
1	230	50	3260	642	2.81	80	87	4000	0	2355	0.00
2	230	50	3115	729	3.18	74	82	3175	400	1870	1.61
3	230	50	3000	750	3.30	69	77	2280	700	1340	2.81
4	230	50	3180	722	3.15	75	82	1245	1000	735	4.01
5	230	50	2780	404	1.79	75	83	3395	0	2000	0.00
6	230	50	2695	470	2.07	69	77	2745	298	1615	1.20
7	230	50	2660	509	2.24	65	73	2025	552	1190	2.22
8	230	50	2710	456	2.01	70	77	1065	732	625	2.94
9	230	50	2100	186	0.85	68	75	2560	0	1505	0.00
10	230	50	2070	227	1.02	62	70	2105	175	1240	0.70
11	230	50	2050	243	1.09	58	65	1560	328	920	1.32
12	230	50	2080	213	0.96	61	69	815	430	480	1.73
13	230	50	1355	63	0.37	58	66	1635	0	960	0.00
14	230	50	1335	75	0.41	53	61	1360	75	800	0.30
15	230	50	1330	79	0.43	49	56	1005	136	590	0.55
16	230	50	1345	71	0.40	53	58	530	180	310	0.72

U = Supply voltage · f = Frequency · n = Speed (rpm) · P<sub>ed</sub> = Power input · I = Current draw · L<sub>pA<sub>in</sub></sub> = Sound pressure level inlet side · L<sub>wA<sub>in</sub></sub> = Sound power level inlet side · q<sub>v</sub> = Air flow  
P<sub>fs</sub> = Pressure increase

