

**ebm-papst Mulfingen GmbH & Co. KG**

Bachmühle 2 · D-74673 Mulfingen

Phone +49 7938 81-0

Fax +49 7938 81-110

info1@de.ebmpapst.com

www.ebmpapst.com

Limited partnership · Headquarters Mulfingen

County court Stuttgart · HRA 590344

General partner Elektrobau Mulfingen GmbH · Headquarters Mulfingen

County court Stuttgart · HRB 590142

**Nominal data**

<b>Type</b>	<b>K3G250-PR17-I5</b>	
<b>Motor</b>	<b>M3G084-DF</b>	
Phase		1~
Nominal voltage	VAC	230
Nominal voltage range	VAC	200 .. 277
Frequency	Hz	50/60
Type of data definition		ml
Speed (rpm)	min <sup>-1</sup>	3450
Power input	W	750
Current draw	A	3.3
Min. ambient temperature	°C	-40
Max. ambient temperature	°C	45

ml = Max. load · me = Max. efficiency · fa = Running at free air · cs = Customer specs · cu = Customer unit  
Subject to alterations

**Data in accordance with ecodesign regulation EU 327/2011**

		Actual	Request 2015		
01 Overall efficiency $\eta_{es}$	%	67	49.9	09 Power input $P_{ed}$	kW 0.71
02 Measurement category		A		09 Air flow $q_v$	m <sup>3</sup> /h 2110
03 Efficiency category		Static		09 Pressure increase $p_{fs}$	Pa 749
04 Efficiency grade N		79.1	62	10 Speed (rpm) n	min <sup>-1</sup> 3395
05 Variable speed drive		Yes		11 Specific ratio*	1.01

Data definition with optimum efficiency.

The ErP data is determined using a motor-impeller combination in a standardised measurement configuration.

\* Specific ratio =  $1 + p_{fs} / 100\,000\text{ Pa}$ 

LU-174661



## Technical features

Mass	9.2 kg
Size	250 mm
Motor size	84
Surface of rotor	Coated in black
Material of terminal box	PP plastic
Material of electronics housing	Die-cast aluminium
Material of impeller	PP plastic
Material of mounting plate	Sheet steel, galvanised
Material of support bracket	Steel, coated in black
Material of inlet nozzle	Sheet steel, galvanised
Number of blades	6
Direction of rotation	Clockwise, seen on rotor
Type of protection	IP55
Insulation class	"F"
Humidity (F) / environmental protection class (H)	H1
Note ambient temperature	Occasional start-up between -40 °C and -25 °C is permissible. For continuous operation at ambient temperatures below -25 °C (e.g. refrigeration applications), a fan version with special low-temperature bearings must be used.
Max. permissible ambient motor temp. (transp./ storage)	+80 °C
Min. permissible ambient motor temp. (transp./storage)	-40 °C
Mounting position	Shaft horizontal or rotor on bottom; rotor on top on request
Condensation drainage holes	Rotor-side
Operation mode	S1
Motor bearing	Ball bearing
Technical features	<ul style="list-style-type: none"> <li>- Output 10 VDC, max. 10 mA</li> <li>- Operation and alarm display</li> <li>- Alarm relay</li> <li>- Integrated PID controller</li> <li>- Output limit</li> <li>- Motor current limit</li> <li>- PFC, active</li> <li>- RS485 MODBUS RTU</li> <li>- Soft start</li> <li>- Control input 0-10 VDC / PWM</li> <li>- Control interface with SELV potential safely disconnected from the mains</li> <li>- Over-temperature protected electronics / motor</li> <li>- Line undervoltage / phase failure detection</li> </ul>
Touch current acc. IEC 60990 (measuring network Fig. 4, TN system)	<= 3.5 mA
Electrical connection	Terminal box
Motor protection	Thermal overload protector (TOP) wired internally
Cable exit	Variable
Protection class	I (if protective earth is connected by customer)
Product conforming to standard	EN 61800-5-1; CE
Approval	CSA C22.2 no. 77 + CAN/CSA-E60730-1; CCC; UL 1004-7 + 60730

# EC centrifugal fan - RadiPac

backward curved, single inlet

## Product drawing

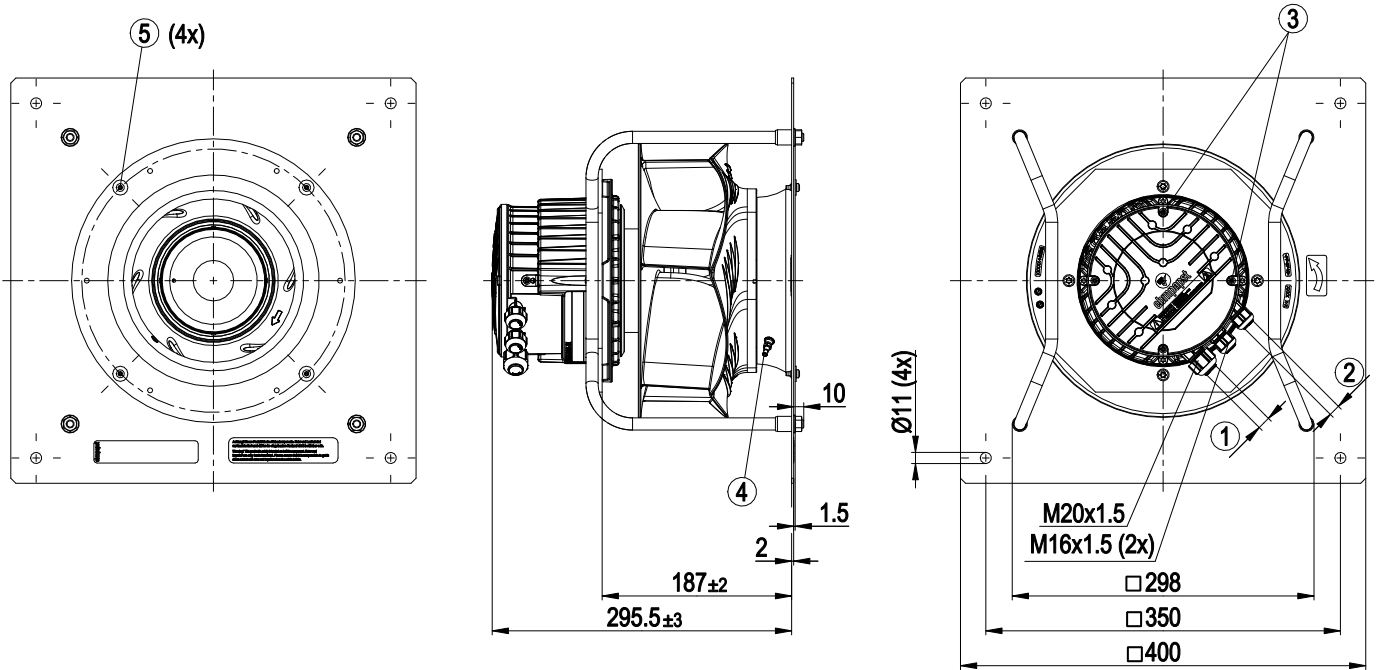

1	Cable diameter min. 8 mm, max. 12 mm, tightening torque 1.8±0.3 Nm (use the provided seal) Cable diameter min. 4 mm, max. 10 mm, tightening torque 1.8±0.3 Nm
2	Cable diameter min. 6 mm, max. 10 mm, tightening torque 1.8±0.3 Nm (use the provided seal) Cable diameter min. 4 mm, max. 7 mm, tightening torque 1.8±0.3 Nm
3	Tightening torque 1.5±0.2 Nm
4	Inlet nozzle with pressure tap (k-factor: 76)
5	Mounting for inlet nozzle and FlowGrid

## Connection screen

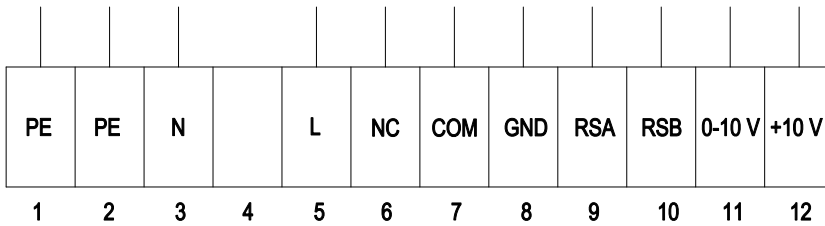

No.	Conn.	Designation	Function / assignment
1	PE	PE	Protective earth
2	PE	PE	Protective earth
3	N	N	Power supply, neutral conductor
4	-	-	not used
5	L	L	Power supply, phase
6	NC	NC	Status relay, floating status contact, break for failure, contact rating 250 VAC / 2 A (AC1) min. 10 mA, basic insulation on mains side and reinforced insulation on control interface side
7	COM	COM	Status relay, floating status contact, common connection, contact rating 250 VAC / 2 A (AC1) / min. 10 mA, basic insulation on mains side and reinforced insulation on control interface side
8	GND	GND	Signal ground for control interface, SELV
9	RSA	RSA	RS-485 interface for MODBUS, RSA; SELV
10	RSB	RSB	RS-485 interface for MODBUS, RSB; SELV
11	0-10 V	0-10 V	Analogue input (set value) SELV, 0-10 V, Ri=100kΩ, parametrisable curve
12	+10 V	+10 V	Fixed voltage output 10 VDC, SELV, +10 V ±3%, max. 10 mA, short-circuit-proof, power supply for external devices (e.g. potentiometer)

## Charts: Air flow 50 Hz

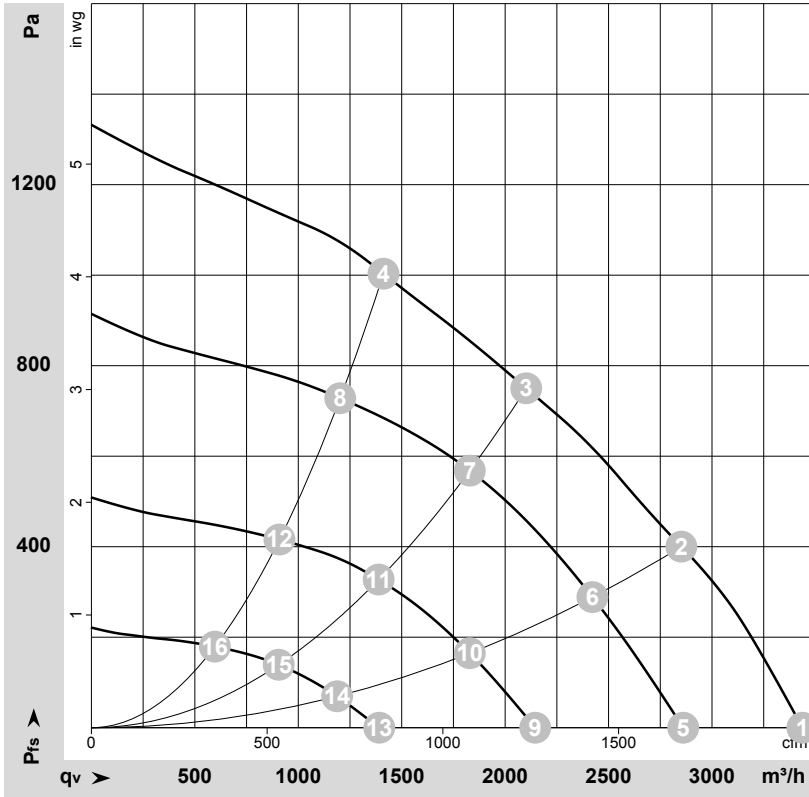

$\rho = 1.15 \text{ kg/m}^3 \pm 2 \%$

Measurement: LU-174661-1

Air performance measured as per ISO 5801 Installation category A. For detailed information on the measuring set-up, please contact ebmpapst. Suction-side noise levels: LwA measured as per ISO 13347 / LpA measured with 1m distance to fan axis. The values given are valid under the measuring conditions mentioned above and may vary according to the actual installation situation. With any deviation from the standard set-up, the specific values have to be checked and reviewed with the unit installed.

## Measured values

	U	f	n	P <sub>ed</sub>	I	LpA <sub>in</sub>	LwA <sub>in</sub>	q <sub>v</sub>	P <sub>fs</sub>	q <sub>v</sub>	P <sub>fs</sub>
	V	Hz	min <sup>-1</sup>	W	A	dB(A)	dB(A)	m <sup>3</sup> /h	Pa	cfm	in. wg
1	230	50	3645	627	2.74	80	87	3435	0	2025	0.00
2	230	50	3490	731	3.19	76	82	2850	400	1680	1.61
3	230	50	3450	750	3.30	73	78	2100	750	1235	3.01
4	230	50	3500	720	3.15	76	82	1410	1000	830	4.01
5	230	50	3035	369	1.64	76	83	2860	0	1685	0.00
6	230	50	2975	454	2.01	73	78	2420	289	1425	1.16
7	230	50	2960	477	2.10	71	76	1830	568	1075	2.28
8	230	50	2980	449	1.99	72	77	1205	728	710	2.92
9	230	50	2290	172	0.79	69	76	2145	0	1260	0.00
10	230	50	2260	210	0.95	66	72	1830	166	1075	0.67
11	230	50	2250	225	1.01	64	69	1390	329	820	1.32
12	230	50	2265	211	0.96	65	71	910	416	535	1.67
13	230	50	1510	64	0.37	58	65	1390	0	820	0.00
14	230	50	1490	75	0.41	55	63	1190	70	700	0.28
15	230	50	1485	79	0.42	52	59	905	140	535	0.56
16	230	50	1490	75	0.41	53	59	595	179	350	0.72

U = Supply voltage · f = Frequency · n = Speed (rpm) · P<sub>ed</sub> = Power input · I = Current draw · LpA<sub>in</sub> = Sound pressure level inlet side · LwA<sub>in</sub> = Sound power level inlet side · q<sub>v</sub> = Air flow  
P<sub>fs</sub> = Pressure increase

