

Test terminal strip - UTWE 6-2/C19 - 3069417

Please be informed that the data shown in this PDF Document is generated from our Online Catalog. Please find the complete data in the user's documentation. Our General Terms of Use for Downloads are valid (<http://phoenixcontact.com/download>)



Test terminal strip, VDE coded type C19, A detailed circuit diagram can be found under Miscellaneous Downloads, nom. voltage: 400 V AC/DC, connection method: Screw connection, number of connections: 38, number of positions: 19, cross section: 0.2 mm² - 10 mm², AWG: 24 - 8, width: 188.6 mm, height: 56.5 mm, color: gray, mounting type: Wall mounting

Your advantages

- ✓ Space saving, thanks to compact, modular test terminal strips
- ✓ Cost-effective, thanks to the tailored, modular design and use of standardized CLIPLINE complete accessories
- ✓ Maximum safety with leading and automatic transformer short circuit
- ✓ The integrated, robust switch contact is designed for the most stringent demands, and the use of high-quality materials ensures the transmission of signal currents, even after multiple actuations



Key Commercial Data

Packing unit	1 pc
GTIN	
GTIN	4046356943123
Weight per Piece (excluding packing)	99.990 g
Custom tariff number	85369010
Country of origin	Poland
Note	Made to Order (non-returnable)

Technical data

General

Note	A detailed circuit diagram can be found under Miscellaneous Downloads
Number of positions	19
Number of levels	1
Number of connections	38
Potentials	19
Nominal cross section	6 mm ²
Color	gray
Insulating material	PA

Test terminal strip - UTWE 6-2/C19 - 3069417

Technical data

General

Flammability rating according to UL 94	V0
Rated surge voltage	4 kV
Test surge voltage	5 kV
Overvoltage category	III
Insulating material group	I
Maximum power dissipation for nominal condition	1.31 W
Ambient temperature (operation)	-60 ... 85 (°)
Ambient temperature (storage/transport)	-25 ... 55
Ambient temperature (assembly)	-5 ... 70
Ambient temperature (actuation)	-5 ... 70
Maximum load current	30 A (with 10 mm ² conductor cross section)
Nominal voltage U _N	400 V AC/DC
Open side panel	No
Terminal block mounting	0.8 Nm ... 1 Nm
Result of surge voltage test	Test passed
Surge voltage test setpoint	4.8 kV
Result of power-frequency withstand voltage test	Test passed
Power frequency withstand voltage setpoint	1.89 kV
Result of the test for mechanical stability of terminal points (5 x conductor connection)	Test passed
Result of bending test	Test passed
Bending test rotation speed	10 rpm
Bending test turns	135
Bending test conductor cross section/weight	0.2 mm ² / 0.2 kg
	6 mm ² / 1.4 kg
	10 mm ² / 2 kg
Tensile test result	Test passed
Conductor cross section tensile test	0.2 mm ²
Tractive force setpoint	10 N
Conductor cross section tensile test	6 mm ²
Tractive force setpoint	80 N
Conductor cross section tensile test	10 mm ²
Tractive force setpoint	90 N
Result of tight fit on support	Test passed
Setpoint	5 N
Result of voltage-drop test	Test passed
Requirements, voltage drop	≤ 4.8 mV
Result of temperature-rise test	Test passed
Short circuit stability result	Test passed
Conductor cross section short circuit testing	4 mm ²
Short-time current	300 A

Test terminal strip - UTWE 6-2/C19 - 3069417

Technical data

General

Conductor cross section short circuit testing	4 mm ²
Short-time current	500 A
Result of thermal test	Test passed
Ageing test for screwless modular terminal block temperature cycles	192
Proof of thermal characteristics (needle flame) effective duration	30 s
Result of aging test	Test passed
Oscillation, broadband noise test result	Test passed
Test specification, oscillation, broadband noise	DIN EN 50155 (VDE 0115-200):2008-03
Test spectrum	Service life test category 2, bogie-mounted
Test frequency	f ₁ = 5 Hz to f ₂ = 250 Hz
ASD level	6.12 (m/s ²) ² /Hz
Acceleration	3.12 g
Test duration per axis	5 h
Test directions	X-, Y- and Z-axis
Shock test result	Test passed
Test specification, shock test	DIN EN 50155 (VDE 0115-200):2008-03
Shock form	Half-sine
Acceleration	30g
Shock duration	18 ms
Number of shocks per direction	3
Test directions	X-, Y- and Z-axis (pos. and neg.)
Relative insulation material temperature index (Elec., UL 746 B)	130 °C
Temperature index of insulation material (DIN EN 60216-1 (VDE 0304-21))	125 °C
Static insulating material application in cold	-60 °C
Behavior in fire for rail vehicles (DIN 5510-2)	Test passed
Flame test method (DIN EN 60695-11-10)	V0
Oxygen index (DIN EN ISO 4589-2)	>32 %
NF F16-101, NF F10-102 Class I	2
NF F16-101, NF F10-102 Class F	2
Surface flammability NFPA 130 (ASTM E 162)	passed
Specific optical density of smoke NFPA 130 (ASTM E 662)	passed
Smoke gas toxicity NFPA 130 (SMP 800C)	passed
Calorimetric heat release NFPA 130 (ASTM E 1354)	27,5 MJ/kg
Fire protection for rail vehicles (DIN EN 45545-2) R22	HL 1 - HL 3
Fire protection for rail vehicles (DIN EN 45545-2) R23	HL 1 - HL 3
Fire protection for rail vehicles (DIN EN 45545-2) R24	HL 1 - HL 3
Fire protection for rail vehicles (DIN EN 45545-2) R26	HL 1 - HL 3

Dimensions

Width	188.6 mm
-------	----------

Test terminal strip - UTWE 6-2/C19 - 3069417

Technical data

Dimensions

Length	100 mm
Height	56.5 mm
Plate thickness	1 mm ... 4 mm
Pitch	8.2 mm

Connection data

Connection	1 level
Connection method	Screw connection
Screw thread	M4
Stripping length	12 mm
Tightening torque, min	1.5 Nm
Tightening torque max	1.8 Nm
Connection in acc. with standard	IEC 60947-7-1
Conductor cross section solid min.	0.2 mm ²
Conductor cross section solid max.	10 mm ²
Conductor cross section AWG min.	24
Conductor cross section AWG max.	8
Conductor cross section flexible min.	0.2 mm ²
Conductor cross section flexible max.	10 mm ²
Min. AWG conductor cross section, flexible	24
Max. AWG conductor cross section, flexible	8
Conductor cross section flexible, with ferrule without plastic sleeve min.	0.25 mm ²
Conductor cross section flexible, with ferrule without plastic sleeve max.	6 mm ²
Conductor cross section flexible, with ferrule with plastic sleeve min.	0.25 mm ²
Conductor cross section flexible, with ferrule with plastic sleeve max.	6 mm ²
2 conductors with same cross section, solid min.	0.2 mm ²
2 conductors with same cross section, solid max.	2.5 mm ²
2 conductors with same cross section, stranded min.	0.2 mm ²
2 conductors with same cross section, stranded max.	2.5 mm ²
Two conductors with the same cross section, flexible, with TWIN ferrules, with plastic sleeve, minimum	0.5 mm ²
Two conductors with the same cross section, flexible, with TWIN ferrules, with plastic sleeve, maximum	2.5 mm ²
Two conductors with the same cross section stranded, with ferrule and without plastic sleeve, minimum	0.25 mm ²
Two conductors with the same cross section stranded, with ferrule and without plastic sleeve, maximum	1.5 mm ²
Internal cylindrical gage	A5

Mounting

Mounting type	Wall mounting
Plate thickness	1 mm ... 4 mm
Min. tightening torque of the mounting screw:	0.8 Nm

Test terminal strip - UTWE 6-2/C19 - 3069417

Technical data

Mounting

Max. tightening torque of the mounting screw:	1 Nm
---	------

Standards and Regulations

Connection in acc. with standard	IEC 60947-7-1
Flammability rating according to UL 94	V0

Environmental Product Compliance

	Lead 7439-92-1
--	----------------

Drawings

Dimensional drawing

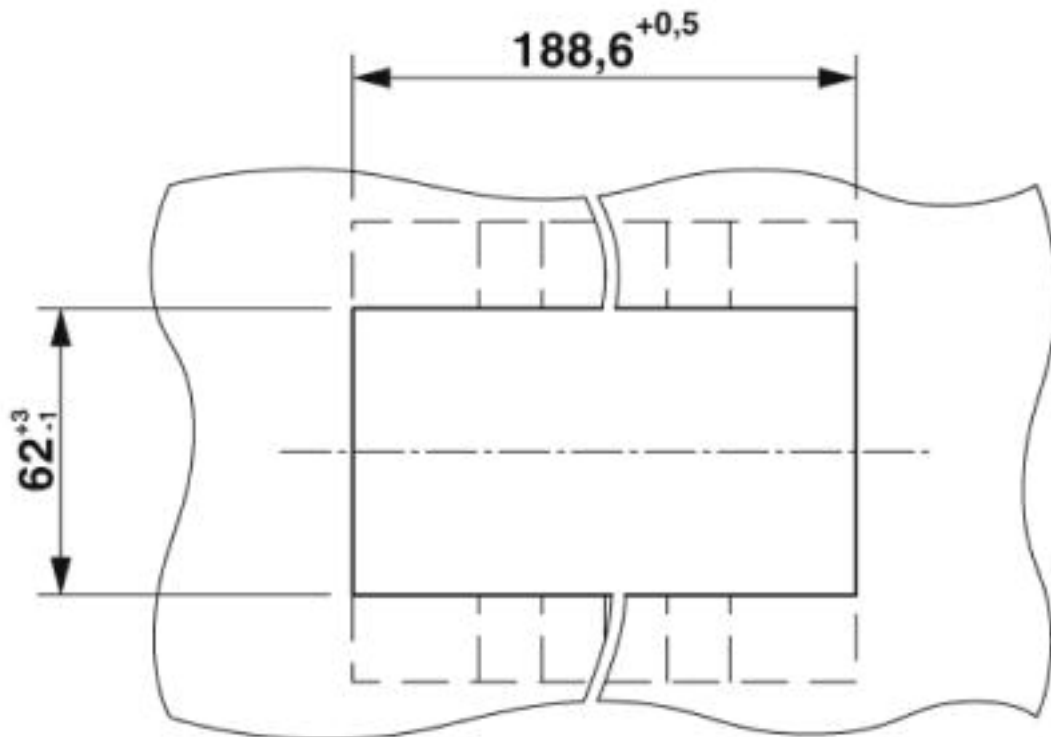

Circuit diagram



Test terminal strip - UTWE 6-2/C19 - 3069417

Dimensional drawing

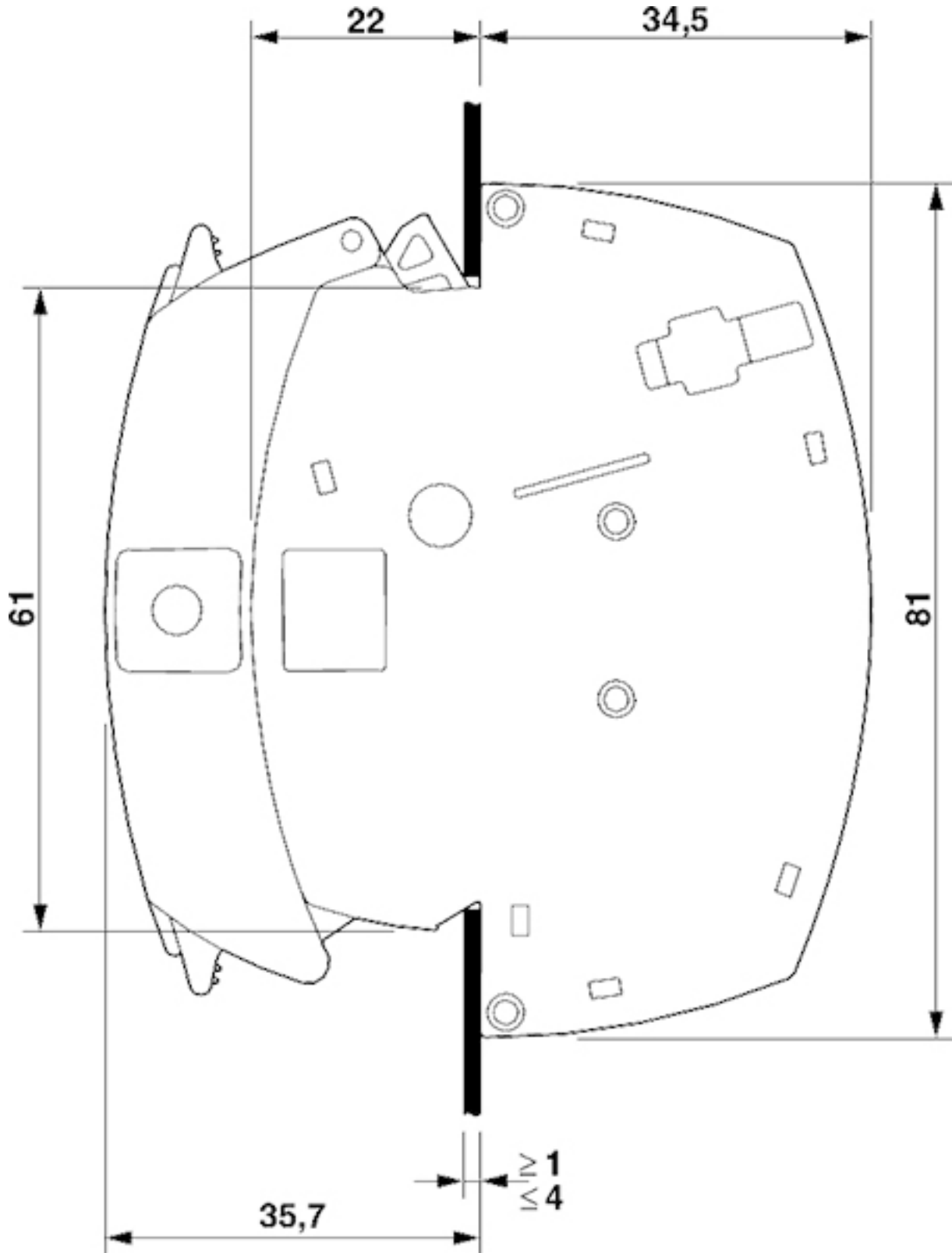

Test terminal strip - UTWE 6-2/C19 - 3069417

Classifications

eCl@ss

eCl@ss 4.0	27141100
eCl@ss 4.1	27141100
eCl@ss 5.0	27141100
eCl@ss 5.1	27141100
eCl@ss 6.0	27141100
eCl@ss 7.0	27141126
eCl@ss 8.0	27141126
eCl@ss 9.0	27141126

ETIM

ETIM 3.0	EC000901
ETIM 4.0	EC000897
ETIM 5.0	EC000902
ETIM 6.0	EC000902
ETIM 7.0	EC000902

UNSPSC

UNSPSC 6.01	30211811
UNSPSC 7.0901	39121410
UNSPSC 11	39121410
UNSPSC 12.01	39121410
UNSPSC 13.2	39121410
UNSPSC 18.0	39121410
UNSPSC 19.0	39121410
UNSPSC 20.0	39121410
UNSPSC 21.0	39121410

Approvals

Approvals

Approvals

CSA / UL Recognized / cUL Recognized / EAC / cULus Recognized

Ex Approvals

Approval details

Test terminal strip - UTWE 6-2/C19 - 3069417

Approvals

CSA		http://www.csagroup.org/services-industries/product-listing/	013631
		D	
Nominal voltage UN	300 V		
Nominal current IN	10 A		
mm ² /AWG/kcmil	24-8		

UL Recognized		http://database.ul.com/cgi-bin/XYV/template/LISEXT/1FRAME/index.htm	FILE E 60425
		D	
Nominal voltage UN	300 V		
Nominal current IN	10 A		
mm ² /AWG/kcmil	24-8		

cUL Recognized		http://database.ul.com/cgi-bin/XYV/template/LISEXT/1FRAME/index.htm	FILE E 60425
		D	
Nominal voltage UN	300 V		
Nominal current IN	10 A		
mm ² /AWG/kcmil	24-8		

EAC		RU C- DE.BL08.B.00682
-----	--	--------------------------

cULus Recognized	
------------------	--

Accessories

Accessories

Blind plug

Dummy plug - FBP-2/C19 - 3069504



Dummy plug, VDE coded type C19, pitch: 8.2 mm, length: 81 mm, width: 187.5 mm, number of positions: 19, color: gray

Test terminal strip - UTWE 6-2/C19 - 3069417

Accessories

Cover profile

Cover profile - AP RSC-T - 3059139



Cover profile, for covering terminal strips, directly snapped onto RBO... and RSC... test disconnect terminal blocks. Length supplied: 1 m

Cover profile carrier

Cover profile carrier - APH-UTWE 6-2 - 3069057



Cover profile carrier, width: 8 mm, height: 56.6 mm, material: PA, length: 80.9 mm, color: gray

Labeled terminal marker

Zack marker strip - ZB 8 CUS - 0825011



Zack marker strip, can be ordered: Strip, white, labeled according to customer specifications, mounting type: snap into tall marker groove, for terminal block width: 8.2 mm, lettering field size: 10.5 x 8.15 mm, Number of individual labels: 10

Marker for terminal blocks - UC-TM 8 CUS - 0824597



Marker for terminal blocks, can be ordered: by sheet, white, labeled according to customer specifications, mounting type: snap into tall marker groove, for terminal block width: 8.2 mm, lettering field size: 7.6 x 10.5 mm, Number of individual labels: 56

Marker for terminal blocks - UCT-TM 8 CUS - 0829616



Marker for terminal blocks, can be ordered: by sheet, white, labeled according to customer specifications, mounting type: snap into tall marker groove, for terminal block width: 8.2 mm, lettering field size: 7.6 x 10.5 mm, Number of individual labels: 42

Test terminal strip - UTWE 6-2/C19 - 3069417

Accessories

Zack marker strip - ZB 8,LGS:FORTL.ZAHLEN - 1052015



Zack marker strip, Strip, white, labeled, can be labeled with: CMS-P1-PLOTTER, printed horizontally: consecutive numbers 1 ... 10, 11 ... 20, etc. up to 91 ... 100, mounting type: snap into tall marker groove, for terminal block width: 8.2 mm, lettering field size: 10.5 x 8.15 mm, Number of individual labels: 10

Zack marker strip - ZB 8,QR:FORTL.ZAHLEN - 1052028



Zack marker strip, Strip, white, labeled, can be labeled with: CMS-P1-PLOTTER, Printed vertically: consecutive numbers 1 ... 10, 11 ... 20, etc. up to 91 ... 100, mounting type: snap into tall marker groove, for terminal block width: 8.2 mm, lettering field size: 10.5 x 8.15 mm, Number of individual labels: 10

Marker for terminal blocks - ZB 8,LGS:L1-N,PE - 1052413



Marker for terminal blocks, Strip, white, labeled, can be labeled with: CMS-P1-PLOTTER, Horizontal: L1, L2, L3, N, PE, L1, L2, L3, N, PE, mounting type: snap into tall marker groove, for terminal block width: 8.2 mm, lettering field size: 10.5 x 8.15 mm, Number of individual labels: 10

Screwdriver tools

Screwdriver - SF-SL 0,8X4,0-100 - 1212551



Screwdriver, bladed (lasered), size: 0.8 x 4.0 x 100 mm, 2-component grip, with non-slip grip

Screwdriver - SF-SL 0,8X4,0-100 S-VDE - 1212588



Actuation tool, for ST terminal blocks, VDE insulated, with slimmer insulation integrated in the blade, also suitable for use as a bladed screwdriver, size: 0.8 x 4.0 x 100 mm, 2-component grip, with non-slip grip

Terminal marking

Test terminal strip - UTWE 6-2/C19 - 3069417

Accessories

Zack marker strip - ZB 8:UNBEDRUCKT - 1052002



Zack marker strip, Strip, white, unlabeled, can be labeled with: CMS-P1-PLOTTER, PLOTMARK, mounting type: snap into tall marker groove, for terminal block width: 8.2 mm, lettering field size: 10.5 x 8.15 mm, Number of individual labels: 10

Marker for terminal blocks - UC-TM 8 - 0818072



Marker for terminal blocks, Sheet, white, unlabeled, can be labeled with: BLUEMARK ID COLOR, BLUEMARK ID, BLUEMARK CLED, PLOTMARK, CMS-P1-PLOTTER, mounting type: snap into tall marker groove, for terminal block width: 8.2 mm, lettering field size: 7.6 x 10.5 mm, Number of individual labels: 56

Marker for terminal blocks - UCT-TM 8 - 0828740



Marker for terminal blocks, Sheet, white, unlabeled, can be labeled with: TOPMARK NEO, TOPMARK LASER, BLUEMARK ID COLOR, BLUEMARK ID, BLUEMARK CLED, THERMOMARK PRIME, THERMOMARK CARD 2.0, THERMOMARK CARD, mounting type: snap into tall marker groove, for terminal block width: 8.2 mm, lettering field size: 7.6 x 10.5 mm, Number of individual labels: 42

Marker for terminal blocks - TMT (EX9,5)R - 0828295



Marker for terminal blocks, Roll, white, unlabeled, can be labeled with: THERMOMARK ROLL 2.0, THERMOMARK ROLL, THERMOMARK ROLL X1, THERMOMARK ROLLMASTER 300/600, THERMOMARK X1.2, mounting type: snap into universal marker groove, snap into tall marker groove, for terminal block width: 50000 mm, lettering field size: 9.5 x 50000 mm, Number of individual labels: 1

Marker for terminal blocks - US-TM 100 - 0829255



Marker for terminal blocks, Card, white, unlabeled, can be labeled with: BLUEMARK ID COLOR, BLUEMARK ID, THERMOMARK PRIME, THERMOMARK CARD 2.0, THERMOMARK CARD, mounting type: snap into universal marker groove, lettering field size: 104 x 9.8 mm, Number of individual labels: 13

Test plug terminal block

Test terminal strip - UTWE 6-2/C19 - 3069417

Accessories

Test plug - FTPR-2/C19 - 3069491



Test plug, with twist grip, VDE coded type C19, A detailed circuit diagram can be found under Miscellaneous Downloads, nom. voltage: 400 V AC/DC, nominal current: 24 A, number of positions: 19, width: 187.5 mm, color: gray

Test plug - FTP-2/C19 - 3069478



Test plug, VDE coded type C19, number of positions: 19, width: 187.5 mm, color: gray

Test plug - FTP-2/1 SERVICE - 3069469



Test plug, number of positions: 1, width: 9 mm, color: red

Test socket

Test adapter - PAI-4-N GY - 3032871



4 mm test adapter, for terminal blocks with 5.2 mm, 6.2 mm and 8.2 mm pitch

Test adapter - PAI-4-FIX BU - 3032729



Test adapter, for 4 mm test plug and terminal blocks with 8.2 mm pitch, color: blue

Test terminal strip - UTWE 6-2/C19 - 3069417

Accessories

Test adapter - PAI-4-FIX OG - 3034455



4 mm test adapter, for terminal blocks with 8.2 mm pitch

Test adapter - PAI-4-FIX YE - 3032745



Test adapter, for 4 mm test plug and terminal blocks with 8.2 mm pitch, color: yellow

Test adapter - PAI-4-FIX RD - 3032732



Test adapter, for 4 mm test plug and terminal blocks with 8.2 mm pitch, color: red

Test adapter - PAI-4-FIX GN - 3032758



Test adapter, for 4 mm test plug and terminal blocks with 8.2 mm pitch, color: green

Test adapter - PAI-4-FIX BK - 3032774



Test adapter, for 4 mm test plug and terminal blocks with 8.2 mm pitch, color: black

Test terminal strip - UTWE 6-2/C19 - 3069417

Accessories

Test adapter - PAI-4-FIX GY - 3032790



Test adapter, for 4 mm test plug and terminal blocks with 8.2 mm pitch, color: gray

Test adapter - PAI-4-FIX VT - 3032761



Test adapter, for 4 mm test plug and terminal blocks with 4.2 mm ... 8.2 mm pitch, color: violet

Test adapter - PAI-4-FIX BN - 3032787



Test adapter, for 4 mm test plug and terminal blocks with 8.2 mm pitch, color: brown

Test adapter - PAI-4-FIX WH - 3032797



4 mm test adapter, for terminal blocks with 8.2 mm pitch

Test adapter - PAIS-4-FIX GY - 3032791



Test adapter, for 4 mm test plug and terminal blocks with 5.2 mm, 6.2 mm, and 8.2 mm pitch, color: gray

Test terminal strip - UTWE 6-2/C19 - 3069417

Accessories

Test adapter - PAIS-4-FIX BK - 3032792



Test adapter, for 4 mm test plug and terminal blocks with 5.2 mm, 6.2 mm, and 8.2 mm pitch, color: black

Test adapter - PAIS-4-FIX RD - 3032793



Test adapter, for 4 mm test plug and terminal blocks with 5.2 mm, 6.2 mm, and 8.2 mm pitch, color: red

Test adapter - PAIS-4-FIX BU - 3032798



Test adapter, for 4 mm test plug and terminal blocks with 5.2 mm, 6.2 mm, and 8.2 mm pitch, color: blue

Test adapter - PAIS-4-FIX YE - 3032799



Test adapter, for 4 mm test plug and terminal blocks with 5.2 mm, 6.2 mm, and 8.2 mm pitch, color: yellow

Test adapter - PAIS-4-FIX GN - 3032801



Test adapter, for 4 mm test plug and terminal blocks with 5.2 mm, 6.2 mm, and 8.2 mm pitch, color: green

Test terminal strip - UTWE 6-2/C19 - 3069417

Accessories

Test adapter - PAIS-4-FIX VT - 3032802



Test adapter, for 4 mm test plug and terminal blocks with 5.2 mm, 6.2 mm, and 8.2 mm pitch, color: violet

Phoenix Contact 2020 © - all rights reserved
<http://www.phoenixcontact.com>