

# Temperature measuring transducer - MINI MCR-SL-PT100-LP-NC - 2810308

Please be informed that the data shown in this PDF Document is generated from our Online Catalog. Please find the complete data in the user's documentation. Our General Terms of Use for Downloads are valid (<http://phoenixcontact.com/download>)



Configurable loop-powered temperature transducer for Pt 100 temperature sensors, configured via DIP switches, with screw connection, not pre-configured

## Product Features

- ✓ 2, 3 or 4-wire Pt 100 sensors
- ✓ Highly-compact loop-powered temperature transducer for electrical isolation, conversion, amplification, and filtering of Pt 100 signals to create standard signals
- ✓ Does not require additional auxiliary voltage
- ✓ Error indication via diagnostic LED and analog signal
- ✓ 2-way isolation
- ✓ Input signals can be configured via DIP switches
- ✓ Supplied by an output loop
- ✓ Temperature measuring range of -150°C to +300°C



## Key commercial data

Packing unit	1 pc
Weight per Piece (excluding packing)	80.0 GRM
Custom tariff number	85437090
Country of origin	Germany

## Technical data

### Note

Utilization restriction	EMC: class A product, see manufacturer's declaration in the download area
-------------------------	---

# Temperature measuring transducer - MINI MCR-SL-PT100-LP-NC - 2810308

## Technical data

### Dimensions

Width	6.2 mm
Height	93.1 mm
Depth	102.5 mm

### Ambient conditions

Ambient temperature (operation)	-20 °C ... 65 °C
Ambient temperature (storage/transport)	-40 °C ... 85 °C
Degree of protection	IP20

### Input data

Configurable/programmable	Yes, unconfigured
Sensor types (RTD) that can be used	Pt 100 (IEC 60751/EN 60751)
Sensor input current	1 mA (constant)
Temperature measuring range	-150 °C ... 300 °C (can be set via DIP switches)
Connection method	2, 3, 4-wire

### Output data

Configurable/programmable	Yes, unconfigured
Current output signal	4 mA ... 20 mA
	20 mA ... 4 mA
Max. output current	23 mA (output limit)
Load/output load current output	( $U_{\text{supply}} - 12 \text{ V}$ ) / 22 mA

### Power supply

Designation	Loop-powered
Supply voltage range	12 V DC ... 30 V DC
Max. current consumption	< 3.5 mA (without signal current)
Power consumption	< 42 mW

### Connection data

Connection method	Screw connection
Conductor cross section solid min.	0.2 mm <sup>2</sup>
Conductor cross section solid max.	2.5 mm <sup>2</sup>
Conductor cross section AWG/kcmil min.	26
Conductor cross section AWG/kcmil max.	12
Conductor cross section stranded min.	0.2 mm <sup>2</sup>
Conductor cross section stranded max.	2.5 mm <sup>2</sup>
Stripping length	12 mm
Screw thread	M3

# Temperature measuring transducer - MINI MCR-SL-PT100-LP-NC - 2810308

## Technical data

### General

Maximum temperature coefficient	< 0.02 %/K
Linearity error	< 0.05 % (for full measuring range)
Electrical isolation	Basic insulation according to EN 61010
Surge voltage category	II
Pollution degree	2
Rated insulation voltage	50 V AC/DC
Test voltage, input/output/supply	1.5 kV (50 Hz, 1 min.)
Electromagnetic compatibility	Conformance with EMC Directive 2004/108/EC
Noise emission	EN 61000-6-4
Noise immunity	EN 61000-6-2 When being exposed to interference, there may be minimal deviations.
Color	green
Housing material	PBT
Mounting position	any
Conformance	CE-compliant
ATEX	# II 3 G Ex nA IIC T4 Gc X
UL, USA / Canada	UL 508 Recognized
	Class I, Div. 2, Groups A, B, C, D T5 applied for

### EMC data

Designation	Electromagnetic RF field
Standards/regulations	EN 61000-4-3
Typical deviation from the measuring range final value	5 %
Designation	Fast transients (burst)
Standards/regulations	EN 61000-4-4
Typical deviation from the measuring range final value	5 %
Designation	Conducted interferences
Standards/regulations	EN 61000-4-6
Typical deviation from the measuring range final value	5 %

## Classifications

### eCl@ss

eCl@ss 4.0	27200206
eCl@ss 4.1	27200206
eCl@ss 5.0	27200206
eCl@ss 5.1	27200206

# Temperature measuring transducer - MINI MCR-SL-PT100-LP-NC - 2810308

## Classifications

### eCl@ss

eCl@ss 6.0	27200206
eCl@ss 7.0	27200206
eCl@ss 8.0	27200206

### ETIM

ETIM 2.0	EC001446
ETIM 3.0	EC001446
ETIM 4.0	EC001446
ETIM 5.0	EC001446

### UNSPSC

UNSPSC 6.01	30211506
UNSPSC 7.0901	39121008
UNSPSC 11	39121008
UNSPSC 12.01	39121008
UNSPSC 13.2	39121008

## Approvals

### Approvals

---

#### Approvals

UL Recognized / cUL Recognized / cULus Recognized

---

#### Ex Approvals

#### ATEX

---

#### Approvals submitted

---

### Approval details

UL Recognized 
---

# Temperature measuring transducer - MINI MCR-SL-PT100-LP-NC - 2810308

## Approvals

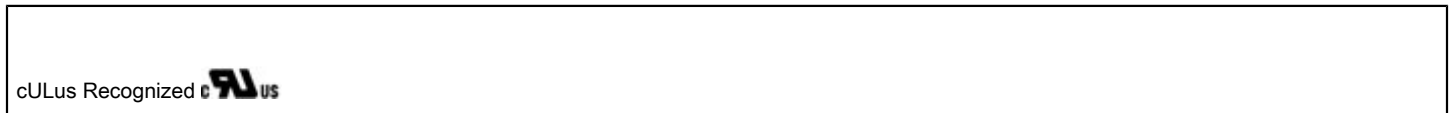

## Drawings

Application drawing

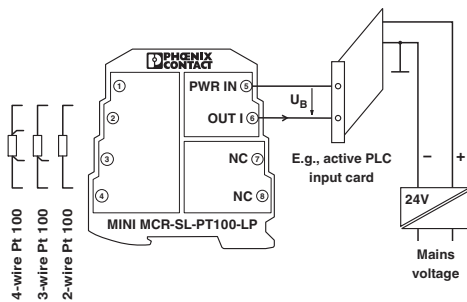

Block diagram

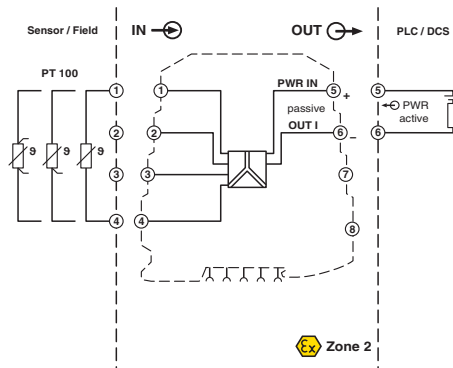

Dimensioned drawing

